

QT-Brightek PLCC2 Series

PLCC2 White LED

Part No.: QBLP670-IW-XX

XX = WW/NW/CW

Table of Contents:

Introduction	3
Electrical / Optical Characteristic (T=25 °C)	4
Absolute Maximum Rating	4
Correlated Color Temperature Chart	6
Characteristic Curves.....	7
Solder Profile & Footprint.....	8
Packing	9
Labeling	10
Ordering Information	10
Disclaimer	11

Introduction

Feature:

- Package in tape and reel
- Ultra bright reflector type PLCC2 LED
- InGaN technology for White
- 120 degree viewing angle

Description:

These ultra bright reflector type PLCC2 LEDs have a height profile of 1.90mm. With a combination of high brightness output and robust package, these LEDs are ideal for architecture lighting, status indication, and industrial equipment lighting applications.

Application:

- Status indication
- Industrial equipment backlighting
- Architecture lighting

Certification & Compliance:

- TS16949
- ISO9001
- RoHS Compliant



Dimension:

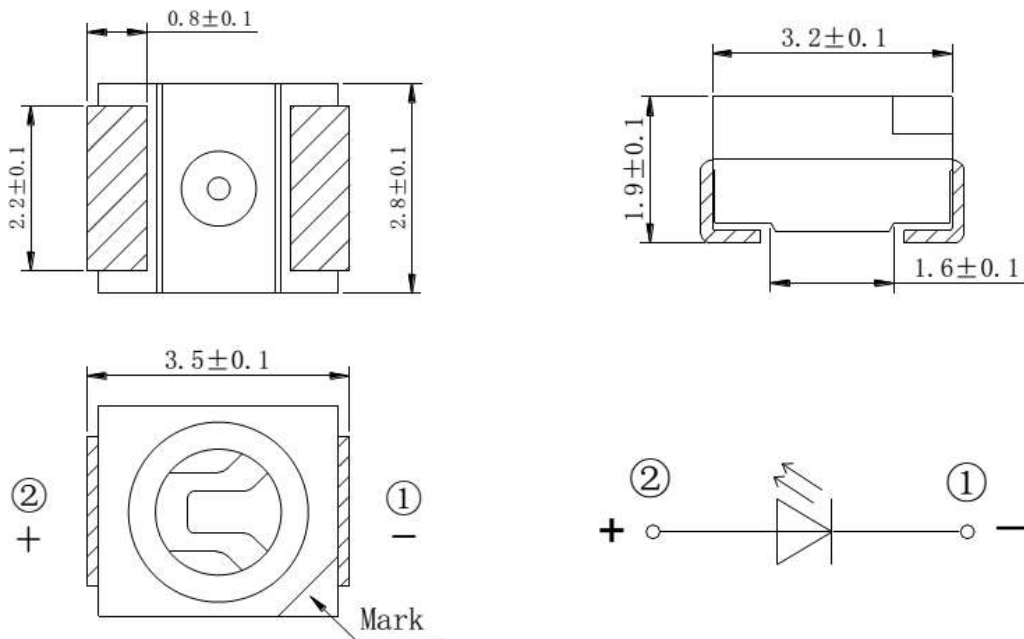

Units: mm / tolerance = +/-0.1mm

Electrical / Optical Characteristic (T=25 °C)

Product	Color	I _F (mA)	V _F (V)		CCT(K)			I _V (mcd)	
			Typ.	Max.	Min.	Typ.	Max.	Min.	Typ.
QBLP670-IW-WW	Warm White	20	3.2	3.4	2760	3000	3260	2100	2400
QBLP670-IW-NW	Natural White	20	3.2	3.4	3640	4000	4240	2200	2600
QBLP670-IW-CW	Cool White	20	3.2	3.4	5300	6020	7050	2200	2600

Absolute Maximum Rating

Material	P _d (mW)	I _F (mA)	I _{FP} (mA)*	V _R (V)	T _{OP} (°C)	T _{ST} (°C)	T _{SO L} (°C)**
InGaN	100	35	100	5	-40 to +85	-40 to +100	260

*Duty 1/10 @ 1KHz

** IR Reflow for no more than 10 sec @ 260 °C

Forward Voltage V_F @ I_F=20mA

Bin	Min.	Max.	Unit
H	2.8	3.0	V
J	3.0	3.2	
K	3.2	3.4	

Luminous Intensity I_V for Warm White (WW) @ I_F=20mA

Bin	Min.	Max.	Unit
L1	2100	2640	mcd
L2	2640	3168	
L3	3168	3801	

Luminous Intensity I_V for Natural White (NW) @ I_F=20mA

Bin	Min.	Max.	Unit
L1	2200	2640	mcd
L2	2640	3168	
L3	3168	3801	

Luminous Intensity I_V for Cool White (CW) @ I_F=20mA

Bin	Min.	Max.	Unit
L1	2200	2640	mcd
L2	2640	3168	
L3	3168	3801	

Note:

Tolerance of measurement of forward voltage: ±0.1V

Tolerance of measurement of luminous intensity: ±15%

Correlated Color Temperature (CCT) @ I_F=20mA

Bin	Min.	Max.	Unit
RN	2760	3260	K
RL	3640	4240	
RM	5300	6020	
RR	6020	7050	

Correlated Color Temperature Chart

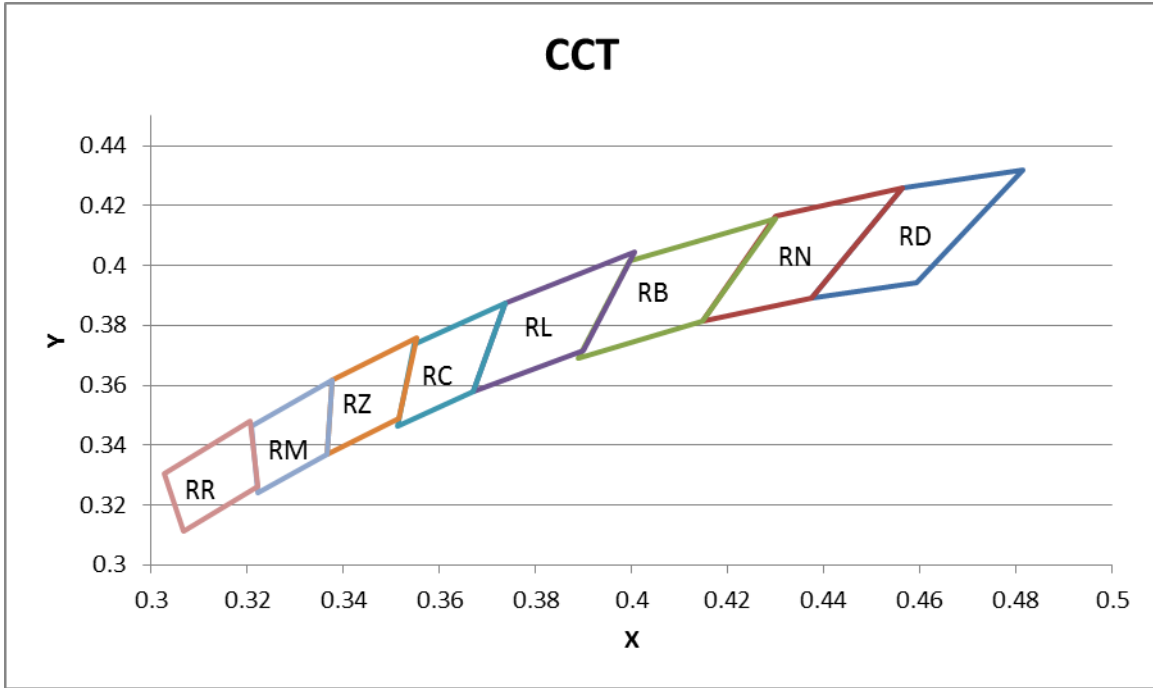

Color Ranks @ I _F =20mA							
RD		RN		RB		RL	
0.4813	0.4319	0.4562	0.426	0.4299	0.4156	0.4006	0.4044
0.4562	0.426	0.4299	0.4165	0.3996	0.4015	0.3736	0.3874
0.4373	0.3893	0.4147	0.3814	0.3889	0.369	0.367	0.3578
0.4593	0.3944	0.4373	0.3893	0.4147	0.3814	0.3898	0.3716
0.4813	0.4319	0.4562	0.426	0.4299	0.4156	0.4006	0.4044
RC		RZ		RM		RR	
0.3736	0.3874	0.3551	0.376	0.3376	0.3616	0.3205	0.3481
0.3548	0.3736	0.3376	0.3616	0.3207	0.3462	0.3028	0.3304
0.3512	0.3465	0.3366	0.3369	0.3222	0.3243	0.3068	0.3113
0.367	0.3578	0.3515	0.3487	0.3366	0.3369	0.3221	0.3261
0.3736	0.3874	0.3551	0.376	0.3376	0.3616	0.3205	0.3481

Note:
Tolerance of measurement of color coordinates: ±0.01

Characteristic Curves

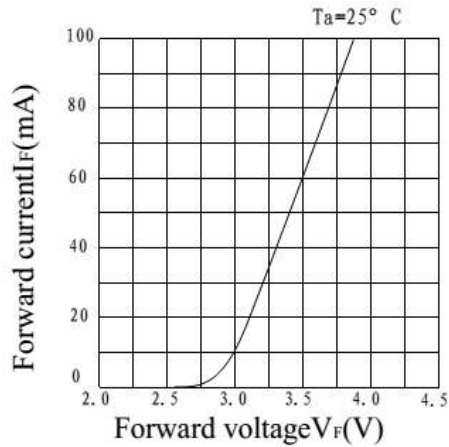

a) FORWARD CURRENT VS. FORWARD VOLTAGE

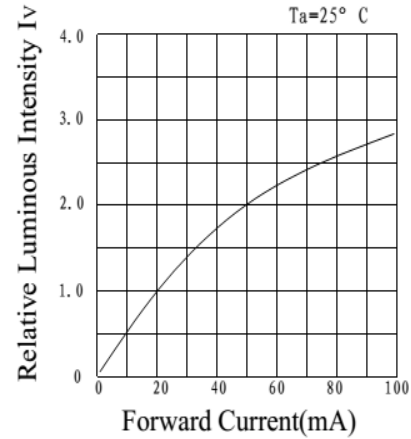

b) RELATIVE LUMINOUS INTENSITY VS. FORWARD CURRENT

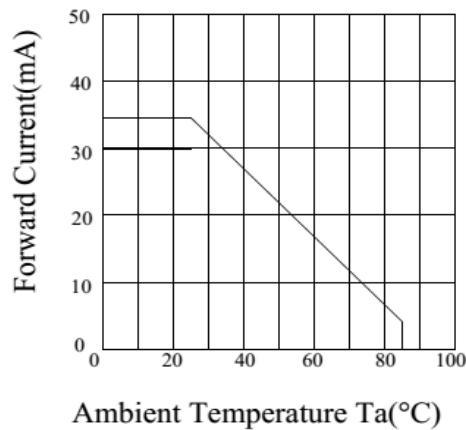

c) FORWARD CURRENT VS. AMBIENT TEMPERATURE

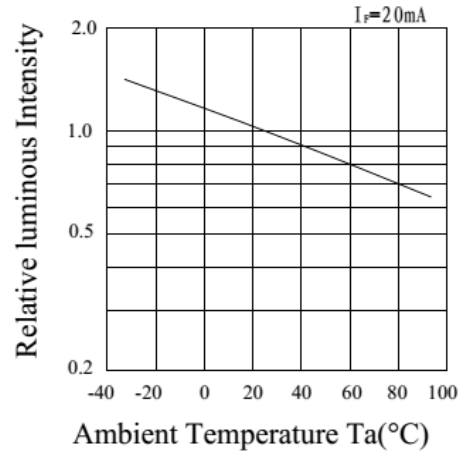

d) RELATIVE INTENSITY VS. AMBIENT TEMPERATURE

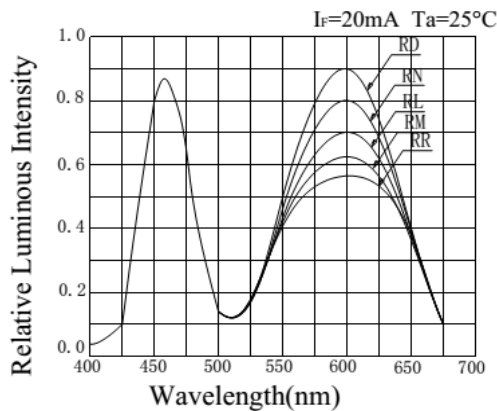

e) RELATIVE INTENSITY VS. WAVELENGTH

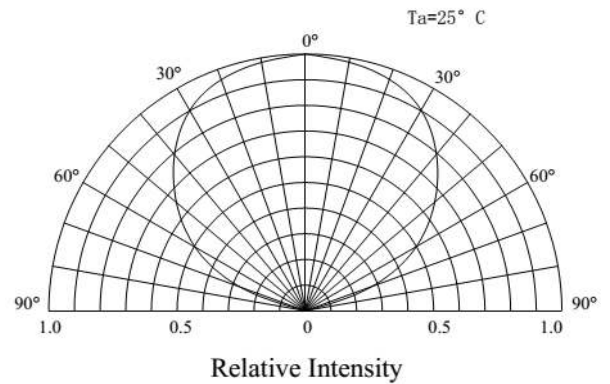

f) RADIATION PATTERN

Solder Profile & Footprint

- Recommended tin solder specifications: melting temperature in the range of 178~192 °C
- The recommended reflow soldering profile is as follows (temperatures indicated are as measured on the surface of the LED resin):

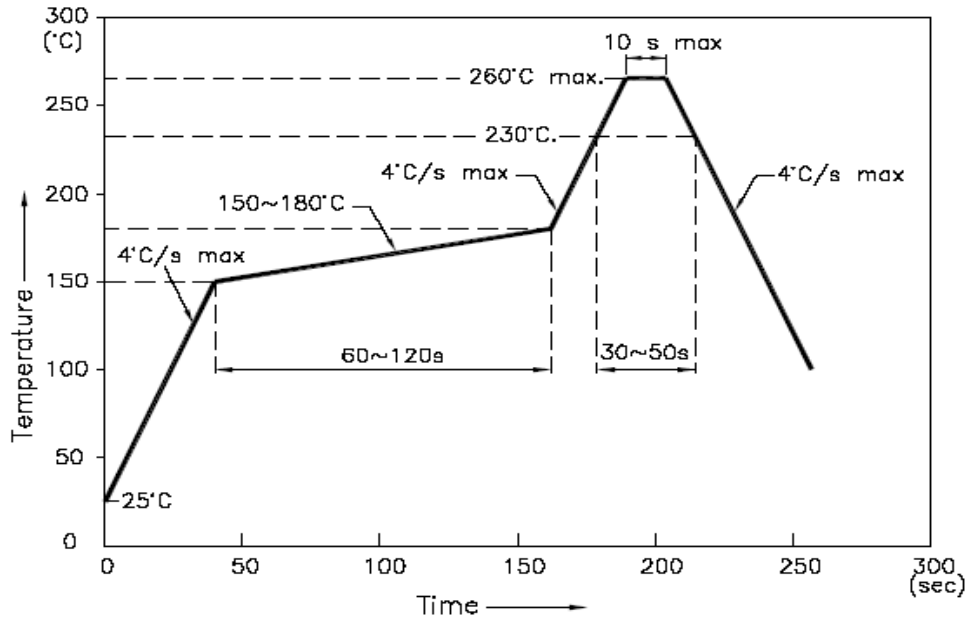

Recommended Pad Layout

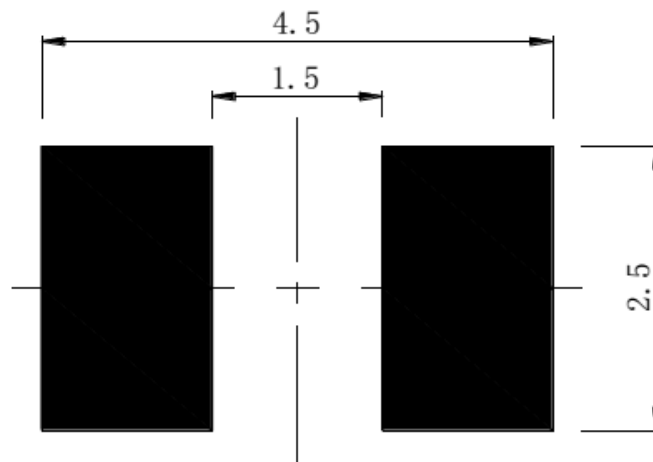

Units: mm

Tolerance: ± 0.2mm

Packing

Reel Dimension:

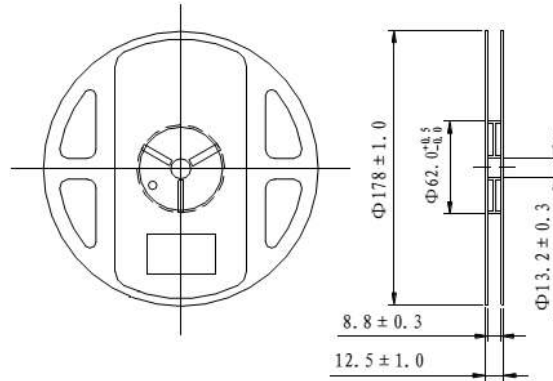

Unit: mm

Tape Dimension:

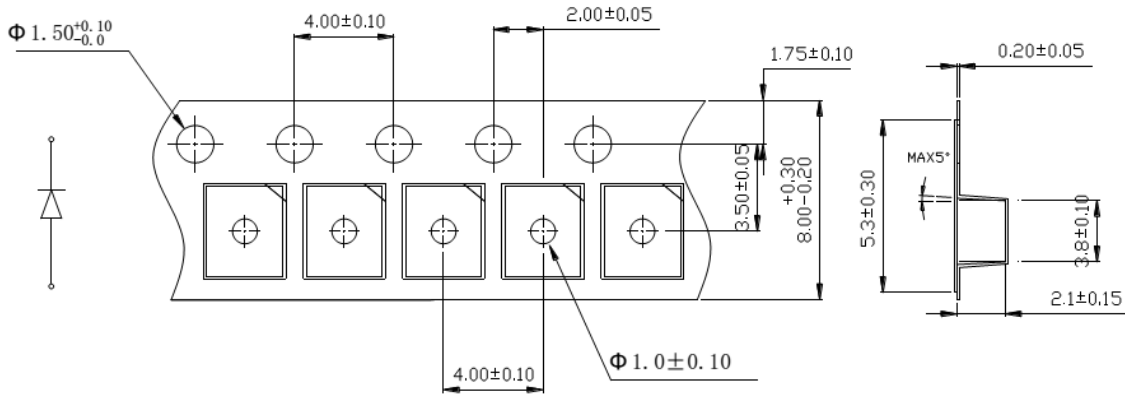

Unit: mm

Packaging Specifications:

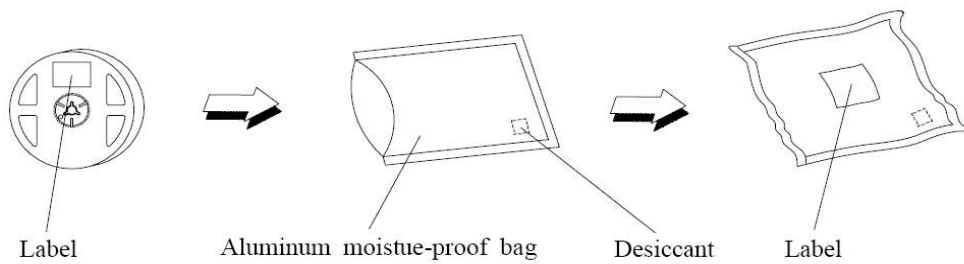

Labeling

Part No: _____

Customer P/N: _____

Item: _____

Q'ty: _____

Vf: _____

Iv: _____

WI: _____

Date: _____

Made in China**Ordering Information**

Part #	Orderable Part #	Spec Range	Quantity per reel
QBLP670-IW-WW	QBLP670-IW-WW	Iv=2400 mcd typ. @ 20mA / CCT=2760-3260K	2,000 units
QBLP670-IW-NW	QBLP670-IW-NW	Iv=2600 mcd typ. @ 20mA / CCT=3640-4240K	2,000 units
QBLP670-IW-CW	QBLP670-IW-CW	Iv=2600 mcd typ. @ 20mA / CCT=5300-7050K	2,000 units

Revision History

Description:	Revision #	Revision Date
New Release of QBLP670-IW	V1.0	03/08/2011
Add bin code/ Amend CCT Chart	V1.1	11/29/2011
Add new CCT (3640-4600K) range	V1.2	11/29/2011
Update Part Number	V1.3	02/06/2012
Update Format	V1.4	03/07/2012
Update spec and CCT binning	V2.0	08/29/2013
Update specification and binning	V2.1	09/27/2013
Update dimension tolerance	V2.2	11/21/2013
Update packing spec	V2.3	03/27/2014
Update T _{OP}	V2.4	03/18/2016

Disclaimer

QT-BRIGHTTEK reserves the right to make changes without further notice to any products herein to improve reliability, function or design. QT-BRIGHTTEK does not assume any liability arising out of the application or use of any product or circuit described herein; neither does it convey any license under its patent rights, nor the rights of others.

Life Support Policy

QT-BRIGHTTEK's products are not authorized for use as critical components in life support devices or systems without the express written approval of QT-BRIGHTTEK. As used herein:

1. Life support devices or systems are devices or systems which, (a) are intended for surgical implant into the body, or (b) support or sustain life, and (c) whose failure to perform when properly used in accordance with instructions for use provided in the labeling, can be reasonably expected to result in a significant injury of the user.
2. A critical component in any component of a life support device or system whose failure to perform can be reasonably expected to cause the failure of the life support device or system, or to affect its safety or effectiveness.