

REVISONS		DATE	BY	APPV
LOC	DIST	DESCRIPTION		
V		REVISED PER ECO-15-016251	13NOV15	KG CD

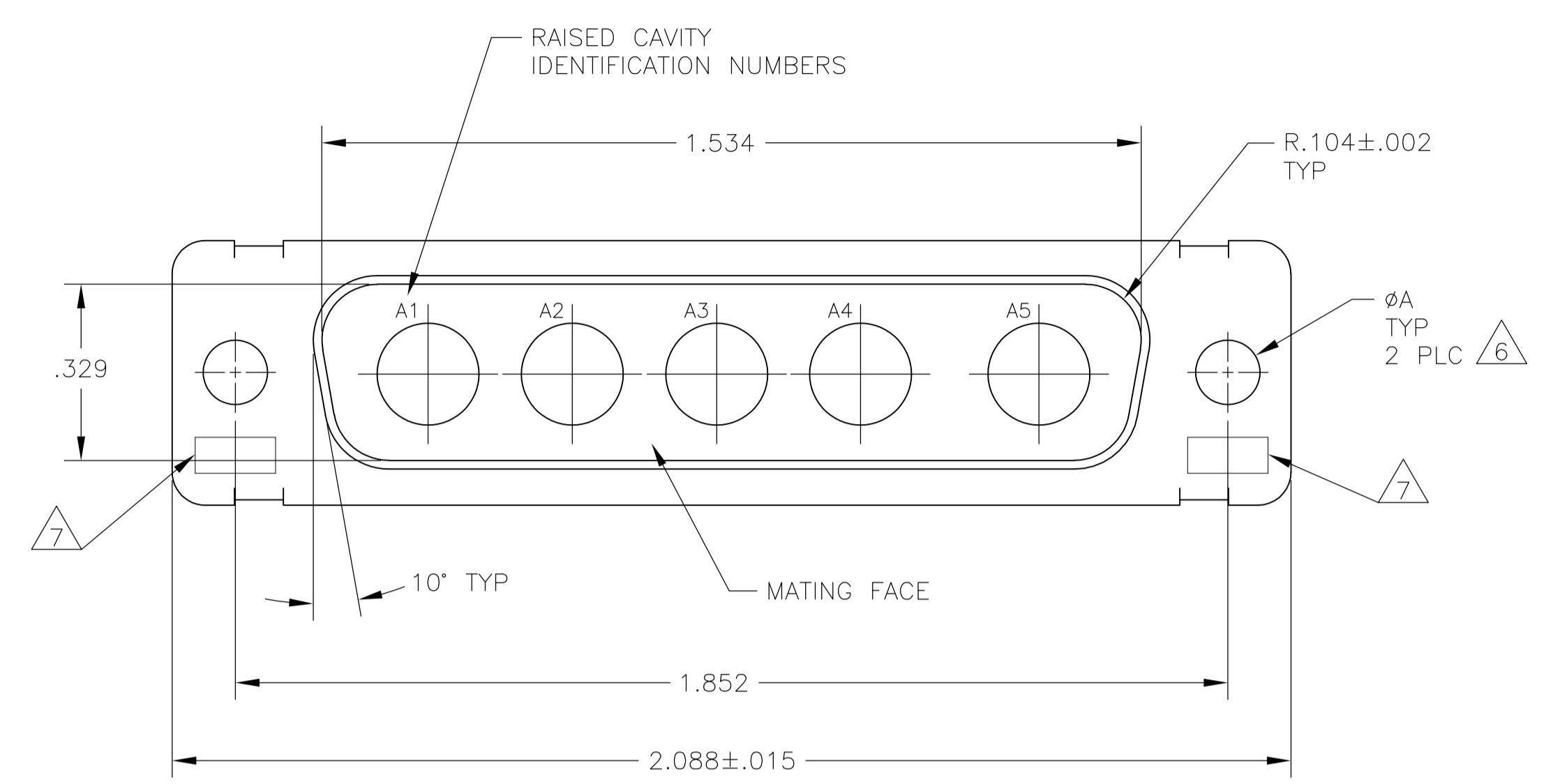

- THIS PLUG WILL MATE WITH ANY 5C5, SIZE 3 RECEPTACLE IN AMPLIMITE SERIES.
- USE (5) SIZE 8 POWER, OR COAX PIN CONTACTS. CONSULT PRODUCT ENGINEERING FOR MORE DETAILS.
- CADMIUM PLATED PER QQ-P-416, TYPE II, CLASS 2.
- FINISH: TIN PER ASTM-B-545 .000200 MIN THK OVER COPPER PER AMS2418 .000100-.000200 THK.
- GROUNDING INDENTS FOR 212491-3, 212491-5, 212491-9, 5-212491-3, & 5-212491-5 (NOT SHOWN ON DWG).
- 212491-5 & 5-212491-5 SUPPLIED WITH 4-40UNC-2B CLINCH NUTS IN THE MOUNTING HOLE LOCATIONS.
- UL/CSA DESIGNATION STAMPED IN THIS AREA, OPTIONAL.
- STEEL PER ASTM-A-109.
- BRASS PER ASTM-B-36 AND MIL-C-50.
- FINISH: PLATED GOLD PER MIL-G-45204, TYPE II, GRADE C OVER COPPER PLATE PER MIL-C-14550, CLASS IV.
- FINISH: TIN PER ASTM-B-545 .000400 MIN THK OVER COPPER PER AMS2418 .000050 MIN THK.
- FINISH: ZINC PLATE PER ASTM-B-633 .000200-.000400 THK WITH SUPPLEMENTARY CHROMATE (Cr3+).

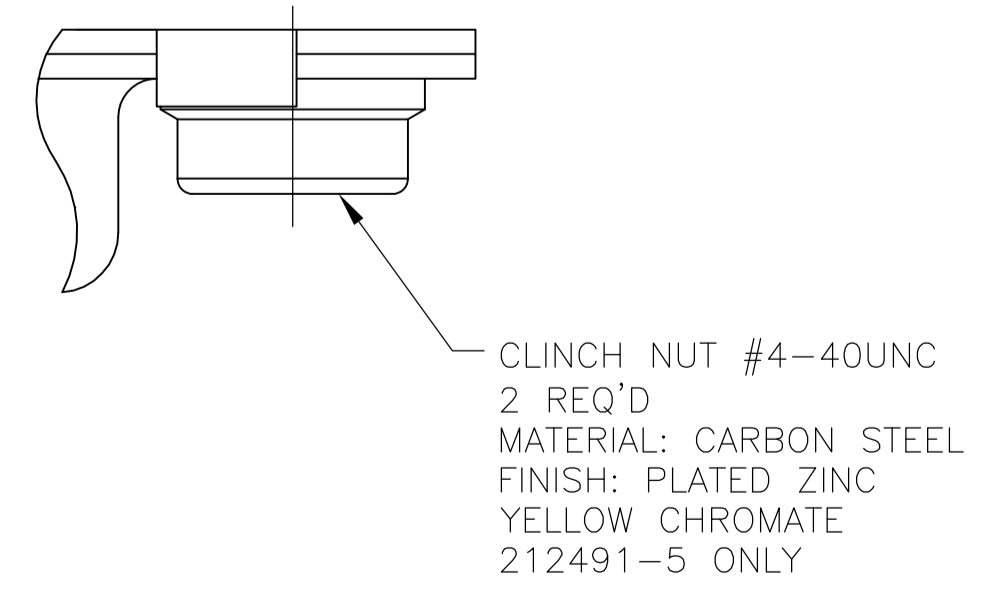
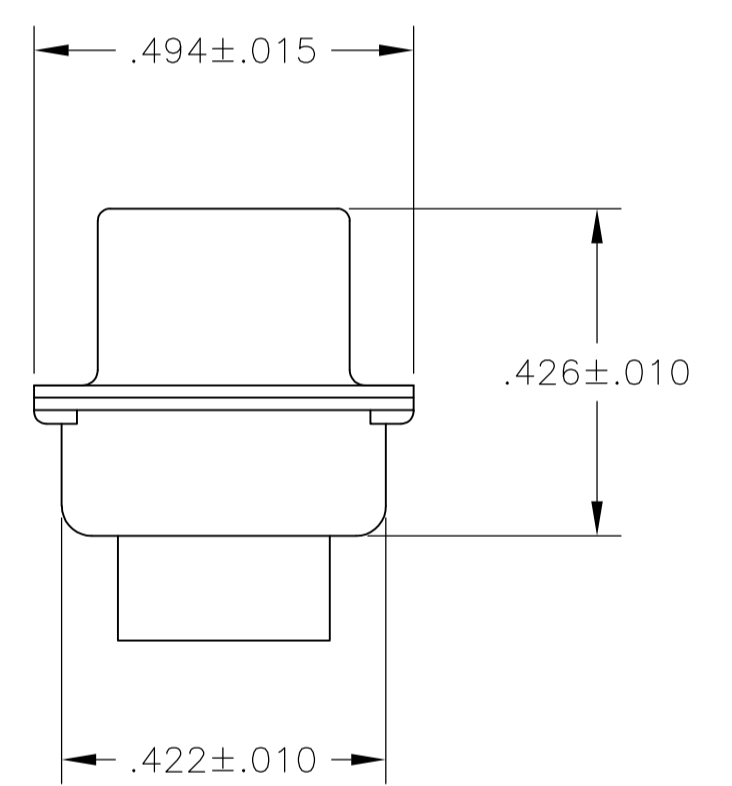
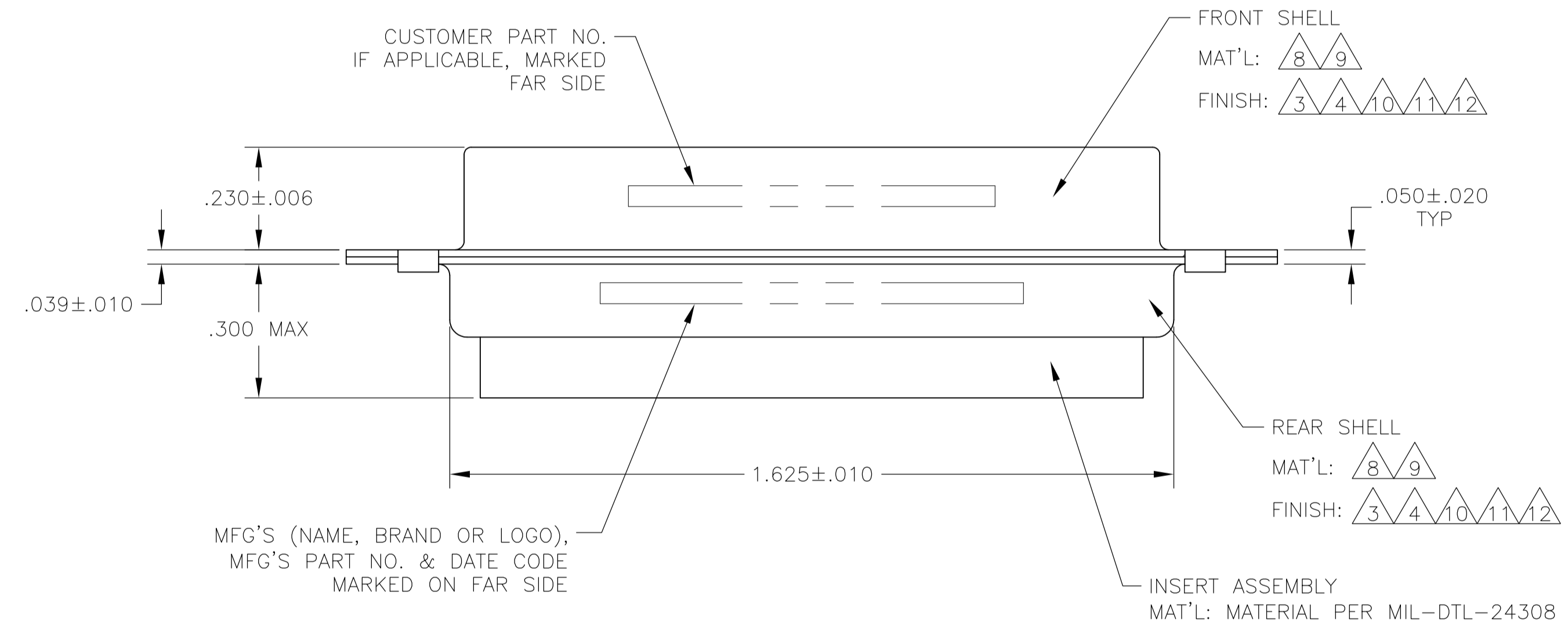

NOT RELEASED FOR PRODUCTION

CUSTOMER PART NO.	φA	REMARKS	PART NO.
NOT APPLICABLE	△6	△5△8△11	5-212491-5
NOT APPLICABLE	.120	△5△8△11	5-212491-3
NOT APPLICABLE	.120	△8△12	5-212491-1
NOT APPLICABLE	.120	△8△11	1-212491-0
NOT APPLICABLE	.120	△5△8△11	212491-9
B010942-0015	.120	△9△10	212491-8
311P405-10P-B-15	.154	△9△10	212491-7
311P405-10P-B-12	.120	△9△10	212491-6
NOT APPLICABLE	△6	△4△5△8	212491-5
97942-645A935H02	.120	△3△8	212491-4
NOT APPLICABLE	.120	△4△5△8	212491-3
NOT APPLICABLE	.120	△3△8	212491-2
NOT APPLICABLE	.120	△3△8	212491-1
CUSTOMER PART NO.	φA	REMARKS	PART NO.

THIS DRAWING IS A CONTROLLED DOCUMENT. **STE** TE Connectivity

DIMENSIONS: INCHES	TOLERANCES UNLESS OTHERWISE SPECIFIED:	0 PLC ± -	1 PLC ± -	2 PLC ± -	3 PLC ± .005(0.13)	4 PLC ± -	ANGLES ± 0°30'
MATERIAL	FINISH	WEIGHT	SCALE	SHEET	REV	CUSTOMER DRAWING	

APPROVED: MANJUNATH G.M. 27-May-15
 CHARLES THOMAS 27-May-15
 CHARLES THOMAS 27-May-15

NAME: PLUG ASSEMBLY AMPLIMITE 5C5 SIZE 3, SERIES 109, COAX MIX

SIZE: A1 00779 C=212491

SCALE: 4:1 SHEET: 1 OF 1 REV: V