

ASMT-CW00
InGaN White, 0.4mm Low Profile
Right Angle Surface Mount ChipLED



Data Sheet

Description

The ASMT-CW00 of white color chip-type LEDs is designed with the smallest footprint to achieve high density of components on board. They have the industry standard footprint 1.6 mm x 1.0 mm and a height of only 0.4 mm. This makes them very suitable for cellular phone and mobile equipment backlighting and indication application where space is a constraint. In order to facilitate automated pick and place operation, these ChipLEDs are shipped in conductive tape and reel, with 4000 units per reel. These part are compatible with IR soldering.

Features

- Small size right angle mount
- 0603 industry standard footprint
- 0.4 mm low profile type
- Operating temperature range of -40°C to +85 °C
- Compatible with IR reflow soldering process
- Available in 8mm tape on 178mm (7') diameter reels
- Reel sealed in zip locked moisture barrier bags

Applications

- LCD Backlighting
- Keypad Side / Backlighting
- Pushbutton backlighting
- Symbol Indicator

Package Dimension

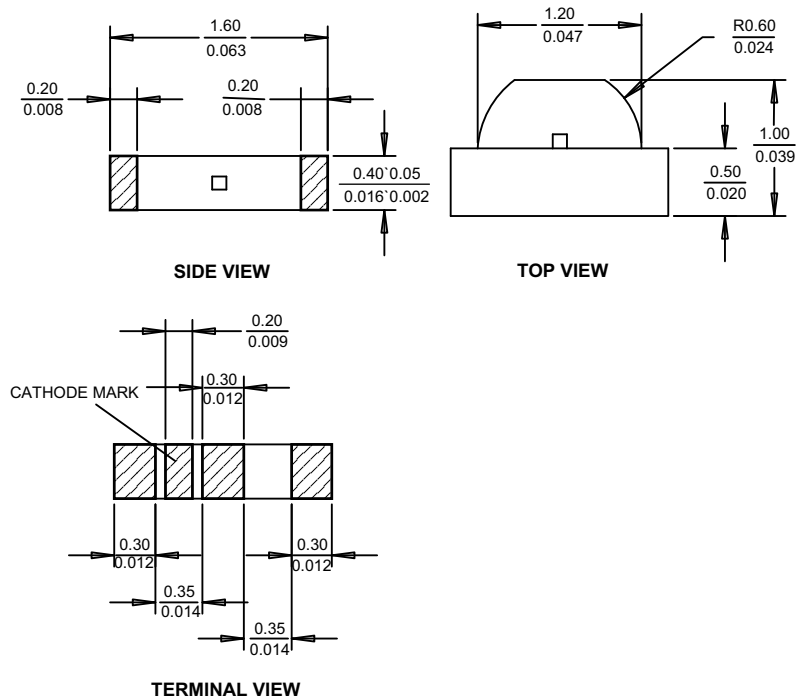

Notes:

1. All dimensions will be in millimeters (inches)
2. Tolerance is ±0.1mm (±0.004 in) unless otherwise stated

CAUTION: ASMT-CW00 LEDs are Class 1A ESD sensitive per JESD22-A114C.01. Please observe appropriate precautions during handling and processing. Refer to Application Note AN-1142 for additional details.

Device Selection Guide

Package Dimension (mm)	Parts per Reel	Package Description
1.6 (L) x 1.0 (W) x 0.4 (H)	4000	Untinted, Non-diffused

Absolute Maximum Ratings at $T_A = 25^\circ\text{C}$

Parameter	ASMT-CW00	Unit
DC Forward Current ^[1]	10	mA
Power Dissipation	32	mW
Reverse Voltage ($I_R = 100\mu\text{A}$)	5	V
LED Junction Temperature	95	$^\circ\text{C}$
Operating Temperature Range	-40 to +85	$^\circ\text{C}$
Storage Temperature Range	-40 to +85	$^\circ\text{C}$
Soldering Temperature	See reflow soldering profile (Figure 8 & 9)	

Note:

1. Derate linearly as shown in Figure 4.

Electrical Characteristics at $T_A = 25^\circ\text{C}$

Part Number	Forward Voltage V_F (Volts) ^[1] @ $I_F = 5\text{mA}$		Reverse Breakdown V_R (Volts) @ $I_R = 100\mu\text{A}$	Thermal Resistance $R_{\theta\text{J-PIN}}$ ($^\circ\text{C}/\text{W}$)
	Min.	Max.	Minimum	Typical
ASMT-CW00	2.55	3.15	5	450

Notes:

1. V_F tolerance : $\pm 0.1\text{V}$

Optical Characteristics at $T_A = 25^\circ\text{C}$

Part Number	Luminous Intensity I_V ^[1] (mcd) @ 5mA		Color Chromaticity ^[2]	Viewing Angle $2\theta_{1/2}$ ^[3] (Degrees)
	Min.	Typ.	Bin	Typical
ASMT-CW00	18	35	A1 – D2 (Refer to Figure 1)	170

Notes:

1. The luminous intensity I_V is measured at the peak of the spatial radiation pattern which may not be aligned with the mechanical axis of the LED package.
2. The chromaticity coordinates are derived from the CIE Chromaticity Diagram and represents the perceived color of the device.
3. $\theta_{1/2}$ is the off-axis angle where the luminous intensity is $1/2$ the peak intensity.

Light Intensity (I_V) Bin Limits

Bin ID	Intensity (mcd)	
	Minimum	Maximum
M	18.00	28.50
N	28.50	45.00
P	45.00	71.50
Q	71.50	112.50

Tolerance : $\pm 15\%$

Notes:

- Bin categories are established for classification of products. Products may not be available in all categories. Please contact your Avago representative for information on current available bins.

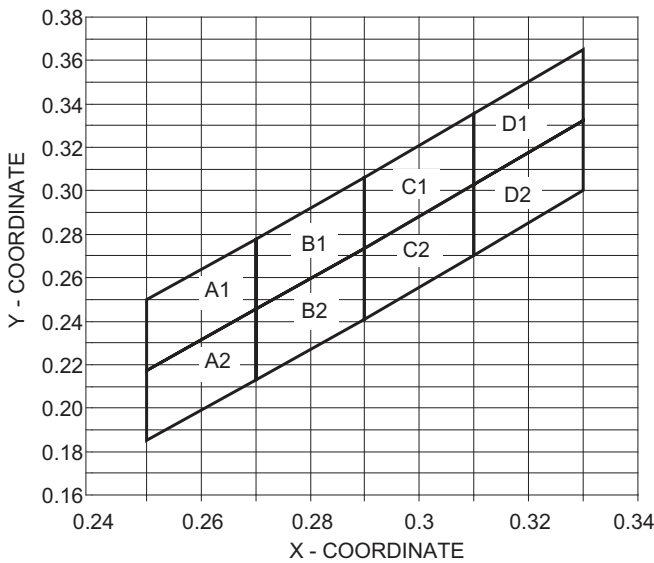

Figure 1. Color bin limits (CIE 1931 Chromaticity Diagram) [Tolerance: ± 0.02]

Forward Voltage (V_F) Bin Limits

Bin ID	Forward Voltage (V)	
	Minimum	Maximum
1	2.55	2.75
2	2.75	2.95
3	2.95	3.15

Tolerance : $\pm 0.1V$

Rank	Chromaticity Coordinates					
		X	Y	Z	u'	v'
A1	X	0.2700	0.2700	0.2500	0.2500	
	Y	0.2455	0.2780	0.2500	0.2175	
A2	X	0.2700	0.2700	0.2500	0.2500	
	Y	0.2455	0.2130	0.1850	0.2175	
B1	X	0.2700	0.2700	0.2900	0.2900	
	Y	0.2455	0.2780	0.3060	0.2735	
B2	X	0.2700	0.2700	0.2900	0.2900	
	Y	0.2455	0.2130	0.2410	0.2735	
C1	X	0.2900	0.3100	0.3100	0.2900	
	Y	0.3060	0.3355	0.3030	0.2735	
C2	X	0.2900	0.3100	0.3100	0.2900	
	Y	0.2410	0.2705	0.3030	0.2735	
D1	X	0.3100	0.3100	0.3300	0.3300	
	Y	0.3030	0.3355	0.3650	0.3325	
D2	X	0.3100	0.3100	0.3300	0.3300	
	Y	0.3030	0.2705	0.3000	0.3325	

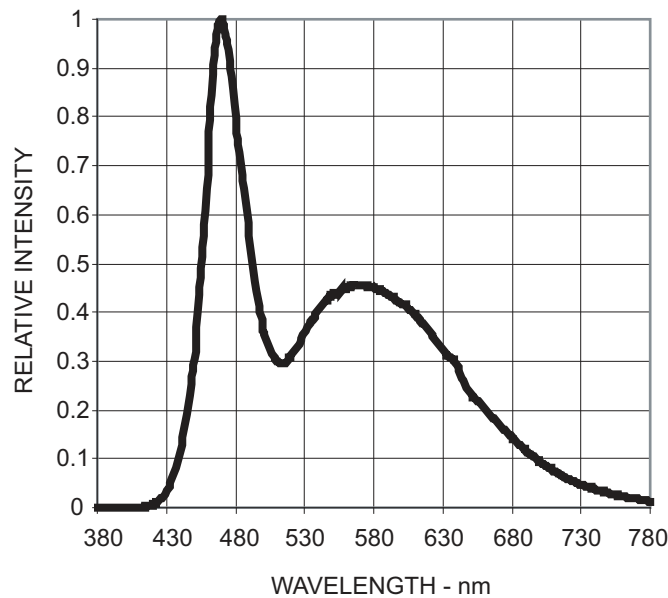

Figure 2. Relative intensity vs. wavelength

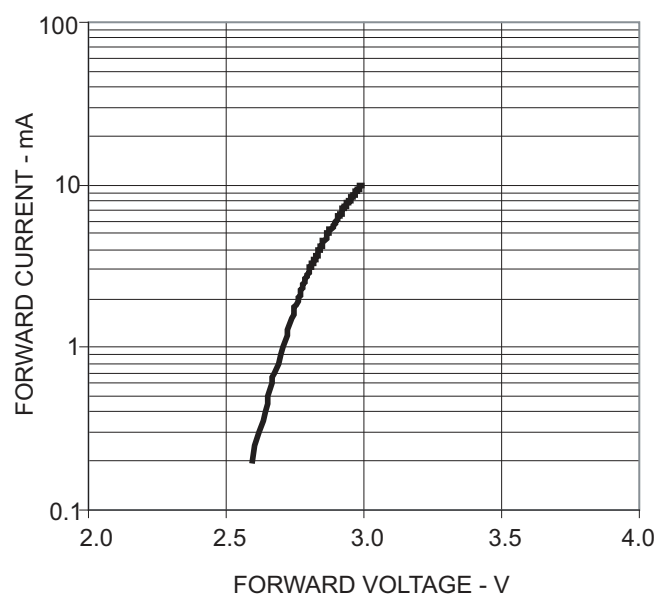

Figure 3. Forward voltage vs. forward current

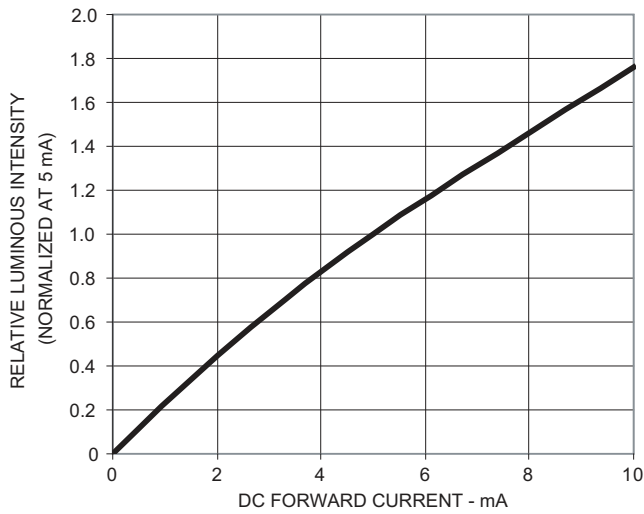

Figure 4. Luminous intensity vs. forward current

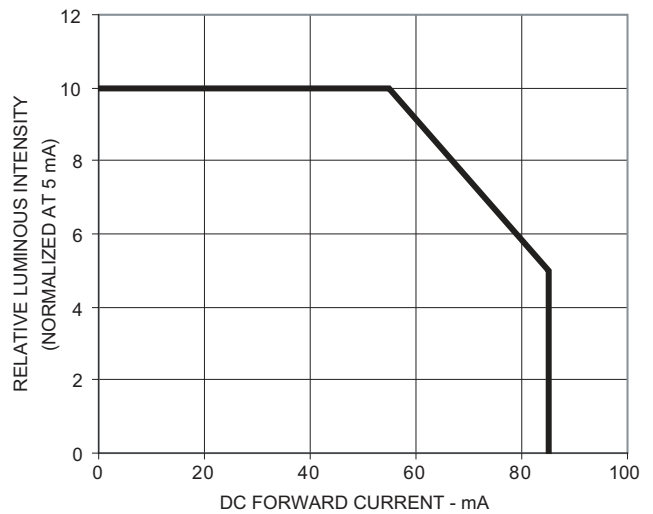

Figure 5. Maximum forward current vs. ambient temperature

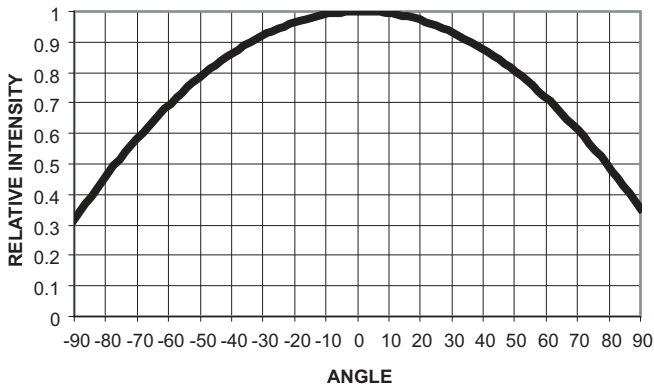
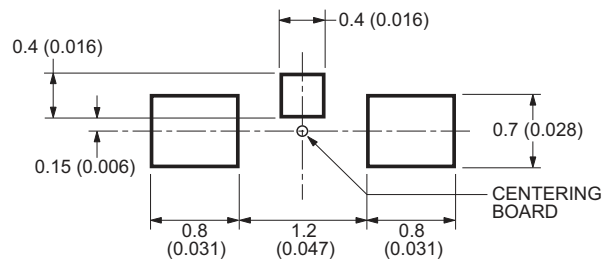

Figure 6. Radiation pattern



- Notes:
 1. All dimensions are in millimeters (inches).
 2. Tolerance is $\pm 0.1\text{mm}$ ($\pm 0.004\text{in.}$) unless otherwise specified

Figure 7. Recommended soldering land pattern

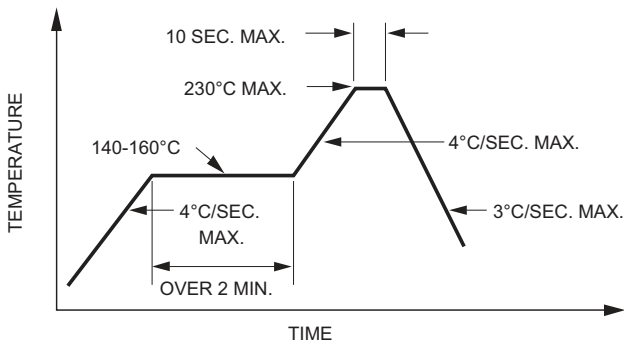

Figure 8. Recommended reflow soldering profile

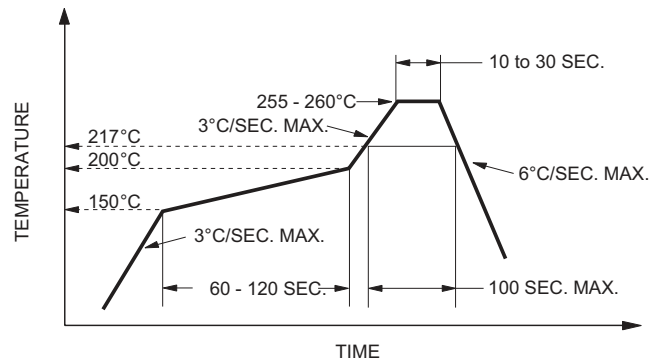
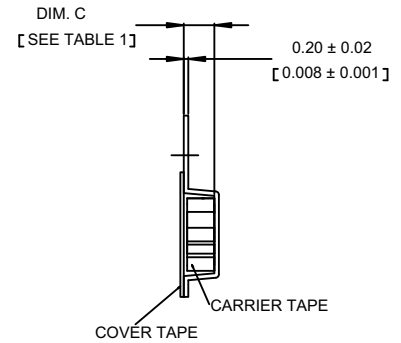
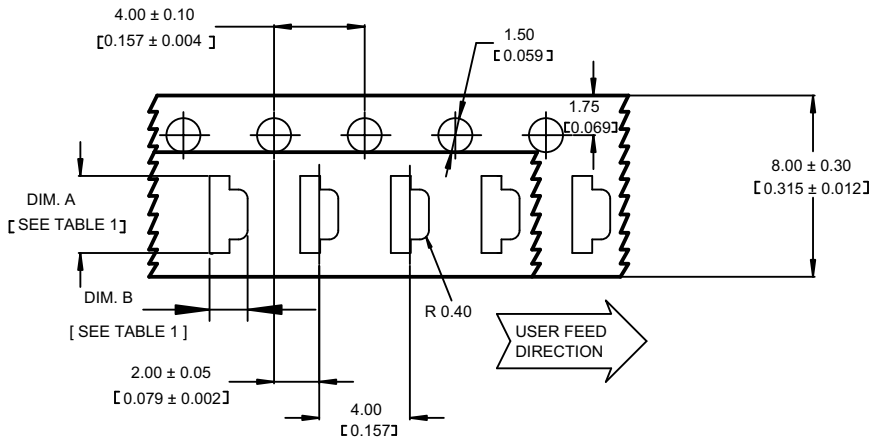

Figure 9. Recommended Pb-free reflow soldering profile



Notes:

1. All dimensions are in millimeters (inches).
2. Tolerance is $\pm 0.1\text{mm}$ ($\pm 0.004\text{in.}$) unless otherwise specified.

Table 1.

PART NUMBER	DIM.A ± 0.10 (0.004)	DIM.B ± 0.10 (0.004)	DIM.C ± 0.10 (0.004)
ASMT-CW00	1.75 (0.069)	1.10 (0.043)	0.60 (0.024)

Dimensions In Millimeters (Inches)

Figure 12. Tape dimensions

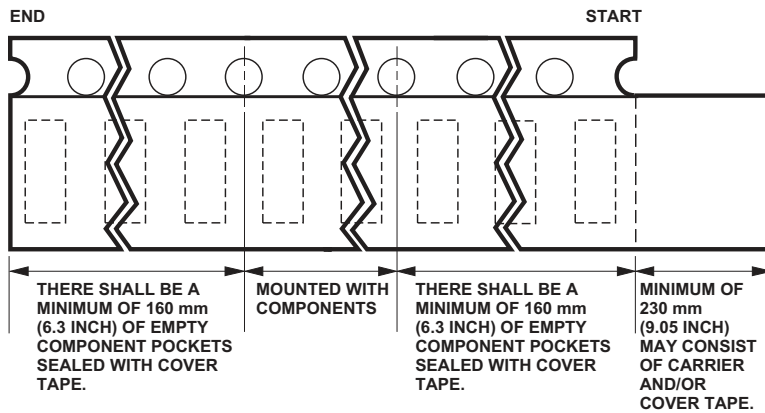

Figure 13. Tape leader and trailer dimensions

Reflow Soldering

For more information on reflow soldering, refer to Application Note AN-1060, Surface Mounting SMT LED Indicator Components.

Storage Condition

5 to 30°C @ 60%RH max. Baking is required before mounting, if

1. Humidity Indicator Card is $> 10\%$ when read at $23 \pm 5^\circ\text{C}$.
2. Device expose to factory conditions $< 30^\circ\text{C}/60\%RH$ more than 672 hours.

Recommended baking condition: $60 \pm 5^\circ\text{C}$ for 20 hours.

For product information and a complete list of distributors, please go to our web site: www.avagotech.com