

Ø 32 mm 3.9 Watts 3.9 W with tags Part number 82860041



- Nominal power : 3 W
- Versions with tag or lead connection
- Versions without filter or with standard filter or class B filter built into the motor
- Versions with or without encoder, 1 or 5 pulses per revolution, built into the motor

Part numbers

	Type	Type	Voltage	References
82860041	3.9 W with tags	82860	24 V	With class B EMC filter

Specifications

No-load characteristics

Speed of rotation (rpm)	5000
Absorbed power (W)	1,92
Absorbed current (A)	0,08

Nominal characteristics

Speed (rpm)	3700
Torque (mNm)	7,7
Usable power (W)	3
Absorbed power (W)	6
Absorbed current (A)	0,26
Gearbox case temperature rise (°C)	50
Efficiency (%)	50

General characteristics

Insulation class (conforming to IEC 85)	B (130 °C)
Protection rating	IP40
Max. output power (W)	3,9
Start torque (mNm)	30
Starting current (A)	0,76
Resistance (Ω)	32
Inductance (mH)	41,6
Torque constant (Nm/A)	0,0448
Electrical time constant (ms)	1,3
Mechanical time constant (ms)	36
Thermal time constant (mn)	8
Inertia (g.cm ²)	19
Weight (g)	95
Number of segments	3
Service life (h)	3000
Sintered bronze bearings	■
Leads connection 250 mm	-

Encoder characteristics

Connection	AWG24
Output current (mA)	< 20
Supply (V)	4,5 →30 DC

Made to order products, available on request

- Other supply voltages
- Motor with 2 ball bearings
- Shaft lengths at front and/or rear
- Lead outputs or radial tag terminals
- Special interference suppression
- Encoder : 5 pulses/rev

Dimensions (mm)

82 860 0 without encoder

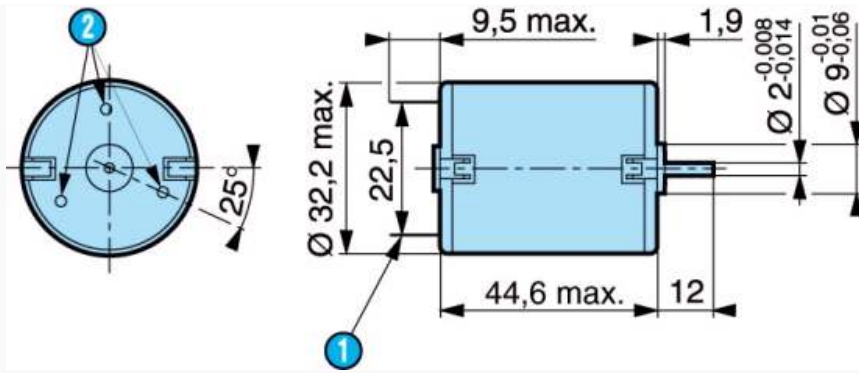

N°	Legend
1	3 holes at 120 °C over Ø 26 mm : use self-tapping M2.2 screws ; screw depth max. 6 mm
2	2 tags NFC 20 - 120, series 2.8 x 0.5

Curves

82860

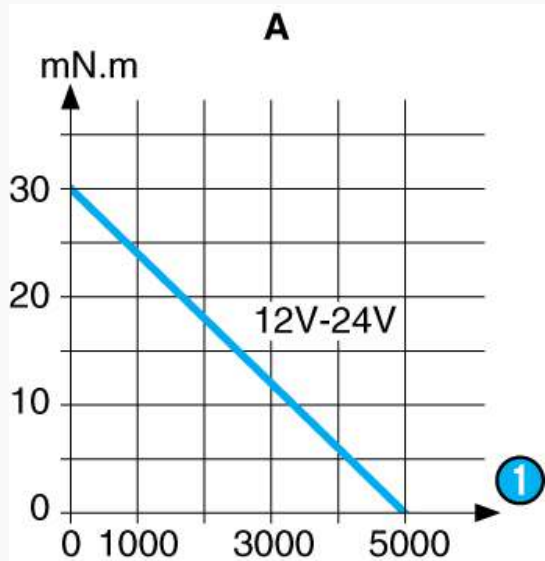

N°	Legend
1	rpm
	Torque/nominal speed curve
Torque/nominal speed curves	
Torque/current curves	

Curves

82860

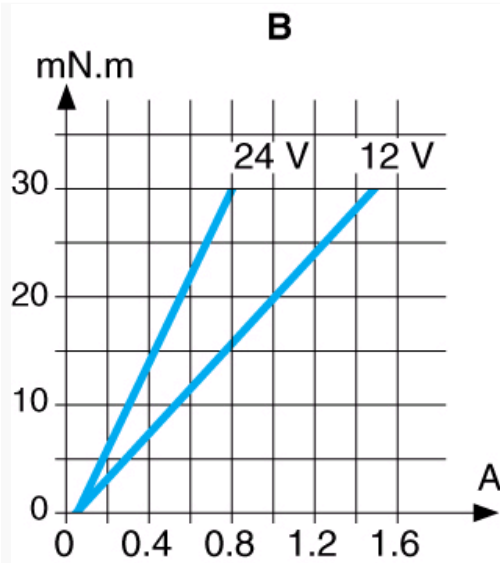

N°	Legend
	Torque/current curve

Product adaptations



- Special output shaft
- Pinion on output shaft
- Special supply voltage
- Special cable length
- Special ball bearings
- Special mounting plate
- Customised electronics
- Special connectors
- Shorter 1 W motor