

ROWS AG & EG RECOMMENDED FOR ALL APPLICATIONS. THESE ROWS SHOULD BE CONNECTED TO GROUND.

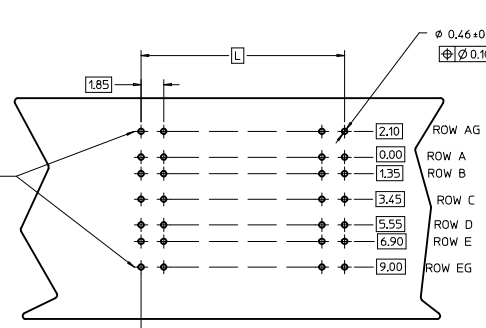

PLATED THRU HOLE (Ø0.57 DRILL) (Ø0.88 PAD)

BACKPLANE HOLE PATTERN (COMPONENT SIDE 10-POSITION SHOWN)

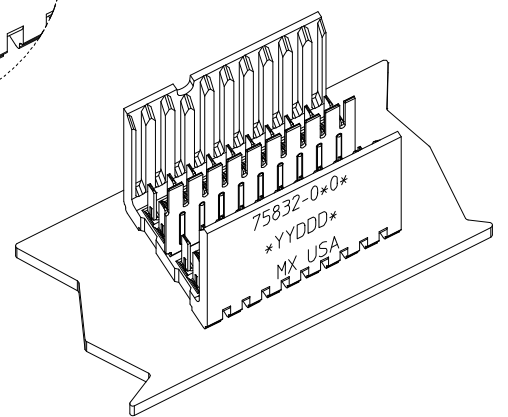
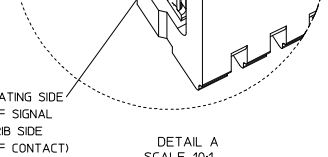
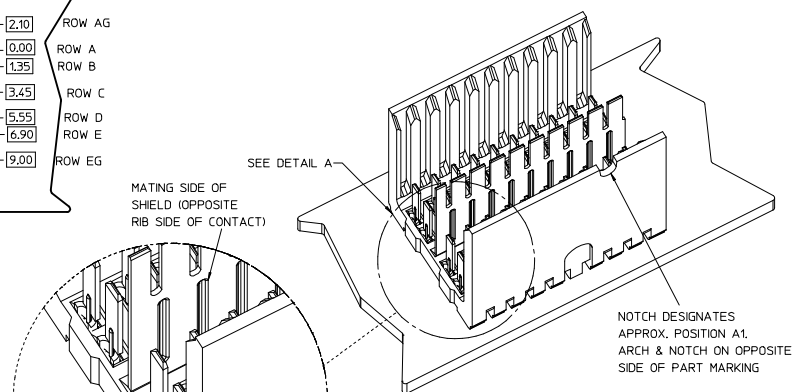
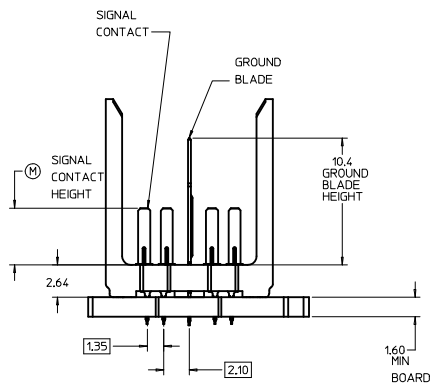
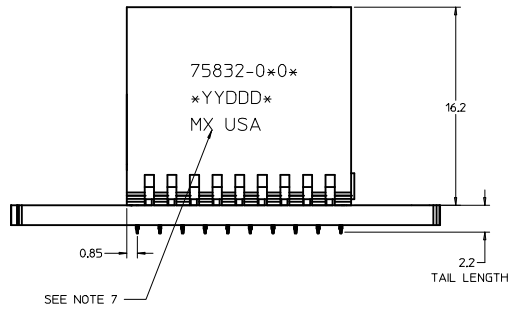

LEAD-FREE PLATING ON SIGNALS, & GROUNDS.

- NOTES:**
- MATERIAL: HOUSING - LIQUID CRYSTAL POLYMER (LCP) GLASS-FILLED. UL 94V-0, COLOR - GRAY. SIGNAL CONTACT AND GROUND BLADE - HIGH PERFORMANCE COPPER ALLOY.
 - FINISHES: SELECTIVE GOLD (Au) ON CONTACT AREA, SELECTIVE MATTE TIN (Sn) ON PCB TAILS, NICKEL (Ni) OVERALL.
 - THIS PART CONFORMS TO MOLEX PRODUCT SPECIFICATION PS-75221-999.
 - FOR MIXED CONTACT MATING LENGTHS CONSULT MOLEX FOR AVAILABILITY. CONTACT PAIRS MUST BE THE SAME LENGTH.
 - FOR SPECIFIC PART NUMBER AND MATING INFORMATION PLEASE REFER TO CHART.
 - PACKAGE PER PK-70873-5058.
 - EITHER MARK PART NUMBER AND DATE CODE APPROXIMATELY WHERE SHOWN OR PLACE A LABEL ON THE TUBE.
 - THESE PARTS CONFORM TO MOLEX COSMETIC SPECIFICATION PS-45499-002 CLASS B.
 - MAPS (MOLEX ADVANCED PLATING SYSTEM).

75832-**0*		PIN LENGTH DIM *M*	GOLD (Au) THICKNESS micrometers	
COLUMNS 01 = 10 COL 02 = 25 COL 05 = 5 COL	KEYING ORIENTATION OPEN = 0 (NONE)	0-3.55 mm	0.25 (MAPS)	
		1-4.55 mm		
		2-5.55 mm		
		3-3.55 mm	0.76	
		4-4.55 mm		
		5-5.55 mm		
		7-3.55 mm		1.27
		8-4.55 mm		
		9-5.55 mm		

PART NUMBER TABLE				
ASSY PART NO.	K	L	P	TOTAL NO. OF DIFFERENTIAL PAIRS
75832-050*	4	7.40	9.10	10
75832-010*	9	16.65	18.35	20
75832-020*	24	44.40	46.10	50

ADD MAPS EC NO: UCP2013-5239 D DRWNS/ANG01 2013/06/03 CHYK/MOLFE 2013/06/03 APPRS/MILLER 2014/02/03 REV DESCRIPTION	QUALITY SYMBOLS	GENERAL TOLERANCES (UNLESS SPECIFIED)	DIMENSION STYLE	SCALE	DESIGN UNITS	THIRD ANGLE PROJECTION
	▽=0	4 PLACES ± mm ± INCH	MM ONLY	5:1	METRIC	
	▽=0	3 PLACES ± mm ± INCH				
	▽=0	2 PLACES ± 0.13 ± INCH				
		0 PLACE ± 0.25 ± INCH				
		ANGULAR ± ° ± ' ± "				
		DRAFT WHERE APPLICABLE MUST REMAIN WITHIN DIMENSIONS				
			MATERIAL NO.	DOCUMENT NO.		
			SEE TABLE	SD-75832-010		
			THIS DRAWING CONTAINS INFORMATION THAT IS PROPRIETARY TO MOLEX INCORPORATED AND SHOULD NOT BE USED WITHOUT WRITTEN PERMISSION			

TITLE: GBX 2-PAIR OPEN END BACKPLANE ASSEMBLY LEAD-FREE SALES DRAWING

molex

SHEET NO. 1 OF 1

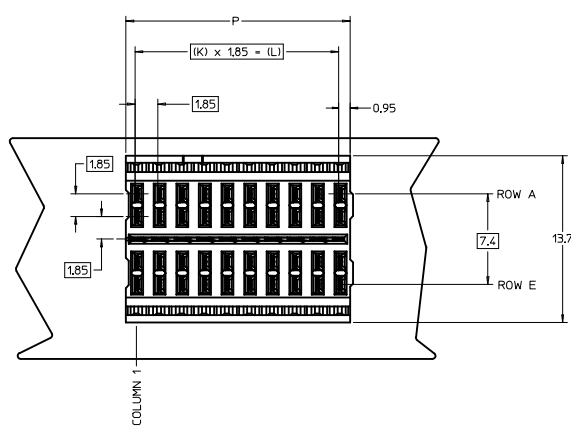

ROWS AG & EG RECOMMENDED FOR ALL APPLICATIONS. THESE ROWS SHOULD BE CONNECTED TO GROUND.

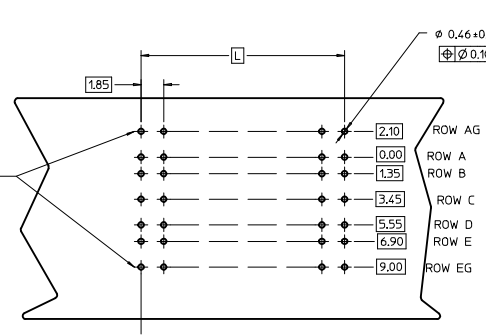

PLATED THRU HOLE (Ø0.57 DRILL) (Ø0.88 PAD)

BACKPLANE HOLE PATTERN (COMPONENT SIDE 10-POSITION SHOWN)

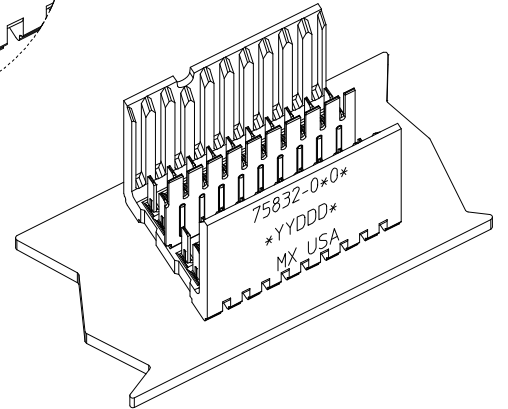
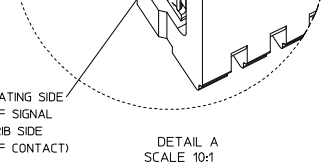
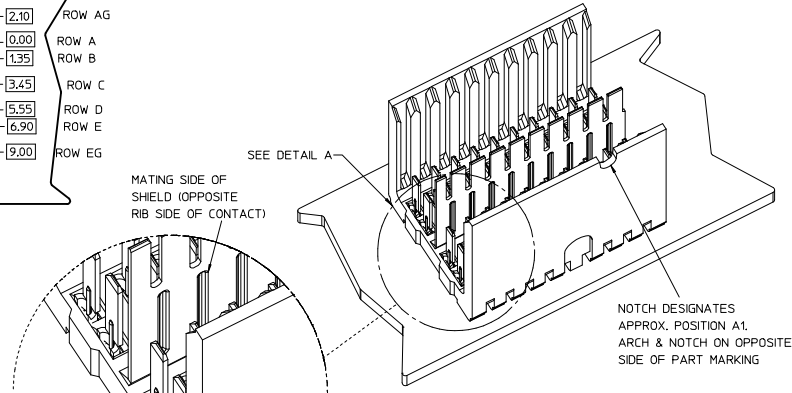
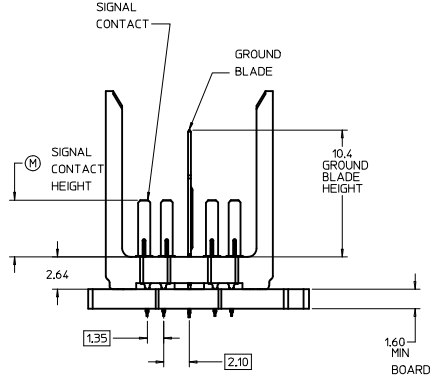
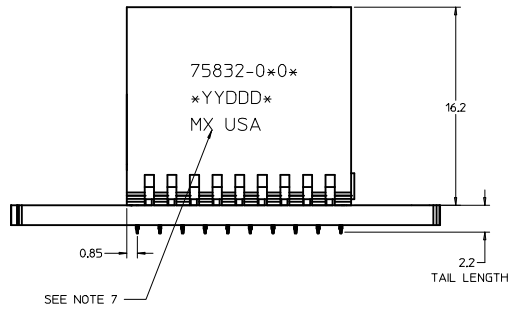

75832- * 0*		PIN LENGTH DIM *M*	GOLD (Au) THICKNESS micrometers	
COLUMNS 01 = 10 COL 02 = 25 COL 05 = 5 COL	KEYING ORIENTATION OPEN = 0 (NONE)	0-3.55 mm	0.25 (MAPS)	
		1-4.55 mm		
		2-5.55 mm		
		3-3.55 mm	0.76	
		4-4.55 mm		
		5-5.55 mm		
		7-3.55 mm		1.27
		8-4.55 mm		
		9-5.55 mm		

LEAD-FREE PLATING ON SIGNALS, & GROUNDS.

- NOTES:
- MATERIAL: HOUSING - LIQUID CRYSTAL POLYMER (LCP) GLASS-FILLED. UL 94V-0, COLOR - GRAY. SIGNAL CONTACT AND GROUND BLADE - HIGH PERFORMANCE COPPER ALLOY.
 - FINISHES: SELECTIVE GOLD (Au) ON CONTACT AREA, SELECTIVE MATTE TIN (Sn) ON PCB TAILS, NICKEL (Ni) OVERALL.
 - THIS PART CONFORMS TO MOLEX PRODUCT SPECIFICATION PS-75221-999.
 - FOR MIXED CONTACT MATING LENGTHS CONSULT MOLEX FOR AVAILABILITY. CONTACT PAIRS MUST BE THE SAME LENGTH.
 - FOR SPECIFIC PART NUMBER AND MATING INFORMATION PLEASE REFER TO CHART.
 - PACKAGE PER PK-70873-5058.
 - EITHER MARK PART NUMBER AND DATE CODE APPROXIMATELY WHERE SHOWN OR PLACE A LABEL ON THE TUBE.
 - THESE PARTS CONFORM TO MOLEX COSMETIC SPECIFICATION PS-45499-002 CLASS B.
 - MAPS (MOLEX ADVANCED PLATING SYSTEM).

PART NUMBER TABLE				
ASSY PART NO.	K	L	P	TOTAL NO. OF DIFFERENTIAL PAIRS
75832-050*	4	7.40	9.10	10
75832-010*	9	16.65	18.35	20
75832-020*	24	44.40	46.10	50

ADD MAPS EC NO: UCP2013-5239 D DRWNS/ANG01 2013/06/03 CHYK/MOLFE 2013/06/03 APPRS/MILLER 2014/02/03 REV DESCRIPTION	QUALITY SYMBOLS	GENERAL TOLERANCES (UNLESS SPECIFIED)	DIMENSION STYLE	SCALE	DESIGN UNITS	THIRD ANGLE PROJECTION
	▽=0	4 PLACES ± mm ± INCH	MM ONLY	5:1	METRIC	
	▽=0	3 PLACES ± mm ± INCH				
	▽=0	2 PLACES ± 0.13 ± INCH				
		0 PLACE ± 0.25 ± INCH				
		ANGULAR ± ° ± ' ± "				
		DRAFT WHERE APPLICABLE MUST REMAIN WITHIN DIMENSIONS				
			MATERIAL NO.	DOCUMENT NO.		
			SEE TABLE	SD-75832-010		
			THIS DRAWING CONTAINS INFORMATION THAT IS PROPRIETARY TO MOLEX INCORPORATED AND SHOULD NOT BE USED WITHOUT WRITTEN PERMISSION			

TITLE: GBX 2-PAIR OPEN END BACKPLANE ASSEMBLY LEAD-FREE SALES DRAWING

molex

SHEET NO. 1 OF 1