

REVISIONS

P	LTR	DESCRIPTION	DATE	DWN	APVD
	E	PKG IS CHANGED FROM BOX TO TRAY	22FEB2018	RK	PS

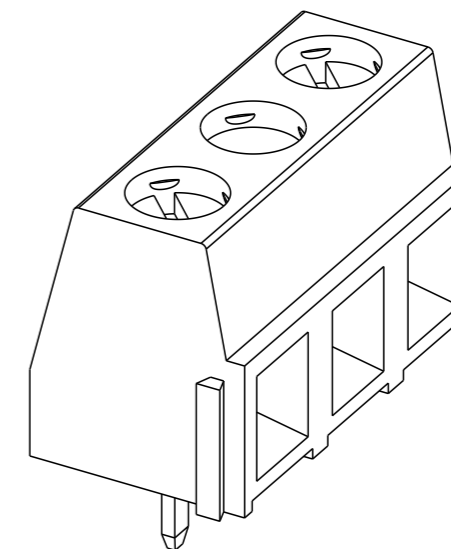

282838-2 AS SHOWN

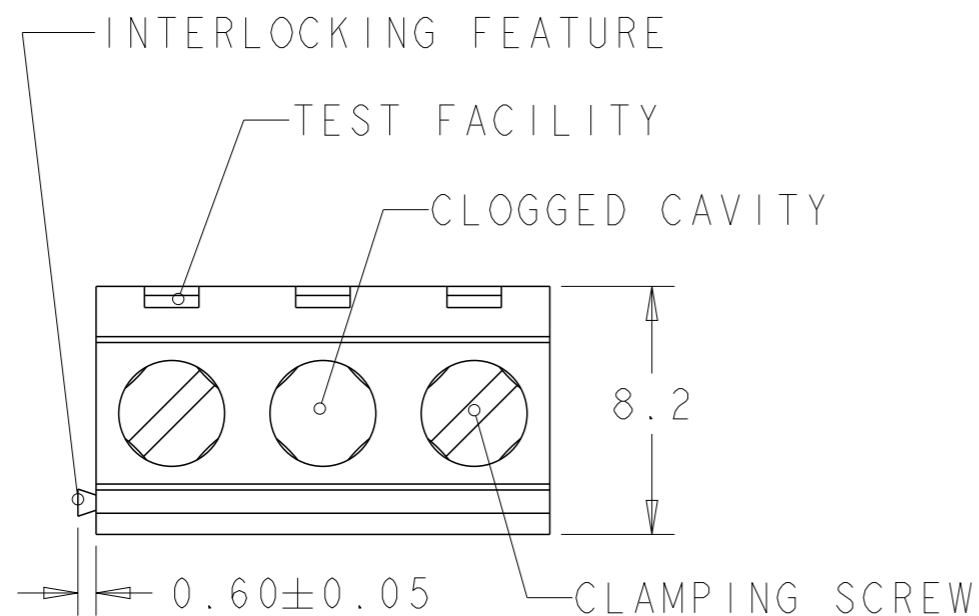
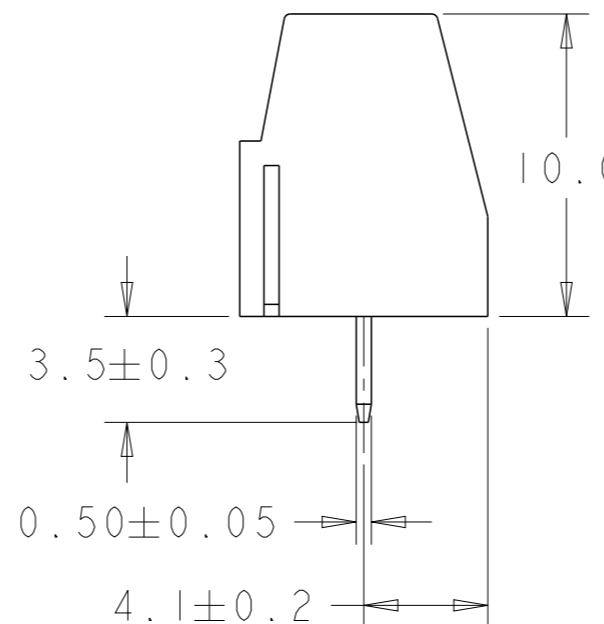
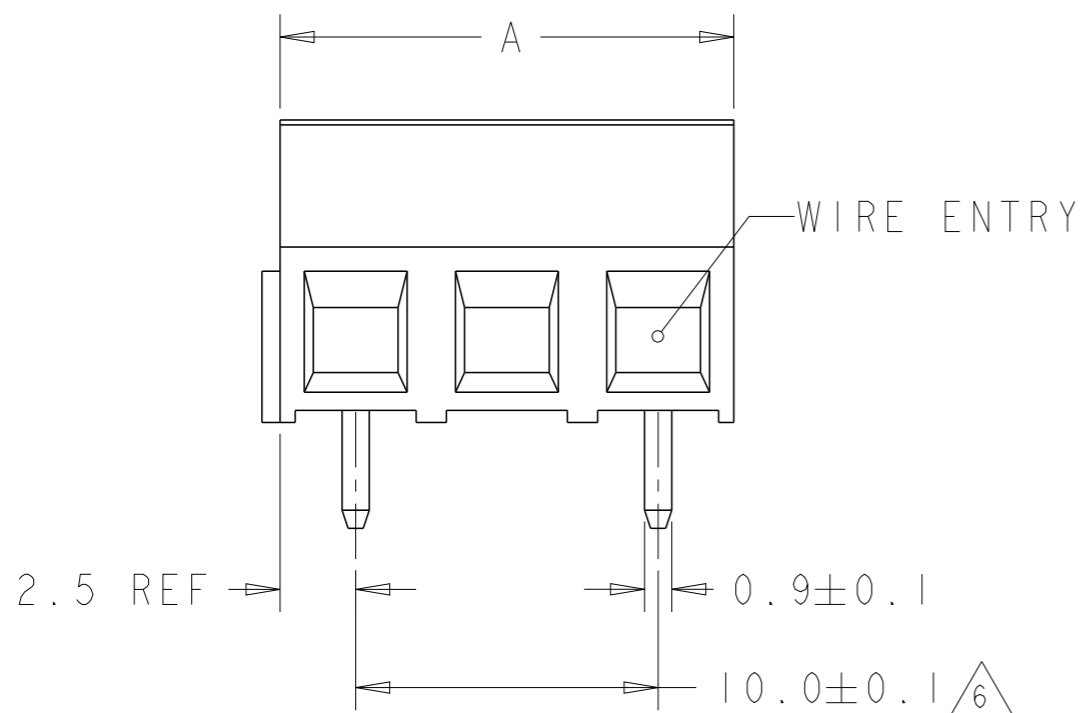

MARKING	DIM. A	NO OF POS.	PART NUMBER	
OBSOLETE	125	13	1-282838-4	
	115	12	1-282838-3	
	105	11	1-282838-2	
	95	10	1-282838-1	
	85	9	1-282838-0	
	75	8	282838-9	
	65	7	282838-8	
	SEE PAGE 2	25	3	282838-7
		55	6	282838-6
		45	5	282838-5
	35	4	282838-4	
	25	3	282838-3	
	15	2	282838-2	

RECOMMENDED PC BOARD LAYOUT

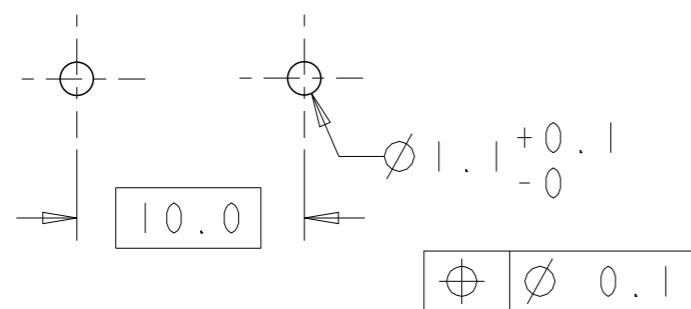

THIS DRAWING IS A CONTROLLED DOCUMENT.	
DIMENSIONS: mm	TOLERANCES UNLESS OTHERWISE SPECIFIED:
	0 PLC ±.3
	1 PLC ±.3
	2 PLC ±.25
	3 PLC ±.
	4 PLC ±.
	ANGLES ±2
MATERIAL	FINISH

DWN	24AUG2001
E. ZANOLINI	
CHK	24AUG2001
D. BIEVENOUR	
APVD	24AUG2001
D. BIEVENOUR	
PRODUCT SPEC	108-20166
APPLICATION SPEC	114-20079
WEIGHT	-
CUSTOMER DRAWING	

TE Connectivity		NAME	
		TERMINAL BLOCK PCB MOUNT SIDE ENTRY WIRE 10mm PITCH	
SIZE	CAGE CODE	DRAWING NO	RESTRICTED TO
A3	00779	C-282838	-
SCALE		SHEET	REV
4:1		1 OF 2	E

4

3

2

1

THIS DRAWING IS UNPUBLISHED.

RELEASED FOR PUBLICATION

20

© COPYRIGHT 20

BY -

ALL RIGHTS RESERVED.

REVISIONS

P	LTR	DESCRIPTION	DATE	DWN	APVD
	-	SEE SHEET 1	-	-	-

NOTES:

1. MATERIALS AND FINISH
 HOUSING : PA 6-6, UL 94-V0, COLOR GREEN.
 CLAMP : BRASS, NICKEL PLATED.
 TERMINAL : BRASS, TIN PLATED.
 CLAMPING SCREW : M3, BRASS, NICKEL PLATED.

2. MECHANICAL
 WIRE STRIPPING LENGTH : 5.0 - 6.0 mm
 MIN. PC BOARD HOLES DIAMETER : 1.1 mm
 MAX. PC BOARD THICKNESS : 2.4 mm
 RECOMMENDED TIGHTENING TORQUE FOR SCREW : 0.5 Nm.

3. ELECTRICAL
 WIRE RANGE : 16-30 AWG.
 MAX. VOLTAGE : 600 V
 MAX CURRENT : 13.5 A
 CONTACT RESISTANCE : <15 m Ohm
 INSULATION RESISTANCE : >1000 M Ohm (500V DC)

4. OPERATING TEMPERATURE RANGE : -40°C TO +110°C

5. RECOGNIZED UNDER THE COMPONENT PROGRAM OF
 UNDERWRITERS LABORATORIES INC. FILE NO E60677.

6. NOT CUMULATIVE TOLERANCE.

7. INK MARKING COLOR WHITE, UNLESS OTHERWISE SPECIFIED.
 NUMERICAL SEQUENCE : FROM LEFT TO RIGHT, UNLESS
 OTHERWISE SPECIFIED.

8. PACKED IN TRAY.

282838-7 AS SHOWN

THIS DRAWING IS A CONTROLLED DOCUMENT.		DWN E. ZANOLINI 24AUG2001	 TE Connectivity	
DIMENSIONS: mm		CHK D. BIEVENOUR 24AUG2001		
TOLERANCES UNLESS OTHERWISE SPECIFIED:		APVD D. BIEVENOUR 24AUG2001	NAME TERMINAL BLOCK PCB MOUNT SIDE ENTRY WIRE 10mm PITCH	
0 PLC ±-		PRODUCT SPEC 108-20166	RESTRICTED TO	
1 PLC ±.3		APPLICATION SPEC 114-20079	SIZE A3	CAGE CODE 00779
2 PLC ±.25		WEIGHT -	DRAWING NO C-282838	REV E
3 PLC ±-		CUSTOMER DRAWING	SCALE 4:1	SHEET 2 OF 2
4 PLC ±-				
ANGLES ±2				
MATERIAL				
FINISH				

1470-19 (3/13)