

# 承认书



## SPECIFICATION FOR APPROVAL Switching power Supply/开关电源

客 户:

CUSTOMER: SparkFun

产品描述:

DESCRIPTION: Input:100~240V AC 50/60Hz Output: 12VDC0.6A

机种型号:

OUR MODEL NO: YNQX09L120060UL

样品编号:

日期:

SAMPLE NO: QX201800213

DATE: 2018-03-08

产品颜色:

SAMPLE COLOR: Black  White

符合环保项: ROHS  REACH  PAHS  17P  加州 65

APPROVAL SIGNATURE/客户确认		
核准/APPROVED BY	审核/CHECKED BY	检测/TESTED BY
Manufacturer/制造商		
业务/SALES	核准/APPROVED BY	设计/DESIGNED BY
Nick Lin		

深圳市齐鑫电子有限公司

SHEN ZHEN QI XIN ELECTRONICS CO.,LTD

地址: 中国广东省深圳市宝安区福永镇重庆路新福工业园 A6 栋 3 楼

Add: Floor3, Buiding A6, Xinfu Industrial Zone, Chongqing Road, Fuyong Town,  
Baoan District, Shenzhen, China.

Tel: 0755-29609342 81443738 Fax: 0755-29776652

<http://www.qshain.com.cn> E-mail: [nick@qshain.com.cn](mailto:nick@qshain.com.cn)

深圳市齐鑫电子有限公司  
SHEN ZHEN QI XIN ELECTRONICS CO., LTD

型号/Our model: YNQX09L120060UL

客户/Customer: SparkFun

日期/Date:2018-03-08

样品编号/SAMPLE No: QX201800213

版本目录/Rev. List

版本/Rev.	日期/Date	描述/Description	制订/Design
A0	2018-03-08	新版本/New Rev.	CM

Table of contents

1、描述/DESCRIPTION.....3

2、输入特性/INPUT CHARACTERISTICS.....3

3、输出特性/OUTPUT CHARACTERISTICS..... 4

4、保护功能/PROTECTION FUNCTION..... 5

5、环境要求/ENVIRONMENTAL REQUIREMET.....5~6

6、安全及 EMC 要求/SAFETY AND EMC REQUIREMENT..... 6

7、结构参数/MECHANICAL REQUIREMENT.....7

8、线材/CORD.....8

9、铭牌附图/LABEL.....9

10、包装说明/PACKING.....10

11、测试报告/ELECTRICAL TEST REPORT..... 11

深圳市齐鑫电子有限公司  
SHEN ZHEN QI XIN ELECTRONICS CO., LTD

型号/Our model: YNQX09L120060UL

客户/Customer: SparkFun

日期/Date:2018-03-08

样品编号/SAMPLE No: QX201800213

## 1、描述/ DESCRIPTION:

本规格书适应于 YNQX09L120060UL 型号的开关电源.

The purpose of the document is to specify the functional requirements of a 7.2W switching power supply.

## 2、输入特性/INPUT CHARACTERISTICS:

### 2.1 输入电压/Input Voltage:

额定电压/Rated Voltage:100~240Vac

调整范围/Variation Range:90-264Vac

### 2.2 输入频率/Input Frequency:

额定频率/ Rated Frequency: 50/60Hz.

调整频率/Variation Frequency:47-63Hz

### 2.3 输入电流/Input Current:

当输入交流电压为额定值的下限电压负载满载时,最大输入交流电流 0.3A.

0.3Amps max At any input voltage and rated, DC output rated load.

### 2.4 浪涌电流/Inrush Current:

当输出为额定负载,环境温度为 25℃,输入 240Vac 冷态起机时将不会损坏.

No damage shall be occurred and the input fuse shall not be blown up, Cold start at 240Vac input, with rated load and 25℃ ambient.

### 2.5AC 漏电流/Ac Leakage Current:

当输入电压 240Vac 时,最大漏电流为 0.25mA.

0.25mA Max.At240Vac input.

深圳市齐鑫电子有限公司  
SHEN ZHEN QI XIN ELECTRONICS CO., LTD

型号/Our model: YNQX09L120060UL

客户/Customer: SparkFun

日期/Date:2018-03-08

样品编号/SAMPLE No: QX201800213

### 3、输出特性/OUTPUT CHARACTERISTICS:

#### 3.1 输出功率/Power output (AC:100~240V)

电压 Voltage	最小负载 Min. Load	额定负载 Rated. Load	峰值功率 Peak	输出功率 Output power
12VDC	0.01A	0.6A		7.2W

#### 3.2 负载特性,调整率/Combined Load/Line Regulation (AC:100~240V)

电压 Voltage	最小负载 Min. Load	额定负载 Rated. Load	线性调整 Line Regulation	负载调整 Load Regulation
12VDC	0.01A	0.6A	±2%	±5%

#### 3.3 纹波和噪音 Ripple and Noise:

测试条件:在输入 115/230Vac 25°C和输出最小及最大负载时,使用示波器带宽为 20MHz 连接到适配器的输出端,同时输出端并联一个 47uF 的电解电容和一个 0.1uF 的瓷片电容.

At 115/230Vac 25°C input and output Min and Max.Load,the ripple and noise are as follows when measure with Max.Bandwidth of 20MHz and Parallel 47uF/0.1uF,crossed connected at testing point.

电压 Voltage	最大纹波/最大噪音 Ripple and Noise(Max.)
+12VDC	200mV p-p

#### 3.4 启动延迟时间/Turn on delay time:

当输入 115Vac 和输出最大负载时,最大启动时间为 3S.

3Second Max.at 115Vac input and output Max.load.

#### 3.5 上升时间/Rise time:

当输入 115Vac 和输出最大负载时最大时间为 40 mS.

40 mS Max.at 115Vac input and output Max load.

#### 3.6 保持时间/Hold up time:

当输入 115Vac 和输出最大负载时,最小保持时间为 5 mS .

5 mS Min.at 115Vac input and output Max.Load.

#### 3.7 过冲/Overshoot:

在电源开启或关闭的时候,最大 15%.

15% Max.When power supply at turn or turn off.

#### 3.8 效率/Efficiency:

当 115/230Vac 输入电压时, 1/4, 1/2, 3/4 和满载计算平均效率, 最小 80.01%.

80.01% Min,At 115/230Vac input voltage,1/4, 1/2, 3/4 and full load calculation average efficiency.

适配器满足能效 VI.

Adapter meet efficiency level VI.

深圳市齐鑫电子有限公司  
SHEN ZHEN QI XIN ELECTRONICS CO., LTD

型号/Our model: YNQX09L120060UL

客户/Customer: SparkFun

日期/Date:2018-03-08

样品编号/SAMPLE No: QX201800213

### 3.9 待机功耗/Standby Power:

当输入 115Vac 60Hz 时 0.1W 最大 .

0.1W Max. at 115Vac 60Hz Io=0 input.

### 4、保护功能/PROTECTION FUNCTION:

#### 4.1 短路电路保护/Short circuit protection:

该电源供给器在短路解除时能正常工作恢复.

The power supply will be auto recovered when short circuit faults remove.

#### 4.2 过流保护/Over current Protection:

过流故障排除后,电源将自动恢复正常工作.

The power supply will be auto recovered when over current faults remove.

### 5、环境要求/ENVIRONMENTAL REQUIREMET:

#### 5.1 工作温度/Operating Temperature:

0°C-40°C,满载,正常工作.

0°C to 40°C,Full load, Normal operation.

#### 5.2 储藏温度/Storage Temperature:-20°C to 60°C

带外壳/With package

#### 5.3 工作湿度/Relative Humidity:

5%(0°C)~90%(40°C),72 小时,满载,正常工作.

5%(0°C)~90%(40°C)RH,72Hrs,Full load, Normal operating.

#### 5.4 振动/Vibration:

##### 1. 测试标准:国际电工电子委员会

Operating: IEC 721-3-3 3M3

5~9Hz,A=1.5mm

加速度(9~200Hz,Acceleration 5m/S2)

##### 2. 运输/Transportation:

IEC 721-3-2 2M2

5-9Hz,A=3.5mm

9~200Hz,加速度 Acceleration=5m/S2

200~500Hz,加速度 Acceleration=15m/S2

##### 3. 轴向振动/Axes,10 cycles per axis.

在测试过程中不能出现永久性的损坏.

No permanent damage may occur during testing.

在电源开启和关闭后,样机能够恢复到最初条件.

The SAMPLE has to restore to its original situation after power off/on..

深圳市齐鑫电子有限公司  
SHEN ZHEN QI XIN ELECTRONICS CO., LTD

型号/Our model: YNQX09L120060UL

客户/Customer: SparkFun

日期/Date:2018-03-08

样品编号/SAMPLE No: QX201800213

**5.5 跌落试验/Dropping Packed:**

跌落高度为 1000mm;

Drop the height is 1000mm.

测试台面是厚 13mm 的夹木板, 离地面高 19-20mm

The horizontal surface Consists of hardwood at least 13mm thick,mounted on two layers of plywood each 19mm to 20mm thick,all supported on a concrete or equivalent non-resilient floor.

**6、安全及 EMC 要求/SAFETY AND EMC REQUIREMENT:**

**6.1 安全: 符合标准 UL60950**

Safety:accord standard with UL60950

**6.2 高压/DIELECTRIC STRENGTH Hi-Pot:**

初级对次级/Primary to secondary: 4242Vdc/5mA/60S for type test.

**6.3 绝缘阻抗/Insulation resistance:**

初级对次级/Primary to secondary:20M $\Omega$  min at 500V DC.

**6.4 EMI 标准/EMI STANDARD**

Meets the Limits of/测试符合

<1>.Fcc part15 class B rules

<2>.EN55032 class B rules

<3>. GB17625.1-2012

<4>.AS/NZS CISPR32:2015.

<5>.IEC61000-4-5

<6>.IEC61000-4-2

深圳市齐鑫电子有限公司  
SHEN ZHEN QI XIN ELECTRONICS CO., LTD

型号/Our model: YNQX09L120060UL

客户/Customer: SparkFun

日期/Date: 2018-03-08

样品编号/SAMPLE No: QX201800213

7、结构参数/MECHANICAL REQUIREMENT:

7.1 外壳/Enclosure:

外壳尺寸: L67 x W24 x H37.5mm;

The power supply size: L67x W24 x H37.5mm;

7.2 输入线/Input Connector:

2 Pin US 插脚/Two pin input plug of US.

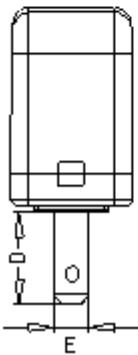
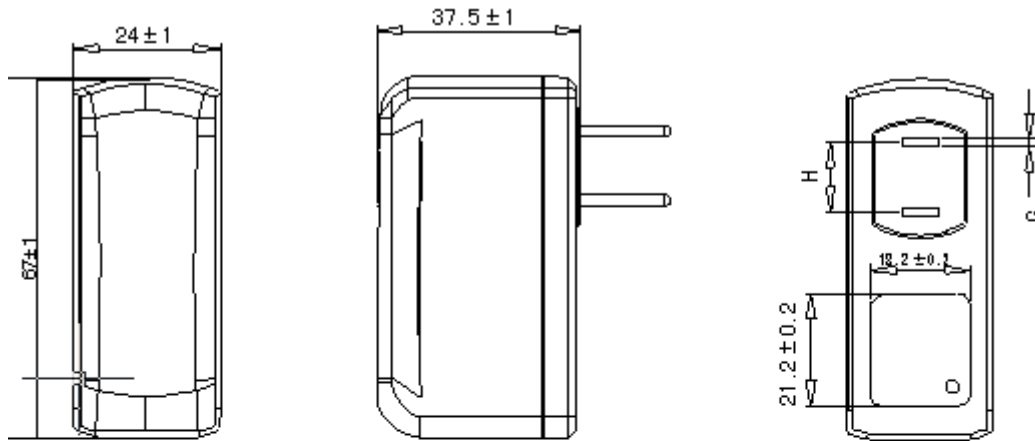

符号 / No.	公差值/Standard deviation (mm)
D	16-18 (1.7)
E	6.09-6.60 (6.35)
G	1.40-1.65 (1.50)
H	12.6-12.8 (12.7)

深圳市齐鑫电子有限公司  
SHEN ZHEN QI XIN ELECTRONICS CO., LTD

型号/Our model: YNQX09L120060UL

客户/Customer: SparkFun

日期/Date: 2018-03-08

样品编号/SAMPLE No: QX201800213

8、线材/CORD:

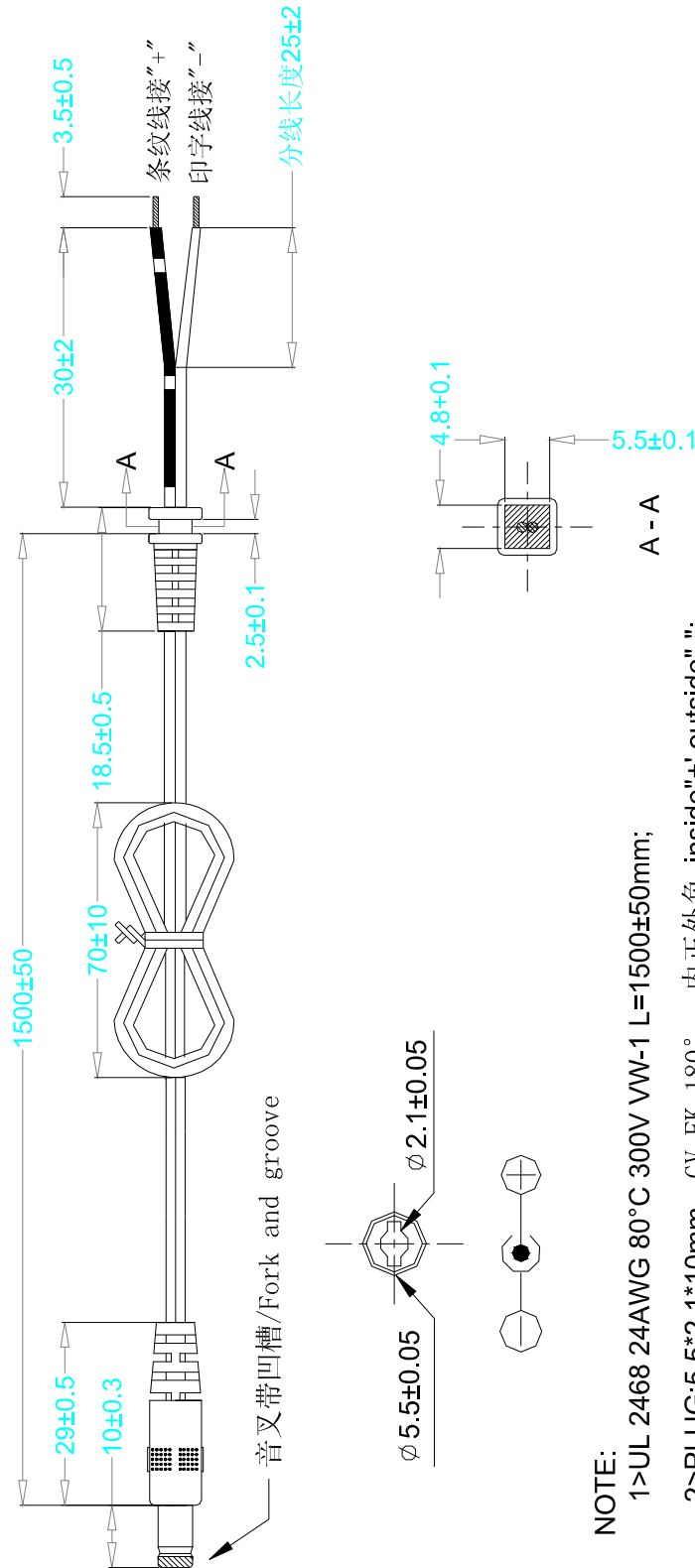

- NOTE:
- 1>UL 2468 24AWG 80°C 300V VW-1 L=1500±50mm;
  - 2>PLUG:5.5\*2.1\*10mm, GV FK 180°, 内正外负, inside"+", outside"-";
  - 3>Color:Black;
  - 4>RoHS2.0REACH(PAHS\17P\加州65.
  - 5>Material:线皮: PVC.线芯: 铜.



深圳市齐鑫电子有限公司  
SHEN ZHEN QI XIN ELECTRONICS CO., LTD

型号/Our model: YNQX09L120060UL

客户/Customer: SparkFun

日期/Date:2018-03-08

样品编号/SAMPLE No: QX201800213

9、铭牌/LABEL:

17.90 mm

**QSHAIN™** AC Adapter  
MODEL:YNQX09L120060UL  
INPUT:100-240V ~50/60Hz 0.3A  
OUTPUT:12V  $\equiv$  0.6A  $\ominus$ — $\bullet$ — $\oplus$   
EFFICIENCY LEVEL:  $\textcircled{\text{VI}}$  115  
I.T.E POWER SUPPLY YYWW

 This device complies with Part 15 of the FCC Rules.Operation is subject to the following two conditions:  
(1)this device may not cause harmful interference,and  
(2)this device must accept any interference received,including interference that may cause undesired operation

Tested To Comply  
With FCC Standards  
FOR HOME OR OFFICE USE  
CAN ICES-3(B) /NMB-3(B) 

MADE IN CHINA

21.00 mm



NOTE:

- 1.颜色/Color:黑底白字/ Black ground white
- 2.材质/Material:PET+雾面/fog surface
- 3.厚度/Thickness:0.25mm
- 4.误差/Toilerance:+0/-0.2mm
- 5.环保/RoHS
- 6.YYWW,YY 表示年份,WW 表示周数
- 7.此铭牌是按业务要求制作

深圳市齐鑫电子有限公司  
SHEN ZHEN QI XIN ELECTRONICS CO., LTD

型号/Our model: YNQX09L120060UL

客户/Customer: SparkFun

日期/Date: 2018-03-08

样品编号/SAMPLE No: QX201800213

10、包装说明/PACKING:

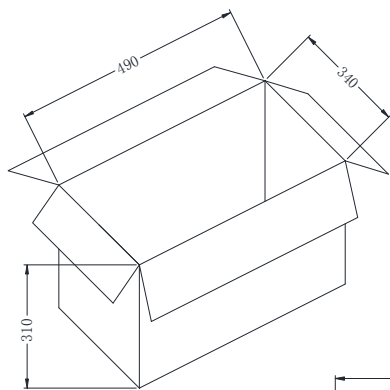

外箱/Carton

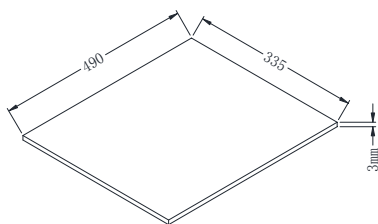

平板/Slab

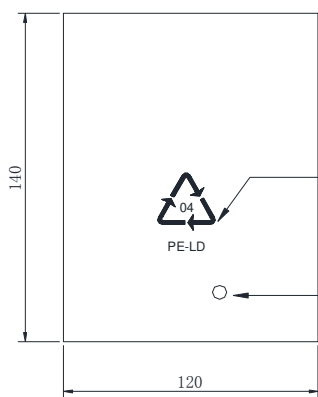
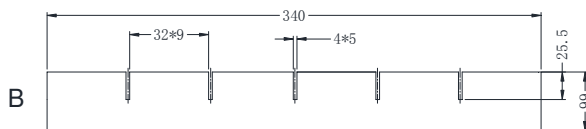
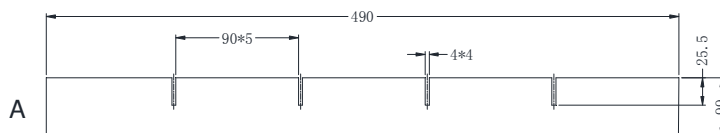

胶袋/Pe bag

绿色字体/  
Green lettering

透气孔  
Breathe freely os

包材/Packing:

A:L490\*W99mm

B:L340\*W99mm

外箱内尺寸/Carton inside size :L490\*W340\*H310mm

平板/Slab:L490\*W335\*T3mm

胶袋/Pe bag:L140\*W120\*T0.03mm

数量/Quantity:135PCS/CTN

备注：此包装材料仅供参考。

深圳市齐鑫电子有限公司  
SHEN ZHEN QI XIN ELECTRONICS CO., LTD

型号/Our model: YNQX09L120060UL

客户/Customer: SparkFun

日期/Date:2018-03-08

样品编号/SAMPLE No: QX201800213

11、测试报告/ELECTRICAL TEST REPORT:

No 序号	Test item 测试项目	Test condition 测试条件	Standard spec 标准规格	Test data 测试数据					Unit 单位	Judge 判定
				1	2	3	4	5		
1	Output Voltage 输出电压	Vin100Vac 60Hz Io=0 输入 100Vac 空载	12Vdc±5%	11.98	11.95				V	Pass
2	Output Voltage 输出电压	Vin100Vac 60HzIo=Rated Current 输入 100Vac 60Hz 负载	12Vdc±5%	11.80	11.81				V	Pass
3	Average Efficiency 平均效率	Vin 115Vac 60Hz 输入 115Vac 60Hz	80.01%	80.58	80.63				%	Pass
4	Ripple&Noise mVp-p 纹波&杂讯	Vin100Vac 60Hz Full load 输入 100Vac 60Hz 满载	200mVp-p	113	113				mVp-p	Pass
5	Line Regulation 线性调整率	Vin=100V~240V Io=Rated Current 额定电流	±2%	OK	OK				/	Pass
6	Standby Power 待机功耗	Vin 115Vac 60Hz Io=0 输入 115Vac 60Hz	0.1W max	0.05	0.05				W	Pass
7	Short circuit test 短路测试	Vin100Vac 60Hz 输入 100Vac 空载	No odor smoke fire plastic deformation and excessive heat happen. 无冒烟,起火,外壳变 形及过热现象	OK	OK				/	Pass
8	OCP 过电流保护	Vin100Vac 60Hz 输入 100Vac	AMax	1.06	1.06				A	
9	Output Voltage 输出电压		12Vdc±5%	11.98	11.95				V	Pass
10	Output Voltage 输出电压	Vin240Vac 50HzIo=Rated Current 输入 240Vac 60Hz 负载	12Vdc±5%	11.80	11.81				V	Pass
11	Average Efficiency 平均效率	Vin230Vac 50Hz 输入 230Vac 50Hz	80.01%	80.67	80.72				%	Pass
12	Ripple & Noise mVp-p 纹波&杂讯	Vin240Vac 50Hz Full load 输入 240Vac 50Hz 额定电流	200mVp-p	112	112				mVp-p	Pass
13	Line Regulation 线性调整率	Vin=100V~240V Io=Rated Current 输入 100V~240V	±2%	OK	OK				/	Pass
14	Standby Power 待机功耗	Vin230Vac 50Hz Io=0 输入 230V 50Hz	/	/	/				W	Pass
15	Short circuit test 短路测试	Vin240Vac 50Hz 输入 240Vac 50Hz	No odor smoke fire plastic deformation and excessive heat happen. 无冒烟,起火,外壳变 形及过热现象	OK	OK				/	Pass
16	OCP 过电流保护	Vin230Vac 50Hz 输入 230Vac 50Hz	AMax	1.04	1.04				A	
17	Hi-pot test 高压测试	高压/DIELECTRIC STRENGTH Hi-Pot 初级对次级 /Primary to secondary:4242Vdc/5mA/60S for type test		OK	OK				/	Pass
18	Burn in 老化	Input:220Vac/50Hz Full Load 4hrs 输入 220Vac/50Hz 满载 4 小时		OK	OK				/	Pass
19	Drop test 跌落	Heigh: 1m Three*faces(once on each plane) 高 1 米,3 个面,每面 1 次.		OK	OK				/	Pass
REMARK 备注										