

DESCRIPTION: **HIGH DENSITY DIP SOLDER MALE**

POS.	A	B	C	D	E	F	G
15	1.213	0.984	0.666	0.756	0.329	0.090	0.496
	30.80	24.99	16.92	19.20	8.36	2.29	12.60
26	1.543	1.312	0.994	1.091	0.329	0.090	0.496
	39.19	33.32	25.25	27.70	8.36	2.29	12.60
44	2.087	1.852	1.534	1.618	0.329	0.090	0.496
	53.00	47.04	38.96	41.10	8.36	2.29	12.60
62	2.732	2.500	2.181	2.256	0.329	0.095	0.496
	69.30	63.50	55.42	57.30	8.36	2.41	12.60
78	2.638	2.406	2.079	2.169	0.445	0.095	0.606
	67.00	61.00	52.80	55.10	11.30	2.41	15.39

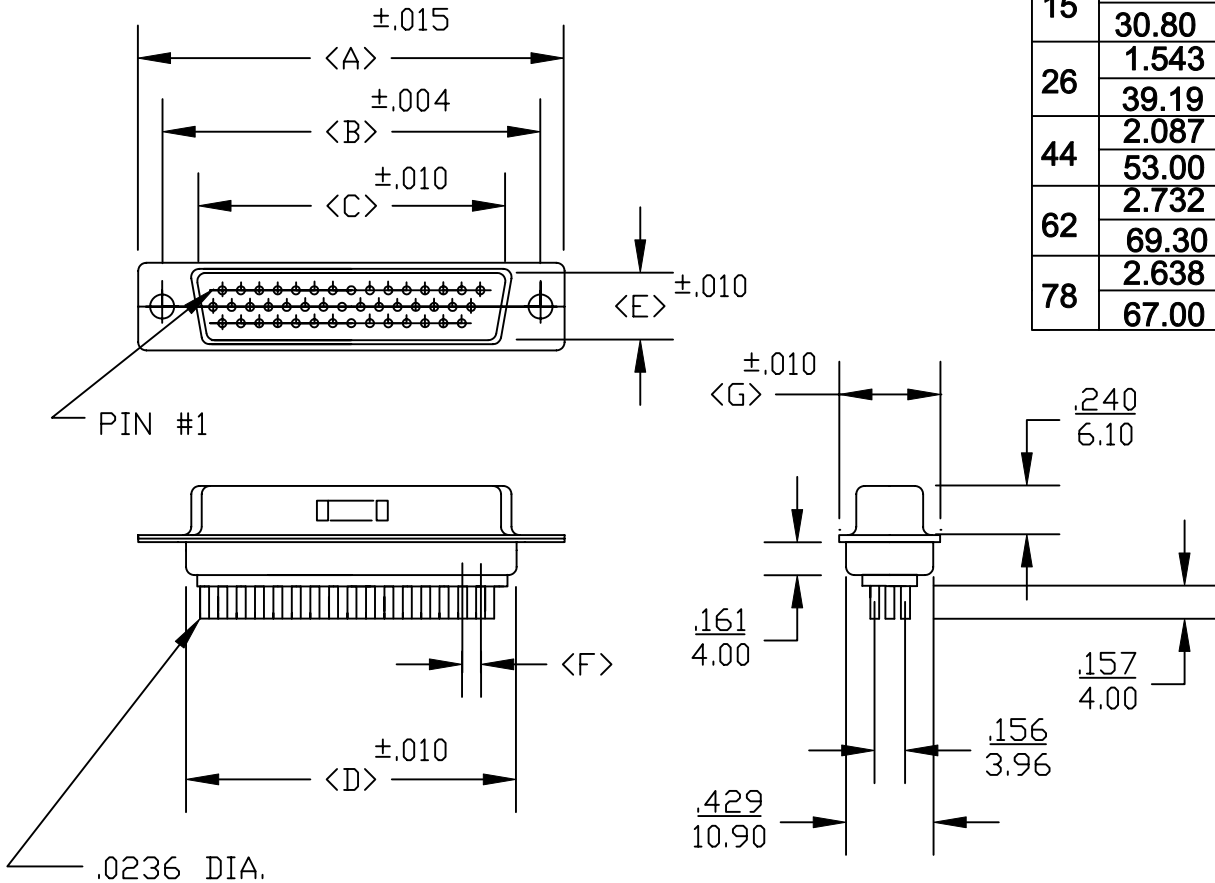

180-XXX-112-XX1

SERIES _____
 POSITIONS _____
 015
 026
 044
 062
 078
 GENDER _____
 1 = MALE
 2 = FEMALE
 TERMINATION _____
 1 = VERTICAL DIP SOLDER
 SHELL PLATING _____
 2 = TIN
 HARDWARE OPTIONS _____
 00 = NO HARDWARE
 01 = .098 4-40 CLINCH NUT BOARD SIDE
 02 = .250 4-40 CLINCH NUT BOARD SIDE
 03 = .250 4-40 CLINCH NUT MATING SIDE
 90 = .225 4-40 SPACER/BOARD LOCK
 PLATING OPTIONS _____
 1 = GOLD FLASH

SPECIFICATIONS:

MATERIALS:

SHELL: STEEL, TIN PLATED
 INSULATOR: UL 94V-0 RATED BLACK
 GLASS-FILLED POLYESTER

ELECTRICALS:

CURRENT RATING: 2 AMPS
 CONTACT RESISTANCE: 15 mOHMS MAX
 INSULATOR RESISTANCE: 1000 MOHMS MIN
 VOLTAGE: 500V AC FOR 1 MINUTE
 TEMPERATURE: -50°C TO +100°C

	THESE DRAWINGS AND SPECIFICATIONS ARE THE PROPERTY OF NorComp AND SHALL NOT BE REPRODUCED, COPIED OR USED AS THE BASIS FOR THE MANUFACTURE OR SALE OF APPARATUS WITHOUT WRITTEN PERMISSION.		DRAWN: PAM JENKINS	DATE: 8-12-98
	<h1>NorComp</h1>			CHECKED:
SCALE:				SHEET OF
			DWG NO. 180-XXX-112-XX1	

DESCRIPTION: CLINCH NUT HARDWARE

ALL CLINCH-NUTS ARE 4-40 INTERNAL THREADS

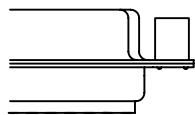

03X..... .250" (MATING SIDE) - CN8

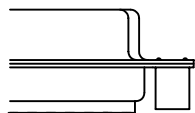

02X250" (BOARD SIDE) - CN2

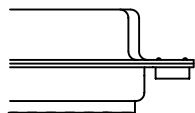

01X098" (BOARD SIDE) - CN1

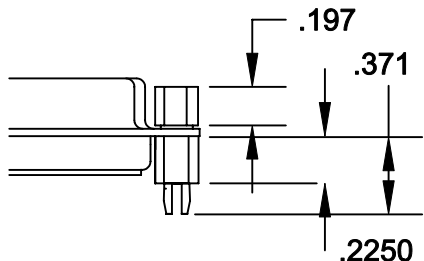

91X225" (BOARD SIDE) - .197 MATING SIDE - CN10/SFS0440
 NOTE: 4-40 FEMALE SCREW LOCK IS REMOVABLE

	THESE DRAWINGS AND SPECIFICATIONS ARE THE PROPERTY OF NorComp AND SHALL NOT BE REPRODUCED, COPIED OR USED AS THE BASIS FOR THE MANUFACTURE OF SALE OF APPARATUS WITHOUT WRITTEN PERMISSION.		DRAWN: WAYNE ROBBINS	DATE: 8-23-98
	NorComp		CHECKED: PAM JENKINS	DATE: 8-24-98
SCALE:			SHEET 1 OF 1	REV 1
DWG NO.			CLINCH-NUT OPTIONS	

DESCRIPTION: HIGH DENSITY DIP SOLDER MALE FOOTPRINT

78 POSITION MALE

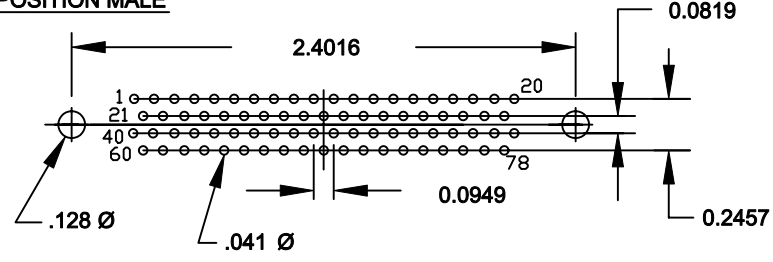

26 POSITION MALE

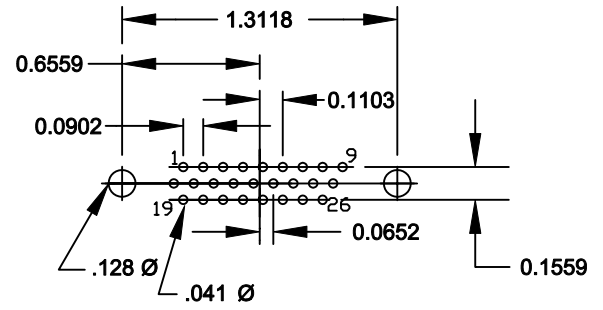

62 POSITION MALE

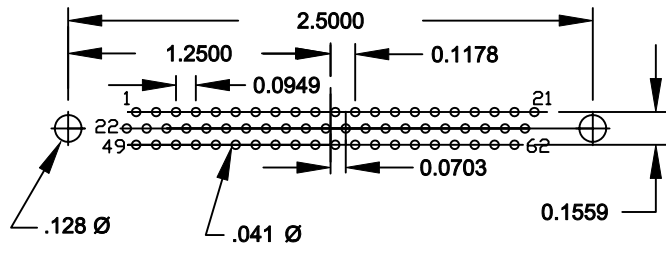

15 POSITION MALE

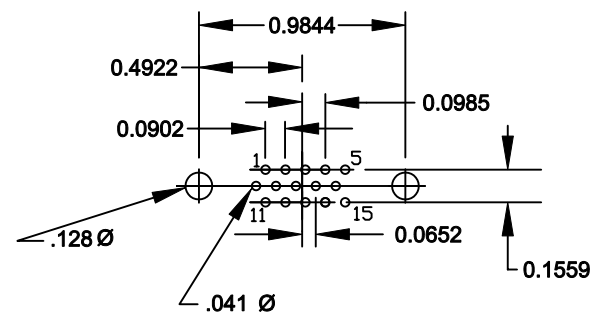

44 POSITION MALE

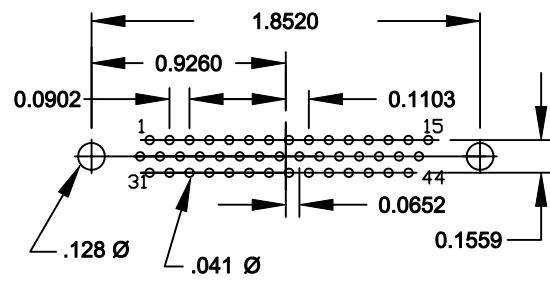

	THESE DRAWINGS AND SPECIFICATIONS ARE THE PROPERTY OF NorComp AND SHALL NOT BE REPRODUCED, COPIED OR USED AS THE BASIS FOR THE MANUFACTURE OF SALE OF APPARATUS WITHOUT WRITTEN PERMISSION.		DRAWN: PAM JENKINS	DATE: 10-29-01
			CHECKED:	DATE:
<h1>NorComp</h1>		SCALE:	SHEET 1 OF 1	REV 2
		DWG NO. HIGH DENSITY VERTICAL MALE FOOTPRINT		