

IO-Link master evaluation board based on L6360 equipped with ST morpho connectors for STM32 Nucleo



Features

- IO-Link master PHY based on L6360
- Interrupt diagnostics pin
- I²C and UART interface
- SPI (slave) interface
- 65 mA selectable (3.3 or 5.0 V) linear regulator
- CQ (push-pull) and L+ (high side) switches
- IQ additional IEC61131-2 type 1 digital input
- L+ and CQ overload and overheating protections with non-dissipative cut-off function
- QFN-26L (3.5x5x1 mm) package
- Operating voltage range from 18 to 32.5 V
- Additional high side switch for L+ heavy loads (IPS161H)
- LEDs for status and diagnostics
- Ground and V_{CC} wire break protections
- EMC compliance with IEC61000-4-2, IEC61000-4-3, IEC61000-4-5
- Equipped with ST morpho connectors
- CE certified
- RoHS and China RoHS compliant

Description

The STEVAL-IOM001V1 evaluation board is based on the L6360 IO-Link master transceiver with physical layer compliant with IO-Link v1.1 specification.

Together with the STSW-IOM001 example code, it provides an affordable and easy-to-use solution for the development of user applications, letting you easily evaluate the communication features and robustness of the L6360.

You can also perform evaluation of multiple ports industrial IO-Link master modules by connecting up to four STEVAL-IOM001V1 with few solder bridge modifications.

The STEVAL-IOM001V1 interfaces with the STM32 Nucleo microcontroller via UART and GPIO pins and is compatible with the Arduino UNO R3 (optional configuration) and ST morpho (default configuration) connectors.

Product summary	
IO-Link master evaluation board based on L6360 equipped with ST morpho connectors for STM32 Nucleo	STEVAL-IOM001V1
IO-Link communication master transceiver IC	L6360
L6360 IO-Link communication transceiver master IC evaluation software based on STM32Cube	STSW-IOM001
Applications	Factory Automation

Figure 2. STEVAL-IOM001V1 circuit schematic (2 of 4): Arduino connectors

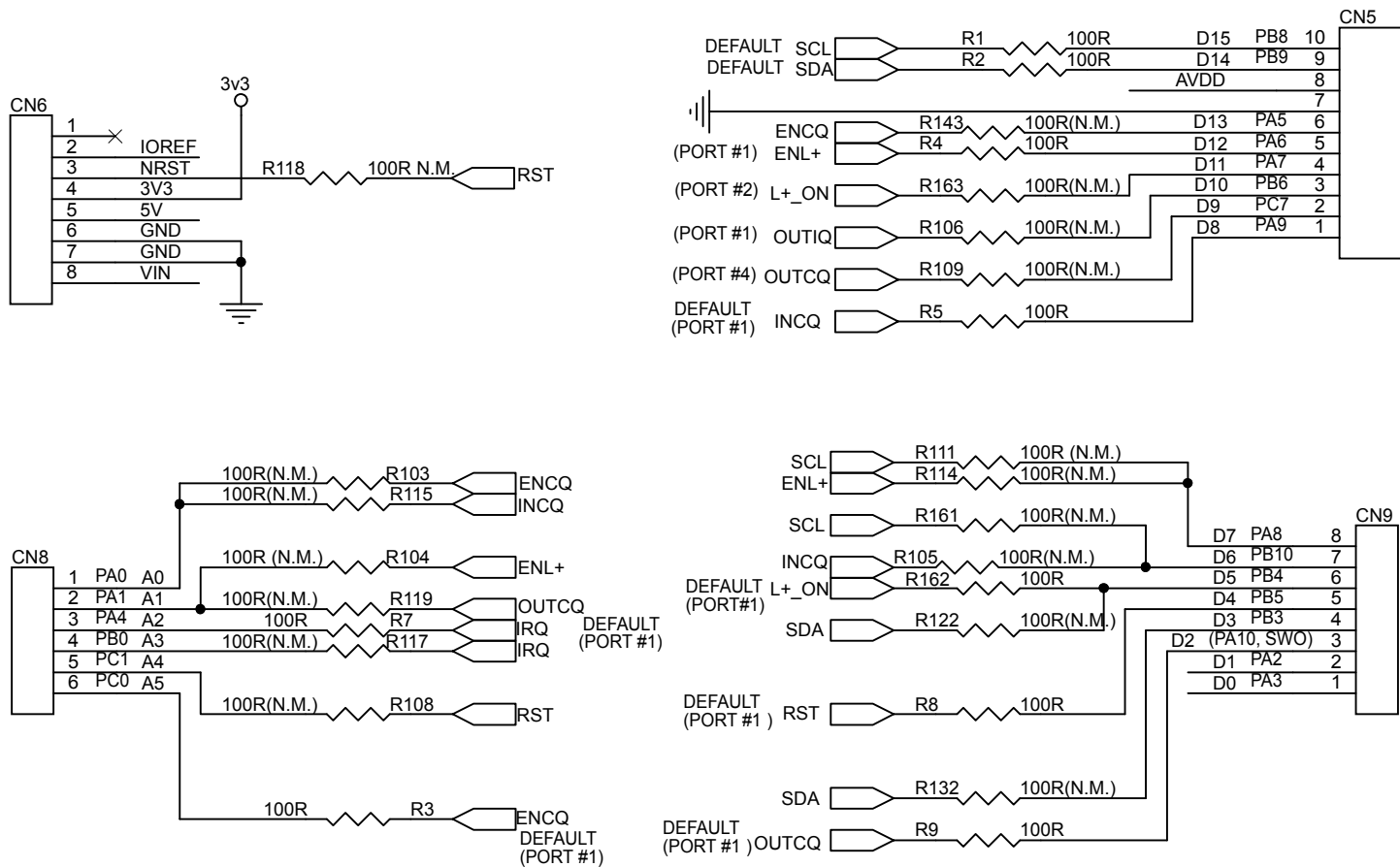

Figure 3. STEVAL-IOM001V1 circuit schematic (3 of 4): ST morpho connectors

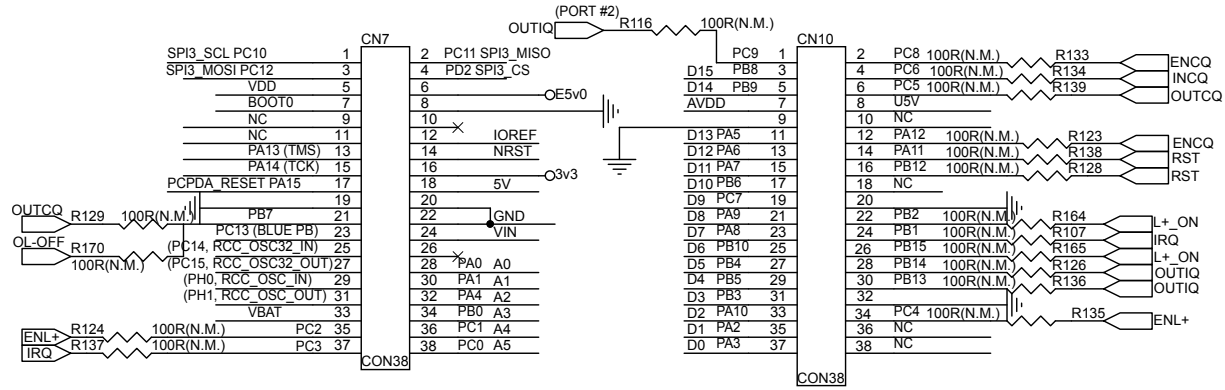
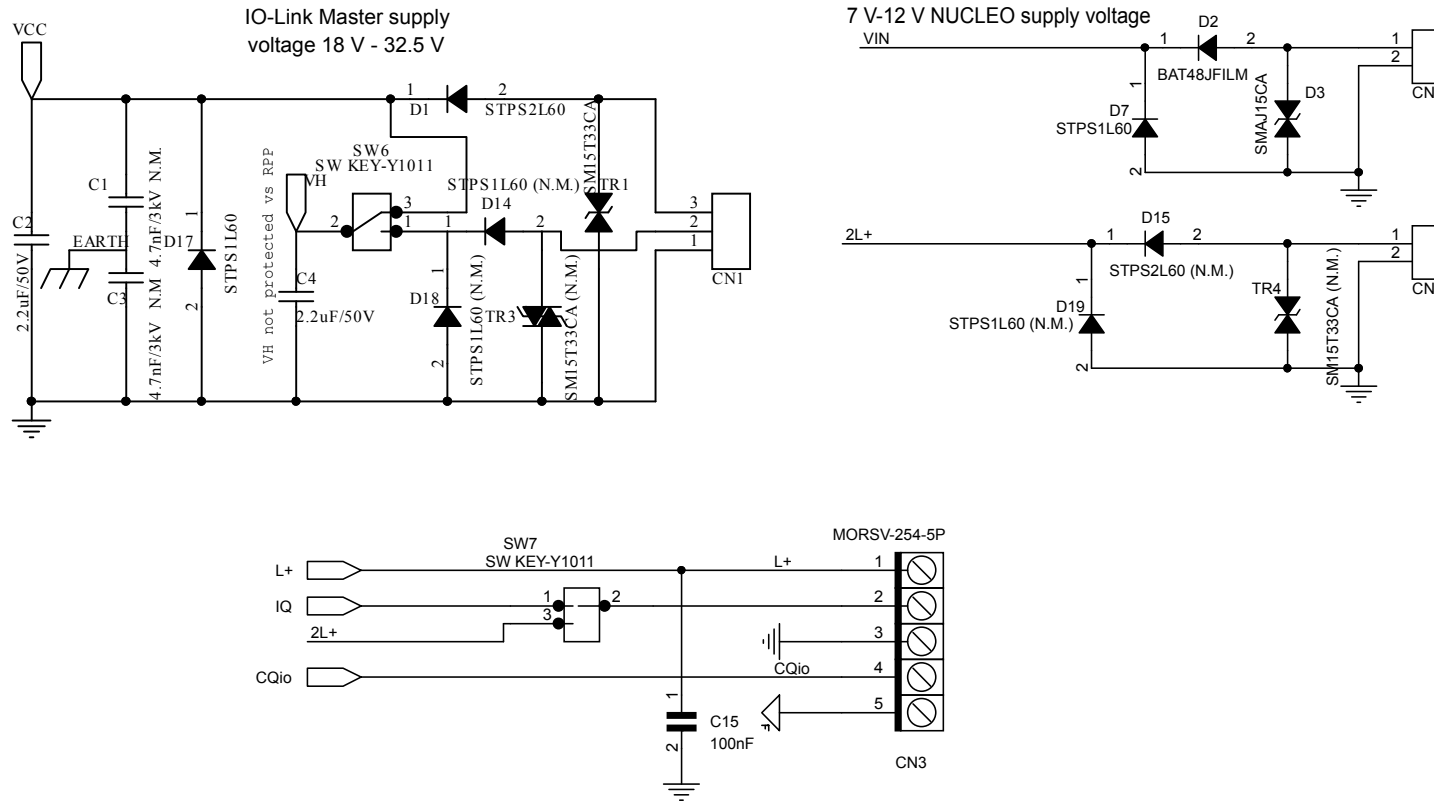

Figure 4. STEVAL-IOM001V1 circuit schematic (4 of 4): supply voltage



Revision history

Table 1. Document revision history

Date	Version	Changes
15-Jun-2018	1	Initial release.
23-Apr-2021	2	Updated Section 1 STEVAL-IOM001V1 schematic diagrams.

IMPORTANT NOTICE – PLEASE READ CAREFULLY

STMicroelectronics NV and its subsidiaries (“ST”) reserve the right to make changes, corrections, enhancements, modifications, and improvements to ST products and/or to this document at any time without notice. Purchasers should obtain the latest relevant information on ST products before placing orders. ST products are sold pursuant to ST’s terms and conditions of sale in place at the time of order acknowledgement.

Purchasers are solely responsible for the choice, selection, and use of ST products and ST assumes no liability for application assistance or the design of Purchasers’ products.

No license, express or implied, to any intellectual property right is granted by ST herein.

Resale of ST products with provisions different from the information set forth herein shall void any warranty granted by ST for such product.

ST and the ST logo are trademarks of ST. For additional information about ST trademarks, please refer to www.st.com/trademarks. All other product or service names are the property of their respective owners.

Information in this document supersedes and replaces information previously supplied in any prior versions of this document.

© 2021 STMicroelectronics – All rights reserved