

I²C-PROGRAMMABLE ANY-FREQUENCY CMOS CLOCK GENERATOR + VCXO

Features

- Generates up to 8 non-integer-related frequencies from 8 kHz to 160 MHz
- I²C user definable configuration
- Exact frequency synthesis at each output (0 ppm error)
- Highly linear VCXO
- Optional clock input (CLKIN)
- Low output period jitter: 100 ps pp
- Configurable spread spectrum selectable at each output
- Operates from a low-cost, fixed frequency crystal: 25 or 27 MHz
- Supports static phase offset
- Programmable rise/fall time control
- Glitchless frequency changes
- Separate voltage supply pins:
 - Core VDD: 2.5 or 3.3 V
 - Output VDDO: 1.8, 2.5, or 3.3 V
- Excellent PSRR eliminates external power supply filtering
- Very low power consumption
- Adjustable output-output delay
- Available in 3 packages types:
 - 10-MSOP: 3 outputs
 - 24-QSOP: 8 outputs
 - 20-QFN (4x4 mm): 8 outputs
- PCIE Gen 1 compliant
- Supports HCSL compatible swing

Applications

- HDTV, DVD/Blu-ray, set-top box
- Audio/video equipment, gaming
- Printers, scanners, projectors
- Residential gateways
- Networking/communication
- Servers, storage
- XO replacement

Description

The Si5351 is an I²C configurable clock generator that is ideally suited for replacing crystals, crystal oscillators, VCXOs, phase-locked loops (PLLs), and fanout buffers in cost-sensitive applications. Based on a PLL/VCXO + high resolution MultiSynth fractional divider architecture, the Si5351 can generate any frequency up to 160 MHz on each of its outputs with 0 ppm error. Three versions of the Si5351 are available to meet a wide variety of applications. The Si5351A generates up to 8 free-running clocks using an internal oscillator for replacing crystals and crystal oscillators. The Si5351B adds an internal VCXO and provides the flexibility to replace both free-running clocks and synchronous clocks. The Si5351B eliminates the need for higher cost, custom pullable crystals while providing reliable operation over a wide tuning range. The Si5351C offers the same flexibility but synchronizes to an external reference clock (CLKIN).

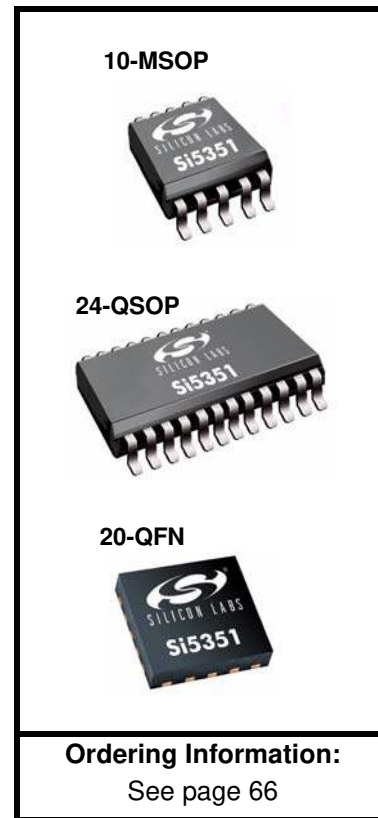

Functional Block Diagram

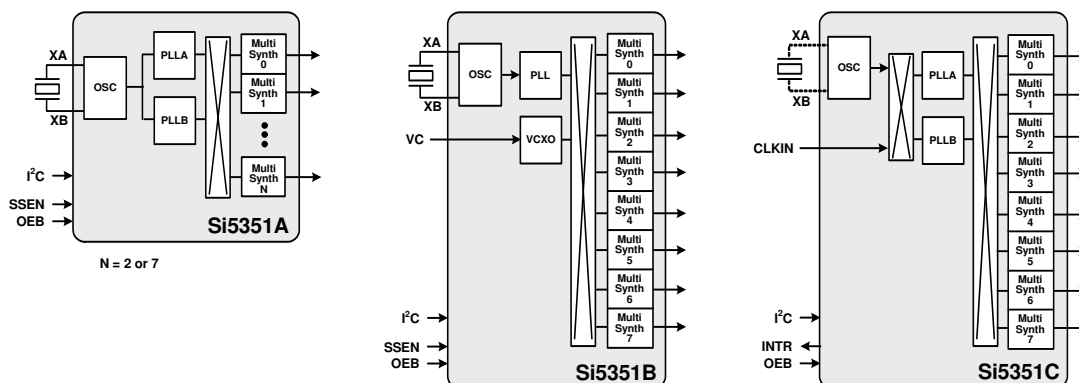

TABLE OF CONTENTS

<u>Section</u>	<u>Page</u>
1. Electrical Specifications	4
2. Detailed Block Diagrams	9
3. Functional Description	11
3.1. Input Stage	11
3.2. Synthesis Stages	12
3.3. Output Stage	12
3.4. Spread Spectrum	13
3.5. Control Pins (OEB, SSEN)	13
4. I2C Interface	14
5. Configuring the Si5351	16
5.1. Writing a Custom Configuration to RAM	16
5.2. Si5351 Application Examples	18
5.3. Replacing Crystals and Crystal Oscillators	18
5.4. Replacing Crystals, Crystal Oscillators, and VCXOs	19
5.5. Replacing Crystals, Crystal Oscillators, and PLLs	19
5.6. Replacing a Crystal with a Clock	20
5.7. HCSL Compatible Outputs	20
6. Design Considerations	21
6.1. Power Supply Decoupling/Filtering	21
6.2. Power Supply Sequencing	21
6.3. External Crystal	21
6.4. External Crystal Load Capacitors	21
6.5. Unused Pins	21
6.6. Trace Characteristics	22
7. Register Map Summary	23
8. Register Descriptions	25
9. Si5351A Pin Descriptions (20-Pin QFN, 24-Pin QSOP)	62
10. Si5351B Pin Descriptions (20-Pin QFN, 24-Pin QSOP)	63
11. Si5351C Pin Descriptions (20-Pin QFN, 24-Pin QSOP)	64
12. Si5351A Pin Descriptions (10-Pin MSOP)	65
13. Ordering Information	66
14. Package Outline (24-Pin QSOP)	67
15. Package Outline (20-Pin QFN)	68
16. Package Outline (10-Pin MSOP)	69
Document Change List	70
Contact Information	72

Si5351A/B/C

1. Electrical Specifications

Table 1. Recommended Operating Conditions

Parameter	Symbol	Test Condition	Min	Typ	Max	Unit
Ambient Temperature	T_A		-40	25	85	°C
Core Supply Voltage	V_{DD}		3.0	3.3	3.60	V
			2.25	2.5	2.75	V
Output Buffer Voltage	V_{DDOx}		1.71	1.8	1.89	V
			2.25	2.5	2.75	V
			3.0	3.3	3.60	V

Notes: All minimum and maximum specifications are guaranteed and apply across the recommended operating conditions. Typical values apply at nominal supply voltages and an operating temperature of 25 °C unless otherwise noted. VDD and VDDOx can be operated at independent voltages. Power supply sequencing for VDD and VDDOx requires that both voltage rails are powered at the same time.

Table 2. DC Characteristics

($V_{DD} = 2.5\text{ V} \pm 10\%$, or $3.3\text{ V} \pm 10\%$, $T_A = -40\text{ to }85\text{ °C}$)

Parameter	Symbol	Test Condition	Min	Typ	Max	Unit
Core Supply Current	I_{DD}	Enabled 3 outputs	—	22	35	mA
		Enabled 8 outputs	—	27	45	mA
		Power Down (PDN = V_{DD})	—	—	20	µA
Output Buffer Supply Current (Per Output)*	I_{DDOx}	$C_L = 5\text{ pF}$	—	2.2	5	mA
Input Current	I_{CLKIN}	CLKIN, SDA, SCL $V_{in} < 3.6\text{ V}$	—	—	10	µA
	I_{VC}	VC	—	—	30	µA
Output Impedance	Z_O	8 mA output drive current. See "6. Design Considerations" on page 21.	—	85	—	Ω

***Note:** Output clocks less than or equal to 100 MHz.

Table 3. AC Characteristics $(V_{DD} = 2.5\text{ V} \pm 10\%$, or $3.3\text{ V} \pm 10\%$, $T_A = -40$ to $85\text{ }^\circ\text{C}$)

Parameter	Symbol	Test Condition	Min	Typ	Max	Unit
Power-up Time	T_{RDY}	From $V_{DD} = V_{DDmin}$ to valid output clock, $C_L = 5\text{ pF}$, $f_{CLKn} > 1\text{ MHz}$	—	1	10	ms
Output Enable Time	T_{OE}	From OEB pulled low to valid clock output, $C_L = 5\text{ pF}$, $f_{CLKn} > 1\text{ MHz}$	—	—	10	μs
Output Phase Offset	P_{STEP}		—	333	—	ps/step
Spread Spectrum Frequency Deviation	SS_{DEV}	Down spread	-0.1	—	-2.5	%
		Center spread	± 0.1	—	± 1.5	%
Spread Spectrum Modulation Rate	SS_{MOD}		30	31.5	33	kHz
VCXO Specifications (Si5351B only)						
VCXO Control Voltage Range	V_C		0	$V_{DD}/2$	V_{DD}	V
VCXO Gain (configurable)	K_V	$V_C = 10\text{--}90\%$ of V_{DD} , $V_{DD} = 3.3\text{ V}$	18	—	150	ppm/V
VCXO Control Voltage Linearity	K_{VL}	$V_C = 10\text{--}90\%$ of V_{DD}	-5	—	+5	%
VCXO Pull Range (configurable)	PR	$V_{DD} = 3.3\text{ V}^*$	± 30	0	± 240	ppm
VCXO Modulation Bandwidth			—	10	—	kHz
*Note: Contact Silicon Labs for 2.5 V VCXO operation.						

Table 4. Input Clock Characteristics $(V_{DD} = 2.5\text{ V} \pm 10\%$, or $3.3\text{ V} \pm 10\%$, $T_A = -40$ to $85\text{ }^\circ\text{C}$)

Parameter	Symbol	Test Condition	Min	Typ	Max	Units
CLKIN Input Low Voltage	V_{IL}		-0.1	—	$0.3 \times V_{DD}$	V
CLKIN Input High Voltage	V_{IH}		$0.7 \times V_{DD}$	—	3.60	V
CLKIN Frequency Range	f_{CLKIN}		10	—	100	MHz

Si5351A/B/C

Table 5. Output Clock Characteristics

($V_{DD} = 2.5\text{ V} \pm 10\%$, or $3.3\text{ V} \pm 10\%$, $T_A = -40$ to $85\text{ }^\circ\text{C}$)

Parameter	Symbol	Test Condition	Min	Typ	Max	Units
Frequency Range	F_{CLK}		0.008	—	160	MHz
Load Capacitance	C_L		—	5	15	pF
Duty Cycle	DC	Measured at $V_{DD}/2$, $f_{CLK} = 50\text{ MHz}$	45	50	55	%
Rise/Fall Time	t_r	20%–80%, $C_L = 5\text{ pF}$, Drive Strength = 8 mA	0.5	1	1.5	ns
	t_f		0.5	1	1.5	ns
Output High Voltage	V_{OH}	$C_L = 5\text{ pF}$	$V_{DD} - 0.6$	—	—	V
Output Low Voltage	V_{OL}		—	—	0.6	V
Period Jitter	J_{PER}	Measured over 10k cycles	—	35	100	ps pk-pk
Period Jitter VCXO	J_{PER_VCXO}		—	60	110	ps pk-pk
Cycle-to-Cycle Jitter	J_{CC}	Measured over 10k cycles	—	30	90	ps pk
Cycle-to-Cycle Jitter VCXO	J_{CC_VCXO}		—	50	95	ps pk
RMS Phase Jitter	J_{RMS}	12 kHz–20 MHz	—	3.5	11	ps rms
RMS Phase Jitter VCXO	J_{RMS_VCXO}		—	8.5	18.5	ps rms

Table 6. Crystal Requirements^{1,2}

Parameter	Symbol	Min	Typ	Max	Unit
Crystal Frequency	f_{XTAL}	25	—	27	MHz
Load Capacitance	C_L	6	—	12	pF
Equivalent Series Resistance	r_{ESR}	—	—	150	Ω
Crystal Max Drive Level	d_L	—	—	100	μW

Notes:

1. Crystals which require load capacitances of 6, 8, or 10 pF should use the device's internal load capacitance for optimum performance. See register 183 bits 7:6. A crystal with a 12 pF load capacitance requirement should use a combination of the internal 10 pF load capacitors in addition to external 2 pF load capacitors.
2. Refer to "AN551: Crystal Selection Guide" for more details.

Table 7. I²C Specifications (SCL,SDA)¹

Parameter	Symbol	Test Condition	Standard Mode 100 kbps		Fast Mode 400 kbps		Unit
			Min	Max	Min	Max	
LOW Level Input Voltage	V _{ILI2C}		-0.5	0.3 × V _{DDI2C}	-0.5	0.3 × V _{DDI2C} ²	V
HIGH Level Input Voltage	V _{IHI2C}		0.7 × V _{DDI2C}	3.63	0.7 × V _{DDI2C} ²	3.63	V
Hysteresis of Schmitt Trigger Inputs	V _{HYS}		—	—	0.1	—	V
LOW Level Output Voltage (open drain or open collector) at 3 mA Sink Current	V _{OLI2C} ²	V _{DDI2C} ² = 2.5/3.3 V	0	0.4	0	0.4	V
		V _{DDI2C} ² = 1.8 V	—	—	0	0.2 × V _{DDI2C}	V
Input Current	I _{I12C}		-10	10	-10	10	μA
Capacitance for Each I/O Pin	C _{I12C}	V _{IN} = -0.1 to V _{DDI2C}	—	4	—	4	pF
I ² C Bus Timeout	T _{TO}	Timeout Enabled	25	35	25	35	ms

Notes:

1. Refer to NXP's UM10204 I²C-bus specification and user manual, revision 03, for further details, go to: www.nxp.com/acrobat_download/usermanuals/UM10204_3.pdf.
2. Only I²C pullup voltages (V_{DDI2C}) of 2.25 to 3.63 V are supported.

Table 8. Thermal Characteristics

Parameter	Symbol	Test Condition	Package	Value	Unit
Thermal Resistance Junction to Ambient	θ _{JA}	Still Air	10-MSOP	131	°C/W
			24-QSOP	80	°C/W
			20-QFN	51	°C/W
Thermal Resistance Junction to Case	θ _{JC}	Still Air	10-MSOP	43	°C/W
			24-QSOP	31	°C/W
			20-QFN	16	°C/W

Si5351A/B/C

Table 9. Absolute Maximum Ratings¹

Parameter	Symbol	Test Condition	Value	Unit
DC Supply Voltage	V_{DD_max}		-0.5 to 3.8	V
Input Voltage	V_{IN_CLKIN}	CLKIN, SCL, SDA	-0.5 to 3.8	V
	V_{IN_VC}	VC	-0.5 to (VDD+0.3)	V
	$V_{IN_XA/B}$	Pins XA, XB	-0.5 to 1.3 V	V
Junction Temperature	T_J		-55 to 150	°C
Soldering Temperature (Pb-free profile) ²	T_{PEAK}		260	°C
Soldering Temperature Time at TPEAK (Pb-free profile) ²	T_P		20–40	Sec

Notes:

1. Permanent device damage may occur if the absolute maximum ratings are exceeded. Functional operation should be restricted to the conditions as specified in the operational sections of this data sheet. Exposure to absolute maximum rating conditions for extended periods may affect device reliability.
2. The device is compliant with JEDEC J-STD-020.

2. Detailed Block Diagrams

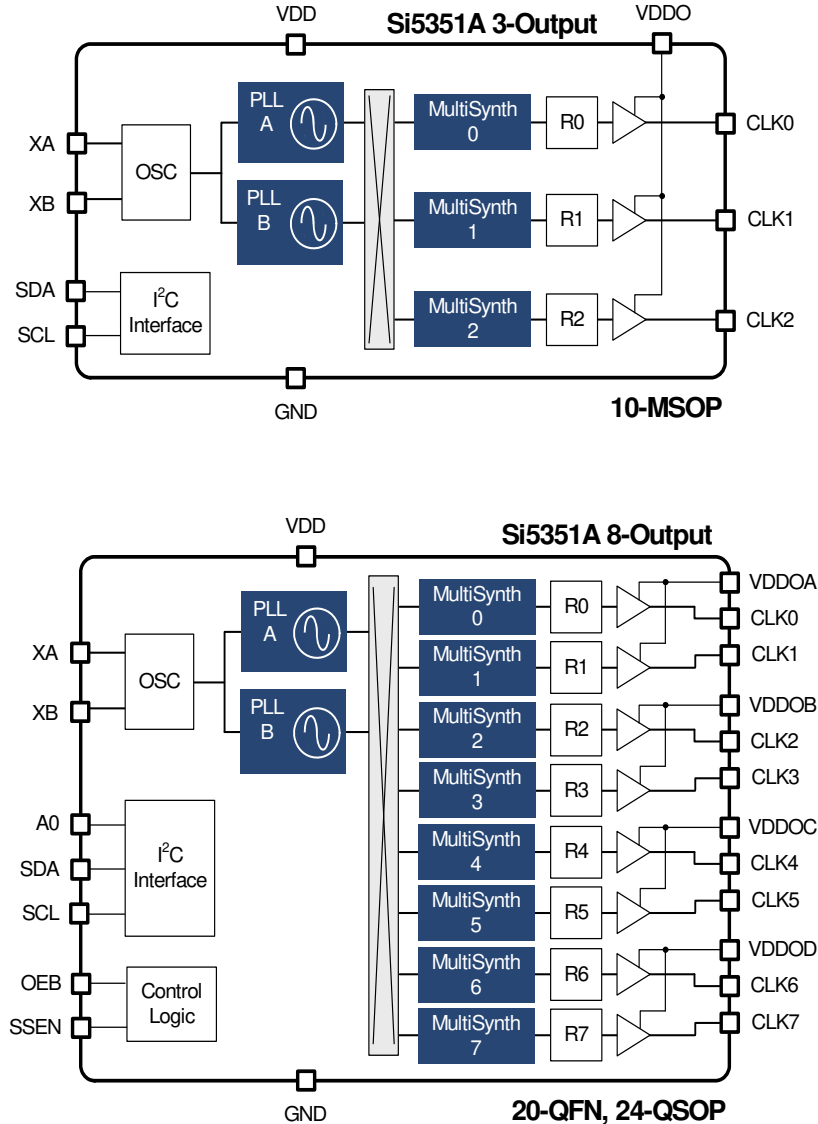

Figure 1. Block Diagrams of 3-Output and 8-Output Si5351A Devices

Si5351A/B/C

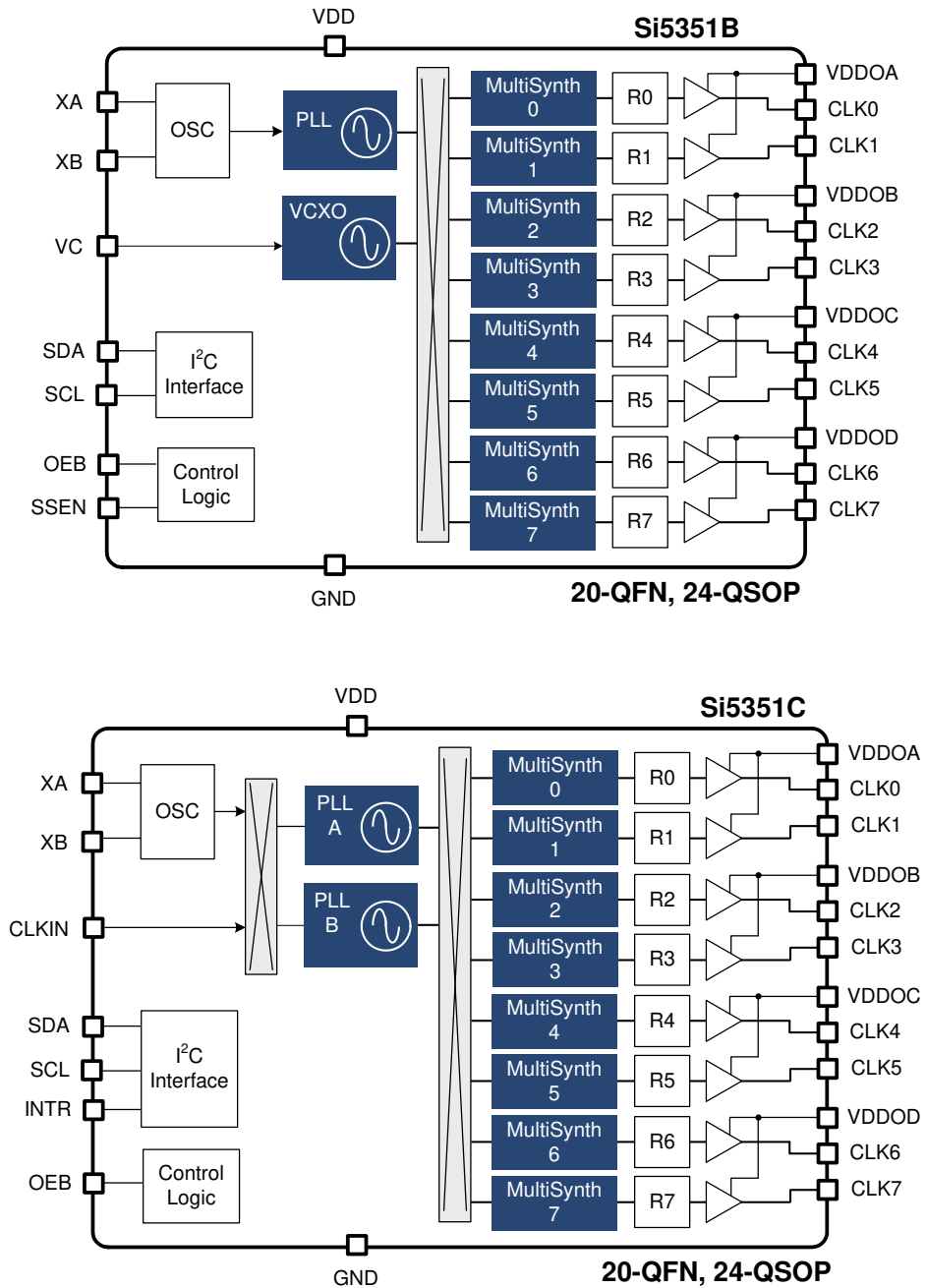

Figure 2. Block Diagrams of Si5351B and Si5351C 8-Output Devices

3. Functional Description

The Si5351 is a versatile I²C programmable clock generator that is ideally suited for replacing crystals, crystal oscillators, VCXOs, PLLs, and buffers. A block diagram showing the general architecture of the Si5351 is shown in Figure 3. The device consists of an input stage, two synthesis stages, and an output stage.

The input stage accepts an external crystal (XTAL), a clock input (CLKIN), or a control voltage input (VC) depending on the version of the device (A/B/C). The first stage of synthesis multiplies the input frequencies to an high-frequency intermediate clock, while the second stage of synthesis uses high resolution MultiSynth fractional dividers to generate the desired output frequencies. Additional integer division is provided at the output stage for generating output frequencies as low as 8 kHz. Crosspoint switches at each of the synthesis stages allows total flexibility in routing any of the inputs to any of the outputs.

Because of this high resolution and flexible synthesis architecture, the Si5351 is capable of generating synchronous or free-running non-integer related clock frequencies at each of its outputs, enabling one device to synthesize clocks for multiple clock domains in a design.

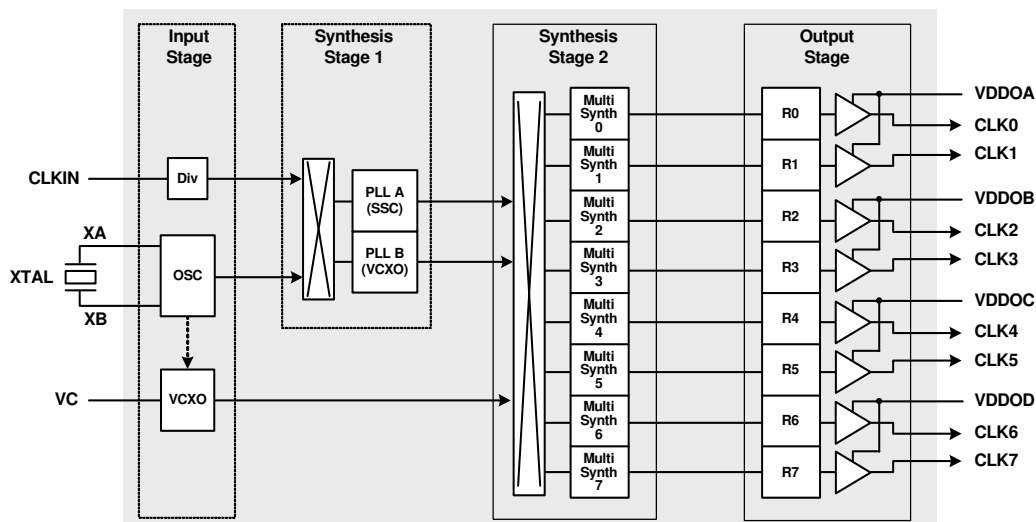

Figure 3. Si5351 Block Diagram

3.1. Input Stage

3.1.1. Crystal Inputs (XA, XB)

The Si5351 uses a fixed-frequency standard AT-cut crystal as a reference to the internal oscillator. The output of the oscillator can be used to provide a free-running reference to one or both of the PLLs for generating asynchronous clocks. The output frequency of the oscillator will operate at the crystal frequency, either 25 MHz or 27 MHz. The crystal is also used as a reference to the VCXO to help maintain its frequency accuracy.

Internal load capacitors (C_L) are provided to eliminate the need for external components when connecting a crystal to the Si5351. Options for internal load capacitors are 6, 8, or 10 pF. Crystals with alternate load capacitance requirements are supported using additional external load capacitors as shown in Figure 4. Refer to application note AN551 for crystal recommendations.

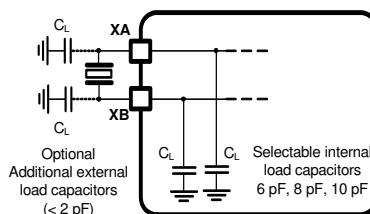

Figure 4. External XTAL with Optional Load Capacitors

Si5351A/B/C

3.1.2. External Clock Input (CLKIN)

The external clock input is used as a clock reference for the PLLs when generating synchronous clock outputs. CLKIN can accept any frequency from 10 to 100 MHz. A divider at the input stage limits the PLL input frequency to 30 MHz.

3.1.3. Voltage Control Input (VC)

The VCXO architecture of the Si5350B eliminates the need for an external pullable crystal. Only a standard, low-cost, fixed-frequency (25 or 27 MHz) AT-cut crystal is required.

The tuning range of the VCXO is configurable allowing for a wide variety of applications. Key advantages of the VCXO design in the Si5351 include high linearity, a wide operating range (linear from 10 to 90% of VDD), and reliable startup and operation. Refer to Table 3 on page 5 for VCXO specification details.

A unique feature of the Si5351B is its ability to generate multiple output frequencies controlled by the same control voltage applied to the VC pin. This replaces multiple PLLs or VCXOs that would normally be locked to the same reference. An example is illustrated in Figure 9 on page 15.

3.2. Synthesis Stages

The Si5351 uses two stages of synthesis to generate its final output clocks. The first stage uses PLLs to multiply the lower frequency input references to a high-frequency intermediate clock. The second stage uses high-resolution MultiSynth fractional dividers to generate frequencies in the range of 1 MHz to 100 MHz. It is also possible to generate two unique frequencies up to 160 MHz on two or more of the outputs.

A crosspoint switch at the input of the first stage allows each of the PLLs to lock to the CLKIN or the XTAL input. This allows each of the PLLs to lock to a different source for generating independent free-running and synchronous clocks. Alternatively, both PLLs could lock to the same source. The crosspoint switch at the input of the second stage allows any of the MultiSynth dividers to connect to PLLA or PLLB. This flexible synthesis architecture allows any of the outputs to generate synchronous or non-synchronous clocks, with spread spectrum or without spread spectrum, and with the flexibility of generating non-integer related clock frequencies at each output.

Since the VCXO already generates a high-frequency intermediate clock, it is fed directly into the second stage of synthesis. The MultiSynth high-resolution dividers synthesize the VCXO center frequency to any frequency in the range of ~391 kHz to 160 MHz. The center frequency is then controlled (or pulled) by the VC input. An interesting feature of the Si5351 is that the VCXO output can be routed to more than one MultiSynth divider. This creates a VCXO with multiple output frequencies controlled from one VC input as shown in Figure 5.

Frequencies down to 8 kHz can be generated by applying the R divider at the output of the Multisynth (see Figure 5 below).

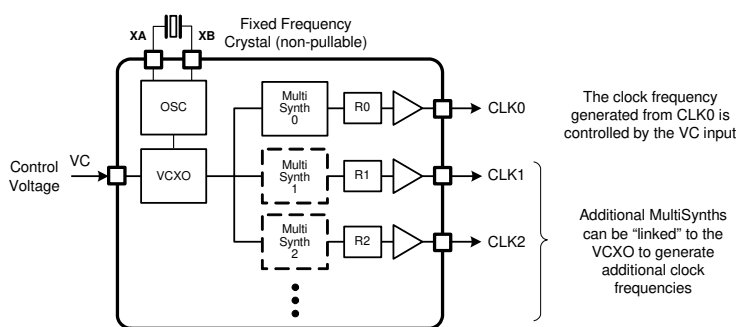

Figure 5. Using the Si5351 as a Multi-Output VCXO

3.3. Output Stage

An additional level of division (R) is available at the output stage for generating clocks as low as 8 kHz. All output drivers generate CMOS level outputs with separate output voltage supply pins (VDDOx) allowing a different voltage signal level (1.8, 2.5, or 3.3 V) at each of the four 2-output banks.

3.4. Spread Spectrum

Spread spectrum can be enabled on any of the clock outputs that use PLLA as its reference. Spread spectrum is useful for reducing electromagnetic interference (EMI). Enabling spread spectrum on an output clock modulates its frequency, which effectively reduces the overall amplitude of its radiated energy. See “AN554: Si5350/51 PCB Layout Guide” for details. Note that spread spectrum is not available on clocks synchronized to PLLB or to the VCXO.

The Si5351 supports several levels of spread spectrum allowing the designer to choose an ideal compromise between system performance and EMI compliance.

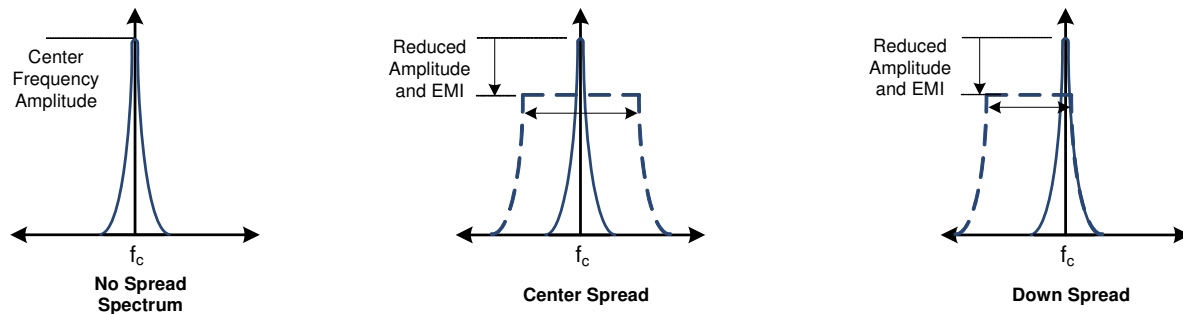

Figure 6. Available Spread Spectrum Profiles

3.5. Control Pins (OEB, SSEN)

The Si5351 offers control pins for enabling/disabling clock outputs and spread spectrum.

3.5.1. Output Enable (OEB)

The output enable pin allows enabling or disabling outputs clocks. Output clocks are enabled when the OEB pin is held low, and disabled when pulled high. When disabled, the output state is configurable as disabled high, disabled low, or disabled in high-impedance.

The output enable control circuitry ensures glitchless operation by starting the output clock cycle on the first leading edge after OEB is pulled low. When OEB is pulled high, the clock is allowed to complete its full clock cycle before going into a disabled state.

3.5.2. Spread Spectrum Enable (SSEN)—Si5351A and Si5351B only

This control pin allows disabling the spread spectrum feature for all outputs that were configured with spread spectrum enabled. Hold SSEN low to disable spread spectrum. The SSEN pin provides a convenient method of evaluating the effect of using spread spectrum clocks during EMI compliance testing.

4. I²C Interface

Many of the functions and features of the Si5351 are controlled by reading and writing to the RAM space using the I²C interface. The following is a list of the common features that are controllable through the I²C interface. A summary of register functions is shown in Section 7.

- Read Status Indicators
 - Loss of signal (LOS) for the CLKIN input
 - Loss of lock (LOL) for PLLA and PLLB
- Configuration of multiplication and divider values for the PLLs, MultiSynth dividers
- Configuration of the Spread Spectrum profile (down or center spread, modulation percentage)
- Control of the cross point switch selection for each of the PLLs and MultiSynth dividers
- Set output clock options
 - Enable/disable for each clock output
 - Invert/non-invert for each clock output
 - Output divider values (2^n , $n=1..7$)
 - Output state when disabled (stop hi, stop low, Hi-Z)
 - Output phase offset

The I²C interface operates in slave mode with 7-bit addressing and can operate in Standard-Mode (100 kbps) or Fast-Mode (400 kbps) and supports burst data transfer with auto address increments.

The I²C bus consists of a bidirectional serial data line (SDA) and a serial clock input (SCL) as shown in Figure 7. Both the SDA and SCL pins must be connected to the VDD supply via an external pull-up as recommended by the I²C specification.

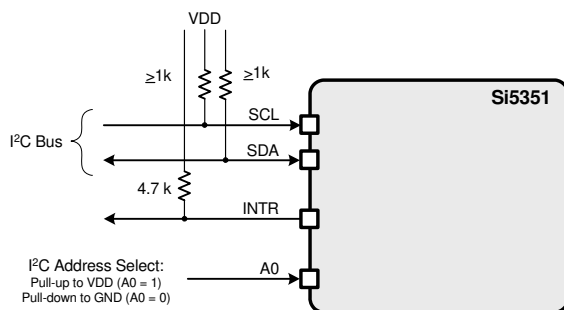

Figure 7. I²C and Control Signals

The 7-bit device (slave) address of the Si5351 consist of a 6-bit fixed address plus a user selectable LSB bit as shown in Figure 8. The LSB bit is selectable as 0 or 1 using the optional A0 pin which is useful for applications that require more than one Si5351 on a single I²C bus.

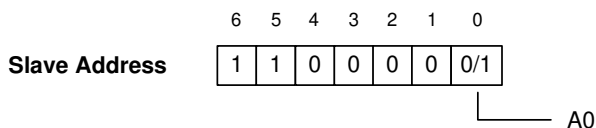
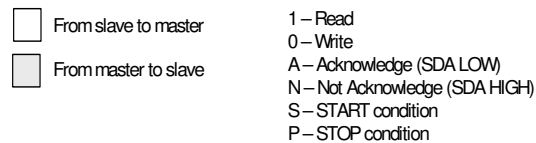
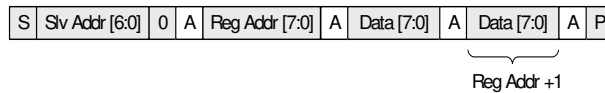
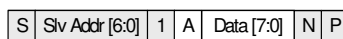
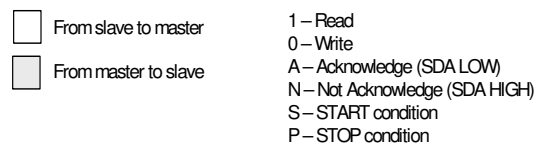

Figure 8. Si5351 I²C Slave Address

Data is transferred MSB first in 8-bit words as specified by the I²C specification. A write command consists of a 7-bit device (slave) address + a write bit, an 8-bit register address, and 8 bits of data as shown in Figure 9. A write burst operation is also shown where every additional data word is written using to an auto-incremented address.

Write Operation – Single Byte**Write Operation - Burst (Auto Address Increment)****Figure 9. I²C Write Operation**

A read operation is performed in two stages. A data write is used to set the register address, then a data read is performed to retrieve the data from the set address. A read burst operation is also supported. This is shown in Figure 10.

Read Operation – Single Byte**Read Operation - Burst (Auto Address Increment)****Figure 10. I²C Read Operation**

AC and DC electrical specifications for the SCL and SDA pins are shown in Table 7. The timing specifications and timing diagram for the I²C bus is compatible with the I²C-Bus Standard. SDA timeout is supported for compatibility with SMBus interfaces.

5. Configuring the Si5351

The Si5351 is a highly flexible clock generator which is entirely configurable through its I²C interface. The device's default configuration is stored in non-volatile memory (NVM) as shown in Figure 11. The NVM is a one time programmable memory (OTP) which can store a custom user configuration at power-up. This is a useful feature for applications that need a clock present at power-up (e.g., for providing a clock to a processor).

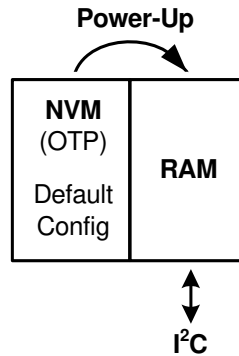

Figure 11. Si5351 Memory Configuration

During a power cycle the contents of the NVM are copied into random access memory (RAM), which sets the device configuration that will be used during normal operation. Any changes to the device configuration after power-up are made by reading and writing to registers in the RAM space through the I²C interface. A detailed register map is shown in Section "8. Register Descriptions" on page 25.

5.1. Writing a Custom Configuration to RAM

To simplify device configuration, Silicon Labs has released the ClockBuilder Desktop. The software serves two purposes: to configure the Si5351 with optimal configuration based on the desired frequencies and to control the EVB when connected to a host PC.

The optimal configuration can be saved from the software in text files that can be used in any system, which configures the device over I²C. ClockBuilder Desktop can be downloaded from www.silabs.com/ClockBuilder and runs on Windows XP, Windows Vista, and Windows 7.

Once the configuration file has been saved, the device can be programmed via I²C by following the steps shown in Figure 12.

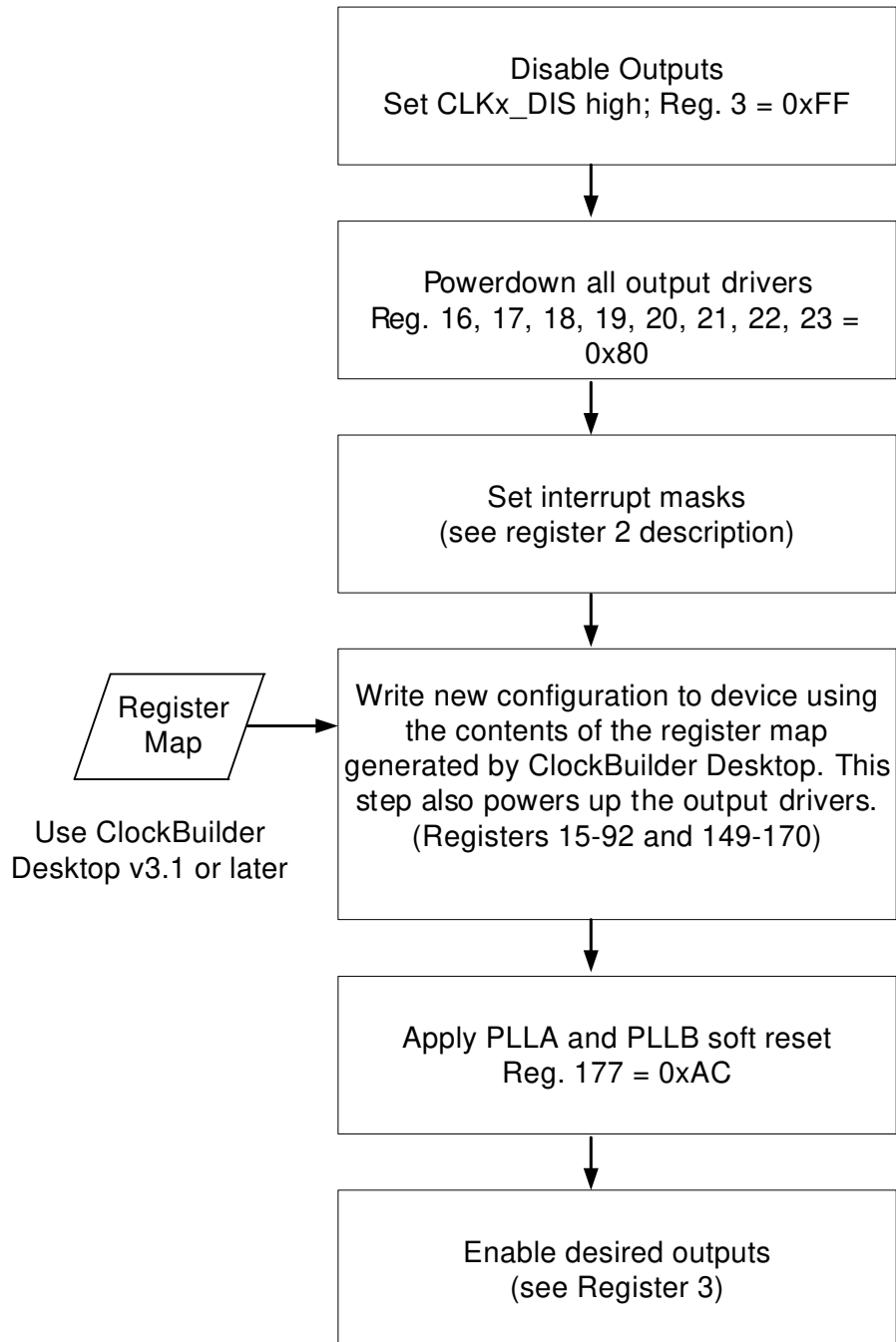
**Figure 12. I²C Programming Procedure**

Si5351A/B/C

5.2. Si5351 Application Examples

The Si5351 is a versatile clock generator which serves a wide variety of applications. The following examples show how it can be used to replace crystals, crystal oscillators, VCXOs, and PLLs.

5.3. Replacing Crystals and Crystal Oscillators

Using an inexpensive external crystal, the Si5351A can generate up to 8 different free-running clock frequencies for replacing crystals and crystal oscillators. A 3-output version packaged in a small 10-MSOP is also available for applications that require fewer clocks. An example is shown in Figure 13.

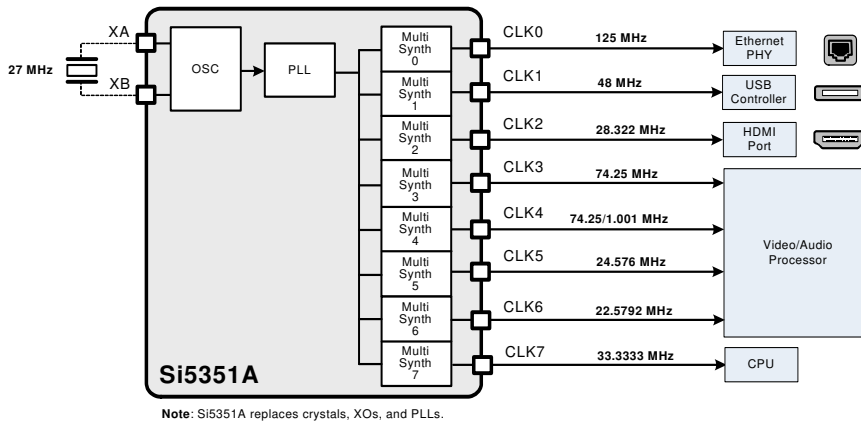

Figure 13. Using the Si5351A to Replace Multiple Crystals, Crystal Oscillators, and PLLs

5.4. Replacing Crystals, Crystal Oscillators, and VCXOs

The Si5351B combines free-running clock generation and a VCXO in a single package for cost sensitive video applications. An example is shown in Figure 14.

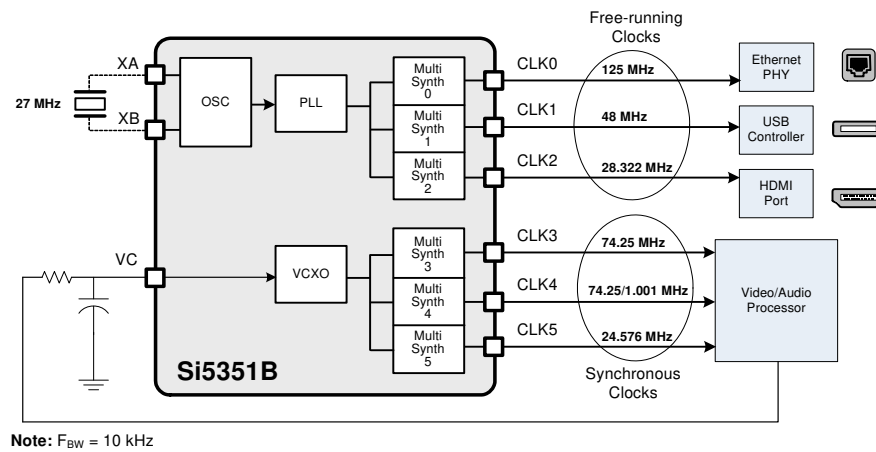

Figure 14. Using the Si5351B to Replace Crystals, Crystal Oscillators, VCXOs, and PLLs

5.5. Replacing Crystals, Crystal Oscillators, and PLLs

The Si5351C generates synchronous clocks for applications that require a fully integrated PLL instead of a VCXO. Because of its dual PLL architecture, the Si5351C is capable of generating both synchronous and free-running clocks. An example is shown in Figure 15.

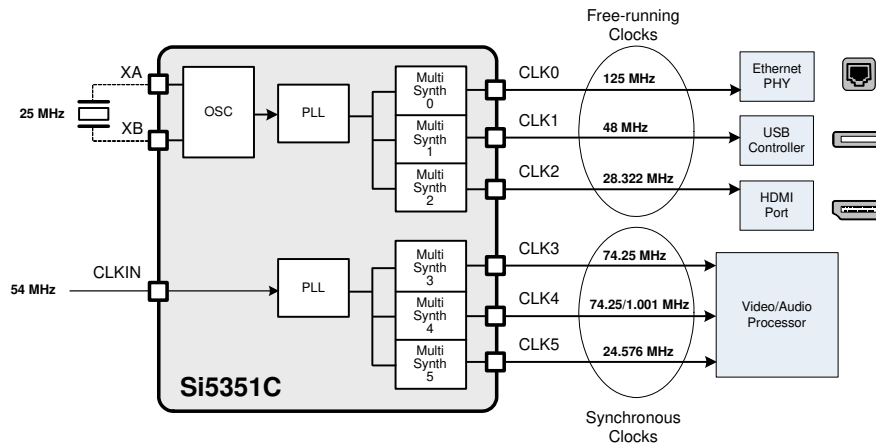

Figure 15. Using the Si5351C to Replace Crystals, Crystal Oscillators, and PLLs

Si5351A/B/C

5.6. Replacing a Crystal with a Clock

The Si5351 can be driven with a clock signal through the XA input pin.

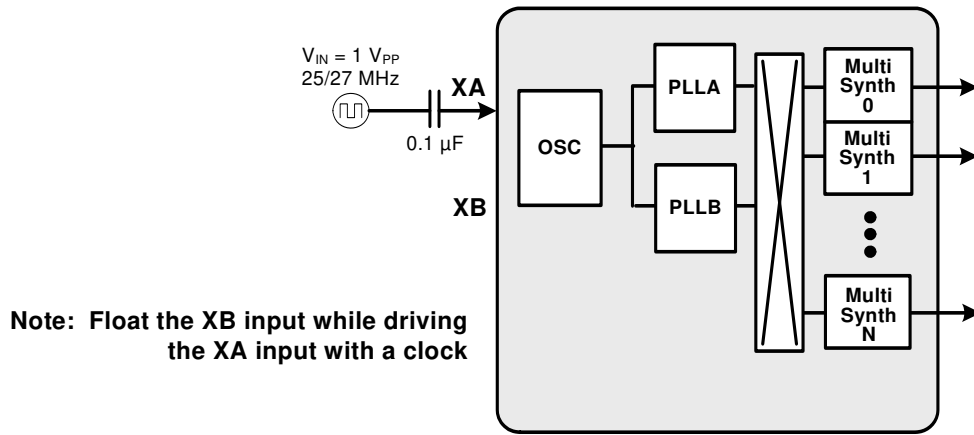

Figure 16. Si5351 Driven by a Clock Signal

5.7. HCSL Compatible Outputs

The Si5351 can be configured to support HCSL compatible swing when the VDDO of the output pair of interest is set to 2.5 V (i.e., VDDOA must be 2.5 V when using CLK0/1; VDDOB must be 2.5 V for CLK2/3 and so on).

The circuit in the figure below must be applied to each of the two clocks used, and one of the clocks in the pair must also be inverted to generate a differential pair. See register setting CLKx_INV.

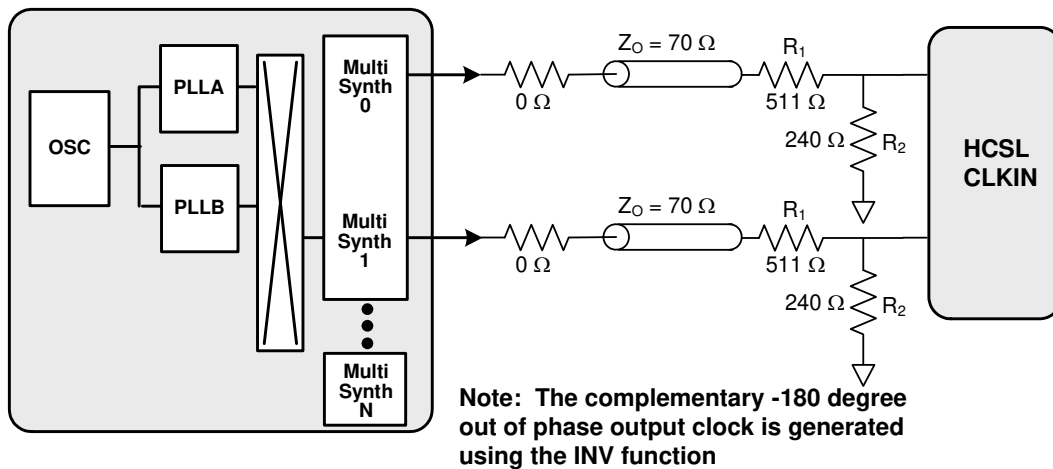

Figure 17. Si5350C Output is HCSL Compatible

6. Design Considerations

The Si5351 is a self-contained clock generator that requires very few external components. The following general guidelines are recommended to ensure optimum performance. Refer to “AN554: Si5350/51 PCB Layout Guide” for additional layout recommendations.

6.1. Power Supply Decoupling/Filtering

The Si5351 has built-in power supply filtering circuitry and extensive internal Low Drop Out (LDO) voltage regulators to help minimize the number of external bypass components. All that is recommended is one 0.1 μ F decoupling capacitor per power supply pin. This capacitor should be mounted as close to the VDD and VDDOx pins as possible without using vias.

6.2. Power Supply Sequencing

The VDD and VDDOx (i.e., VDDO0, VDDO1, VDDO2, VDDO3) power supply pins have been separated to allow flexibility in output signal levels. If a minimum output-to-output skew is important, then all VDDOx must be applied before VDD. Unused VDDOx pins should be tied to VDD.

6.3. External Crystal

The external crystal should be mounted as close to the pins as possible using short PCB traces. The XA and XB traces should be kept away from other high-speed signal traces. See “AN551: Crystal Selection Guide” for more details.

6.4. External Crystal Load Capacitors

The Si5351 provides the option of using internal and external crystal load capacitors. If internal load capacitance is insufficient, capacitors of value ≤ 2 pF may be used to increased equivalent load capacitance. If external load capacitors are used, they should be placed as close to the XA/XB pads as possible. See AN554 for more details.

6.5. Unused Pins

Unused voltage control pin should be tied to GND.

Unused CLKIN pin should be tied to GND.

Unused XA/XB pins should be left floating. Refer to "5.6. Replacing a Crystal with a Clock" on page 20 when using XA as a clock input pin.

Unused output pins (CLK0–CLK7) should be left floating.

Unused VDDOx pins should be tied to VDD.

6.6. Trace Characteristics

The Si5351A/B/C features various output current drives ranging from 2 to 8 mA (default). It is recommended to configure the trace characteristics as shown in Figure 18 when an output drive setting of 8 mA is used.

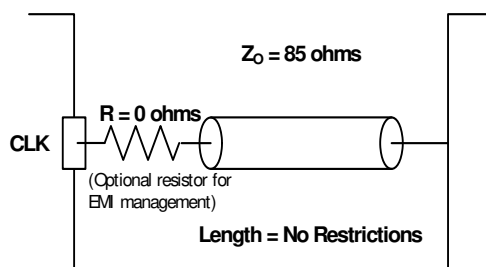

Figure 18. Recommended Trace Characteristics with 8 mA Drive Strength Setting

Note: Jitter is only specified at 6 and 8 mA drive strength.

7. Register Map Summary

The following is a summary of the register map used to read status, control, and configure the Si5351.

Register	7	6	5	4	3	2	1	0
0	SYS_INIT	LOL_B	LOL_A	LOS			REVID[1:0]	
1	SYSCAL_STKY	LOS_B_STKY	LOL_A_STKY	LOS_STKY				
2	SYSCAL_MASK	LOS_B_MASK	LOL_A_MASK	LOS_MASK				
3	CLK7_EN	CLK6_EN	CLK5_EN	CLK4_EN	CLK3_EN	CLK2_EN	CLK1_EN	CLK0_EN
4–8	Reserved							
9	OEB_CLK7	OEB_CLK6	OEB_CLK5	OEB_CLK4	OEB_CLK3	OEB_CLK2	OEB_CLK1	OEB_CLK0
10–14	Reserved							
15	0	0	0	0	PLLB_SRC	PLLA_SRC	0	0
16	CLK0_PDN	MS0_INT	MS0_SRC	CLK0_INV	CLK0_SRC[1:0]		CLK0_IDRV[1:0]	
17	CLK1_PDN	MS1_INT	MS1_SRC	CLK1_INV	CLK1_SRC[1:0]		CLK1_IDRV[1:0]	
18	CLK2_PDN	MS2_INT	MS2_SRC	CLK2_INV	CLK2_SRC[1:0]		CLK2_IDRV[1:0]	
19	CLK3_PDN	MS3_INT	MS3_SRC	CLK3_INV	CLK3_SRC[1:0]		CLK3_IDRV[1:0]	
20	CLK4_PDN	MS4_INT	MS4_SRC	CLK4_INV	CLK4_SRC[1:0]		CLK4_IDRV[1:0]	
21	CLK5_PDN	MS5_INT	MS5_SRC	CLK5_INV	CLK5_SRC[1:0]		CLK5_IDRV[1:0]	
22	CLK6_PDN	FBA_INT	MS6_SRC	CLK6_INV	CLK6_SRC[1:0]		CLK6_IDRV[1:0]	
23	CLK7_PDN	FBB_INT	MS6_SRC	CLK7_INV	CLK7_SRC[1:0]		CLK7_IDRV[1:0]	
24	CLK3_DIS_STATE		CLK2_DIS_STATE		CLK1_DIS_STATE		CLK0_DIS_STATE	
25	CLK7_DIS_STATE		CLK6_DIS_STATE		CLK5_DIS_STATE		CLK4_DIS_STATE	
26–41	PLL, MultiSynth, and output clock delay offset Configuration Registers. Use ClockBuilder Desktop Software to Determine These Register Values.							
42	MS0_P3[15:8]							
43	MS0_P3[7:0]							
44	R0_DIV[2:0]				MS0_P1[17:16]			
45	MS0_P1[15:8]							
46	MS0_P1[7:0]							
47	MS0_P3[19:16]				MS0_P2[19:16]			
48	MS0_P2[15:8]							
49	MS0_P2[7:0]							
50	MS1_P3[15:8]							
51	MS1_P3[7:0]							
52	R1_DIV[2:0]				MS1_P1[17:16]			
53	MS1_P1[15:8]							
54	MS1_P1[7:0]							
55	MS1_P3[19:16]				MS1_P2[19:16]			
56	MS1_P2[15:8]							
57	MS1_P2[7:0]							
58	MS2_P3[15:8]							
59	MS2_P3[7:0]							
60	R2_DIV[2:0]				MS2_P1[17:16]			
61	MS2_P1[15:8]							
62	MS2_P1[7:0]							
63	MS2_P3[19:16]				MS2_P2[19:16]			
64	MS2_P2[15:8]							
65	MS2_P2[7:0]							

Si5351A/B/C

Register	7	6	5	4	3	2	1	0
66	MS3_P3[15:8]							
67	MS3_P3[7:0]							
68	R3_DIV[2:0]				MS3_P1[17:16]			
69	MS3_P1[15:8]							
70	MS3_P1[7:0]							
71	MS3_P3[19:16]				MS3_P2[19:16]			
72	MS3_P2[15:8]							
73	MS3_P2[7:0]							
74	MS4_P3[15:8]							
75	MS4_P3[7:0]							
76	R4_DIV[2:0]				MS4_P1[17:16]			
77	MS4_P1[15:8]							
78	MS4_P1[7:0]							
79	MS4_P3[19:16]				MS4_P2[19:16]			
80	MS4_P2[15:8]							
81	MS4_P2[7:0]							
82	MS5_P3[15:8]							
83	MS5_P3[7:0]							
84	R5_DIV[2:0]				MS5_P1[17:16]			
85	MS5_P1[15:8]							
86	MS5_P1[7:0]							
87	MS5_P3[19:16]				MS5_P2[19:16]			
88	MS5_P2[15:8]							
89	MS5_P2[7:0]							
90	MS6_P1[7:0]							
91	MS7_P1[7:0]							
92	R7_DIV[2:0]				R6_DIV[2:0]			
93–164	PLL, MultiSynth, and output clock delay offset Configuration Registers. Use ClockBuilder Desktop Software to Determine These Register Values.							
165	CLK0_PHOFF[7:0]							
166	CLK1_PHOFF[7:0]							
167	CLK2_PHOFF[7:0]							
168	CLK3_PHOFF[7:0]							
189	CLK4_PHOFF[7:0]							
170	CLK5_PHOFF[7:0]							
173–176	Reserved							
177	PLL_B_RST		PLL_A_RST					
178–182	Reserved							
183	XTAL_CL							
184–255	Reserved							

8. Register Descriptions

Register 0. Device Status

Bit	D7	D6	D5	D4	D3	D2	D1	D0
Name	SYS_INIT	LOL_B	LOL_A	LOS			REVID[1:0]	
Type	R	R	R	R	R	R	R	

Reset value = 0000 0000

Bit	Name	Function
7	SYS_INIT	<p>System Initialization Status.</p> <p>During power up the device copies the content of the NVM into RAM and performs a system initialization. The device is not operational until initialization is complete. It is not recommended to read or write registers in RAM through the I²C interface until initialization is complete. An interrupt will be triggered (INTR pin = 0, Si5351C only) during the system initialization period.</p> <p>0: System initialization is complete. Device is ready. 1: Device is in system initialization mode.</p>
6	LOL_B	<p>PLL B Loss Of Lock Status.</p> <p>Si5351A/C only. PLL B will operate in a locked state when it has a valid reference from CLKIN or XTAL. A loss of lock will occur if the frequency of the reference clock forces the PLL to operate outside of its lock range as specified in Table 3, or if the reference clock fails to meet the minimum requirements of a valid input signal as specified in Table 4. An interrupt will be triggered (INTR pin = 0, Si5351C) during a LOL condition.</p> <p>0: PLL B is locked. 1: PLL B is unlocked. When the device is in this state it will trigger an interrupt causing the INTR pin to go low (Si5351C only).</p>
5	LOL_A	<p>PLL A Loss Of Lock Status.</p> <p>PLL A will operate in a locked state when it has a valid reference from CLKIN or XTAL. A loss of lock will occur if the frequency of the reference clock forces the PLL to operate outside of its lock range as specified in Table 3, or if the reference clock fails to meet the minimum requirements of a valid input signal as specified in Table 4. An interrupt will be triggered (INTR pin = 0, Si5351C only) during a LOL condition.</p> <p>0: PLL A is operating normally. 1: PLL A is unlocked. When the device is in this state it will trigger an interrupt causing the INTR pin to go low (Si5351C only).</p>
4	LOS	<p>CLKIN Loss Of Signal (Si5351C Only).</p> <p>A loss of signal status indicates if the reference clock fails to meet the minimum requirements of a valid input signal as specified in Table 4. An interrupt will be triggered (INTR pin = 0, Si5351C only) during a LOS condition.</p> <p>0: Valid clock signal at the CLKIN pin. 1: Loss of signal detected at the CLKIN pin.</p>
3:2	Reserved	Leave as default.
1:0	REVID[1:0]	Revision ID. Device revision number. Set at the factory.

Si5351A/B/C

Register 1. Interrupt Status Sticky

Bit	D7	D6	D5	D4	D3	D2	D1	D0
Name	SYS_INIT_STKY	LOL_B_STKY	LOL_A_STKY	LOS_STKY				
Type	R/W	R/W	R/W	R/W	R/W	R/W	R/W	R/W

Reset value = 0000 0000

Bit	Name	Function
7	SYS_INIT_STKY	<p>System Calibration Status Sticky Bit.</p> <p>The SYS_INIT_STKY bit is triggered when the SYS_INIT bit (register 0, bit 7) is triggered high. It remains high until cleared. Writing a 0 to this register bit will cause it to clear.</p> <p>0: No SYS_INIT interrupt has occurred since it was last cleared. 1: A SYS_INIT interrupt has occurred since it was last cleared.</p>
6	LOL_B_STKY	<p>PLL B Loss Of Lock Status Sticky Bit.</p> <p>The LOL_B_STKY bit is triggered when the LOL_B bit (register 0, bit 6) is triggered high. It remains high until cleared. Writing a 0 to this register bit will cause it to clear.</p> <p>0: No PLL B interrupt has occurred since it was last cleared. 1: A PLL B interrupt has occurred since it was last cleared.</p>
5	LOL_A_STKY	<p>PLLA Loss Of Lock Status Sticky Bit.</p> <p>The LOL_A_STKY bit is triggered when the LOL_A bit (register 0, bit 5) is triggered high. It remains high until cleared. Writing a 0 to this register bit will cause it to clear.</p> <p>0: No PLLA interrupt has occurred since it was last cleared. 1: A PLLA interrupt has occurred since it was last cleared.</p>
4	LOS_STKY	<p>CLKIN Loss Of Signal Sticky Bit (Si5351C Only).</p> <p>The LOS_STKY bit is triggered when the LOS bit (register 0, bit 4) is triggered high. It remains high until cleared. Writing a 0 to this register bit will cause it to clear.</p> <p>0: No LOS interrupt has occurred since it was last cleared. 1: A LOS interrupt has occurred since it was last cleared.</p>
3:0	Reserved	Leave as default.

Register 2. Interrupt Status Mask

Bit	D7	D6	D5	D4	D3	D2	D1	D0
Name	SYS_INIT_MASK	LOL_B_MASK	LOL_A_MASK	LOS_MASK				
Type	R/W	R/W	R/W	R/W	R/W	R/W	R/W	R/W

Reset value = 0000 0000

Bit	Name	Function
7	SYS_INIT_MASK	<p>System Initialization Status Mask.</p> <p>Use this mask bit to prevent the INTR pin (Si5351C only) from going low when SYS_INIT is asserted.</p> <p>0: Do not mask the SYS_INIT interrupt.</p> <p>1: Mask the SYS_INIT interrupt.</p>
6	LOL_B_MASK	<p>PLL B Loss Of Lock Status Mask.</p> <p>Use this mask bit to prevent the INTR pin (Si5351C only) from going low when LOL_B is asserted.</p> <p>0: Do not mask the LOL_B interrupt.</p> <p>1: Mask the LOL_B interrupt.</p>
5	LOL_A_MASK	<p>PLL A Loss Of Lock Status Mask.</p> <p>Use this mask bit to prevent the INTR pin (Si5351C only) from going low when LOL_A is asserted.</p> <p>0: Do not mask the LOL_A interrupt.</p> <p>1: Mask the LOL_A interrupt.</p>
4	LOS_MASK	<p>CLKIN Loss Of Signal Mask (Si5351C Only).</p> <p>Use this mask bit to prevent the INTR pin (Si5351C only) from going low when LOS is asserted.</p> <p>0: Do not mask the LOS interrupt.</p> <p>1: Mask the LOS interrupt.</p>
3:0	Reserved	Leave as default.

Si5351A/B/C

Register 3. Output Enable Control

Bit	D7	D6	D5	D4	D3	D2	D1	D0
Name	CLK7_OEB	CLK6_OEB	CLK5_OEB	CLK4_OEB	CLK3_OEB	CLK2_OEB	CLK1_OEB	CLK0_OEB
Type	R/W	R/W	R/W	R/W	R/W	R/W	R/W	R/W

Reset value = 0000 0000

Bit	Name	Function
7:0	CLKx_OEB	Output Disable for CLKx. Where x = 0, 1, 2, 3, 4, 5, 6, 7 0: Enable CLKx output. 1: Disable CLKx output.

Register 9. OEB Pin Enable Control

Bit	D7	D6	D5	D4	D3	D2	D1	D0
Name	OEB_CLK7	OEB_CLK6	OEB_CLK5	OEB_CLK4	OEB_CLK3	OEB_CLK2	OEB_CLK1	OEB_CLK0
Type	R/W	R/W	R/W	R/W	R/W	R/W	R/W	R/W

Reset value = 0000 0000

Bit	Name	Function
7:0	OEB_CLKx	OEB pin enable control of CLKx. Where x = 0, 1, 2, 3, 4, 5, 6, 7 0: OEB pin controls enable/disable state of CLKx output. 1: OEB pin does not control enable/disable state of CLKx output.

Register 15. PLL Input Source

Bit	D7	D6	D5	D4	D3	D2	D1	D0
Name					PLLB_SRC	PLLA_SRC		
Type	R/W	R/W	R/W	R/W	R/W	R/W	R/W	R/W

Reset value = 0000 0000

Bit	Name	Function
7:4	Reserved	Leave as default.
3	PLLB_SRC	Input Source Select for PLLB. 0: Select the XTAL input as the reference clock for PLLB (Si5351A/C only). 1: Select the CLKIN input as the reference clock for PLLB (Si5351C only).
2	PLLA_SRC	Input Source Select for PLLA. 0: Select the XTAL input as the reference clock for PLLA. 1: Select the CLKIN input as the reference clock for PLLA (Si5351C only).
1:0	Reserved	Leave as default.

Si5351A/B/C

Register 16. CLK0 Control

Bit	D7	D6	D5	D4	D3	D2	D1	D0
Name	CLK0_PDN	MS0_INT	MS0_SRC	CLK0_INV	CLK0_SRC[1:0]		CLK0_IDRV[1:0]	
Type	R/W	R/W	R/W	R/W	R/W		R/W	

Reset value = 0000 0000

Bit	Name	Function
7	CLK0_PDN	<p>Clock 0 Power Down.</p> <p>This bit allows powering down the CLK0 output driver to conserve power when the output is unused.</p> <p>0: CLK0 is powered up.</p> <p>1: CLK0 is powered down.</p>
6	MS0_INT	<p>MultiSynth 0 Integer Mode.</p> <p>This bit can be used to force MS0 into Integer mode to improve jitter performance. Note that the fractional mode is necessary when a delay offset is specified for CLK0.</p> <p>0: MS0 operates in fractional division mode.</p> <p>1: MS0 operates in integer mode.</p>
5	MS0_SRC	<p>MultiSynth Source Select for CLK0.</p> <p>0: Select PLLA as the source for MultiSynth0.</p> <p>1: Select PLLB (Si5351A/C only) or VCXO (Si5351B only) MultiSynth0.</p>
4	CLK0_INV	<p>Output Clock 0 Invert.</p> <p>0: Output Clock 0 is not inverted.</p> <p>1: Output Clock 0 is inverted.</p>
3:2	CLK0_SRC[1:0]	<p>Output Clock 0 Input Source.</p> <p>These bits determine the input source for CLK0.</p> <p>00: Select the XTAL as the clock source for CLK0. This option by-passes both synthesis stages (PLL/VCXO & MultiSynth) and connects CLK0 directly to the oscillator which generates an output frequency determined by the XTAL frequency.</p> <p>01: Select CLKIN as the clock source for CLK0. This by-passes both synthesis stages (PLL/VCXO & MultiSynth) and connects CLK0 directly to the CLKIN input. This essentially creates a buffered output of the CLKIN input.</p> <p>10: Reserved. Do not select this option.</p> <p>11: Select MultiSynth 0 as the source for CLK0. Select this option when using the Si5351 to generate free-running or synchronous clocks.</p>
1:0	CLK0_IDRV[1:0]	<p>CLK0 Output Rise and Fall time / Drive Strength Control.</p> <p>00: 2 mA</p> <p>01: 4 mA</p> <p>10: 6 mA</p> <p>11: 8 mA</p>

Register 17. CLK1 Control

Bit	D7	D6	D5	D4	D3	D2	D1	D0
Name	CLK1_PDN	MS1_INT	MS1_SRC	CLK1_INV	CLK1_SRC[1:0]		CLK1_IDRV[1:0]	
Type	R/W	R/W	R/W	R/W	R/W		R/W	

Reset value = 0000 0000

Bit	Name	Function
7	CLK1_PDN	Clock 1 Power Down. This bit allows powering down the CLK1 output driver to conserve power when the output is unused. 0: CLK1 is powered up. 1: CLK1 is powered down.
6	MS1_INT	MultiSynth 1 Integer Mode. This bit can be used to force MS1 into Integer mode to improve jitter performance. Note that the fractional mode is necessary when a delay offset is specified for CLK1. 0: MS1 operates in fractional division mode. 1: MS1 operates in integer mode.
5	MS1_SRC	MultiSynth Source Select for CLK1. 0: Select PLLA as the source for MultiSynth0. 1: Select PLLB (Si5351A/C only) or VCXO (Si5351B only) MultiSynth0.
4	CLK1_INV	Output Clock 1 Invert. 0: Output Clock 1 is not inverted. 1: Output Clock 1 is inverted.
3:2	CLK1_SRC[1:0]	Output Clock 1 Input Source. These bits determine the input source for CLK1. 00: Select the XTAL as the clock source for CLK1. This option by-passes both synthesis stages (PLL/VCXO & MultiSynth) and connects CLK1 directly to the oscillator which generates an output frequency determined by the XTAL frequency. 01: Select CLKIN as the clock source for CLK1. This by-passes both synthesis stages (PLL/VCXO & MultiSynth) and connects CLK1 directly to the CLKIN input. This essentially creates a buffered output of the CLKIN input. 10: Reserved. Do not select this option. 11: Select MultiSynth 0 as the source for CLK1. Select this option when using the Si5351 to generate free-running or synchronous clocks.
1:0	CLK1_IDRV[1:0]	CLK1 Output Rise and Fall time / Drive Strength Control. 00: 2 mA 01: 4 mA 10: 6 mA 11: 8 mA

Si5351A/B/C

Register 18. CLK2 Control

Bit	D7	D6	D5	D4	D3	D2	D1	D0
Name	CLK2_PDN	MS2_INT	MS2_SRC	CLK2_INV	CLK2_SRC[1:0]		CLK2_IDRV[1:0]	
Type	R/W	R/W	R/W	R/W	R/W		R/W	

Reset value = 0000 0000

Bit	Name	Function
7	CLK2_PDN	<p>Clock 2 Power Down.</p> <p>This bit allows powering down the CLK2 output driver to conserve power when the output is unused.</p> <p>0: CLK2 is powered up.</p> <p>1: CLK2 is powered down.</p>
6	MS2_INT	<p>MultiSynth 2 Integer Mode.</p> <p>This bit can be used to force MS2 into Integer mode to improve jitter performance. Note that the fractional mode is necessary when a delay offset is specified for CLK2.</p> <p>0: MS2 operates in fractional division mode.</p> <p>1: MS2 operates in integer mode.</p>
5	MS2_SRC	<p>MultiSynth Source Select for CLK2.</p> <p>0: Select PLLA as the source for MultiSynth0.</p> <p>1: Select PLLB (Si5351A/C only) or VCXO (Si5351B only) MultiSynth0.</p>
4	CLK2_INV	<p>Output Clock 2 Invert.</p> <p>0: Output Clock 2 is not inverted.</p> <p>1: Output Clock 2 is inverted.</p>
3:2	CLK2_SRC[1:0]	<p>Output Clock 2 Input Source.</p> <p>These bits determine the input source for CLK2.</p> <p>00: Select the XTAL as the clock source for CLK2. This option by-passes both synthesis stages (PLL/VCXO & MultiSynth) and connects CLK2 directly to the oscillator which generates an output frequency determined by the XTAL frequency.</p> <p>01: Select CLKIN as the clock source for CLK2. This by-passes both synthesis stages (PLL/VCXO & MultiSynth) and connects CLK2 directly to the CLKIN input. This essentially creates a buffered output of the CLKIN input.</p> <p>10: Reserved. Do not select this option.</p> <p>11: Select MultiSynth 0 as the source for CLK2. Select this option when using the Si5351 to generate free-running or synchronous clocks.</p>
1:0	CLK2_IDRV[1:0]	<p>CLK2 Output Rise and Fall time / Drive Strength Control.</p> <p>00: 2 mA</p> <p>01: 4 mA</p> <p>10: 6 mA</p> <p>11: 8 mA</p>

Register 19. CLK3 Control

Bit	D7	D6	D5	D4	D3	D2	D1	D0
Name	CLK3_PDN	MS3_INT	MS3_SRC	CLK3_INV	CLK3_SRC[1:0]		CLK3_IDRV[1:0]	
Type	R/W	R/W	R/W	R/W	R/W		R/W	

Reset value = 0000 0000

Bit	Name	Function
7	CLK3_PDN	Clock 3 Power Down. This bit allows powering down the CLK3 output driver to conserve power when the output is unused. 0: CLK3 is powered up. 1: CLK3 is powered down.
6	MS3_INT	MultiSynth 3 Integer Mode. This bit can be used to force MS3 into Integer mode to improve jitter performance. Note that the fractional mode is necessary when a delay offset is specified for CLK3. 0: MS3 operates in fractional division mode. 1: MS3 operates in integer mode.
5	MS3_SRC	MultiSynth Source Select for CLK3. 0: Select PLLA as the source for MultiSynth0. 1: Select PLLB (Si5351A/C only) or VCXO (Si5351B only) MultiSynth0.
4	CLK3_INV	Output Clock 3 Invert. 0: Output Clock 3 is not inverted. 1: Output Clock 3 is inverted.
3:2	CLK3_SRC[1:0]	Output Clock 3 Input Source. These bits determine the input source for CLK3.
1:0	CLK3_IDRV[1:0]	CLK3 Output Rise and Fall time / Drive Strength Control. 00: 2 mA 01: 4 mA 10: 6 mA 11: 8 mA

Si5351A/B/C

Register 20. CLK4 Control

Bit	D7	D6	D5	D4	D3	D2	D1	D0
Name	CLK4_PDN	MS4_INT	MS4_SRC	CLK4_INV	CLK4_SRC[1:0]		CLK4_IDRV[1:0]	
Type	R/W	R/W	R/W	R/W	R/W		R/W	

Reset value = 0000 0000

Bit	Name	Function
7	CLK4_PDN	<p>Clock 4 Power Down.</p> <p>This bit allows powering down the CLK4 output driver to conserve power when the output is unused.</p> <p>0: CLK4 is powered up. 1: CLK4 is powered down.</p>
6	MS4_INT	<p>MultiSynth 4 Integer Mode.</p> <p>This bit can be used to force MS4 into Integer mode to improve jitter performance. Note that the fractional mode is necessary when a delay offset is specified for CLK4.</p> <p>0: MS4 operates in fractional division mode. 1: MS4 operates in integer mode.</p>
5	MS4_SRC	<p>MultiSynth Source Select for CLK4.</p> <p>0: Select PLLA as the source for MultiSynth0. 1: Select PLLB (Si5351A/C only) or VCXO (Si5351B only) MultiSynth0.</p>
4	CLK4_INV	<p>Output Clock 4 Invert.</p> <p>0: Output Clock 4 is not inverted. 1: Output Clock 4 is inverted.</p>
3:2	CLK4_SRC[1:0]	<p>Output Clock 4 Input Source.</p> <p>These bits determine the input source for CLK4.</p> <p>00: Select the XTAL as the clock source for CLK4. This option by-passes both synthesis stages (PLL/VCXO & MultiSynth) and connects CLK4 directly to the oscillator which generates an output frequency determined by the XTAL frequency.</p> <p>01: Select CLKIN as the clock source for CLK4. This by-passes both synthesis stages (PLL/VCXO & MultiSynth) and connects CLK4 directly to the CLKIN input. This essentially creates a buffered output of the CLKIN input.</p> <p>10: Reserved. Do not select this option. 11: Select MultiSynth 0 as the source for CLK4. Select this option when using the Si5351 to generate free-running or synchronous clocks.</p>
1:0	CLK4_IDRV[1:0]	<p>CLK4 Output Rise and Fall time / Drive Strength Control.</p> <p>00: 2 mA 01: 4 mA 10: 6 mA 11: 8 mA</p>

Register 21. CLK5 Control

Bit	D7	D6	D5	D4	D3	D2	D1	D0
Name	CLK5_PDN	MS5_INT	MS5_SRC	CLK5_INV	CLK5_SRC[1:0]		CLK5_IDRV[1:0]	
Type	R/W	R/W	R/W	R/W	R/W		R/W	

Reset value = 0000 0000

Bit	Name	Function
7	CLK5_PDN	<p>Clock 5 Power Down.</p> <p>This bit allows powering down the CLK5 output driver to conserve power when the output is unused.</p> <p>0: CLK4 is powered up. 1: CLK4 is powered down.</p>
6	MS5_INT	<p>MultiSynth 5 Integer Mode.</p> <p>This bit can be used to force MS5 into Integer mode to improve jitter performance. Note that the fractional mode is necessary when a delay offset is specified for CLK4.</p> <p>0: MS5 operates in fractional division mode. 1: MS5 operates in integer mode.</p>
5	MS5_SRC	<p>MultiSynth Source Select for CLK5.</p> <p>0: Select PLLA as the source for MultiSynth0. 1: Select PLLB (Si5351A/C only) or VCXO (Si5351B only) MultiSynth0.</p>
4	CLK5_INV	<p>Output Clock 5 Invert.</p> <p>0: Output Clock 5 is not inverted. 1: Output Clock 5 is inverted.</p>
3:2	CLK5_SRC[1:0]	<p>Output Clock 5 Input Source.</p> <p>These bits determine the input source for CLK5.</p> <p>00: Select the XTAL as the clock source for CLK5. This option by-passes both synthesis stages (PLL/VCXO & MultiSynth) and connects CLK5 directly to the oscillator which generates an output frequency determined by the XTAL frequency.</p> <p>01: Select CLKIN as the clock source for CLK5. This by-passes both synthesis stages (PLL/VCXO & MultiSynth) and connects CLK5 directly to the CLKIN input. This essentially creates a buffered output of the CLKIN input.</p> <p>10: Reserved. Do not select this option. 11: Select MultiSynth 0 as the source for CLK5. Select this option when using the Si5351 to generate free-running or synchronous clocks.</p>
1:0	CLK5_IDRV[1:0]	<p>CLK5 Output Rise and Fall time / Drive Strength Control.</p> <p>00: 2 mA 01: 4 mA 10: 6 mA 11: 8 mA</p>

Si5351A/B/C

Register 22. CLK6 Control

Bit	D7	D6	D5	D4	D3	D2	D1	D0
Name	CLK6_PDN	FBA_INT	MS6_SRC	CLK6_INV	CLK6_SRC[1:0]		CLK6_IDRV[1:0]	
Type	R/W	R/W	R/W	R/W	R/W		R/W	

Reset value = 0000 0000

Bit	Name	Function
7	CLK6_PDN	<p>Clock 7 Power Down.</p> <p>This bit allows powering down the CLK6 output driver to conserve power when the output is unused.</p> <p>0: CLK6 is powered up.</p> <p>1: CLK6 is powered down.</p>
6	FBA_INT	<p>FBA MultiSynth Integer Mode.</p> <p>Set this bit according to ClockBuilder Desktop generated register map file.</p>
5	MS6_SRC	<p>MultiSynth Source Select for CLK6.</p> <p>0: Select PLLA as the source for MultiSynth0.</p> <p>1: Select PLLB (Si5351A/C only) or VCXO (Si5351B only) MultiSynth0.</p>
4	CLK6_INV	<p>Output Clock 6 Invert.</p> <p>0: Output Clock 6 is not inverted.</p> <p>1: Output Clock 6 is inverted.</p>
3:2	CLK6_SRC[1:0]	<p>Output Clock 0 Input Source.</p> <p>These bits determine the input source for CLK6.</p> <p>00: Select the XTAL as the clock source for CLK6. This option by-passes both synthesis stages (PLL/VCXO & MultiSynth) and connects CLK6 directly to the oscillator which generates an output frequency determined by the XTAL frequency.</p> <p>01: Select CLKIN as the clock source for CLK6. This by-passes both synthesis stages (PLL/VCXO & MultiSynth) and connects CLK6 directly to the CLKIN input. This essentially creates a buffered output of the CLKIN input.</p> <p>10: Reserved. Do not select this option.</p> <p>11: Select MultiSynth 0 as the source for CLK6. Select this option when using the Si5351 to generate free-running or synchronous clocks.</p>
1:0	CLK6_IDRV[1:0]	<p>CLK6 Output Rise and Fall time / Drive Strength Control.</p> <p>00: 2 mA</p> <p>01: 4 mA</p> <p>10: 6 mA</p> <p>11: 8 mA</p>

Register 23. CLK7 Control

Bit	D7	D6	D5	D4	D3	D2	D1	D0
Name	CLK7_PDN	FBB_INT	MS7_SRC	CLK7_INV	CLK7_SRC[1:0]		CLK7_IDRV[1:0]	
Type	R/W	R/W	R/W	R/W	R/W		R/W	

Reset value = 0000 0000

Bit	Name	Function
7	CLK7_PDN	Clock 7 Power Down. This bit allows powering down the CLK7 output driver to conserve power when the output is unused. 0: CLK7 is powered up. 1: CLK7 is powered down.
6	FBB_INT	FBB MultiSynth Integer Mode. Set this bit according to ClockBuilder Desktop generated register map file.
5	MS7_SRC	MultiSynth Source Select for CLK7. 0: Select PLLA as the source for MultiSynth0. 1: Select PLLB (Si5351A/C only) or VCXO (Si5351B only) MultiSynth0.
4	CLK7_INV	Output Clock 7 Invert. 0: Output Clock 7 is not inverted. 1: Output Clock 7 is inverted.
3:2	CLK7_SRC[1:0]	Output Clock 0 Input Source. These bits determine the input source for CLK7. 00: Select the XTAL as the clock source for CLK7. This option by-passes both synthesis stages (PLL/VCXO & MultiSynth) and connects CLK7 directly to the oscillator which generates an output frequency determined by the XTAL frequency. 01: Select CLKIN as the clock source for CLK7. This by-passes both synthesis stages (PLL/VCXO & MultiSynth) and connects CLK7 directly to the CLKIN input. This essentially creates a buffered output of the CLKIN input. 10: Reserved. Do not select this option. 11: Select MultiSynth 0 as the source for CLK7. Select this option when using the Si5351 to generate free-running or synchronous clocks.
1:0	CLK7_IDRV[1:0]	CLK7 Output Rise and Fall time / Drive Strength Control. 00: 2 mA 01: 4 mA 10: 6 mA 11: 8 mA

Register 24. CLK3–0 Disable State

Bit	D7	D6	D5	D4	D3	D2	D1	D0
Name	CLK3_DIS_STATE		CLK2_DIS_STATE		CLK1_DIS_STATE		CLK0_DIS_STATE	
Type	R/W		R/W		R/W		R/W	

Reset value = 0000 0000

Bit	Name	Function
7:0	CLKx_DIS_STATE	<p>Clock x Disable State.</p> <p>Where x = 0, 1, 2, 3. These 2 bits determine the state of the CLKx output when disabled. Individual output clocks can be disabled using register <i>Output Enable Control</i> located at address 3. Outputs are also disabled using the OEB pin.</p> <p>00: CLKx is set to a LOW state when disabled.</p> <p>01: CLKx is set to a HIGH state when disabled.</p> <p>10: CLKx is set to a HIGH IMPEDANCE state when disabled.</p> <p>11: CLKx is NEVER DISABLED.</p>

Register 25. CLK7–4 Disable State

Bit	D7	D6	D5	D4	D3	D2	D1	D0
Name	CLK7_DIS_STATE		CLK6_DIS_STATE		CLK5_DIS_STATE		CLK4_DIS_STATE	
Type	R/W		R/W		R/W		R/W	

Reset value = 0000 0000

Bit	Name	Function
7:0	CLKx_DIS_STATE	<p>Clock x Disable State.</p> <p>Where x = 4, 5, 6, 7. These 2 bits determine the state of the CLKx output when disabled. Individual output clocks can be disabled using register <i>Output Enable Control</i> located at address 3. Outputs are also disabled using the OEB pin.</p> <p>00: CLKx is set to a LOW state when disabled.</p> <p>01: CLKx is set to a HIGH state when disabled.</p> <p>10: CLKx is set to a HIGH IMPEDANCE state when disabled.</p> <p>11: CLKx is NEVER DISABLED.</p>

Register 42. Multisynth0 Parameters

Bit	D7	D6	D5	D4	D3	D2	D1	D0
Name	MS0_P3[15:8]							
Type	R/W							

Reset value = xxxx xxxx

Bit	Name	Function
7:0	MS0_P3[15:8]	Multisynth0 Parameter 3. This 20-bit number is an encoded representation of the denominator for the fractional part of the MultiSynth0 Divider.

Register 43. Multisynth0 Parameters

Bit	D7	D6	D5	D4	D3	D2	D1	D0
Name	MS0_P3[7:0]							
Type	R/W							

Reset value = xxxx xxxx

Bit	Name	Function
7:0	MS0_P3[7:0]	Multisynth0 Parameter 3. This 20-bit number is an encoded representation of the denominator for the fractional part of the MultiSynth0 Divider.

Si5351A/B/C

Register 44. Multisynth0 Parameters

Bit	D7	D6	D5	D4	D3	D2	D1	D0
Name		R0_DIV[2:0]					MS0_P1[17:16]	
Type	R/W	R/W			R/W	R/W	R/W	

Reset value = xxxx xxxx

Bit	Name	Function
7	Unused	
6:4	R0_DIV[2:0]	R0 Output Divider. 000b: Divide by 1 001b: Divide by 2 010b: Divide by 4 011b: Divide by 8 100b: Divide by 16 101b: Divide by 32 110b: Divide by 64 111b: Divide by 128
3:2	Reserved	
1:0	MS0_P1[17:16]	Multisynth0 Parameter 1. This 18-bit number is an encoded representation of the integer part of the MultiSynth0 divider.

Register 45. Multisynth0 Parameters

Bit	D7	D6	D5	D4	D3	D2	D1	D0
Name	MS0_P1[15:8]							
Type	R/W							

Reset value = xxxx xxxx

Bit	Name	Function
7:0	MS0_P1[15:8]	Multisynth0 Parameter 1. This 18-bit number is an encoded representation of the integer part of the MultiSynth1 divider.

Register 46. Multisynth0 Parameters

Bit	D7	D6	D5	D4	D3	D2	D1	D0
Name	MS0_P1[7:0]							
Type	R/W							

Reset value = xxxx xxxx

Bit	Name	Function
7:0	MS0_P1[7:0]	Multisynth0 Parameter 1. This 18-bit number is an encoded representation of the integer part of the MultiSynth1 divider.

Register 47. Multisynth0 Parameters

Bit	D7	D6	D5	D4	D3	D2	D1	D0
Name	MS0_P3[19:16]				MS0_P2[19:16]			
Type	R/W				R/W			

Reset value = xxxx xxxx

Bit	Name	Function
7:4	MS0_P3[19:16]	Multisynth0 Parameter 3. This 20-bit number is an encoded representation of the denominator for the fractional part of the MultiSynth0 Divider
3:0	MS0_P2[19:16]	Multisynth0 Parameter 2. This 20-bit number is an encoded representation of the numerator for the fractional part of the MultiSynth1 Divider.

Register 48. Multisynth0 Parameters

Bit	D7	D6	D5	D4	D3	D2	D1	D0
Name	MS0_P2[15:8]							
Type	R/W							

Reset value = xxxx xxxx

Bit	Name	Function
7:0	MS0_P2[15:8]	Multisynth0 Parameter 2. This 20-bit number is an encoded representation of the numerator for the fractional part of the MultiSynth1 Divider.

Si5351A/B/C

Register 49. Multisynth0 Parameters

Bit	D7	D6	D5	D4	D3	D2	D1	D0
Name	MS0_P2[7:0]							
Type	R/W							

Reset value = xxxx xxxx

Bit	Name	Function
7:0	MS0_P2[7:0]	Multisynth0 Parameter 2. This 20-bit number is an encoded representation of the numerator for the fractional part of the MultiSynth1 Divider.

Register 50. Multisynth1 Parameters

Bit	D7	D6	D5	D4	D3	D2	D1	D0
Name	MS1_P3[15:8]							
Type	R/W							

Reset value = xxxx xxxx

Bit	Name	Function
7:0	MS1_P3[15:8]	Multisynth1 Parameter 3. This 20-bit number is an encoded representation of the denominator for the fractional part of the MultiSynth1 Divider.

Register 51. Multisynth1 Parameters

Bit	D7	D6	D5	D4	D3	D2	D1	D0
Name	MS1_P3[7:0]							
Type	R/W							

Reset value = xxxx xxxx

Bit	Name	Function
7:0	MS1_P3[7:0]	Multisynth1 Parameter 3. This 20-bit number is an encoded representation of the denominator for the fractional part of the MultiSynth1 Divider.

Register 52. Multisynth1 Parameters

Bit	D7	D6	D5	D4	D3	D2	D1	D0
Name	R1_DIV[2:0]						MS1_P1[17:16]	
Type	R/W	R/W			R/W	R/W	R/W	

Reset value = xxxx xxxx

Bit	Name	Function
7	Unused	
6:4	R1_DIV[2:0]	R1 Output Divider. 000b: Divide by 1 001b: Divide by 2 010b: Divide by 4 011b: Divide by 8 100b: Divide by 16 101b: Divide by 32 110b: Divide by 64 111b: Divide by 128
3:2	Reserved	
1:0	MS1_P1[17:16]	Multisynth1 Parameter 1. This 18-bit number is an encoded representation of the integer part of the MultiSynth1 divider.

Register 53. Multisynth1 Parameters

Bit	D7	D6	D5	D4	D3	D2	D1	D0
Name	MS1_P1[15:8]							
Type	R/W							

Reset value = xxxx xxxx

Bit	Name	Function
7:0	MS1_P1[15:8]	Multisynth1 Parameter 1. This 18-bit number is an encoded representation of the integer part of the MultiSynth1 divider.

Si5351A/B/C

Register 54. Multisynth1 Parameters

Bit	D7	D6	D5	D4	D3	D2	D1	D0
Name	MS1_P1[7:0]							
Type	R/W							

Reset value = xxxx xxxx

Bit	Name	Function
7:0	MS1_P1[7:0]	Multisynth1 Parameter 1. This 18-bit number is an encoded representation of the integer part of the MultiSynth1 divider.

Register 55. Multisynth1 Parameters

Bit	D7	D6	D5	D4	D3	D2	D1	D0
Name	MS1_P3[19:16]				MS1_P2[19:16]			
Type	R/W				R/W			

Reset value = xxxx xxxx

Bit	Name	Function
7:4	MS1_P3[19:16]	Multisynth1 Parameter 3. This 20-bit number is an encoded representation of the denominator for the fractional part of the Multisynth1 Divider
3:0	MS1_P2[19:16]	Multisynth1 Parameter 2. This 20-bit number is an encoded representation of the numerator for the fractional part of the MultiSynth1 Divider.

Register 56. Multisynth1 Parameters

Bit	D7	D6	D5	D4	D3	D2	D1	D0
Name	MS1_P2[15:8]							
Type	R/W							

Reset value = xxxx xxxx

Bit	Name	Function
7:0	MS1_P2[15:8]	Multisynth1 Parameter 2. This 20-bit number is an encoded representation of the numerator for the fractional part of the MultiSynth1 divider.

Register 57. Multisynth1 Parameters

Bit	D7	D6	D5	D4	D3	D2	D1	D0
Name	MS1_P2[7:0]							
Type	R/W							

Reset value = xxxx xxxx

Bit	Name	Function
7:0	MS1_P2[7:0]	Multisynth1 Parameter 2. This 20-bit number is an encoded representation of the numerator for the fractional part of the MultiSynth1 divider.

Register 58. Multisynth1 Parameters

Bit	D7	D6	D5	D4	D3	D2	D1	D0
Name	MS1_P3[15:8]							
Type	R/W							

Reset value = xxxx xxxx

Bit	Name	Function
7:0	MS1_P3[15:8]	Multisynth1 Parameter 3. This 20-bit number is an encoded representation of the denominator for the fractional part of the MultiSynth1 divider.

Register 59. Multisynth1 Parameters

Bit	D7	D6	D5	D4	D3	D2	D1	D0
Name	MS1_P3[7:0]							
Type	R/W							

Reset value = xxxx xxxx

Bit	Name	Function
7:0	MS1_P3[7:0]	Multisynth1 Parameter 3. This 20-bit number is an encoded representation of the denominator for the fractional part of the MultiSynth1 divider.

Si5351A/B/C

Register 60. Multisynth2 Parameters

Bit	D7	D6	D5	D4	D3	D2	D1	D0
Name	R2_DIV[2:0]							MS2_P1[17:16]
Type	R/W	R/W			R/W	R/W	R/W	

Reset value = xxxx xxxx

Bit	Name	Function
7	Unused	
6:4	R2_DIV[2:0]	R2 Output Divider. 000b: Divide by 1 001b: Divide by 2 010b: Divide by 4 011b: Divide by 8 100b: Divide by 16 101b: Divide by 32 110b: Divide by 64 111b: Divide by 128
3:2	Reserved	
1:0	MS2_P1[17:16]	Multisynth2 Parameter 1. This 18-bit number is an encoded representation of the integer part of the Multisynth2 divider.

Register 61. Multisynth2 Parameters

Bit	D7	D6	D5	D4	D3	D2	D1	D0
Name	MS2_P1[15:8]							
Type	R/W							

Reset value = xxxx xxxx

Bit	Name	Function
7:0	MS2_P1[15:8]	Multisynth2 Parameter 1. This 18-bit number is an encoded representation of the integer part of the Multisynth2 divider.

Register 62. Multisynth2 Parameters

Bit	D7	D6	D5	D4	D3	D2	D1	D0
Name	MS2_P1[7:0]							
Type	R/W							

Reset value = xxxx xxxx

Bit	Name	Function
7:0	MS2_P1[7:0]	Multisynth2 Parameter 1. This 18-bit number is an encoded representation of the integer part of the Multisynth2 divider.

Register 63. Multisynth2 Parameters

Bit	D7	D6	D5	D4	D3	D2	D1	D0
Name	MS2_P3[19:16]				MS2_P2[19:16]			
Type	R/W				R/W			

Reset value = xxxx xxxx

Bit	Name	Function
7:4	MS2_P3[19:16]	Multisynth2 Parameter 3. This 20-bit number is an encoded representation of the denominator for the fractional part of the Multisynth2 divider
3:0	MS2_P2[19:16]	Multisynth2 Parameter 2. This 20-bit number is an encoded representation of the numerator for the fractional part of the MultiSynth2 divider.

Register 64. Multisynth2 Parameters

Bit	D7	D6	D5	D4	D3	D2	D1	D0
Name	MS2_P2[15:8]							
Type	R/W							

Reset value = xxxx xxxx

Bit	Name	Function
7:0	MS2_P2[15:8]	Multisynth2 Parameter 2. This 20-bit number is an encoded representation of the numerator for the fractional part of the Multisynth2 divider.

Si5351A/B/C

Register 65. Multisynth2 Parameters

Bit	D7	D6	D5	D4	D3	D2	D1	D0
Name	MS2_P2[7:0]							
Type	R/W							

Reset value = xxxx xxxx

Bit	Name	Function
7:0	MS2_P2[7:0]	Multisynth2 Parameter 2. This 20-bit number is an encoded representation of the numerator for the fractional part of the Multisynth2 divider.

Register 66. Multisynth3 Parameters

Bit	D7	D6	D5	D4	D3	D2	D1	D0
Name	MS3_P3[15:8]							
Type	R/W							

Reset value = xxxx xxxx

Bit	Name	Function
7:0	MS3_P3[15:8]	Multisynth3 Parameter 3. This 20-bit number is an encoded representation of the denominator for the fractional part of the Multisynth3 divider.

Register 67. Multisynth3 Parameters

Bit	D7	D6	D5	D4	D3	D2	D1	D0
Name	MS3_P3[7:0]							
Type	R/W							

Reset value = xxxx xxxx

Bit	Name	Function
7:0	MS3_P3[7:0]	Multisynth3 Parameter 3. This 20-bit number is an encoded representation of the denominator for the fractional part of the Multisynth3 divider.

Register 68. Multisynth3 Parameters

Bit	D7	D6	D5	D4	D3	D2	D1	D0
Name	R3_DIV[2:0]							MS3_P1[17:16]
Type	R/W	R/W			R/W	R/W	R/W	

Reset value = xxxx xxxx

Bit	Name	Function
7	Unused	
6:4	R3_DIV[2:0]	R3 Output Divider. 000b: Divide by 1 001b: Divide by 2 010b: Divide by 4 011b: Divide by 8 100b: Divide by 16 101b: Divide by 32 110b: Divide by 64 111b: Divide by 128
3:2	Reserved	
1:0	MS3_P1[17:16]	Multisynth3 Parameter 1. This 18-bit number is an encoded representation of the integer part of the Multisynth3 divider.

Register 69. Multisynth3 Parameters

Bit	D7	D6	D5	D4	D3	D2	D1	D0
Name	MS3_P1[15:8]							
Type	R/W							

Reset value = xxxx xxxx

Bit	Name	Function
7:0	MS3_P1[15:8]	Multisynth3 Parameter 1. This 18-bit number is an encoded representation of the integer part of the Multisynth3 divider.

Si5351A/B/C

Register 70. Multisynth3 Parameters

Bit	D7	D6	D5	D4	D3	D2	D1	D0
Name	MS3_P1[7:0]							
Type	R/W							

Reset value = xxxx xxxx

Bit	Name	Function
7:0	MS3_P1[7:0]	Multisynth3 Parameter 1. This 18-bit number is an encoded representation of the integer part of the Multisynth3 divider.

Register 71. Multisynth3 Parameters

Bit	D7	D6	D5	D4	D3	D2	D1	D0
Name	MS3_P3[19:16]				MS3_P2[19:16]			
Type	R/W				R/W			

Reset value = xxxx xxxx

Bit	Name	Function
7:4	MS3_P3[19:16]	Multisynth3 Parameter 3. This 20-bit number is an encoded representation of the denominator for the fractional part of the Multisynth3 divider
3:0	MS3_P2[19:16]	Multisynth3 Parameter 2. This 20-bit number is an encoded representation of the numerator for the fractional part of the MultiSynth3 divider.

Register 72. Multisynth3 Parameters

Bit	D7	D6	D5	D4	D3	D2	D1	D0
Name	MS3_P2[15:8]							
Type	R/W							

Reset value = xxxx xxxx

Bit	Name	Function
7:0	MS3_P2[15:8]	Multisynth3 Parameter 2. This 20-bit number is an encoded representation of the numerator for the fractional part of the Multisynth3 divider.

Register 73. Multisynth3 Parameters

Bit	D7	D6	D5	D4	D3	D2	D1	D0
Name	MS3_P2[7:0]							
Type	R/W							

Reset value = xxxx xxxx

Bit	Name	Function
7:0	MS3_P2[7:0]	Multisynth3 Parameter 2. This 20-bit number is an encoded representation of the numerator for the fractional part of the Multisynth3 divider.

Register 74. Multisynth4 Parameters

Bit	D7	D6	D5	D4	D3	D2	D1	D0
Name	MS4_P3[15:8]							
Type	R/W							

Reset value = xxxx xxxx

Bit	Name	Function
7:0	MS4_P3[15:8]	Multisynth4 Parameter 3. This 20-bit number is an encoded representation of the denominator for the fractional part of the Multisynth4 divider.

Register 75. Multisynth4 Parameters

Bit	D7	D6	D5	D4	D3	D2	D1	D0
Name	MS4_P3[7:0]							
Type	R/W							

Reset value = xxxx xxxx

Bit	Name	Function
7:0	MS4_P3[7:0]	Multisynth4 Parameter 3. This 20-bit number is an encoded representation of the numerator for the fractional part of the Multisynth4 divider.

Si5351A/B/C

Register 76. Multisynth4 Parameters

Bit	D7	D6	D5	D4	D3	D2	D1	D0
Name	R4_DIV[2:0]						MS4_P1[17:16]	
Type	R/W	R/W			R/W	R/W	R/W	

Reset value = xxxx xxxx

Bit	Name	Function
7	Unused	
6:4	R4_DIV[2:0]	R4 Output Divider. 000b: Divide by 1 001b: Divide by 2 010b: Divide by 4 011b: Divide by 8 100b: Divide by 16 101b: Divide by 32 110b: Divide by 64 111b: Divide by 128
3:2	Reserved	
1:0	MS4_P1[17:16]	Multisynth4 Parameter 1. This 18-bit number is an encoded representation of the integer part of the Multisynth4 divider.

Register 77. Multisynth4 Parameters

Bit	D7	D6	D5	D4	D3	D2	D1	D0
Name	MS4_P1[15:8]							
Type	R/W							

Reset value = xxxx xxxx

Bit	Name	Function
7:0	MS4_P1[15:8]	Multisynth4 Parameter 1. This 18-bit number is an encoded representation of the integer part of the Multisynth4 divider.

Register 78. Multisynth4 Parameters

Bit	D7	D6	D5	D4	D3	D2	D1	D0
Name	MS4_P1[7:0]							
Type	R/W							

Reset value = xxxx xxxx

Bit	Name	Function
7:0	MS4_P1[7:0]	Multisynth4 Parameter 1. This 18-bit number is an encoded representation of the integer part of the Multisynth4 divider.

Register 79. Multisynth4 Parameters

Bit	D7	D6	D5	D4	D3	D2	D1	D0
Name	MS4_P3[19:16]				MS4_P2[19:16]			
Type	R/W				R/W			

Reset value = xxxx xxxx

Bit	Name	Function
7:4	MS4_P3[19:16]	Multisynth4 Parameter 3. This 20-bit number is an encoded representation of the denominator for the fractional part of the Multisynth4 divider
3:0	MS4_P2[19:16]	Multisynth4 Parameter 2. This 20-bit number is an encoded representation of the numerator for the fractional part of the MultiSynth4 divider.

Register 80. Multisynth4 Parameters

Bit	D7	D6	D5	D4	D3	D2	D1	D0
Name	MS4_P2[15:8]							
Type	R/W							

Reset value = xxxx xxxx

Bit	Name	Function
7:0	MS4_P2[15:8]	Multisynth4 Parameter 2. This 20-bit number is an encoded representation of the numerator for the fractional part of the Multisynth4 Divider.

Si5351A/B/C

Register 81. Multisynth4 Parameters

Bit	D7	D6	D5	D4	D3	D2	D1	D0
Name	MS4_P2[7:0]							
Type	R/W							

Reset value = xxxx xxxx

Bit	Name	Function
7:0	MS4_P2[7:0]	Multisynth4 Parameter 2. This 20-bit number is an encoded representation of the numerator for the fractional part of the Multisynth4 divider.

Register 82. Multisynth5 Parameters

Bit	D7	D6	D5	D4	D3	D2	D1	D0
Name	MS5_P3[15:8]							
Type	R/W							

Reset value = xxxx xxxx

Bit	Name	Function
7:0	MS5_P3[15:8]	Multisynth5 Parameter 3. This 20-bit number is an encoded representation of the denominator for the fractional part of the Multisynth5 divider.

Register 83. Multisynth5 Parameters

Bit	D7	D6	D5	D4	D3	D2	D1	D0
Name	MS5_P3[7:0]							
Type	R/W							

Reset value = xxxx xxxx

Bit	Name	Function
7:0	MS5_P3[7:0]	Multisynth5 Parameter 3. This 20-bit number is an encoded representation of the denominator for the fractional part of the Multisynth5 divider.

Register 84. Multisynth5 Parameters

Bit	D7	D6	D5	D4	D3	D2	D1	D0
Name	R5_DIV[2:0]						MS5_P1[17:16]	
Type	R/W	R/W			R/W	R/W	R/W	

Reset value = xxxx xxxx

Bit	Name	Function
7	Unused	
6:4	R5_DIV[2:0]	R5 Output Divider. 000b: Divide by 1 001b: Divide by 2 010b: Divide by 4 011b: Divide by 8 100b: Divide by 16 101b: Divide by 32 110b: Divide by 64 111b: Divide by 128
3:2	Reserved	
1:0	MS5_P1[17:16]	Multisynth5 Parameter 1. This 18-bit number is an encoded representation of the integer part of the Multisynth5 divider.

Register 85. Multisynth5 Parameters

Bit	D7	D6	D5	D4	D3	D2	D1	D0
Name	MS5_P1[15:8]							
Type	R/W							

Reset value = xxxx xxxx

Bit	Name	Function
7:0	MS5_P1[15:8]	Multisynth5 Parameter 1. This 18-bit number is an encoded representation of the integer part of the Multisynth5 divider.

Si5351A/B/C

Register 86. Multisynth5 Parameters

Bit	D7	D6	D5	D4	D3	D2	D1	D0
Name	MS5_P1[7:0]							
Type	R/W							

Reset value = xxxx xxxx

Bit	Name	Function
7:0	MS5_P1[7:0]	Multisynth5 Parameter 1. This 18-bit number is an encoded representation of the integer part of the Multisynth5 divider.

Register 87. Multisynth5 Parameters

Bit	D7	D6	D5	D4	D3	D2	D1	D0
Name	MS5_P3[19:16]				MS5_P2[19:16]			
Type	R/W				R/W			

Reset value = xxxx xxxx

Bit	Name	Function
7:4	MS5_P3[19:16]	Multisynth5 Parameter 3. This 20-bit number is an encoded representation of the denominator for the fractional part of the Multisynth5 divider
3:0	MS5_P2[19:16]	Multisynth5 Parameter 2. This 20-bit number is an encoded representation of the numerator for the fractional part of the MultiSynth5 divider.

Register 88. Multisynth5 Parameters

Bit	D7	D6	D5	D4	D3	D2	D1	D0
Name	MS5_P2[15:8]							
Type	R/W							

Reset value = xxxx xxxx

Bit	Name	Function
7:0	MS5_P2[15:8]	Multisynth5 Parameter 2. This 20-bit number is an encoded representation of the numerator for the fractional part of the Multisynth5 Divider.

Register 89. Multisynth5 Parameters

Bit	D7	D6	D5	D4	D3	D2	D1	D0
Name	MS5_P2[7:0]							
Type	R/W							

Reset value = xxxx xxxx

Bit	Name	Function
7:0	MS5_P2[7:0]	Multisynth5 Parameter 2. This 20-bit number is an encoded representation of the numerator for the fractional part of the Multisynth5 Divider.

Register 90. Multisynth6 Parameters

Bit	D7	D6	D5	D4	D3	D2	D1	D0
Name	MS6_P1[7:0]							
Type	R/W							

Reset value = xxxx xxxx

Bit	Name	Function
7:0	MS6_P1[7:0]	Multisynth6 Parameter 1. This 8-bit number is the Multisynth6 divide ratio. Multisynth6 divide ratio can only be even integers greater than or equal to 6. All other divide values are invalid.

Register 91. Multisynth7 Parameters

Bit	D7	D6	D5	D4	D3	D2	D1	D0
Name	MS7_P1[7:0]							
Type	R/W							

Reset value = xxxx xxxx

Bit	Name	Function
7:0	MS7_P1[7:0]	Multisynth7 Parameter 1. This 8-bit number is the Multisynth6 divide ratio. Multisynth6 divide ratio can only be even integers greater than or equal to 6. All other divide values are invalid.

Si5351A/B/C

Register 92. Clock 6 and 7 Output Divider

Bit	D7	D6	D5	D4	D3	D2	D1	D0
Name		R7_DIV[2:0]				R6_DIV[2:0]		
Type	R/W	R/W			R/W	R/W		

Reset value = xxxx xxxx

Bit	Name	Function
7	Reserved	Leave as default.
6:4	R7_DIV[2:0]	R7 Output Divider. 000b: Divide by 1 001b: Divide by 2 010b: Divide by 4 011b: Divide by 8 100b: Divide by 16 101b: Divide by 32 110b: Divide by 64 111b: Divide by 128
3	Reserved	Leave as default.
1:0	R6_DIV[2:0]	R6 Output Divider. 000b: Divide by 1 001b: Divide by 2 010b: Divide by 4 011b: Divide by 8 100b: Divide by 16 101b: Divide by 32 110b: Divide by 64 111b: Divide by 128

Register 165. CLK0 Initial Phase Offset

Bit	D7	D6	D5	D4	D3	D2	D1	D0
Name	CLK0_PHOFF[6:0]							
Type	R/W	R/W	R/W	R/W	R/W	R/W	R/W	R/W

Reset value = 0000 0000

Bit	Name	Function
7	Reserved	Only write 0 to this bit.
6:0	CLK0_PHOFF[6:0]	Clock 0 Initial Phase Offset. CLK0_PHOFF[6:0] is an unsigned integer with one LSB equivalent to a time delay of $T_{vco}/4$, where T_{vco} is the period of the VCO/PLL associated with this output.

Register 166. CLK1 Initial Phase Offset

Bit	D7	D6	D5	D4	D3	D2	D1	D0
Name	CLK1_PHOFF[6:0]							
Type	R/W	R/W	R/W	R/W	R/W	R/W	R/W	R/W

Reset value = 0000 0000

Bit	Name	Function
7	Reserved	Only write 0 to this bit.
6:0	CLK1_PHOFF[6:0]	Clock 1 Initial Phase Offset. CLK1_PHOFF[6:0] is an unsigned integer with one LSB equivalent to a time delay of $T_{vco}/4$, where T_{vco} is the period of the VCO/PLL associated with this output.

Register 167. CLK2 Initial Phase Offset

Bit	D7	D6	D5	D4	D3	D2	D1	D0
Name	CLK2_PHOFF[6:0]							
Type	R/W	R/W	R/W	R/W	R/W	R/W	R/W	R/W

Reset value = 0000 0000

Bit	Name	Function
7	Reserved	Only write 0 to this bit.
6:0	CLK2_PHOFF[6:0]	Clock 2 Initial Phase Offset. CLK2_PHOFF[6:0] is an unsigned integer with one LSB equivalent to a time delay of $T_{vco}/4$, where T_{vco} is the period of the VCO/PLL associated with this output.

Si5351A/B/C

Register 168. CLK3 Initial Phase Offset

Bit	D7	D6	D5	D4	D3	D2	D1	D0
Name	CLK3_PHOFF[6:0]							
Type	R/W	R/W	R/W	R/W	R/W	R/W	R/W	R/W

Reset value = 0000 0000

Bit	Name	Function
7	Reserved	Only write 0 to this bit.
6:0	CLK3_PHOFF[6:0]	Clock 3 Initial Phase Offset. CLK3_PHOFF[6:0] is an unsigned integer with one LSB equivalent to a time delay of $T_{vco}/4$, where T_{vco} is the period of the VCO/PLL associated with this output.

Register 169. CLK4 Initial Phase Offset

Bit	D7	D6	D5	D4	D3	D2	D1	D0
Name	CLK4_PHOFF[6:0]							
Type	R/W	R/W	R/W	R/W	R/W	R/W	R/W	R/W

Reset value = 0000 0000

Bit	Name	Function
7	Reserved	Only write 0 to this bit.
6:0	CLK4_PHOFF[6:0]	Clock 4 Initial Phase Offset. CLK4_PHOFF[6:0] is an unsigned integer with one LSB equivalent to a time delay of $T_{vco}/4$, where T_{vco} is the period of the VCO/PLL associated with this output.

Register 170. CLK5 Initial Phase Offset

Bit	D7	D6	D5	D4	D3	D2	D1	D0
Name	CLK5_PHOFF[6:0]							
Type	R/W	R/W	R/W	R/W	R/W	R/W	R/W	R/W

Reset value = 0000 0000

Bit	Name	Function
7	Reserved	Only write 0 to this bit.
6:0	CLK5_PHOFF[6:0]	Clock 5 Initial Phase Offset. CLK5_PHOFF[6:0] is an unsigned integer with one LSB equivalent to a time delay of $T_{vco}/4$, where T_{vco} is the period of the VCO/PLL associated with this output.

Register 177. PLL Reset

Bit	D7	D6	D5	D4	D3	D2	D1	D0
Name	PLL_B_RST		PLL_A_RST					
Type	R/W	R/W	R/W	R/W	R/W	R/W	R/W	R/W

Reset value = 0000 0000

Bit	Name	Function
7	PLL_B_RST	PLL_B_Reset. Writing a 1 to this bit will reset PLLB. This is a self clearing bit (Si5351A/C only).
6	Reserved	Leave as default.
5	PLL_A_RST	PLL_A_Reset. Writing a 1 to this bit will reset PLLA. This is a self clearing bit.
4:0	Reserved	Leave as default.

Register 183. Crystal Internal Load Capacitance

Bit	D7	D6	D5	D4	D3	D2	D1	D0
Name	XTAL_CL[1:0]							
Type	R/W	R/W	R/W	R/W	R/W	R/W	R/W	R/W

Reset value = 11xx xxxx

Bit	Name	Function
7:6	XTAL_CL[1:0]	Crystal Load Capacitance Selection. These 2 bits determine the internal load capacitance value for the crystal. See "3.1.1. Crystal Inputs (XA, XB)" on page 11. 00: Reserved. Do not select this option. 01: Internal CL = 6 pF. 10: Internal CL = 8 pF. 11: Internal CL = 10 pF (default).
5:0	Reserved	Leave as default.

Si5351A/B/C

9. Si5351A Pin Descriptions (20-Pin QFN, 24-Pin QSOP)

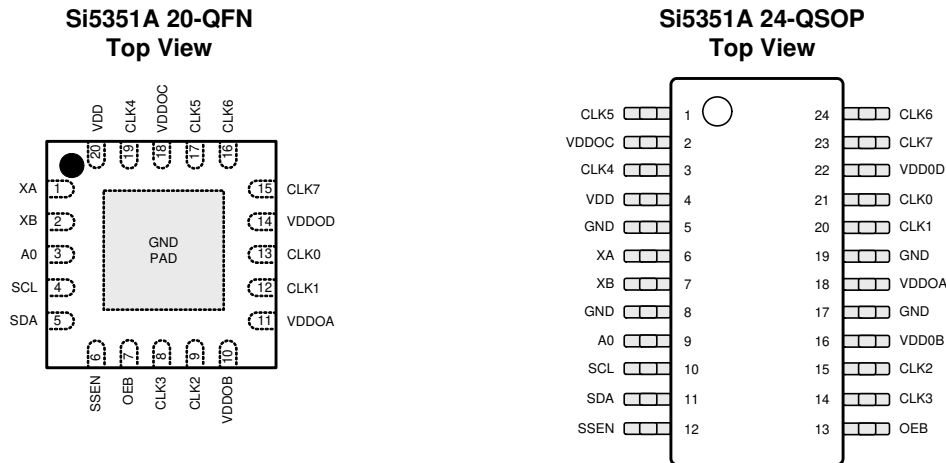

Table 10. Si5351A Pin Descriptions

Pin Name	Pin Number		Pin Type*	Function
	20-QFN	24-QSOP		
XA	1	6	I	Input pin for external crystal.
XB	2	7	I	Input pin for external crystal.
CLK0	13	21	O	Output clock 0.
CLK1	12	20	O	Output clock 1.
CLK2	9	15	O	Output clock 2.
CLK3	8	14	O	Output clock 3.
CLK4	19	3	O	Output clock 4.
CLK5	17	1	O	Output clock 5.
CLK6	16	24	O	Output clock 6.
CLK7	15	23	O	Output clock 7.
A0	3	9	I	I ² C address bit.
SCL	4	10	I	I ² C bus serial clock input. Pull-up to VDD core with 1 kΩ.
SDA	5	11	I/O	I ² C bus serial data input. Pull-up to VDD core with 1 kΩ.
SSEN	6	12	I	Spread spectrum enable. High = enabled, Low = disabled.
OEB	7	13	I	Output driver enable. Low = enabled, High = disabled.
VDD	20	4	P	Core voltage supply pin. See 6.2.
VDDOA	11	18	P	Output voltage supply pin for CLK0 and CLK1. See 6.2.
VDDOB	10	16	P	Output voltage supply pin for CLK2 and CLK3. See 6.2.
VDDOC	18	2	P	Output voltage supply pin for CLK4 and CLK5. See 6.2.
VDDOD	14	22	P	Output voltage supply pin for CLK6 and CLK7. See 6.2.
GND	Center Pad	5, 8, 17, 19	P	Ground. Use multiple vias to ensure a solid path to GND.

1. I = Input, O = Output, P = Power.
 2. Input pins are not internally pulled up.

10. Si5351B Pin Descriptions (20-Pin QFN, 24-Pin QSOP)

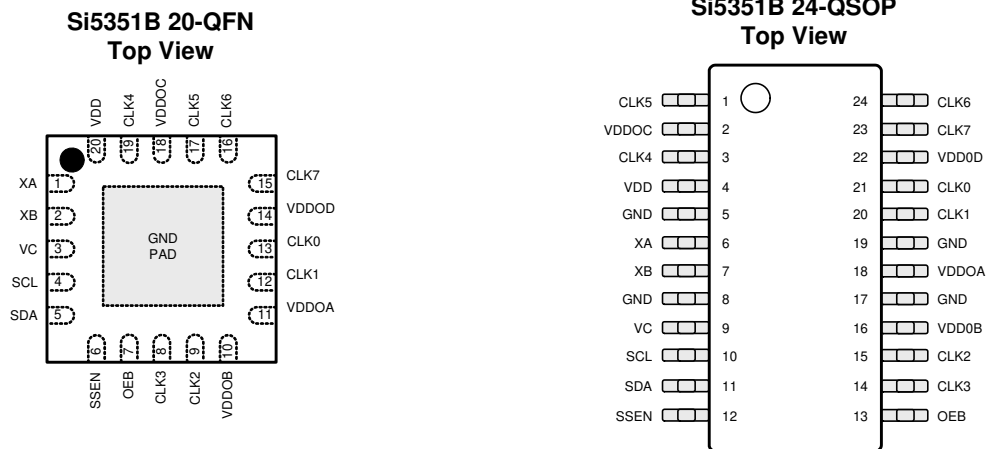

Table 11. Si5351B Pin Descriptions

Pin Name	Pin Number		Pin Type*	Function
	20-QFN	24-QSOP		
XA	1	6	I	Input pin for external crystal
XB	2	7	I	Input pin for external crystal
CLK0	13	21	O	Output clock 0
CLK1	12	20	O	Output clock 1
CLK2	9	15	O	Output clock 2
CLK3	8	14	O	Output clock 3
CLK4	19	3	O	Output clock 4
CLK5	17	1	O	Output clock 5
CLK6	16	24	O	Output clock 6
CLK7	15	23	O	Output clock 7
VC	3	9	I	VCXO control voltage input
SCL	4	10	I	I ² C bus serial clock input. Pull-up to VDD core with 1 k Ω .
SDA	5	11	I/O	I ² C bus serial data input. Pull-up to VDD core with 1 k Ω .
SSEN	6	12	I	Spread spectrum enable. High = enabled, Low = disabled.
OEB	7	13	I	Output driver enable. Low = enabled, High = disabled.
VDD	20	4	P	Core voltage supply pin
VDDOA	11	18	P	Output voltage supply pin for CLK0 and CLK1. See 6.2
VDDOB	10	16	P	Output voltage supply pin for CLK2 and CLK3. See 6.2
VDDOC	18	2	P	Output voltage supply pin for CLK4 and CLK5. See 6.2
VDDOD	14	22	P	Output voltage supply pin for CLK6 and CLK7. See 6.2
GND	Center Pad	5, 8, 17, 19	P	Ground

*Note: I = Input, O = Output, P = Power
 *Note: Input pins are not internally pulled up.

Si5351A/B/C

11. Si5351C Pin Descriptions (20-Pin QFN, 24-Pin QSOP)

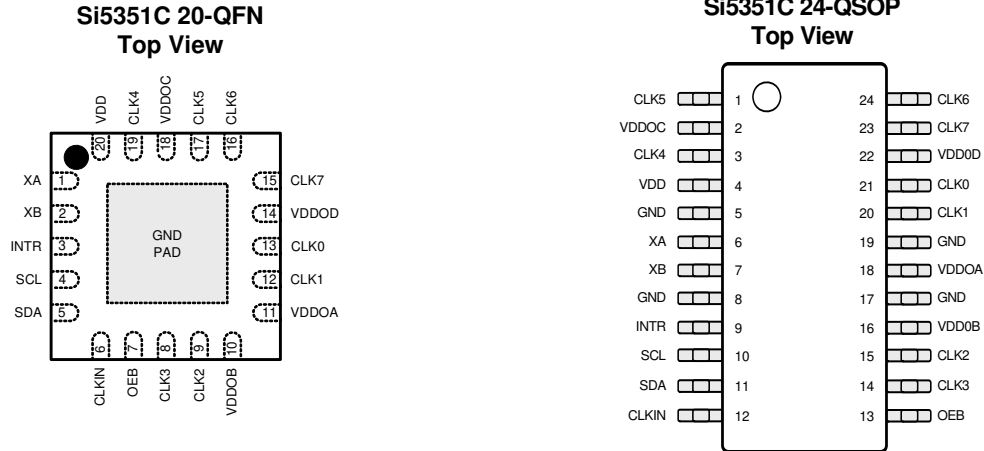

Table 12. Si5351C Pin Descriptions

Pin Name	Pin Number		Pin Type*	Function
	20-QFN	24-QSOP		
XA	1	6	I	Input pin for external crystal.
XB	2	7	I	Input pin for external crystal.
CLK0	13	21	O	Output clock 0.
CLK1	12	20	O	Output clock 1.
CLK2	9	15	O	Output clock 2.
CLK3	8	14	O	Output clock 3.
CLK4	19	3	O	Output clock 4.
CLK5	17	1	O	Output clock 5.
CLK6	16	24	O	Output clock 6.
CLK7	15	23	O	Output clock 7.
INTR	3	9	O	Interrupt pin. Open drain active low output, requires a pull-up resistor greater than 1 kΩ.
SCL	4	10	I	I ² C bus serial clock input. Pull-up to VDD core with 1 kΩ.
SDA	5	11	I/O	I ² C bus serial data input. Pull-up to VDD core with 1 kΩ.
CLKIN	6	12	I	PLL clock input.
OEB	7	13	I	Output driver enable. Low = enabled, High = disabled.
VDD	20	4	P	Core voltage supply pin
VDDOA	11	18	P	Output voltage supply pin for CLK0 and CLK1. See 6.2
VDDOB	10	16	P	Output voltage supply pin for CLK2 and CLK3. See 6.2
VDDOC	18	2	P	Output voltage supply pin for CLK4 and CLK5. See 6.2
VDDOD	14	22	P	Output voltage supply pin for CLK6 and CLK7. See 6.2
GND	Center Pad	5, 8, 17, 19	P	Ground.

Notes:

1. I = Input, O = Output, P = Power.
2. Input pins are not internally pulled up.

12. Si5351A Pin Descriptions (10-Pin MSOP)

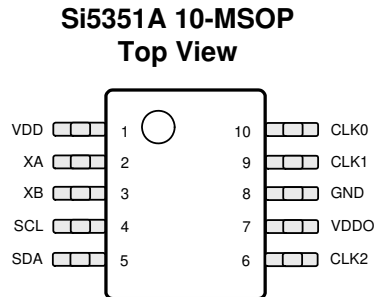

Table 13. Si5351A 10-MSOP Pin Descriptions

Pin Name	Pin Number	Pin Type*	Function
	10-MSOP		
XA	2	I	Input pin for external crystal.
XB	3	I	Input pin for external crystal.
CLK0	10	O	Output clock 0.
CLK1	9	O	Output clock 1.
CLK2	6	O	Output clock 2.
SCL	4	I	Serial clock input for the I ² C bus. This pin must be pulled-up using a pull-up resistor of at least 1 k Ω .
SDA	5	I/O	Serial data input for the I ² C bus. This pin must be pulled-up using a pull-up resistor of at least 1 k Ω .
VDD	1	P	Core voltage supply pin.
VDDO	7	P	Output voltage supply pin for CLK0, CLK1, and CLK2. See "6.2. Power Supply Sequencing" on page 21.
GND	8	P	Ground.

*Note: I = Input, O = Output, P = Power

13. Ordering Information

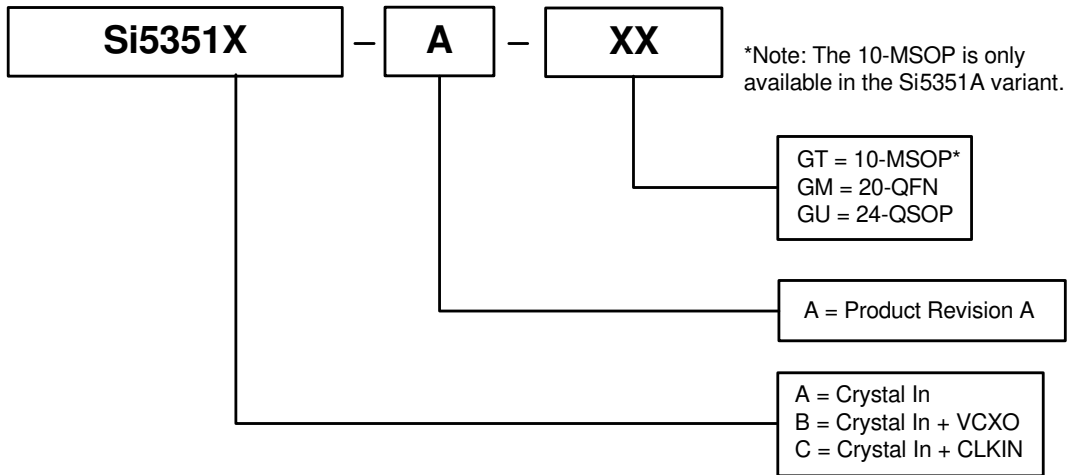

Figure 19. Device Part Numbers

An evaluation kit containing ClockBuilder Desktop software and hardware enable easy evaluation of the Si5351A/B/C. The orderable part numbers for the evaluation kits are provided in Figure 20.

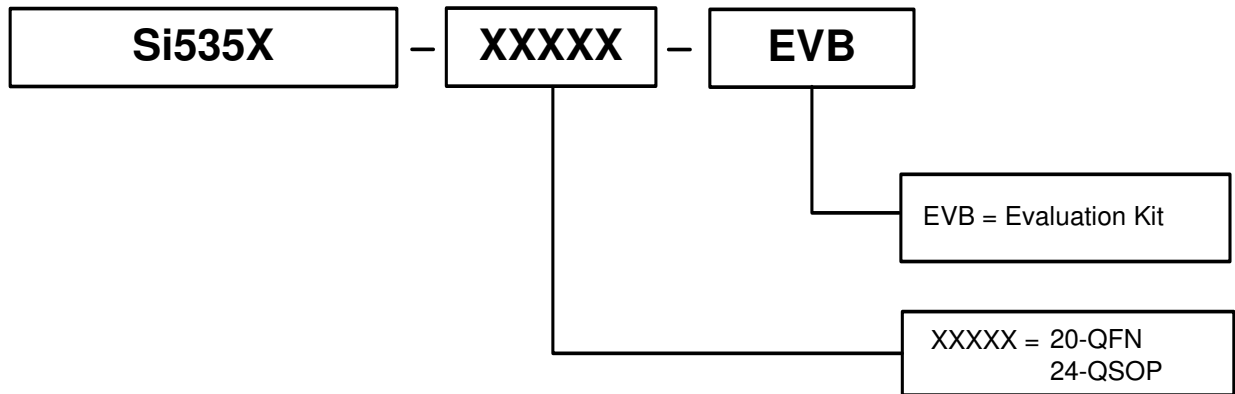

Figure 20. Si5351A/B/C Evaluation Kit

14. Package Outline (24-Pin QSOP)

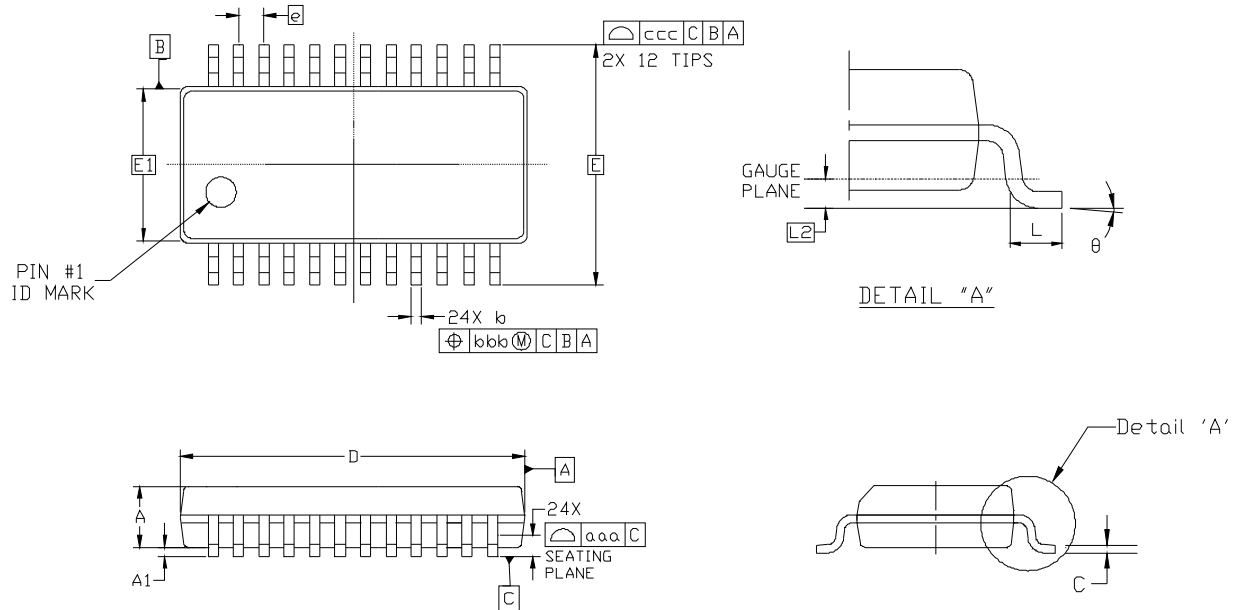

Table 14. 24-QSOP Package Dimensions

Dimension	Min	Nom	Max
A	—	—	1.75
A1	0.10	—	0.25
b	0.19	—	0.30
c	0.15	—	0.25
D	8.55	8.65	8.75
E	6.00 BSC		
E1	3.81	3.90	3.99
e	0.635 BSC		
L	0.40	—	1.27
L2	0.25 BSC		
q	0	—	8
aaa	0.10		
bbb	0.17		
ccc	0.10		

Notes:

1. All dimensions shown are in millimeters (mm) unless otherwise noted.
2. Dimensioning and Tolerancing per ANSI Y14.5M-1994.
3. This drawing conforms to the JEDEC Solid State Outline MO-137, Variation C
4. Recommended card reflow profile is per the JEDEC/IPC J-STD-020 specification for Small Body Components.

15. Package Outline (20-Pin QFN)

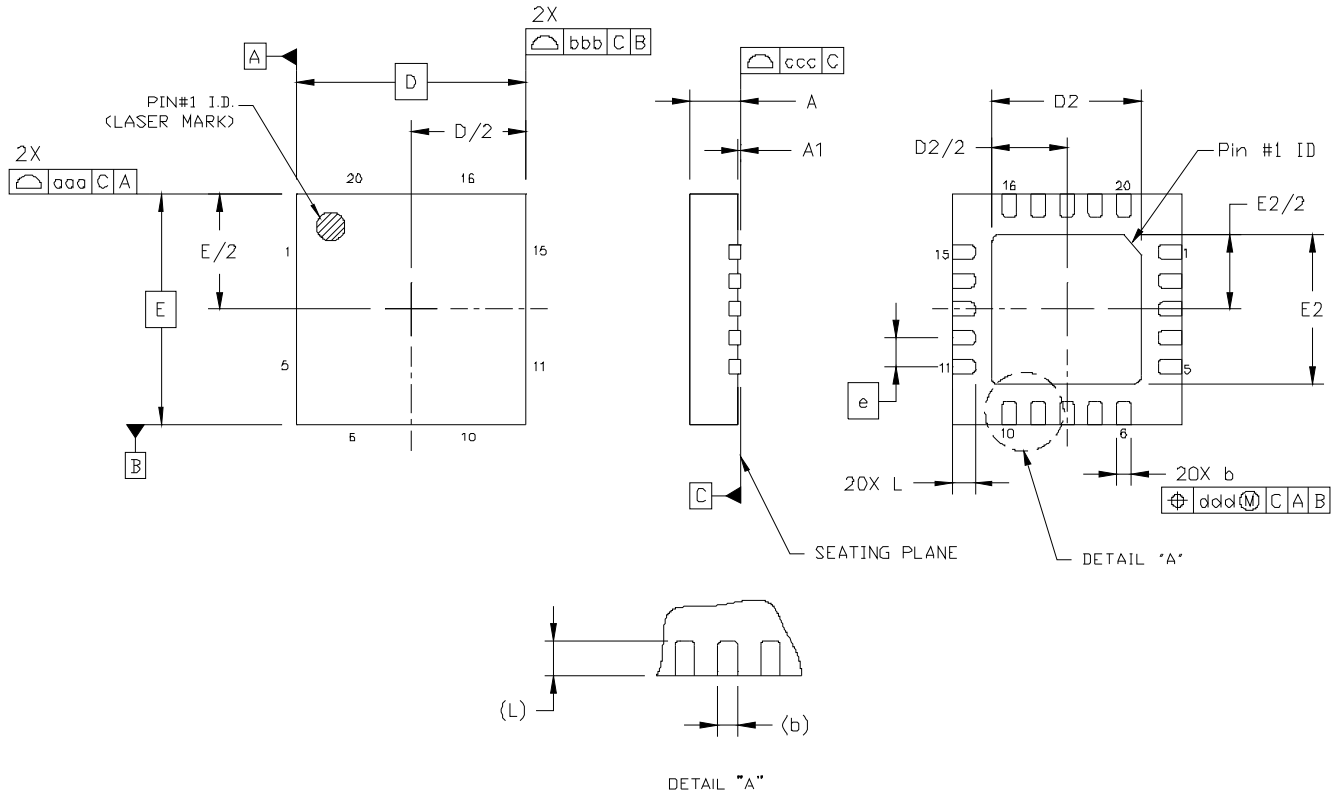

Table 15. Package Dimensions

Dimension	Min	Nom	Max
A	0.80	0.85	0.90
A1	0.00	0.02	0.05
b	0.18	0.25	0.30
D	4.00 BSC		
D2	2.65	2.70	2.75
e	0.50 BSC		
E	4.00 BSC		
E2	2.65	2.70	2.75
L	0.30	0.40	0.50
aaa			0.10
bbb			0.10
ccc			0.08
ddd			0.10
eee			0.10

Notes:

1. All dimensions shown are in millimeters (mm) unless otherwise noted.
2. Dimensioning and Tolerancing per ANSI Y14.5M-1994.
3. This drawing conforms to the JEDEC Outline MO-220, variation VGGD-8.
4. Recommended card reflow profile is per the JEDEC/IPC J-STD-020 specification for Small Body Components.

16. Package Outline (10-Pin MSOP)

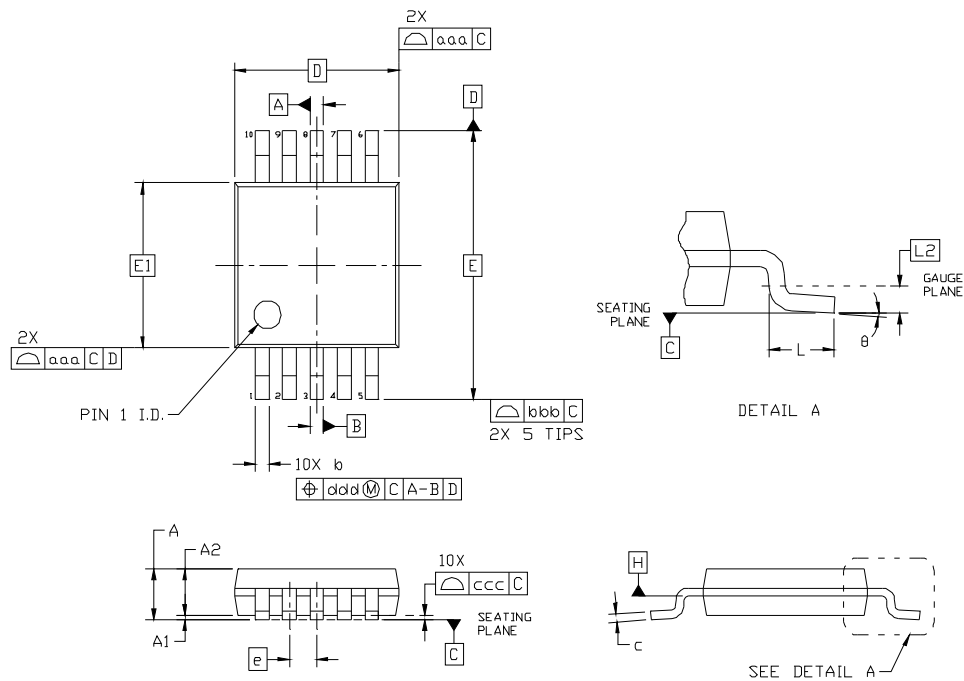

Table 16. 24-QSOP Package Dimensions

Dimension	Min	Nom	Max
A	—	—	1.10
A1	0.00	—	0.15
A2	0.75	0.85	0.95
b	0.17	—	0.33
c	0.08	—	0.23
D	3.00 BSC		
E	4.90 BSC		
E1	3.00 BSC		
e	0.50 BSC		
L	0.40	0.60	0.80
L2	0.25 BSC		
q	0	—	8
aaa	—	—	0.20
bbb	—	—	0.25
ccc	—	—	0.10
ddd	—	—	0.08

Notes:

1. All dimensions shown are in millimeters (mm) unless otherwise noted.
2. Dimensioning and Tolerancing per ANSI Y14.5M-1994.
3. This drawing conforms to the JEDEC Solid State Outline MO-137, Variation C
4. Recommended card reflow profile is per the JEDEC/IPC J-STD-020 specification for Small Body Components.

DOCUMENT CHANGE LIST

Revision 0.1 to Revision 0.9

- Updated max output frequency.
- Updated kV values in Table 3 on page 5.
- Updated "3.4. Spread Spectrum" on page 13.
- Added "5.1. Writing a Custom Configuration to RAM" on page 16.
- Added "5.7. HCSL Compatible Outputs" on page 20.
- Added "6.6. Trace Characteristics" on page 22.
- Updated "8. Register Descriptions" on page 25.
 - Added register descriptions.

Revision 0.9 to Revision 0.95

- Added 1.8 V VDDO support.
- Updated Table 2, "DC Characteristics," on page 4.
- Added soldering profile specs to Table 9, "Absolute Maximum Ratings¹," on page 8.

NOTES:

CONTACT INFORMATION

Silicon Laboratories Inc.

400 West Cesar Chavez
Austin, TX 78701
Tel: 1+(512) 416-8500
Fax: 1+(512) 416-9669
Toll Free: 1+(877) 444-3032

Please visit the Silicon Labs Technical Support web page:
<https://www.silabs.com/support/pages/contacttechnicalsupport.aspx>
and register to submit a technical support request.

The information in this document is believed to be accurate in all respects at the time of publication but is subject to change without notice. Silicon Laboratories assumes no responsibility for errors and omissions, and disclaims responsibility for any consequences resulting from the use of information included herein. Additionally, Silicon Laboratories assumes no responsibility for the functioning of undescribed features or parameters. Silicon Laboratories reserves the right to make changes without further notice. Silicon Laboratories makes no warranty, representation or guarantee regarding the suitability of its products for any particular purpose, nor does Silicon Laboratories assume any liability arising out of the application or use of any product or circuit, and specifically disclaims any and all liability, including without limitation consequential or incidental damages. Silicon Laboratories products are not designed, intended, or authorized for use in applications intended to support or sustain life, or for any other application in which the failure of the Silicon Laboratories product could create a situation where personal injury or death may occur. Should Buyer purchase or use Silicon Laboratories products for any such unintended or unauthorized application, Buyer shall indemnify and hold Silicon Laboratories harmless against all claims and damages.

Silicon Laboratories and Silicon Labs are trademarks of Silicon Laboratories Inc.
Other products or brandnames mentioned herein are trademarks or registered trademarks of their respective holders.