

EVALUATION KIT
AVAILABLE



RF Power Detector with Shutdown Control

MAX2209A

General Description

The MAX2209A is a wideband (800MHz to 2GHz) RF power detector. It takes an RF signal from the directional coupler at the input, and outputs a DC voltage proportional to the RF peak voltage. The change in output voltage versus temperature is very repeatable from part to part and enables a lookup table based on nominal behavior, minimizing the effective detection error to less than $\pm 0.5\text{dB}$ relative to room temperature.

The MAX2209A comes in a space-saving 2 x 2, 0.5mm pitch UCSP™.

Features

- ◆ -25dBm to -5dBm Power Detection Range
- ◆ $\pm 0.5\text{dB}$ Detection Error Due to Temperature
- ◆ +2.7V to +5V Single-Supply Operation
- ◆ Space-Saving 4-Bump, 1mm² UCSP Package
- ◆ Shutdown Control
- ◆ 140ns Step-Response Time

Applications

Dual-Band WCDMA Handsets
High-Speed Downlink Packet Access (HSDPA)
High-Speed Uplink Packet Access (HSUPA)

Ordering Information

PART	TEMP RANGE	PIN-PACKAGE	TOP MARK
MAX2209AEBS+	-40°C to +85°C	4 UCSP	AGJ

+Denotes a lead(Pb)-free/RoHS-compliant package.

Functional Diagram/Typical Operating Circuit

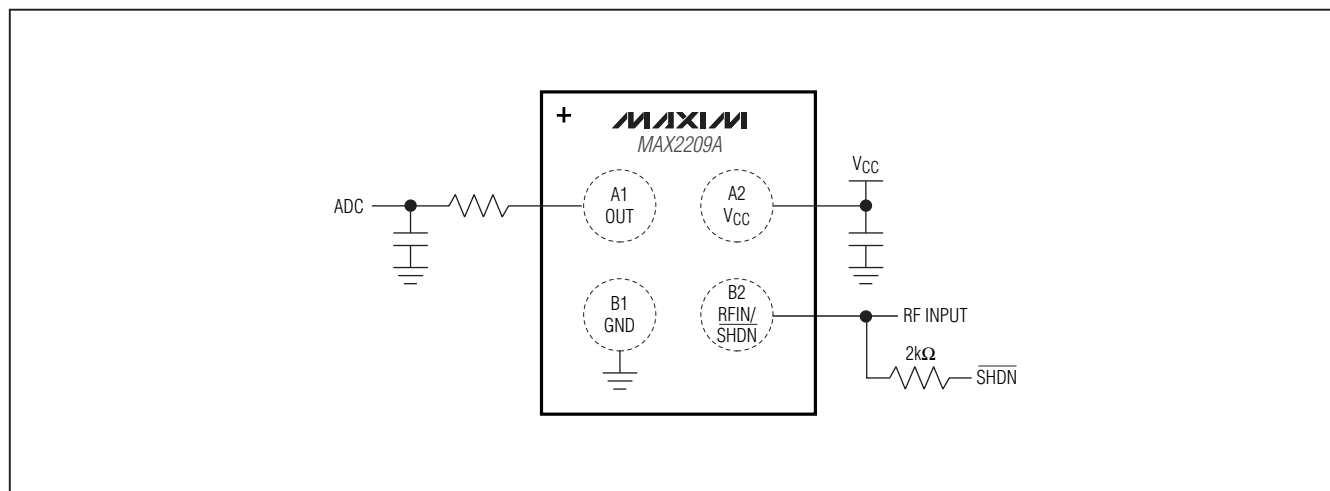

UCSP is a trademark of Maxim Integrated Products, Inc.



Maxim Integrated Products 1

For pricing, delivery, and ordering information, please contact Maxim Direct at 1-888-629-4642, or visit Maxim's website at www.maxim-ic.com.

RF Power Detector with Shutdown Control

ABSOLUTE MAXIMUM RATINGS

V _{CC} to GND.....	-0.3V to +6V	Junction-to-Ambient Thermal Resistance (θ_{JA}) (Note 1).....	335°C/W
RFIN to GND	-0.3V to + (V _{CC} + 0.3V)	Operating Temperature Range	-40°C to +85°C
OUT to GND	-0.3V to + (V _{CC} + 0.3V)	Storage Temperature Range.....	-65°C to +160°C
RFIN Input Power	+10dBm	Junction Temperature	+150°C
Continuous Power Dissipation (T _A = +70°C)		Bump Temperature (soldering, Note 2)	
4-Bump WLP (derate 3mW/°C above +70°C).....	238mW	Infrared (15s).....	+260°C
		Soldering Temperature (reflow)	+240°C

Note 1: Package thermal resistances were obtained using the method described in JEDEC specification JESD51-7, using a 4-layer board. For detailed information on package thermal considerations, refer to www.maxim-ic.com/thermal-tutorial.

Note 2: For detailed information on soldering, refer to Application Note 1891: *Wafer-Level Packaging (WLP) and Its Applications*.

Stresses beyond those listed under "Absolute Maximum Ratings" may cause permanent damage to the device. These are stress ratings only, and functional operation of the device at these or any other conditions beyond those indicated in the operational sections of the specifications is not implied. Exposure to absolute maximum rating conditions for extended periods may affect device reliability.



CAUTION! ESD SENSITIVE DEVICE

DC ELECTRICAL CHARACTERISTICS

(V_{CC} = 2.7V to 5.0V, no RF signal applied, T_A = -40°C to +85°C. Typical values are at V_{CC} = 2.8V, T_A = +25°C, unless otherwise noted.) (Note 3)

PARAMETER	CONDITIONS	MIN	TYP	MAX	UNITS
Supply Voltage		2.7		5.0	V
Supply Current			3.9	6	mA
Idle Output Voltage			35		mV
Output Current Source Capability	P _{IN} = -5dBm, V _{OUT} forced 100mV lower than open-circuit output voltage	1000	2300		μA
Output Current Sink Capability	P _{IN} = -25dBm, V _{OUT} forced 10mV higher than open-circuit output voltage	75	150		μA
Shutdown Current	V _{SHDN} = 0V		25	50	μA
SHDN Logic-High	V _{IH} , including 2kΩ resistor	1.2			V
SHDN Logic-Low	V _{IL} , including 2kΩ resistor			0.45	V
Turn-On Time	SHDN transitions to V _{IH} , V _{OUT} is within 90% of final value (Note 4)		1.5	2	μs
RF Step-Response Time	RF transitions from < -25dBm to -5dBm, V _{OUT} is within 90% of final value, 1kΩ + 10pF load (Note 4)		140	200	ns

RF Power Detector with Shutdown Control

AC ELECTRICAL CHARACTERISTICS

(50Ω system, VCC = 2.8V, TA = -40°C to +85°C. Typical values are at TA = +25°C, unless otherwise noted.) (Note 3)

PARAMETER	CONDITIONS	MIN	TYP	MAX	UNITS
RF Input Frequency		800		2000	MHz
RF Input Return Loss	800MHz		16		dB
	2000MHz		9		
Output Voltage, 836MHz	-5dBm input		0.88		V
	-25dBm input		0.06		
Output Voltage, 1950MHz	-5dBm input		0.72		V
	-25dBm input		0.06		
Residual Error after Room Temperature Calibration (TA = -40°C to +85°C) (Note 4)	-5dBm input			±0.5	dB
	-25dBm input			±1.5	

Note 3: Guaranteed by production test at TA = +25°C. Guaranteed by design and characterization at TA = -40°C and TA = +85°C.

Note 4: Guaranteed by design and characterization. See the *Typical Operating Characteristics*.

Typical Operating Characteristics

(VCC = 2.8V. Typical values are at TA = +25°C, unless otherwise noted.)

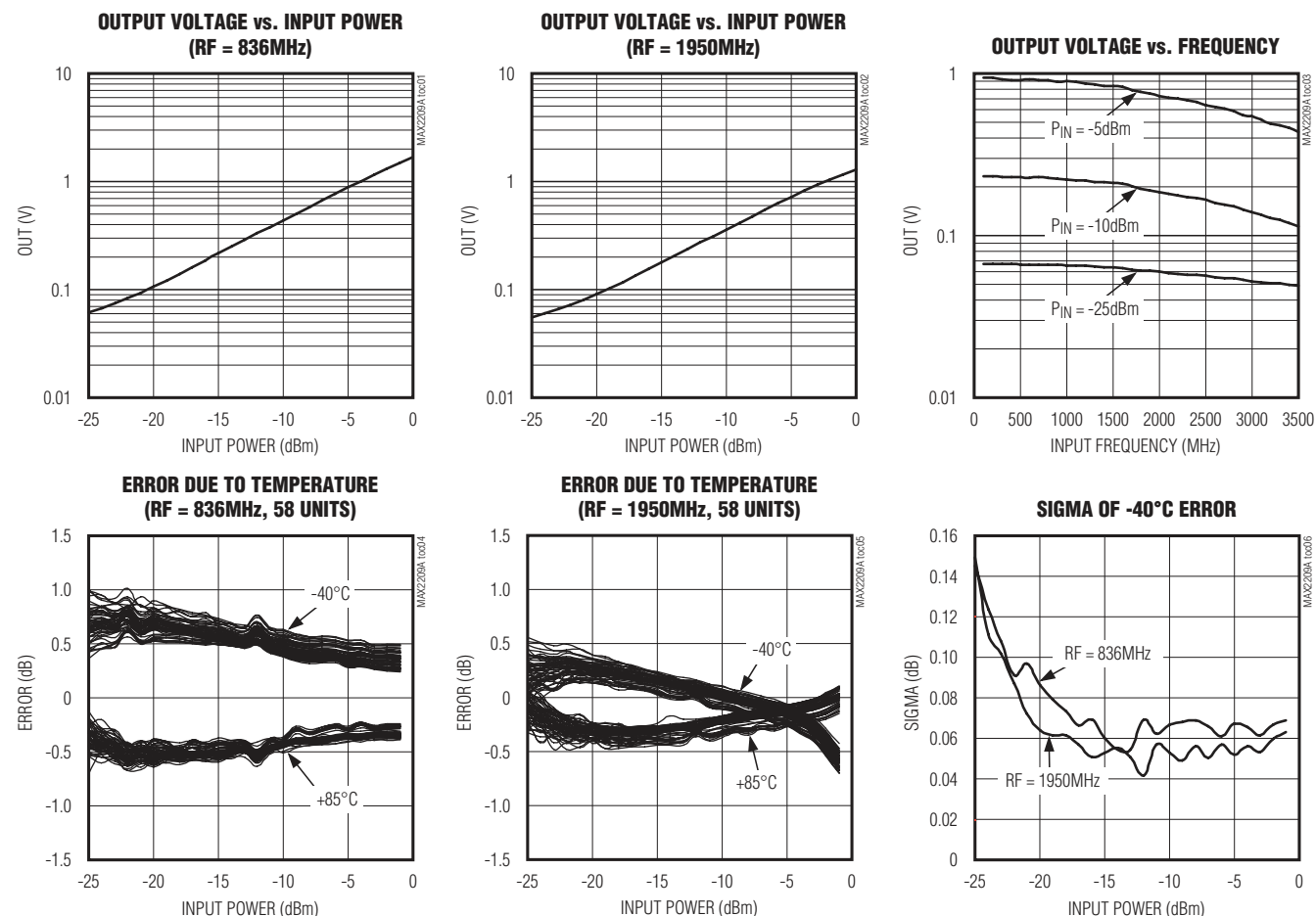

RF Power Detector with Shutdown Control

Typical Operating Characteristics (continued)

(VCC = 2.8V. Typical values are at TA = +25°C, unless otherwise noted.)

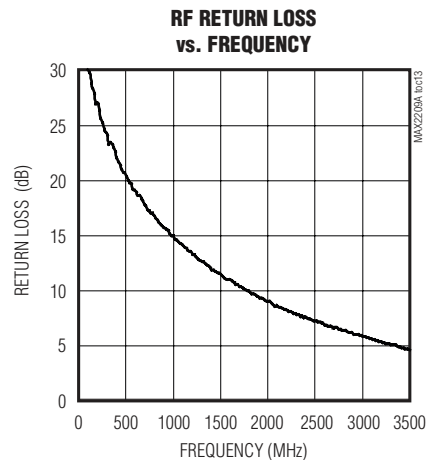
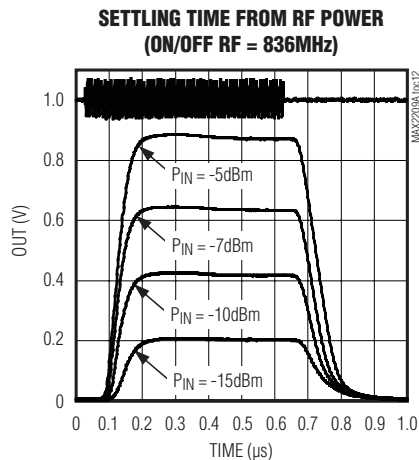
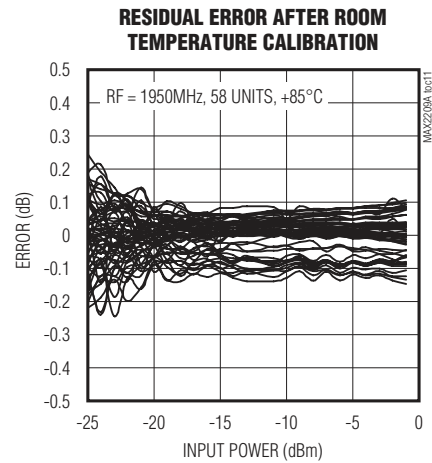
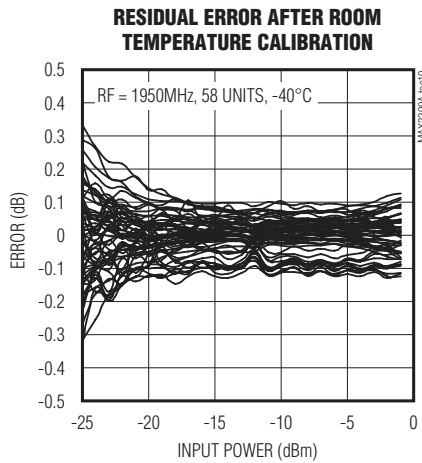
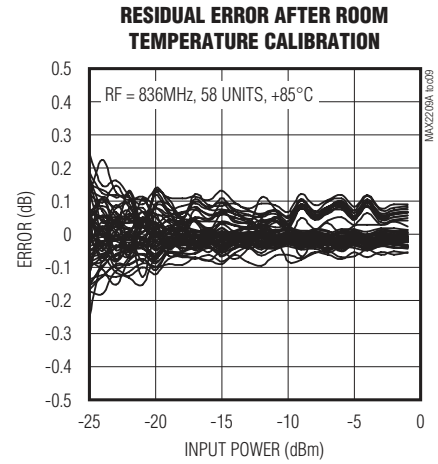
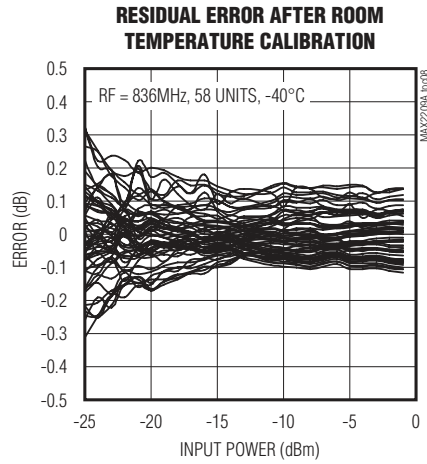
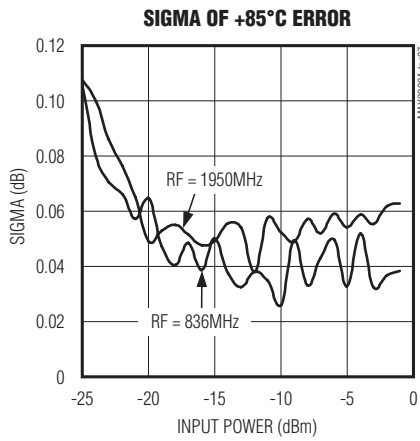

RF Power Detector with Shutdown Control

Bump Configuration

MAX2209A

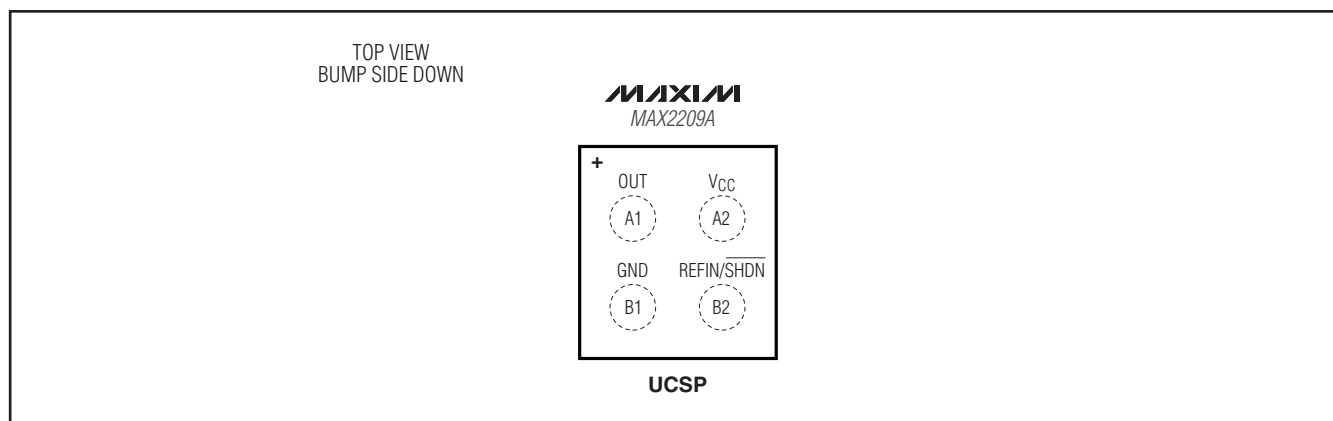

Bump Description

BUMP	NAME	FUNCTION
A1	OUT	Detector Output
A2	VCC	Power Supply. Bypass to GND with a capacitor as close as possible to the bump.
B1	GND	Ground Connection. Connect to PCB ground plane with as low inductance as possible.
B2	RFIN/SHDN	RF Input and Shutdown Control. AC-couple the RF input and DC couple the shutdown control through a 2kΩ resistor to this pin.

RF Power Detector with Shutdown Control

Detailed Description

The MAX2209A power detector is designed to operate from 800MHz to 2.0GHz. The device is ideal for wideband code-division multiple access (WCDMA), cdma2000®, and high-speed downlink/uplink packet access. The MAX2209A accepts an RF signal at the input, and outputs a temperature-independent voltage related to the input signal power. The output voltage expressed in dBV is proportional to the input power expressed in dBm. The device has a detection range from -25dBm to 0dBm.

Applications Information

The typical application circuit, as taken from the MAX2209A EV Kit, is shown in Figure 1. The IC can be shut down by forcing the RFIN/SHDN DC voltage low through a 2kΩ resistor. The output of the detector goes to an ADC for further processing by the baseband system. Connect a series resistor and shunt capacitor to the MAX2209A output to reduce residual amplitude ripple. The series resistor should not be less than 1kΩ.

EV kit gerber files, schematic, BOM, and updates are available on the MAX2209A product page at Maxim's website (www.maxim-ic.com).

Layout

There are two areas that require attention: the GND pin and the supply bypassing. Connect the GND pin to the PCB ground with a GND via as close as possible, and bypass VCC to ground with a capacitor as close as possible to the part.

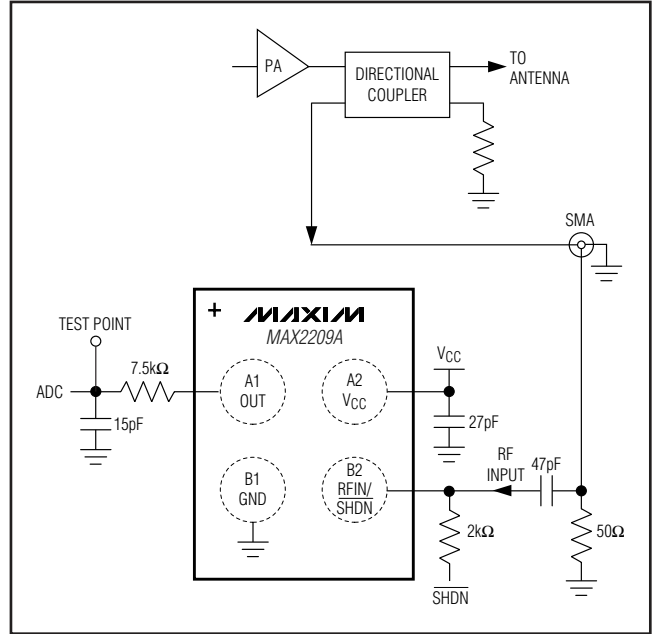

Figure 1. Typical Application Circuit from MAX2209A EV Kit

Chip Information

PROCESS: BIPOLAR

Package Information

For the latest package outline information and land patterns, go to www.maxim-ic.com/packages. Note that a "+", "#", or "-" in the package code indicates RoHS status only. Package drawings may show a different suffix character, but the drawing pertains to the package regardless of RoHS status.

PACKAGE TYPE	PACKAGE CODE	OUTLINE NO.	LAND PATTERN NO.
4 UCSP	B4+4	21-0007	—

cdma2000 is a registered trademark of the Telecommunications Industry Association.

RF Power Detector with Shutdown Control

Revision History

REVISION NUMBER	REVISION DATE	DESCRIPTION	PAGES CHANGED
0	9/10	Initial release	—

MAX2209A

Maxim cannot assume responsibility for use of any circuitry other than circuitry entirely embodied in a Maxim product. No circuit patent licenses are implied. Maxim reserves the right to change the circuitry and specifications without notice at any time.

Maxim Integrated Products, 120 San Gabriel Drive, Sunnyvale, CA 94086 408-737-7600 _____ 7