

DESCRIPTION: M12 FEMALE - PANEL MOUNT (REAR) - SOLDER CUP - 5 POS.

NOTE:

MATERIAL

HOUSING: PBT UL94V-0, BLACK
 CONTACT: BRASS
 NUT: BRASS
 SHELL: BRASS
 O-RING A: EPDM, BLACK
 O-RING B: EPDM, BLACK

FINISH

CONTACT: GOLD PLATED
 UNDER PLATE: OVER 50u" NICKEL
 NUT: NICKEL PLATED
 SHELL: NICKEL PLATED

ELECTRICAL

RATED CURRENT: 4A
 RATED VOLTAGE: 60V
 INSULATION RESISTANCE: 100 MOhms MIN.
 CONTACT RESISTANCE: 10 mOhms MAX.
 WATER PROOF: IP67

ENVIRONMENT

OPERATION TEMPERATURE: -40°C TO +85°C
 MAX WIRE AWG: 22

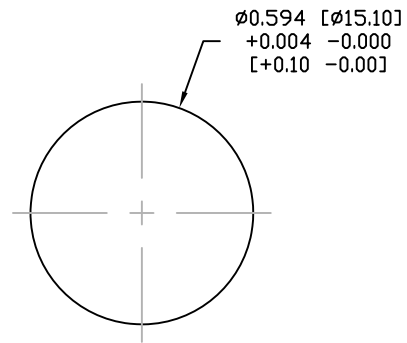

PANEL CUTOUT

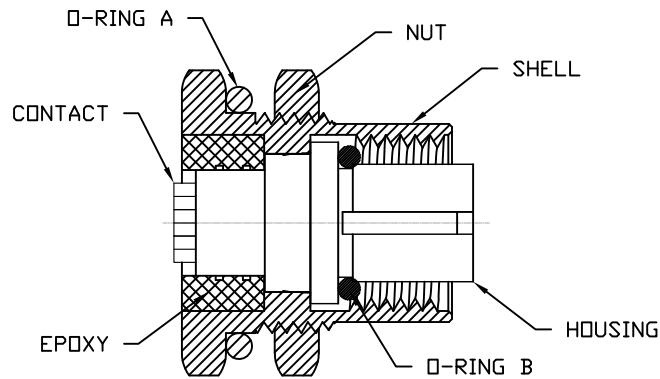

859-005-203R00Y

3 = BRASS/NICKEL SHELL & NUT
 S = STAINLESS STEEL SHELL & NUT

1 = GOLD FLASH
 4 = 10u" GOLD

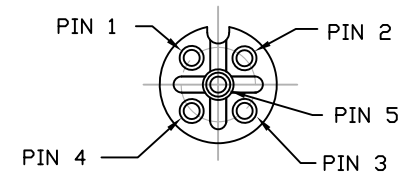
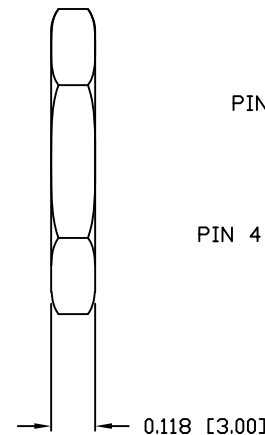
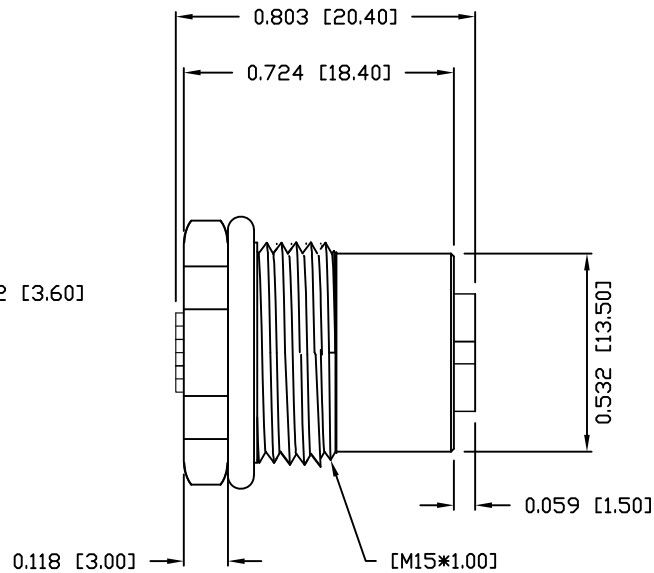
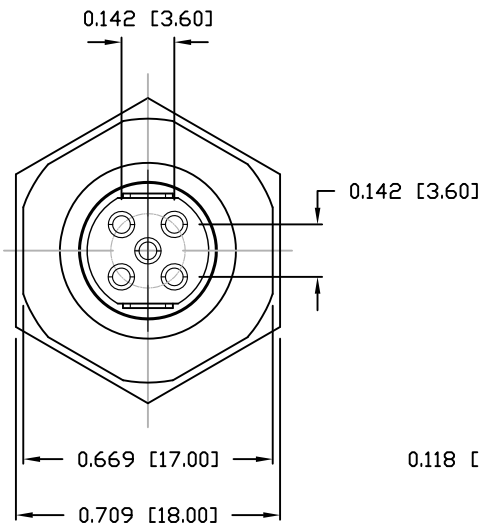

RoHS COMPLIANT

UNITS = INCHES [MM]

DO NOT SCALE FROM DRAWING



THESE DRAWINGS AND SPECIFICATIONS ARE THE PROPERTY OF NorComp AND SHALL NOT BE REPRODUCED, COPIED OR USED AS THE BASIS FOR THE MANUFACTURE OR SALE OF APPARATUS WITHOUT WRITTEN PERMISSION.

DRAWN:

M. SIGMON

DATE:

03-07-16

NorComp

SCALE:

NTS

SHEET

1

OF

1

REV

3

DWG NO.

859-005-203R00Y