

used for: D-SUB HD FILTER

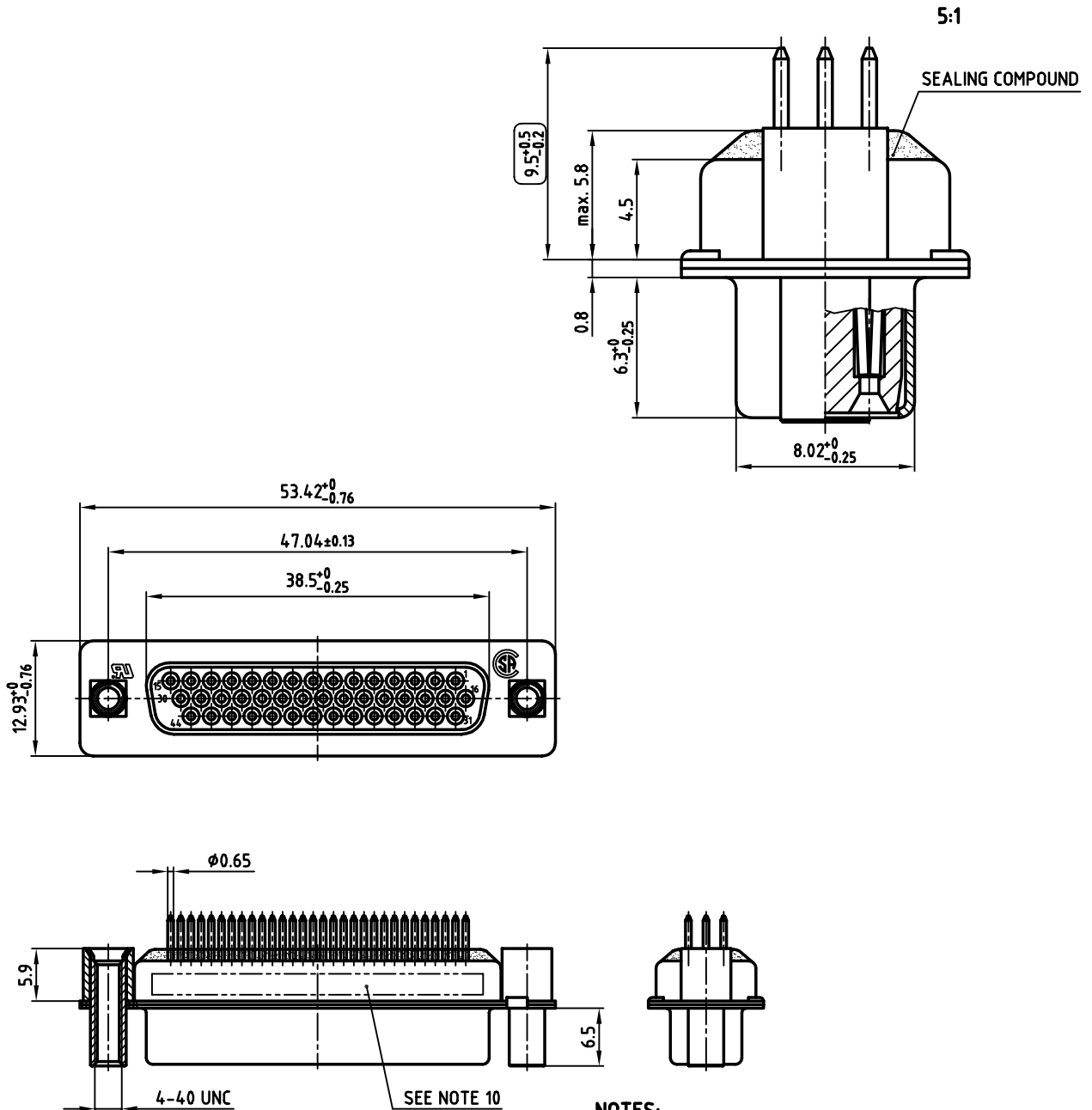

NOTES:

1. METAL SHELLS: STEEL; min. 320µ" TIN
2. INSULATORS: PBT GF UL 94 V-0, BLACK
3. CONTACTS: COPPER ALLOY
PLATING: 8µ" HARD GOLD OVER min. 50µ" NICKEL
4. THREADED REAR SPACER / FRONT THREADED LOCK: COPPER ALLOY; min. 200µ" TIN over 80µ" NICKEL
5. SLEEVE: COPPER ALLOY; min. 200µ" TIN over 80µ" NICKEL
6. P.C.B. HOLE DRILLINGS ON DRAWING NO.: 16V11H6B
7. CAPACITANCE: SEE TABLE
8. DIELECTRIC WITHSTANDING VOLTAGE: 300V DC
9. MAXIMUM TORQUE VALUE FOR THREAD: 6" LBS
10. CONNECTOR IS PART MARKED: PART-NO. CONEC Y/WW
11. = CHECK DIMENSION

CAPACITANCE	PART NO.
180pF ±20%	242A27600X
370pF ±20%	242A18400X
830pF ±20%	242A18440X

APPROVAL * FREIGABE * DEBLOCAGE * AUTORIZACION * APPROVAL

CUSTOMER APPROVAL DATE:

NAME: TITLE:

COMPANY NAME:

APPROVAL * FREIGABE * DEBLOCAGE * AUTORIZACION * APPROVAL

THIS DRAWING MAY NOT BE COPIED OR REPRODUCED IN ANY WAY, AND MAY NOT BE PASSED ON TO A THIRD PARTY, WITHOUT WRITTEN PERMISSION. OWNERSHIP AND COPYRIGHT OF CONEC GmbH DO NOT ALTER CAD DRAWING BY HAND

rev.	description	date	name

tolerance dim. in mm

scale: 2:1 (5:1)

material: SEE NOTES

title: **D-SUB HD FILTER FEMALE**
44pos. SOLDER PIN STRAIGHT
threaded rear spacer and front threaded lock

dwg no: AutoCAD 2000 DIN-A

24K1A444 3 sh:1/1

part no: SEE TABLE

