

LOC	DIST	REVISIONS					
AA	00	P	LTN	DESCRIPTION	DATE	DWN	APVD
		B5		ECR-11-009822	11MAY2011	JJ	MOW
		C		ECR-12-002445	09FEB2012	JJ	AC
		D		ECO-18-005828	27MAR2018	LL	SH

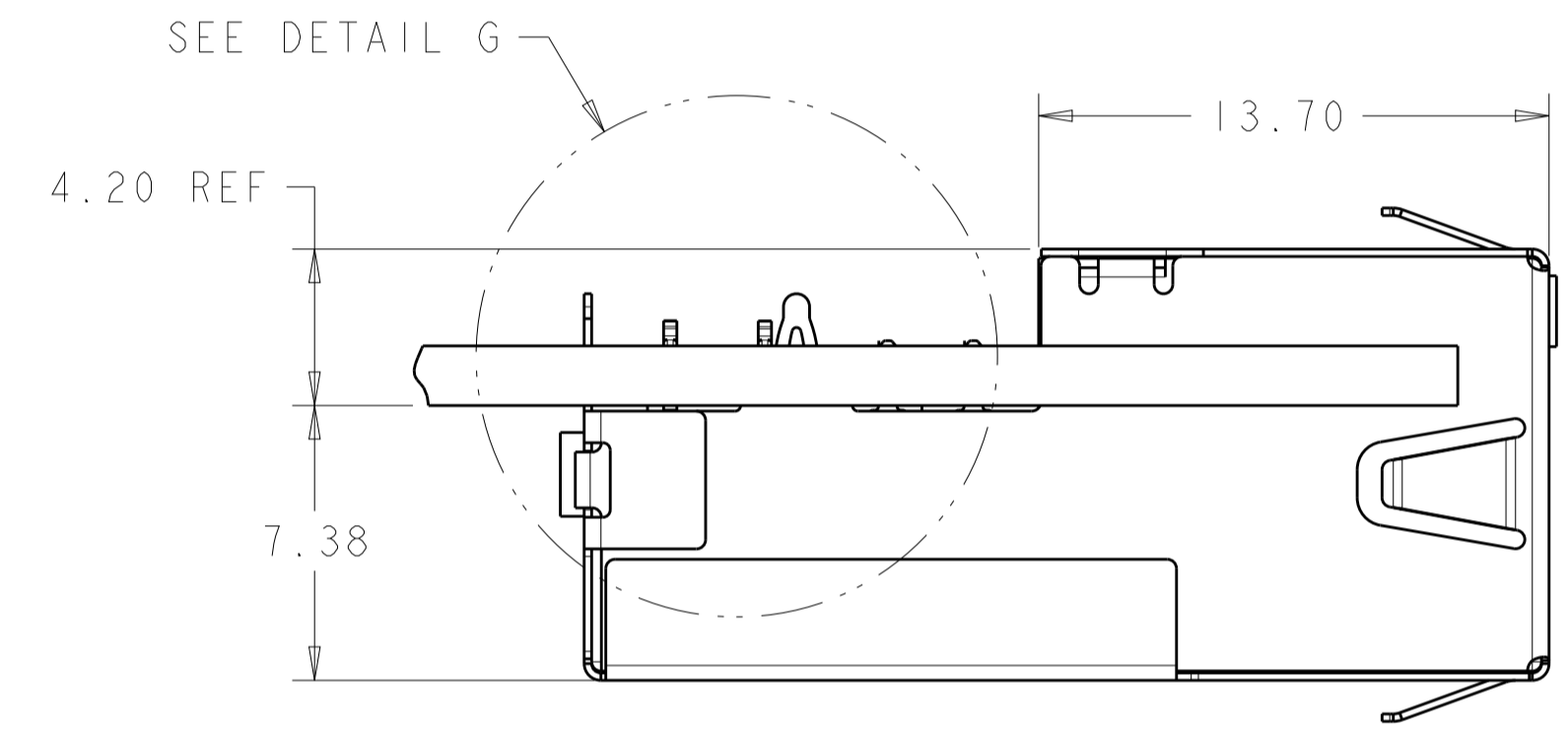

VIEW SHOWN ASSEMBLED TO PCB ONLY

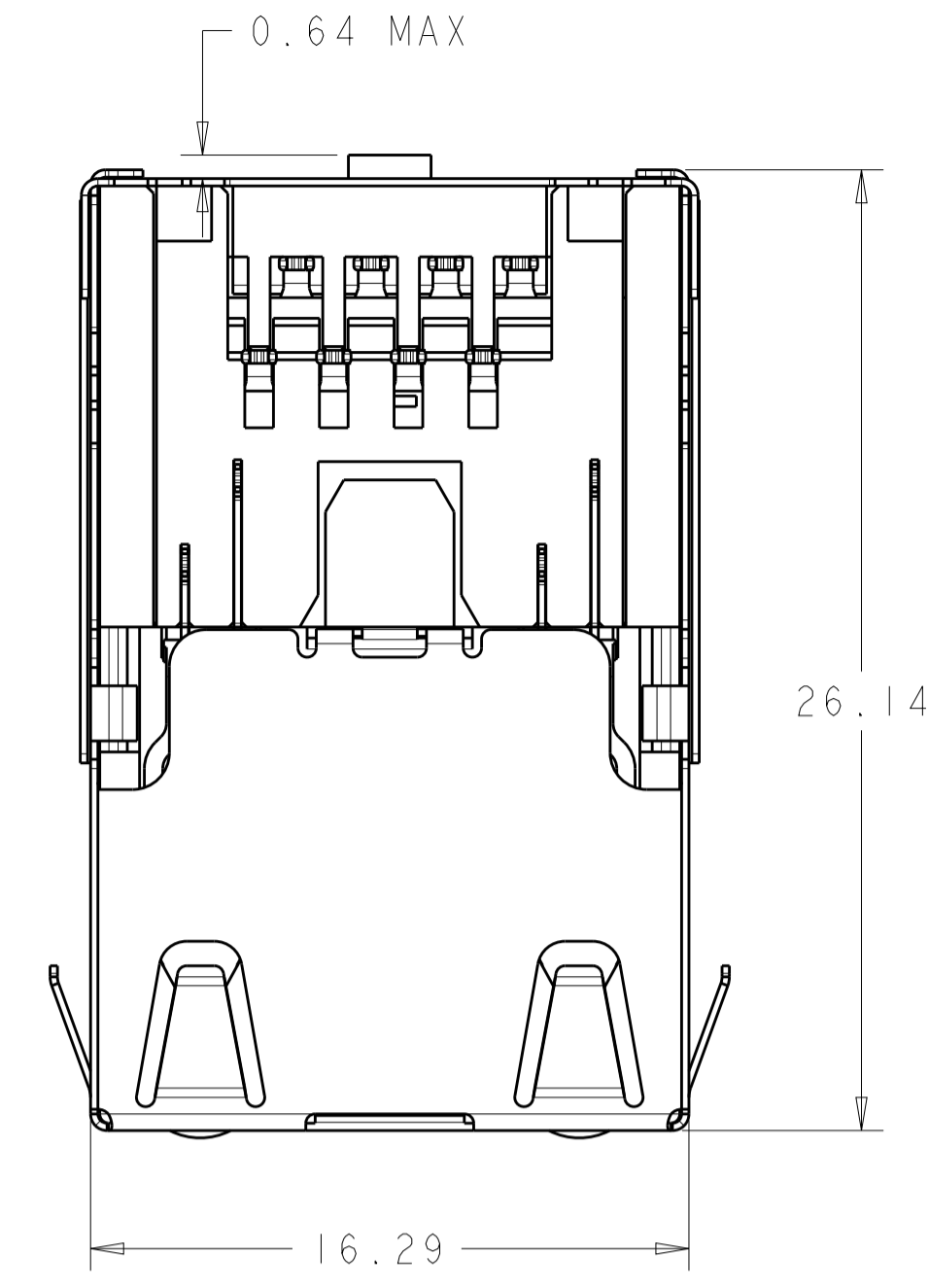
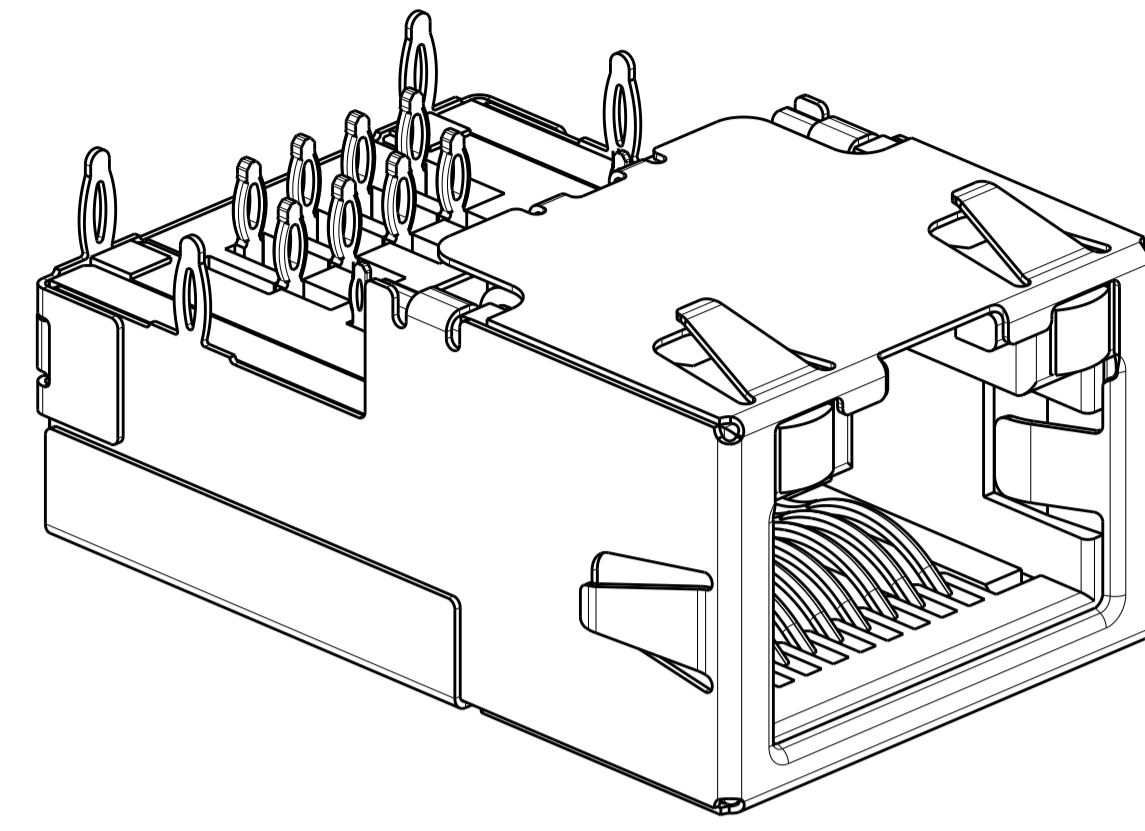
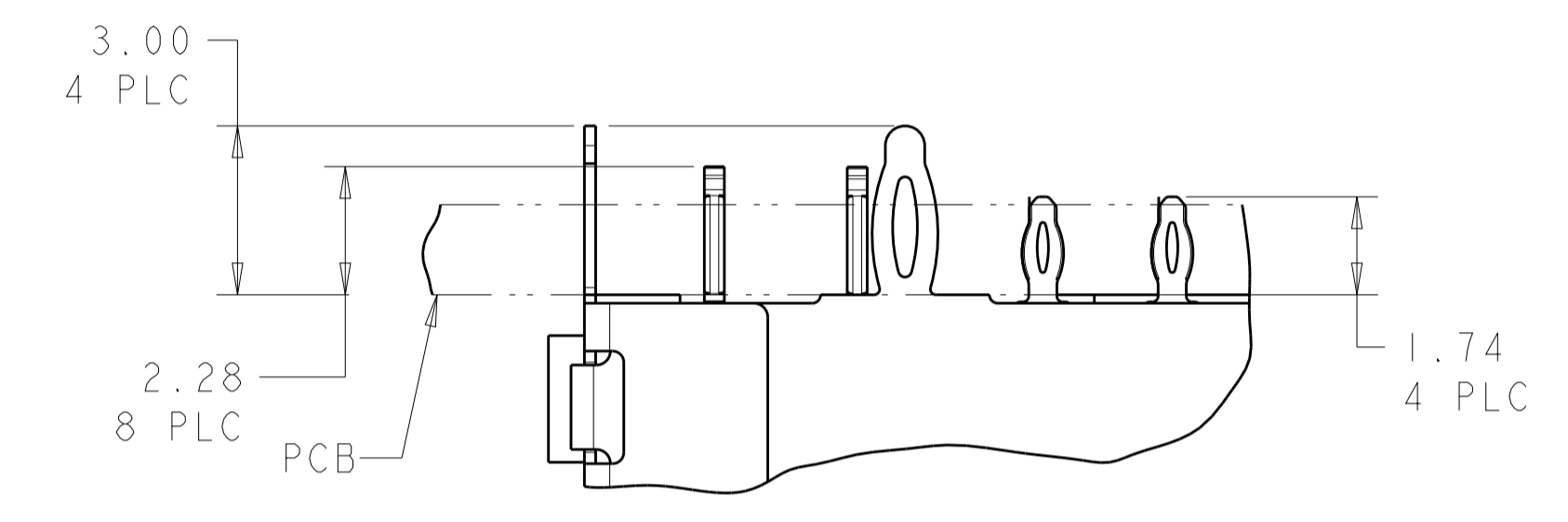
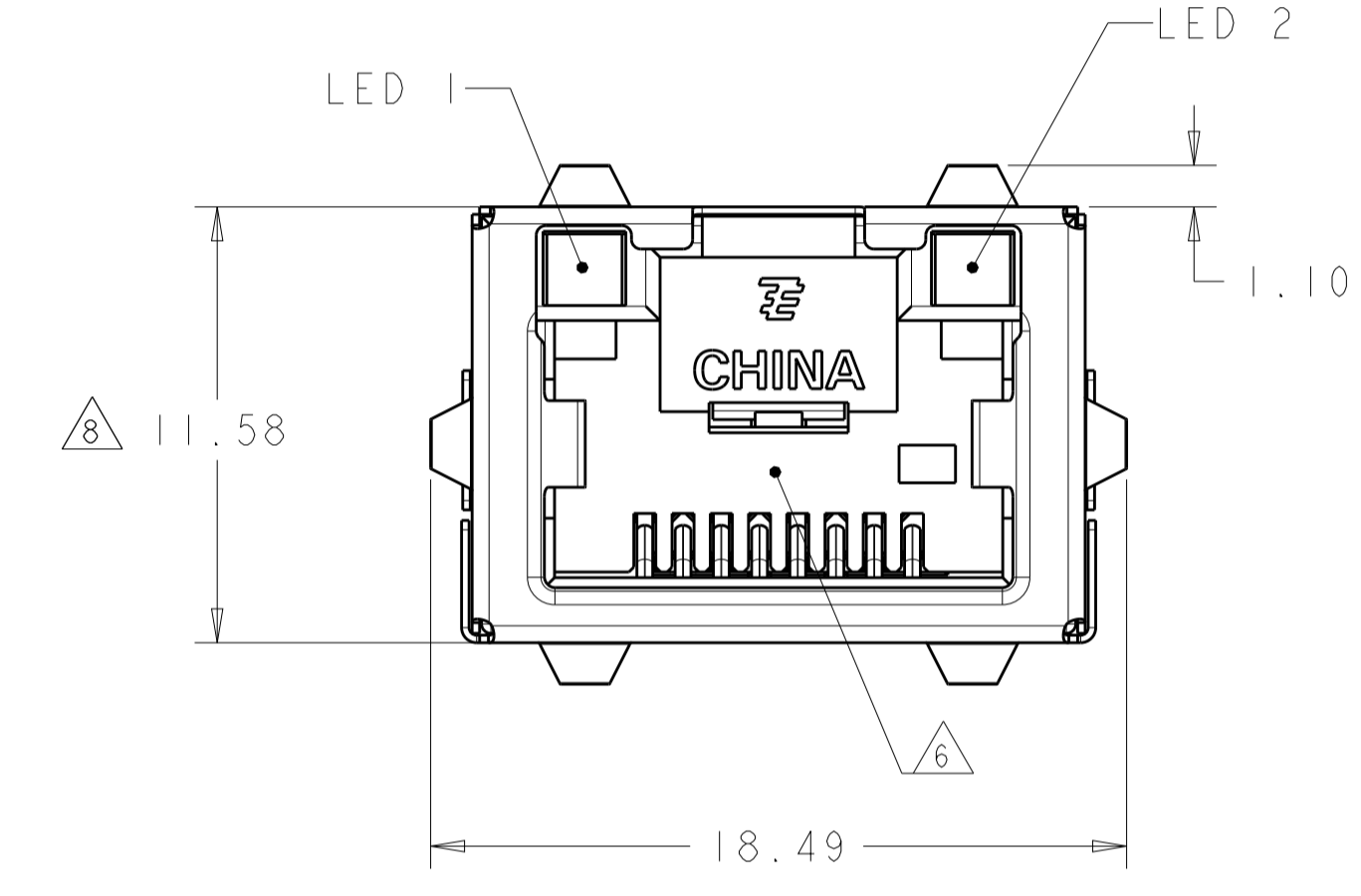

DETAIL G SCALE 8:1

- MATERIALS:  
 HOUSING: BLACK THERMOPLASTIC, 94V-0.  
 SHIELD: COPPER ALLOY WITH 0.76µm MIN NICKEL PLATE  
 CONTACTS: PHOSPHOR BRONZE WITH 1.27µm MIN GOLD AT MATING INTERFACE OVER 1.27µm MIN NICKEL UNDERPLATE.
  - PERFORMANCE:  
 INSERTION LOSS: 0.4dB @ 100 MHz.  
 RETURN LOSS: 12.0dB @ 100 MHz.  
 CROSSTALK ATTENUATION: -43dB MINIMUM @ 100 MHz  
 CURRENT: 0.6 AMPERE MAXIMUM PER SINGAL CONTACT.
  - LED'S COMPLIANT WITH IEC60825-1 SAFETY OF LASER PRODUCTS WHEN OPERATED AT CURRENT OF 20mA.
  - ALL DIMENSIONS NOMINAL.
  - RECOMMENDED MOTHERBOARD PCB THICKNESS: 1.60±0.16.
- 6 RJ45 PORT CONFORMS TO FCC RULES AND REGULATIONS PART 68 SUB-PART F.
- 7 TE LOGO, PART NUMBER, DATE CODE AND COUNTRY OF ORIGIN TO BE MARKED IN APPROXIMATE LOCATION SHOWN.
- 8 THIS DIMENSION MEETS THE ADVANCED MEZZANINE CARD (AMC) SPECIFICATION.
- 9 PIN 9,10,11,12 ARE LED LEAD PINS, For 1888250-3, NO LED INTEGRATED, HOLES ON PCB FOR THESE PINS ARE ONLY OPTIONAL.
- 10 LED WAVELENGTH FOR THE PN 1888250-7:  
 GREEN: 520nm ~ 525nm; YELLOW: 590nm ± 5nm.

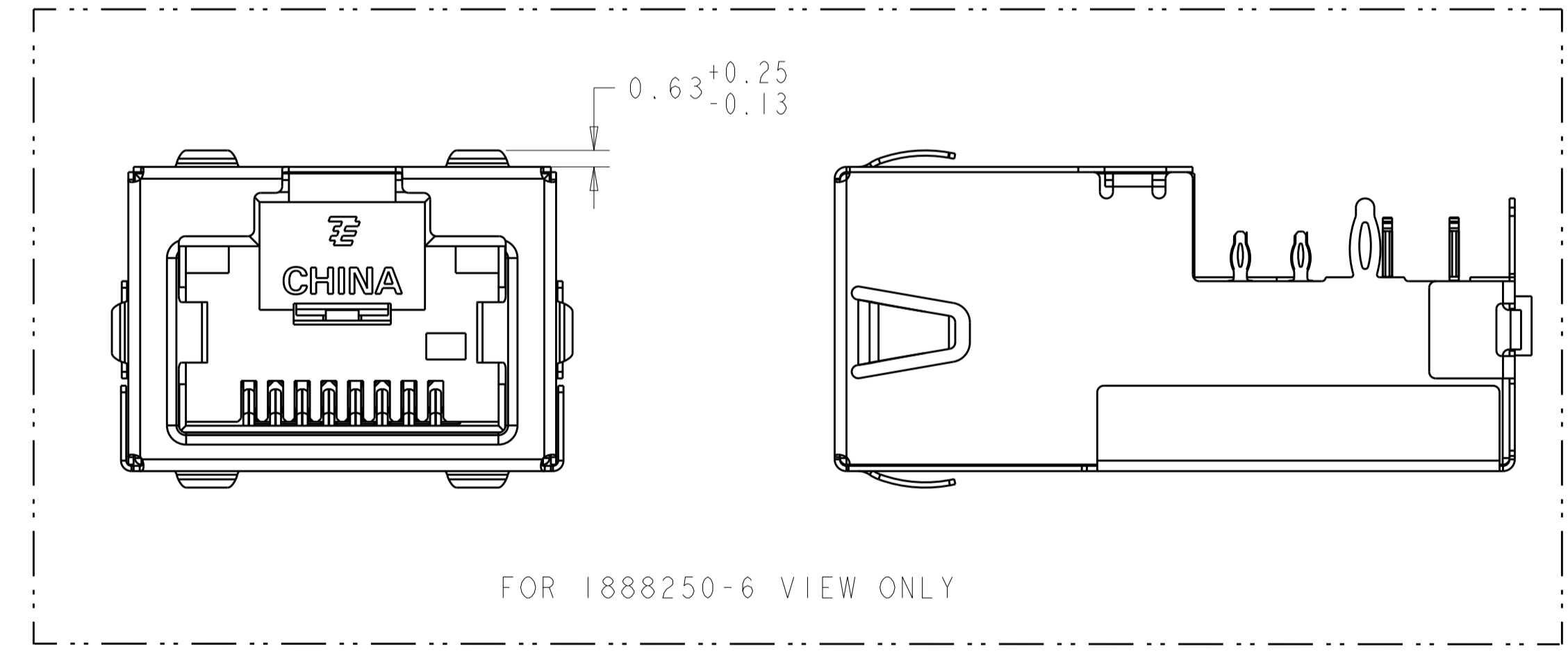

FOR 1888250-6 VIEW ONLY

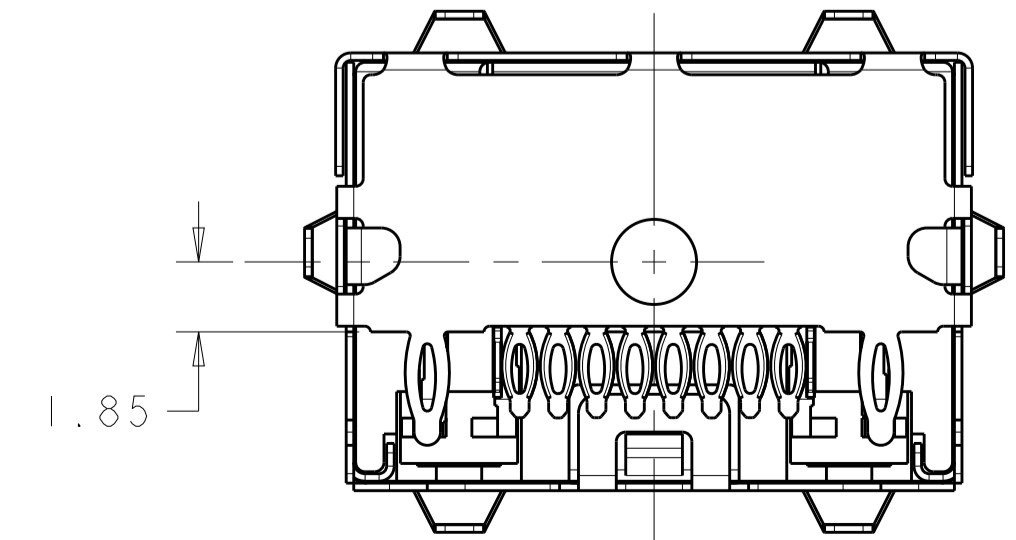

LED #1	LED #2	PART NUMBER
GRN/YEL	GRN/YEL	1888250-7
-	-	1888250-6
YELLOW	GREEN	1888250-5
GREEN	GREEN	1888250-4
-	-	1888250-3
GRN/YEL	GRN/YEL	1888250-2
GREEN	YELLOW	1888250-1

THIS DRAWING IS A CONTROLLED DOCUMENT. DWN: MS/L.A.MAYER 15FEB2008  
 CHG: J.WESTMAN 15FEB2008  
 APVD: S.FLICKINGER 15FEB2008

**TE** TE Connectivity

NAME: CONNECTOR ASSEMBLY, LOW PROFILE, PRESS FIT, MODULAR JACK, 1X1, RJ45

PRODUCT SPEC: 108-2274  
 APPLICATION SPEC: 114-13179

SIZE: CAGE CODE DRAWING NO: A100779C=1888250  
 RESTRICTED TO: 1 OF 3

SCALE: 5:1 SHEET 1 OF 3 REV D

LOC		DIST		REVISIONS			
P	LTN	DESCRIPTION	DATE	DMN	APVD		
-	-	SEE SHEET 1	-	-	-		

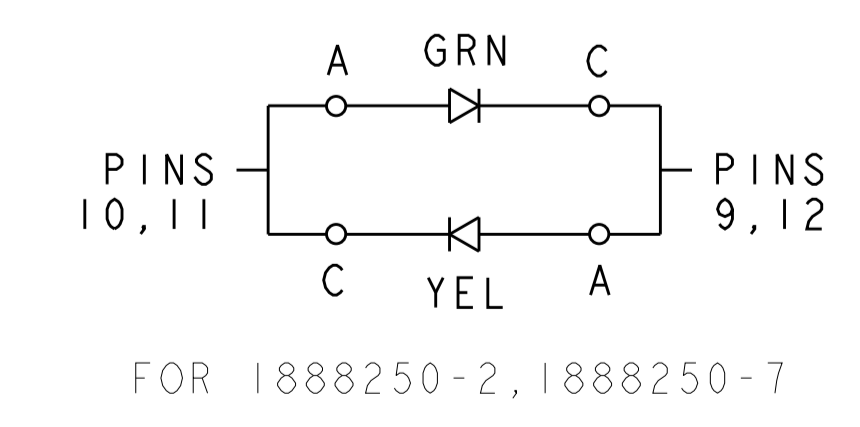
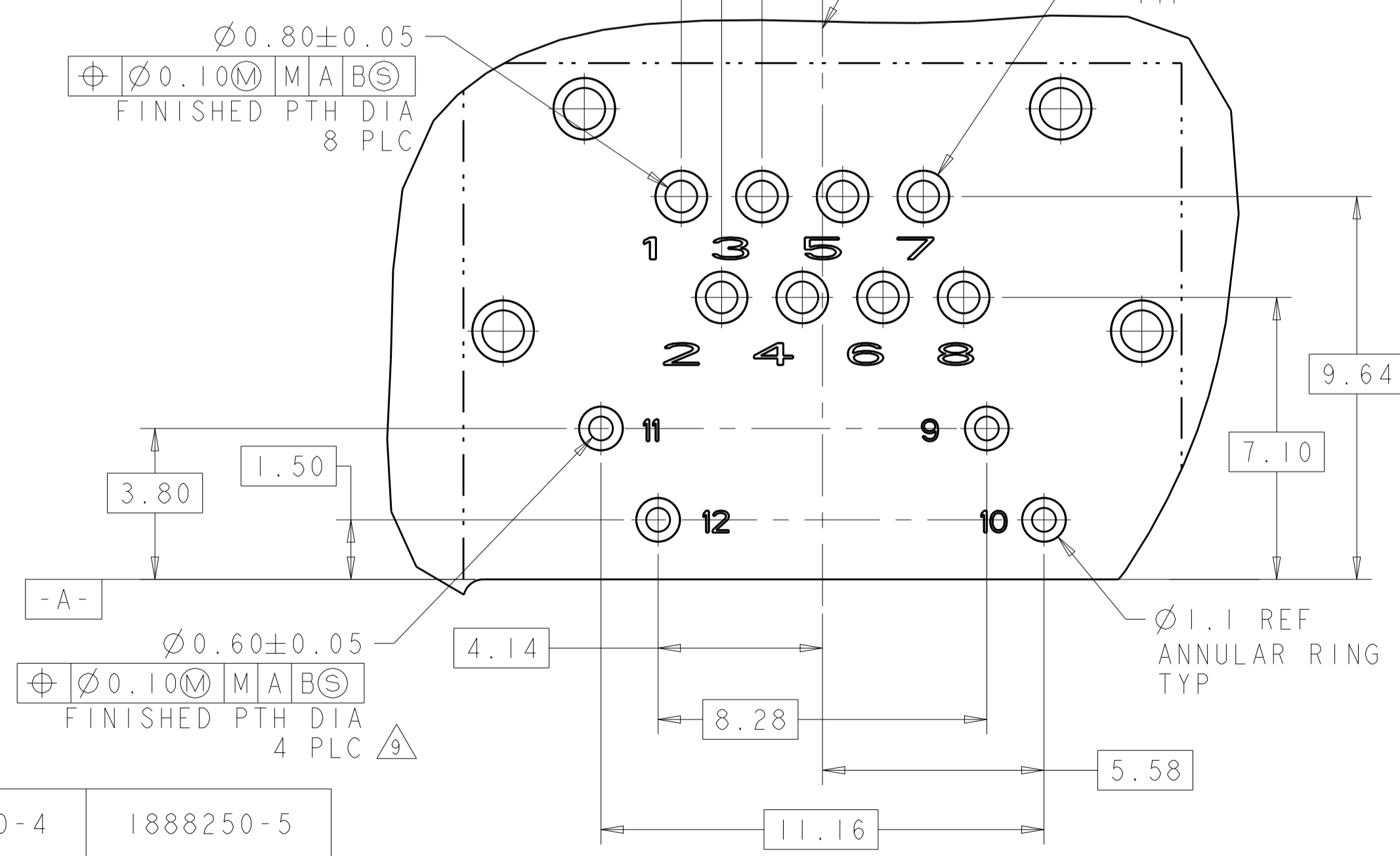
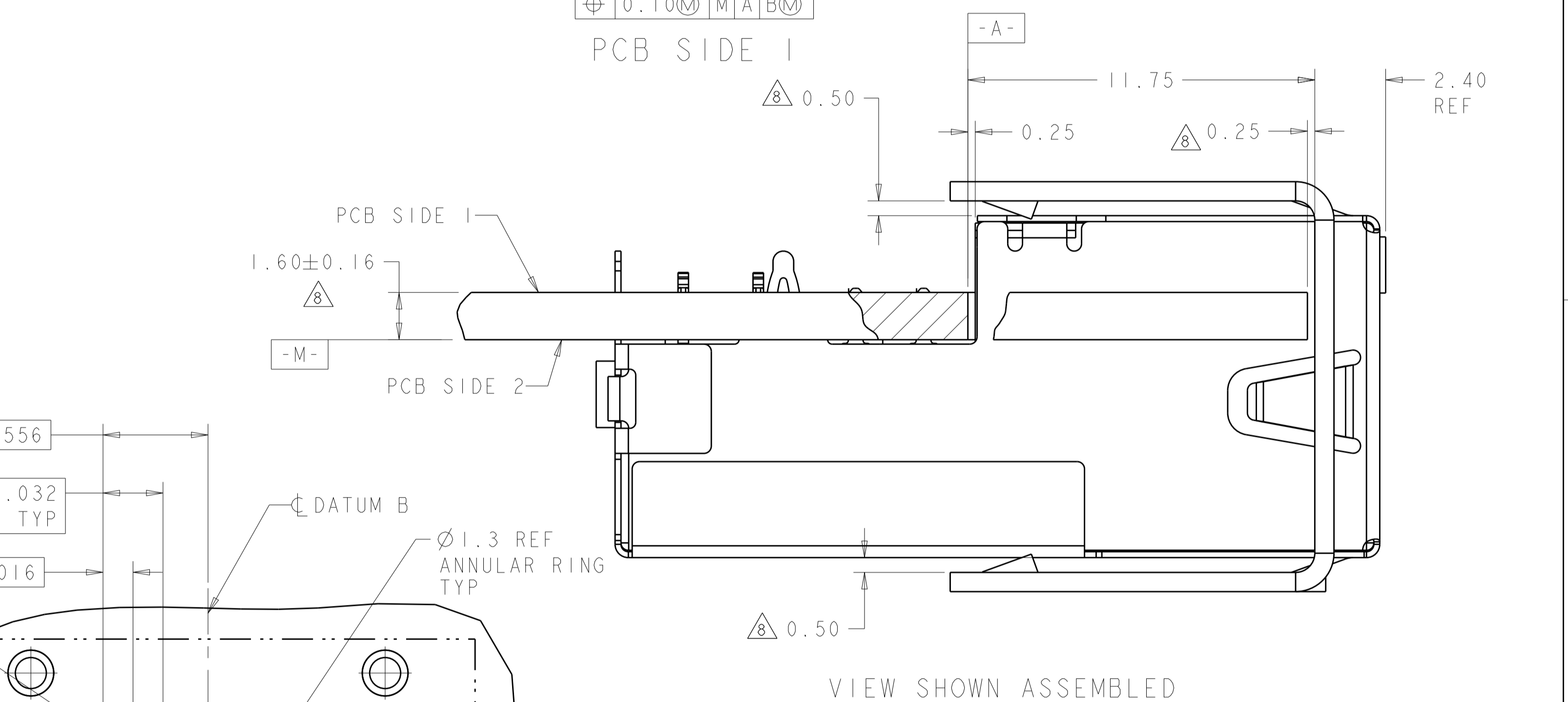
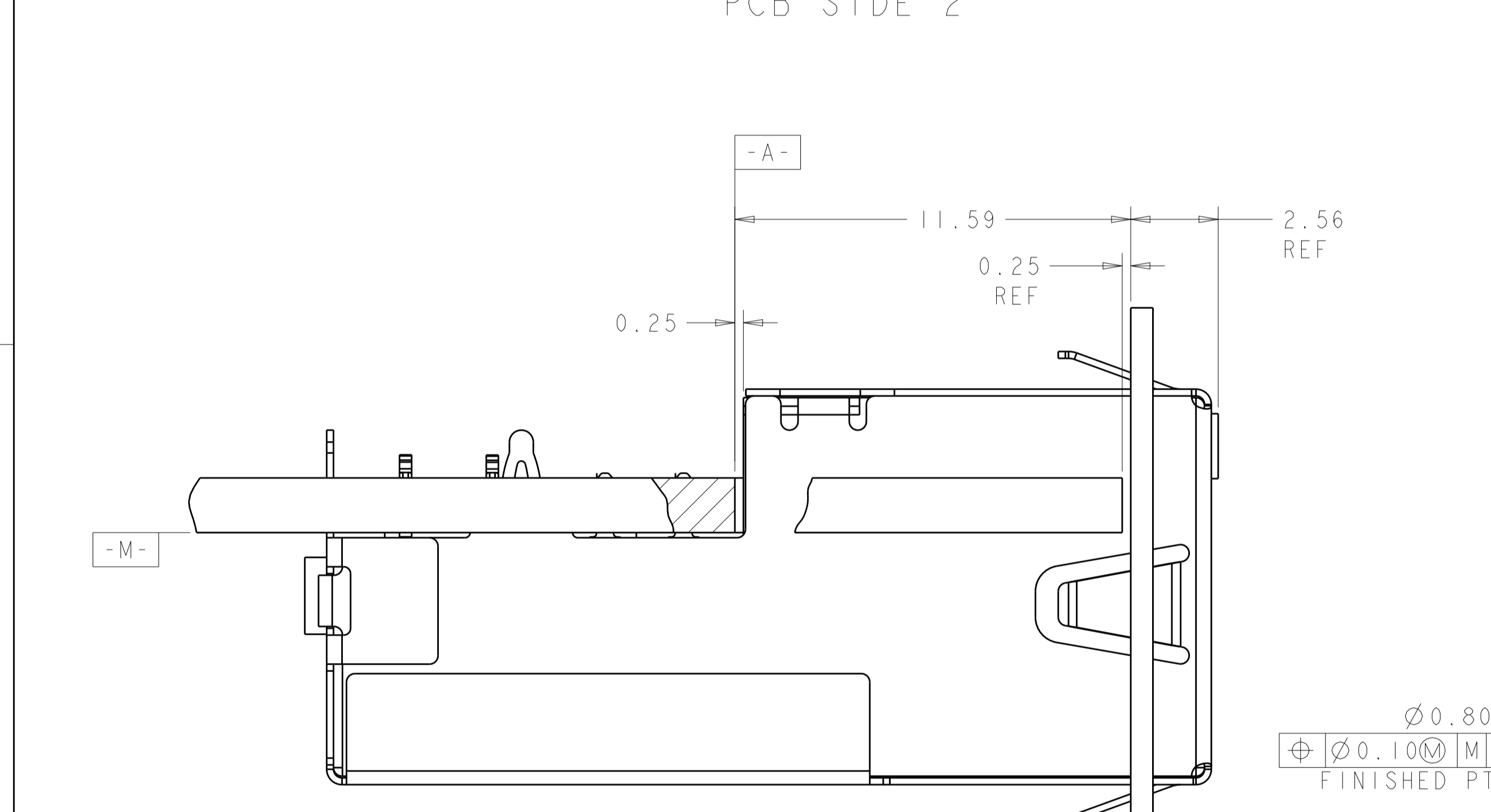
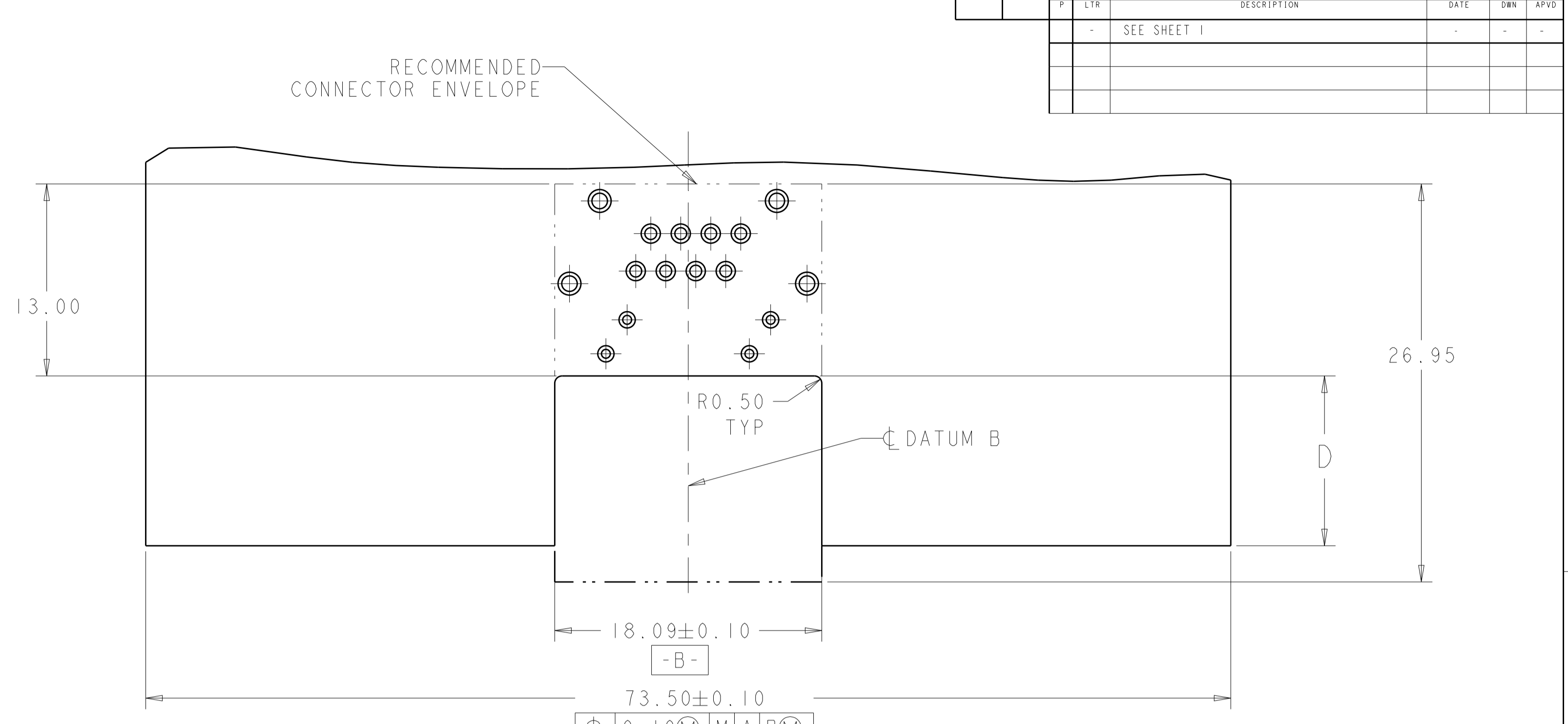
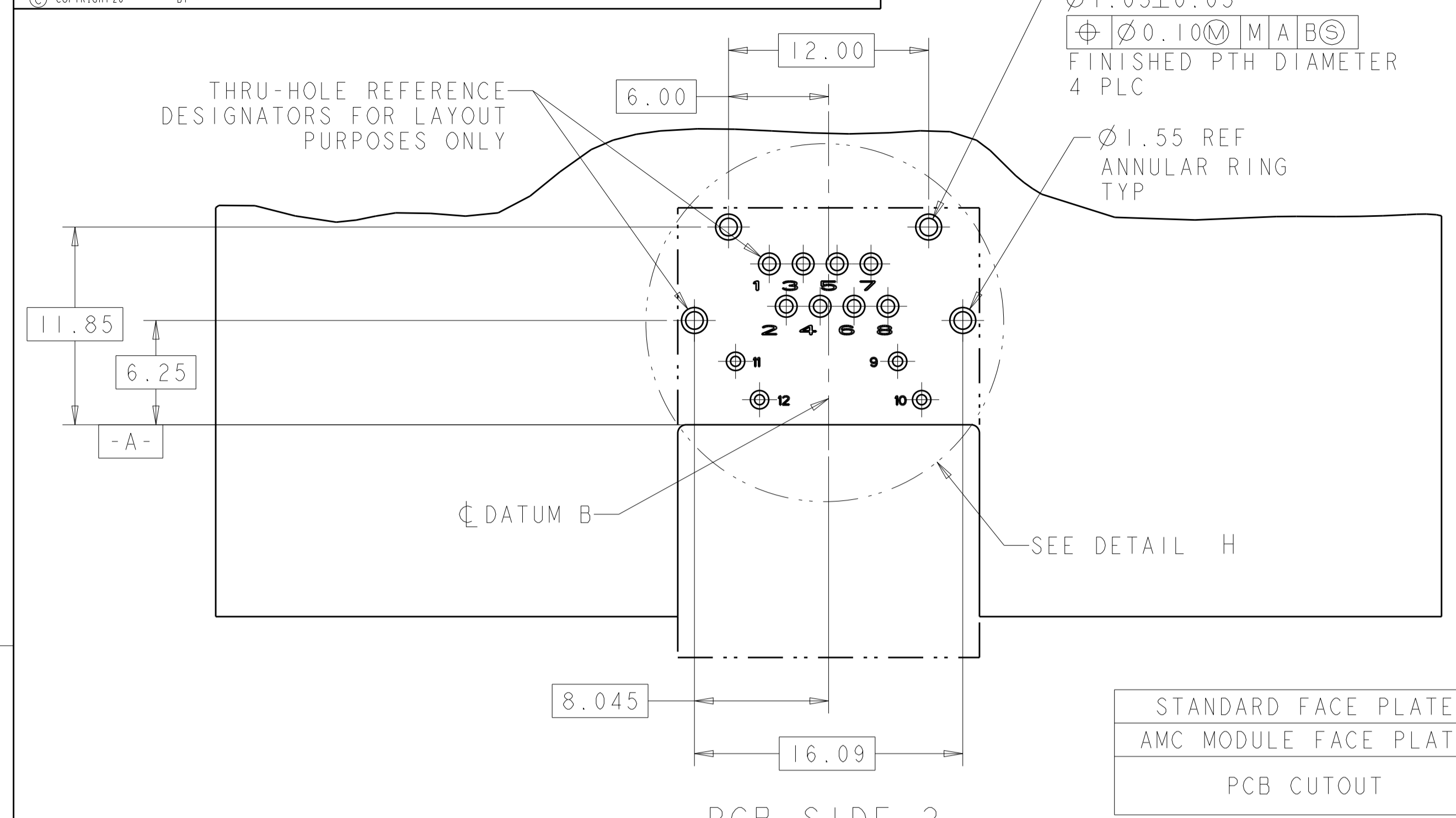

	PIN #	1888250-1	1888250-2 1888250-7	1888250-3 1888250-6	1888250-4	1888250-5
LED 1	9	CATHODE (-)	ANODE (YEL), CATHODE (GRN)	-	CATHODE (-)	CATHODE (-)
	10	ANODE (+)	ANODE (GRN), CATHODE (YEL)	-	ANODE (+)	ANODE (+)
LED 2	11	ANODE (+)	ANODE (GRN), CATHODE (YEL)	-	ANODE (+)	ANODE (+)
	12	CATHODE (-)	ANODE (YEL), CATHODE (GRN)	-	CATHODE (-)	CATHODE (-)

THIS DRAWING IS A CONTROLLED DOCUMENT.

DMN: MS/L.A.MAYER 15FEB2008  
 CHK: J.WESTMAN 15FEB2008  
 APVD: S.FLICKINGER 15FEB2008

NAME: CONNECTOR ASSEMBLY, LOW PROFILE, PRESS FIT, MODULAR JACK, IX1, RJ45

PRODUCT SPEC: 108-2274  
 APPLICATION SPEC: 114-13179

SIZE: A1  
 CAGE CODE: 100779  
 DRAWING NO: 1888250

RESTRICTED TO: -

MATERIAL: SEE NOTE 1  
 FINISH: SEE NOTE 1

WEIGHT: -  
 CUSTOMER DRAWING

SCALE: 5:1  
 SHEET: 2 OF 3  
 REV: D

LOC		DIST		REVISIONS			
P	LTN	DESCRIPTION	DATE	DMN	APVD		
-	-	SEE SHEET 1	-	-	-		

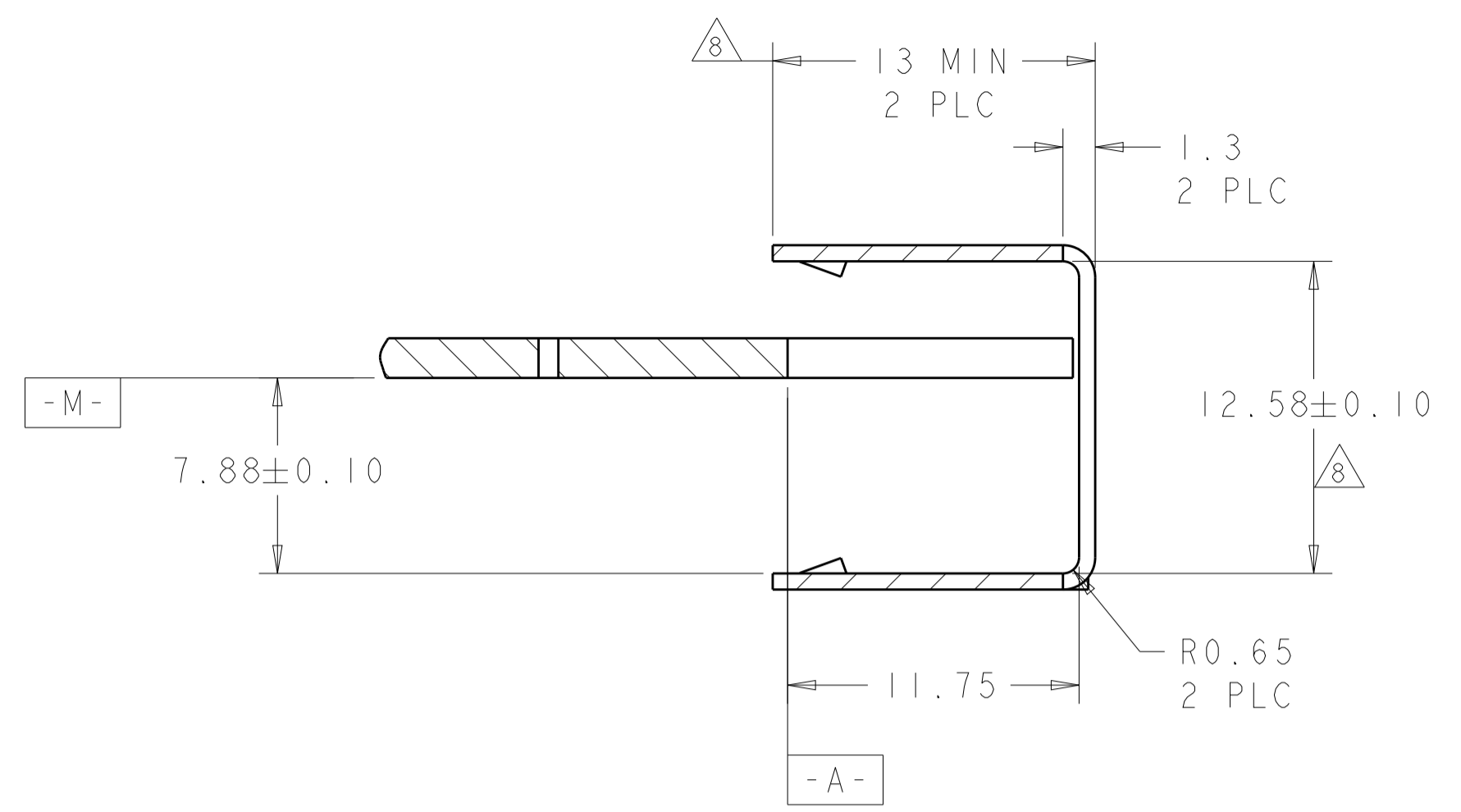

SECTION Z-Z

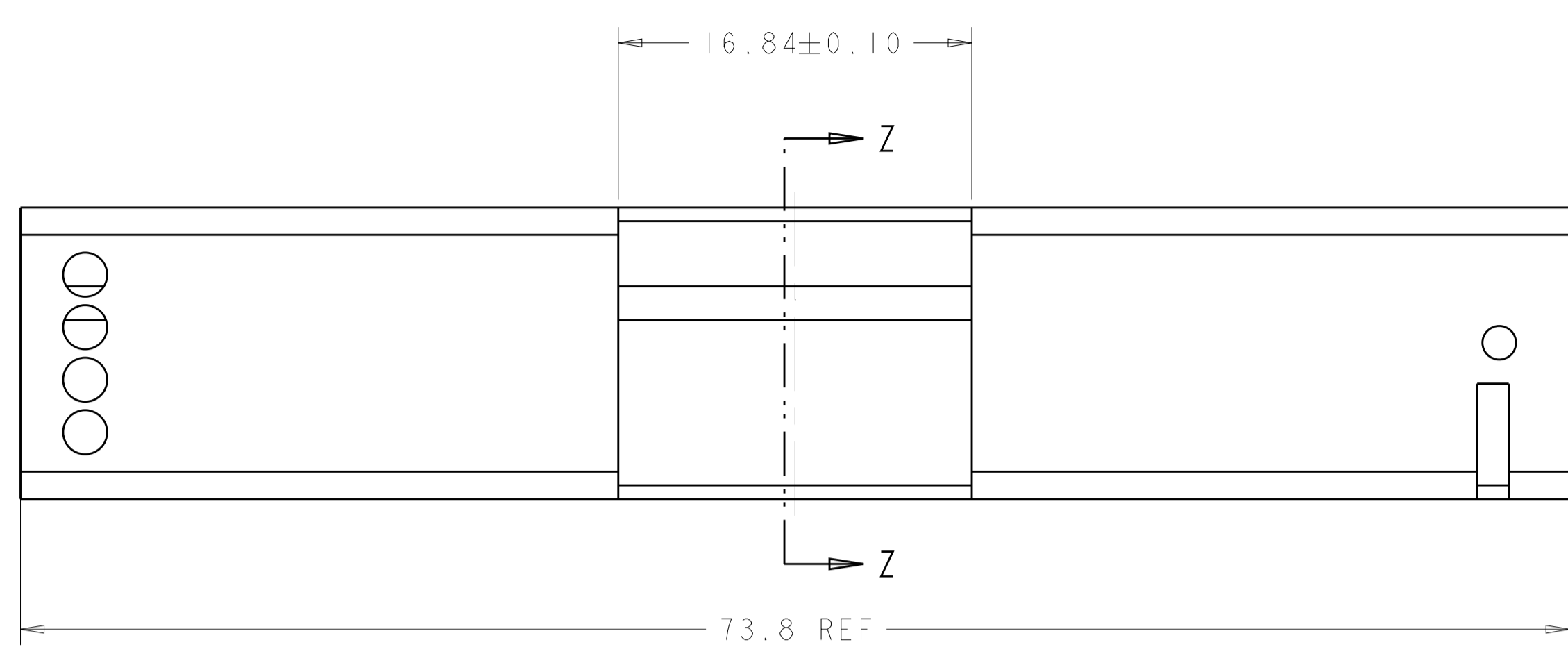

AMC SINGLE WIDTH, HALF HEIGHT MODULE FACE PLATE  
SCALE 4:1

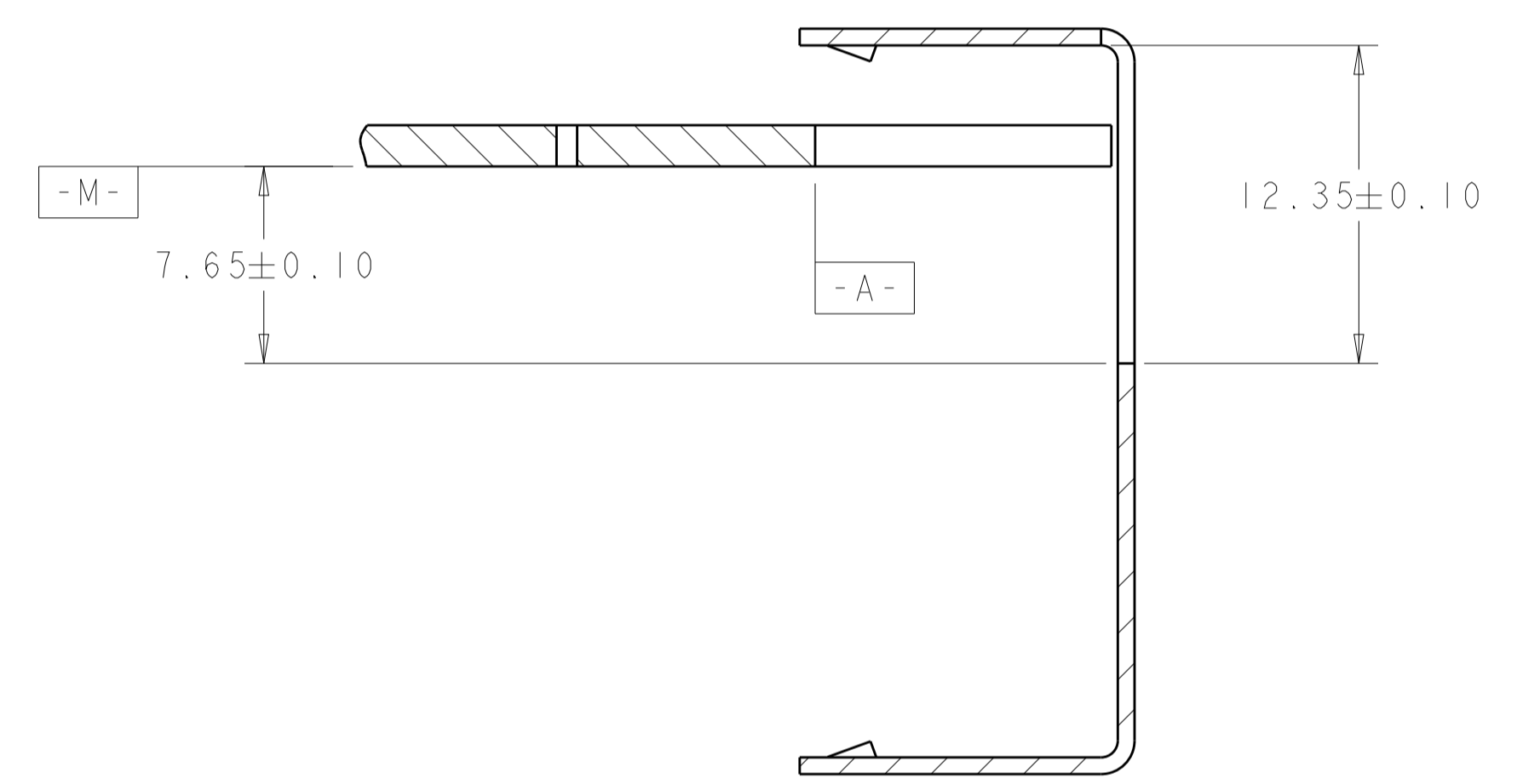

SECTION Y-Y

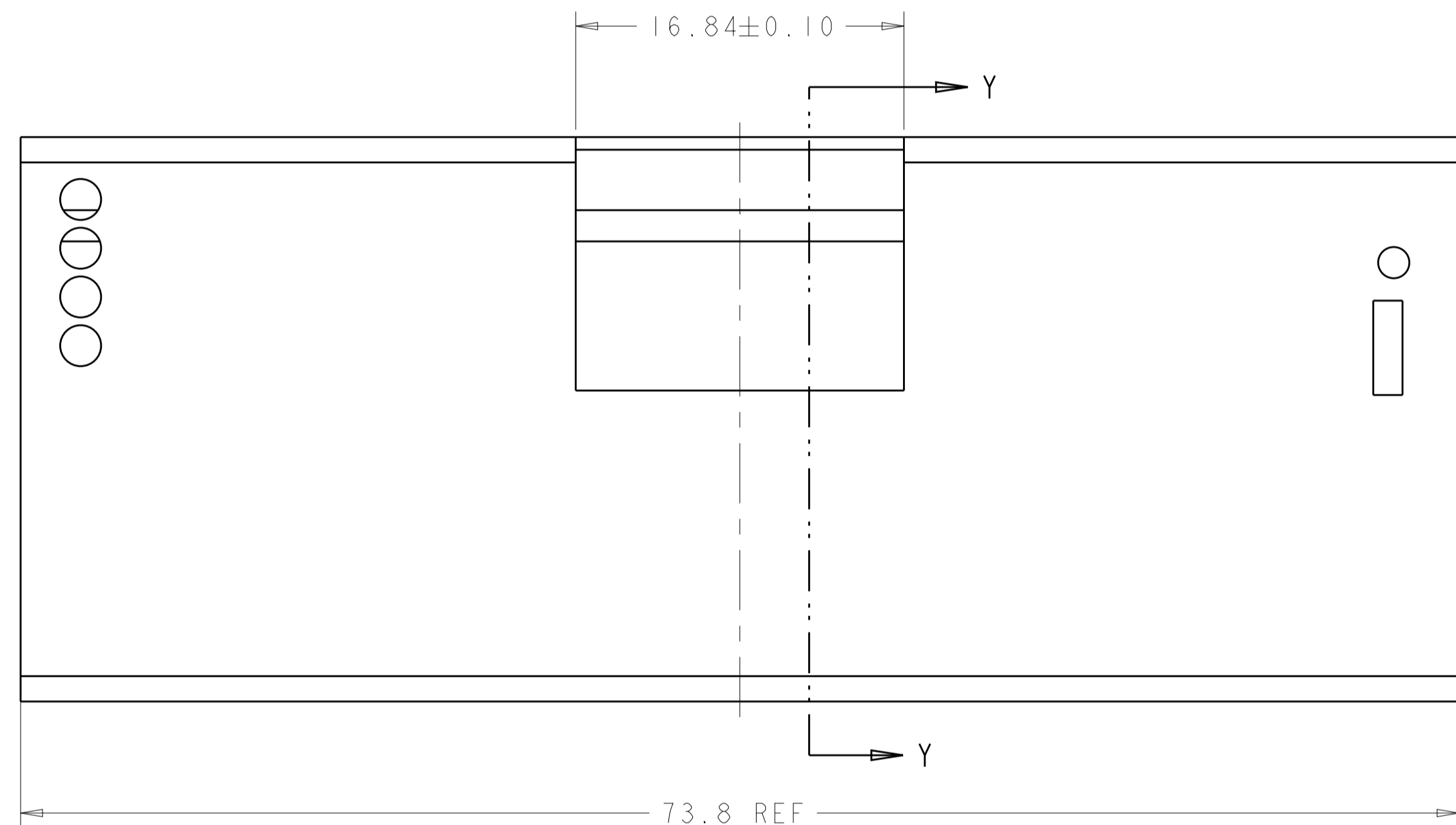

AMC SINGLE WIDTH, FULL HEIGHT MODULE FACE PLATE  
SCALE 4:1

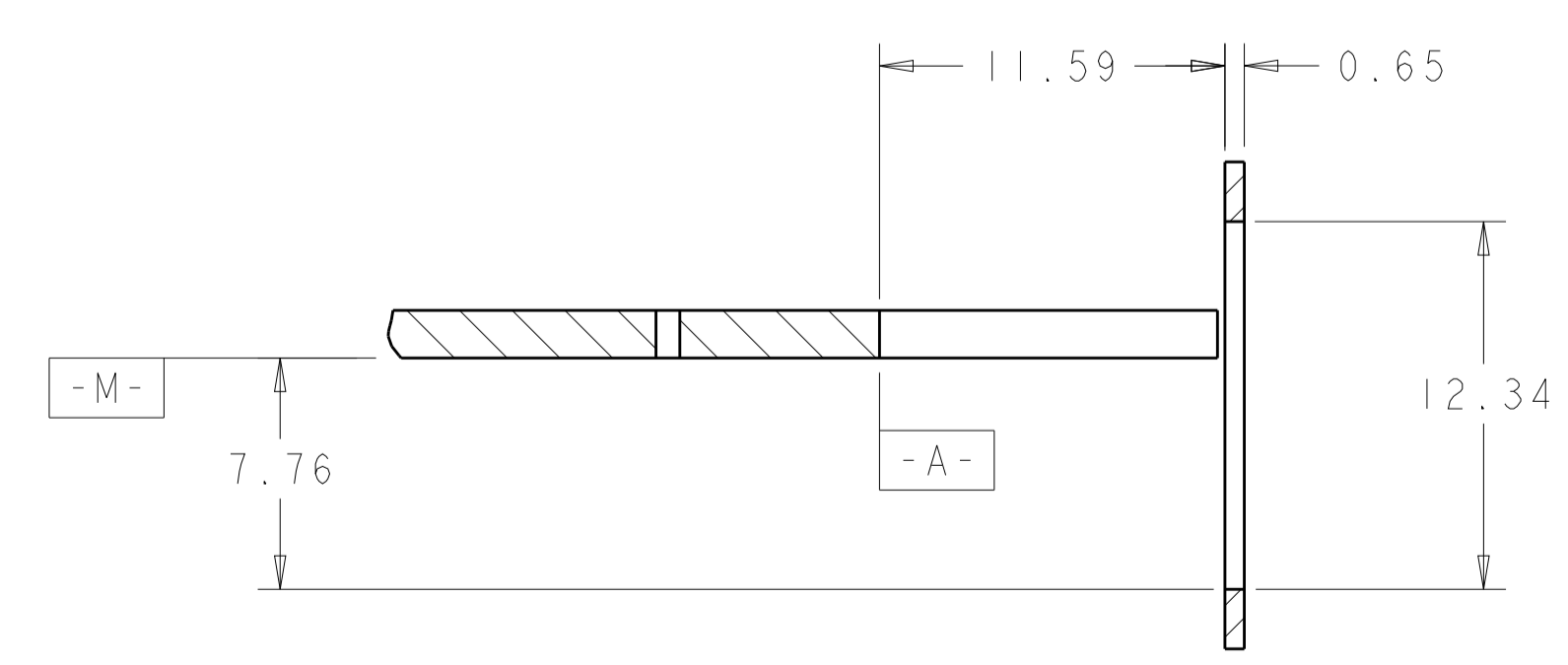

SECTION X-X

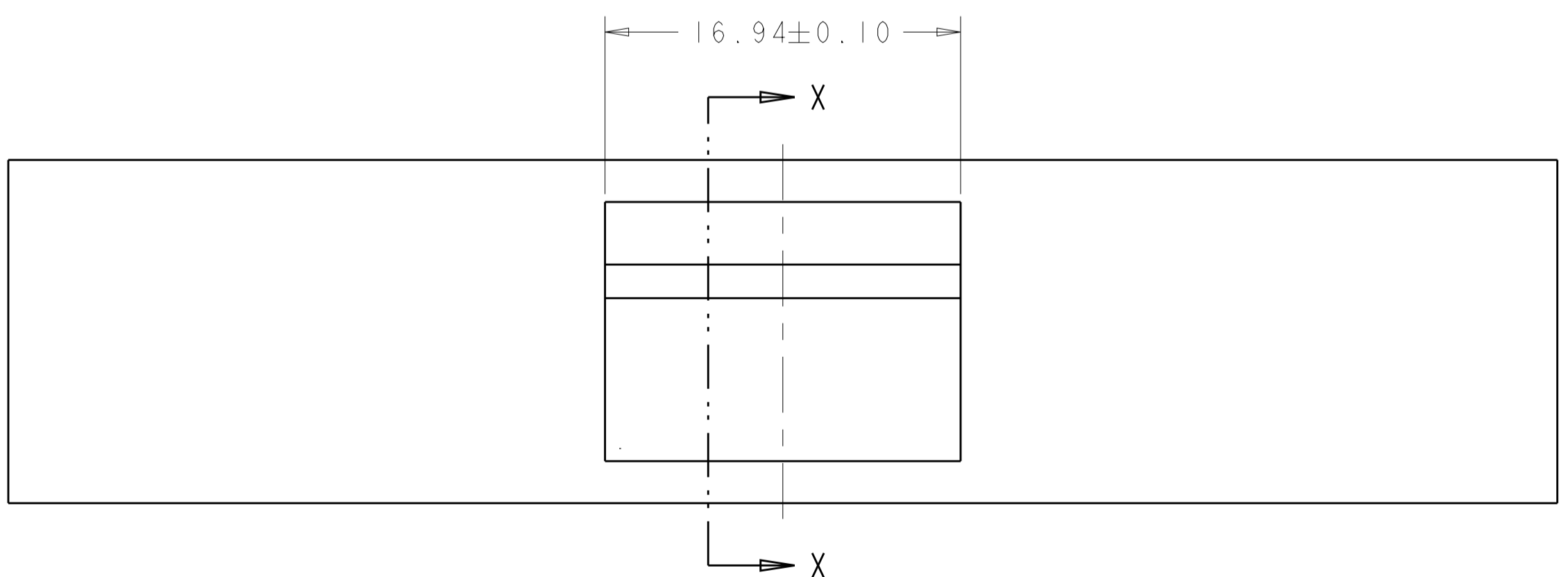

STANDARD FACE PLATE  
SCALE 4:1

THIS DRAWING IS A CONTROLLED DOCUMENT.		DMN: MS/L.A.MAYER 15FEB2008	TE Connectivity
DIMENSIONS: mm		CHK: J.WESTMAN 15FEB2008	
TOLERANCES UNLESS OTHERWISE SPECIFIED:		APVD: S.FLICKINGER 15FEB2008	NAME: CONNECTOR ASSEMBLY, LOW PROFILE, PRESS FIT, MODULAR JACK, IXI, RJ45 PRODUCT SPEC: 108-2274 APPLICATION SPEC: 114-13179
0 PLC ± 1 PLC ±0.13 2 PLC ± 3 PLC ± 4 PLC ± ANGLES ±°		SIZE: A1 CAGE CODE: 100779 DRAWING NO: C=1888250	
MATERIAL: SEE NOTE 1		FINISH: SEE NOTE 1	WEIGHT: - CUSTOMER DRAWING: - SCALE: 5:1 SHEET 3 OF 3 REV D