

NOTES:

- 1. MATERIALS AND FINISHES:
 BODY, NUT-HEX, LOCK WASHER &
 INNER BODY - BRASS, NICKEL PLATING
 CONTACT - BeCu, GOLD PLATING
 BULLET CONTACT - BRASS, GOLD PLATING
 INSULATOR - PTFE, NATURAL
 INSULATOR DISC - PEEK, NATURAL
 O-RING & GASKET - SILICONE RUBBER, RED
 FERRULE - COPPER, NICKEL PLATING
- 2. ELECTRICAL:
 A. IMPEDANCE: 50 OHM
 B. FREQUENCY RANGE: DC - 11 GHz
 C. VSWR: 1.20 MAX. @ DC - 6 GHz
 1.30 MAX. @ 6 - 11 GHz
 D. DIELECTRIC WITHSTANDING VOLTAGE: 1500 VRMS, MIN.
- 3. MECHANICAL:
 A. DURABILITY: 500 CYCLES MIN.
 B. TEMPERATURE RANGE: -65°C TO +165°C
 C. SEALING: MEETS IP-67 REQUIREMENTS IN UNMATED CONDITION.

- 4. PACKAGING:
 A. QUANTITY: SINGLE PACK
 B. MARKING: PACKAGING TO BE MARKED
 "AMPHENOL RF, 82-6764 AND DATE CODE"
- 5. CABLE ASSEMBLY INSTRUCTIONS:
 A. TRIM CABLE AS SHOWN.
 B. SLIDE FERRULE AND INSULATOR DISC ONTO CABLE.
 C. SOLDER CENTER CONDUCTOR TO BULLET CONTACT.
 D. INSERT CABLE INTO CONNECTOR UNTIL IT BOTTOMS
 AND BRAID OVER KNURL.
 E. CRIMP FERRULE OVER BRAID WITH .213" HEX DIE.

6 SHOWS CABLE ENTRY DIMENSIONS.

REVISIONS				
REV	DESCRIPTION	DATE	ECN	BY
A	RELEASE TO MFG.	15-Apr-22	16113	SH

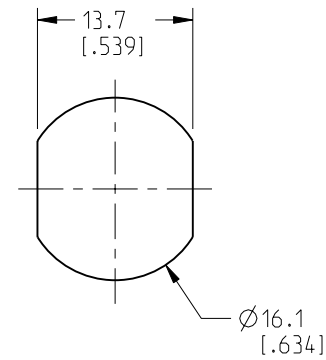

RECOMMENDED MOUNTING HOLE DIMENSIONS

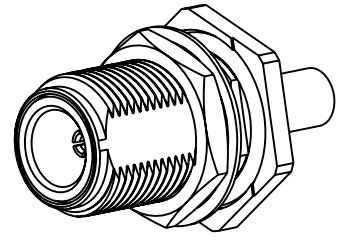

SCALE 1:200

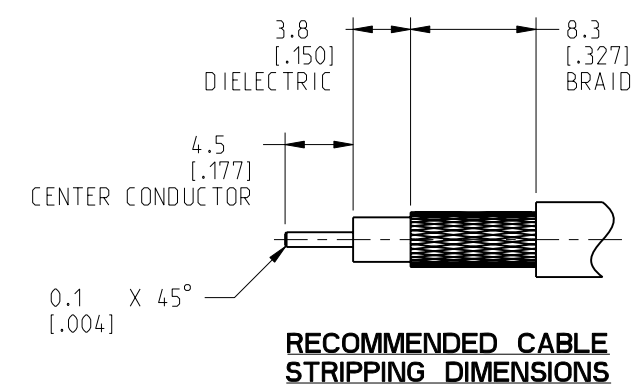

RECOMMENDED CABLE STRIPPING DIMENSIONS

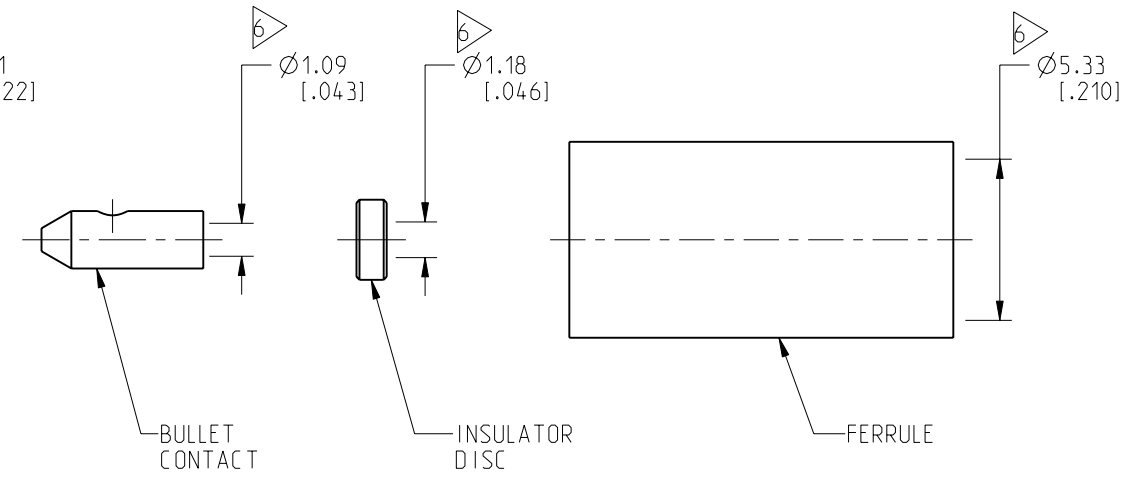
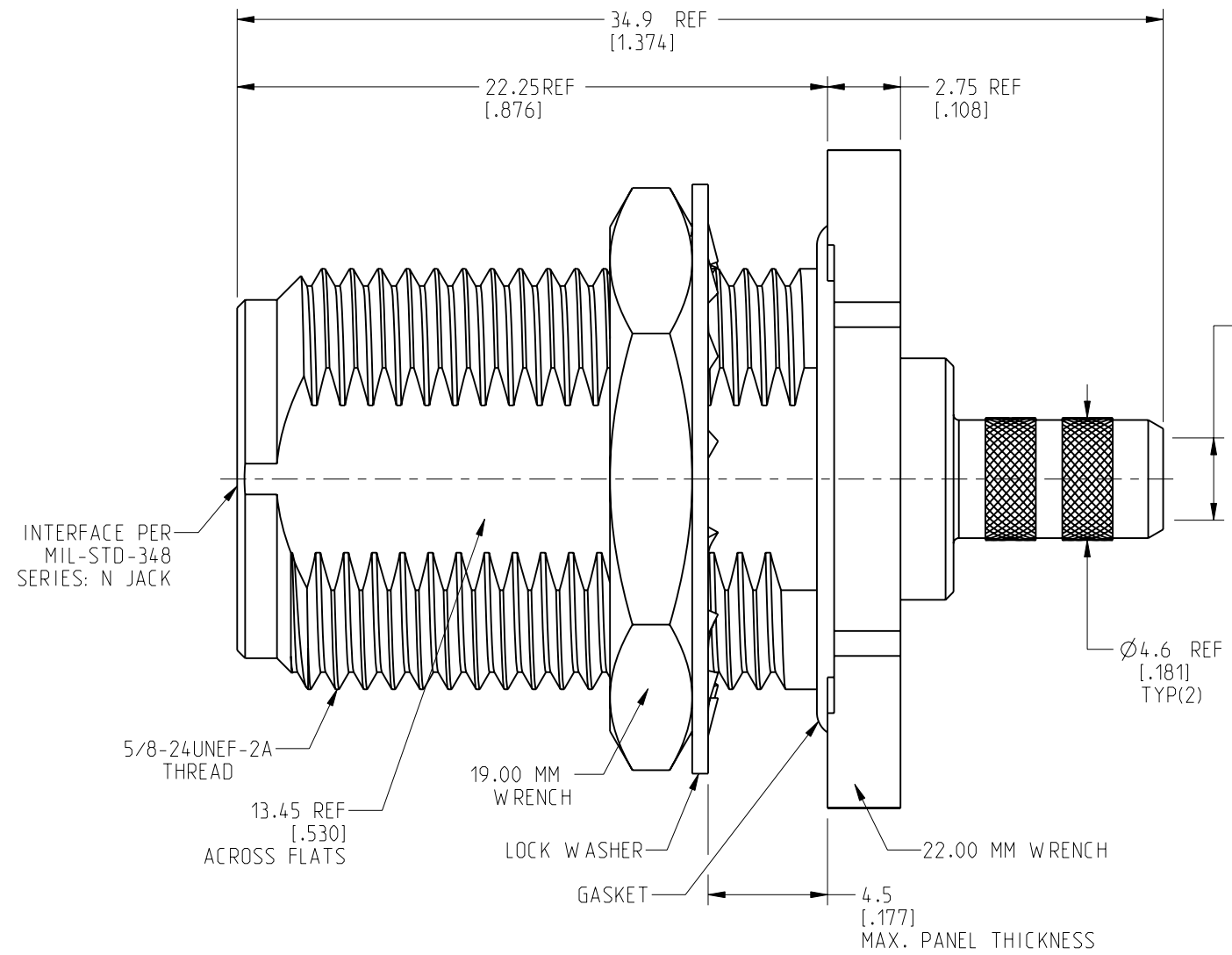

CUSTOMER OUTLINE DRAWING

ALL OTHER SHEETS ARE FOR INTERNAL USE ONLY

NOTICE: These drawings, specifications, or other data (1) are, and remain the property of Amphenol corp. (2) must be returned upon request; and (3) are confidential and not to be disclosed to any person other than those to whom they are given by Amphenol Corp. The furnishing of these drawings, specifications, or other data by Amphenol Corp., or to any other person to anyone for any purpose is not to be regarded by implication or otherwise in any manner licensing, granting rights to permitting such holder or any other person to manufacture, use or sell any product, process or design, patented or otherwise, that may in any way be related to or disclosed by said drawings, specifications, or other data.

THIRD ANGLE PROJ. REFERENCE EAR# 10072

UNLESS OTHERWISE SPECIFIED DIMENSIONS ARE METRIC (INCHES) AND TOLERANCES ARE:
 <0.5mm = ±0.05mm [$<0.020 = \pm 0.002$]
 0.5 - 6mm = ±0.1mm [$>0.020 - 0.236 = \pm 0.004$]
 >6.00 - 30mm = ±0.2mm [$>0.236 - 1.181 = \pm 0.008$]
 >30.00 - 120mm = ±0.3mm [$>1.181 - 4.725 = \pm 0.012$]

ANGLES = ±1°

MATERIAL SEE NOTES

ENGR.1 C.CROTTY ENGR.2 WIKI DATE 30-JUN-21

TITLE N STR BHD JACK IP 67 FOR RG 58 CABLE

SHEET NO. 2 OF 2 SCALE: 4.0:1.0

SIZE B	DRAWING NO. 82-6764	REV A
	ITEM NO. 82-6764	
	PART NO. 82-6764	