

REVISIONS					
P	LTR	DESCRIPTION	DATE	DWN	APVD
T2		REVISED PER ECO-16-004800	12SEP2016	NK	MZ
U		REVISED PER ECO-17-004657	05APR2017	RS	MZ
U1		REVISED PER ECO-17-015159	16OCT2017	RS	MZ
V		REVISED PER ECO-18-015539	04OCT2018	RS	MZ

- 1 POSTS WILL BE ORIENTED WITH SEAM TOWARD INK STAMPED EDGE, OR ROTATED 180°.
- 2 .000030 MIN GOLD FOR A LENGTH OF .200 MIN FROM MATING END, .000100 MIN TIN-LEAD FOR A LENGTH OF DIMENSION 'A' FROM OPPOSITE END, ALL OVER .000050 MIN NICKEL.
- 3 .000030 MIN GOLD FOR A LENGTH OF .200 MIN FROM MATING END, .000100 MIN TIN FOR A LENGTH OF DIMENSION 'A' FROM OPPOSITE END, ALL OVER .000050 MIN NICKEL.

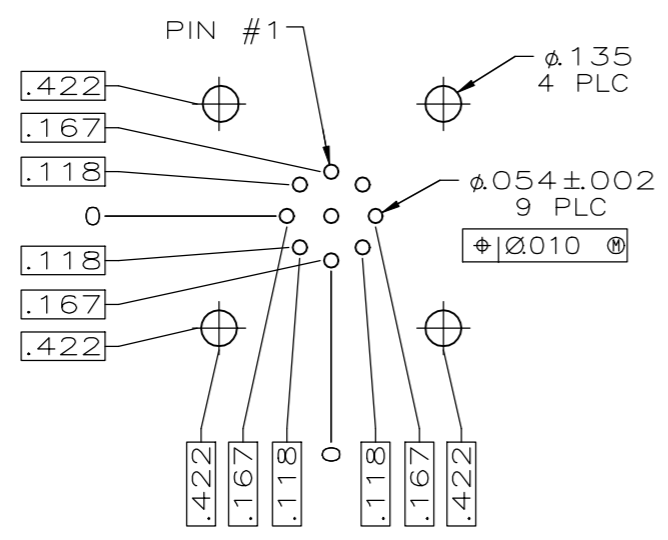
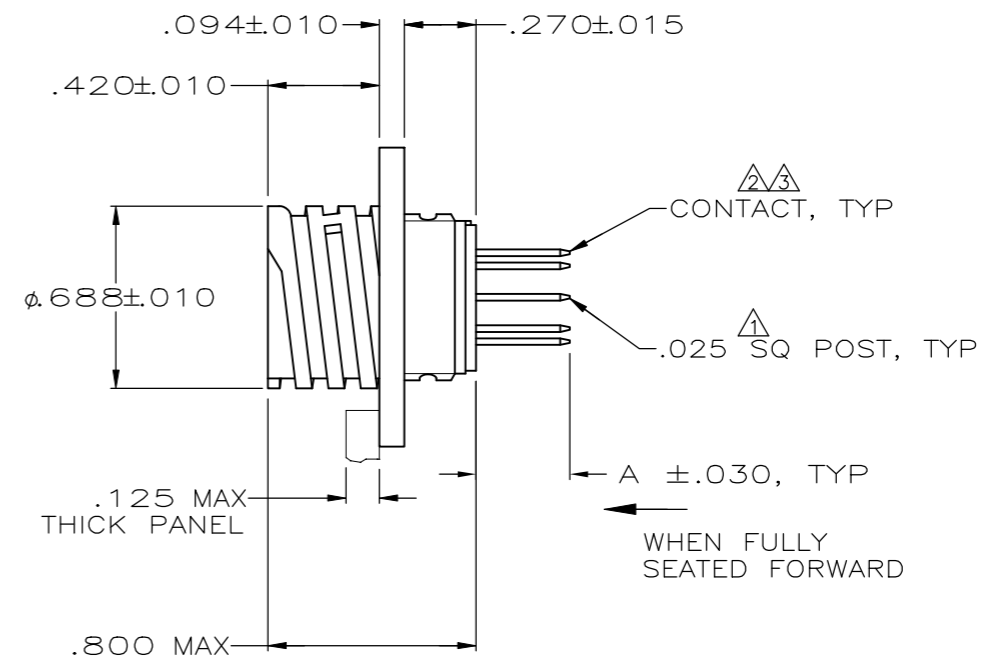
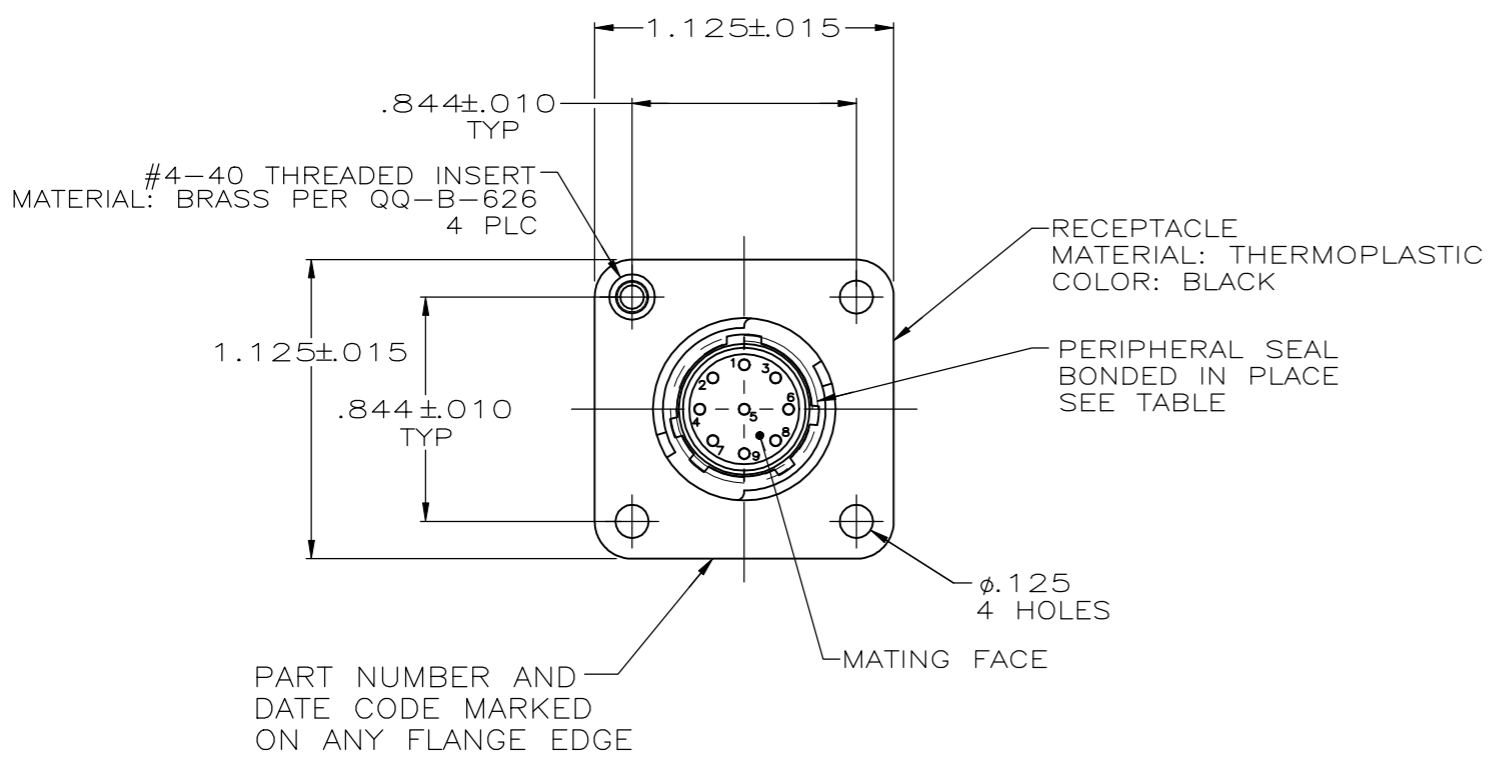

RECOMMENDED PC BOARD LAYOUT

	3	.125	NO	NO	1-206852-2
	3	.352	NO	NO	1-206852-1
OBSOLETE	2	.125	YES	YES	1-206852-0
OBSOLETE	2	.796	YES	YES	206852-9
	-	-	NO	YES	206852-8
OBSOLETE	2	-	NO	NO	206852-7
OBSOLETE	2	-	NO	NO	206852-6
OBSOLETE	2	-	NO	NO	206852-5
OBSOLETE	2	.352	NO	NO	206852-4
OBSOLETE	2	.574	NO	NO	206852-3
	2	.125	NO	NO	206852-2
OBSOLETE	2	.352	NO	NO	206852-1
		CONTACT FINISH	DIM A	PERIPHERAL SEAL	THREADED INSERTS
					PART NUMBER

THIS DRAWING IS A CONTROLLED DOCUMENT.

DWN: J. GALLUCCI BG 5-22-91  
 CHK: W.G. LENKER 4-13-92

TE Connectivity

RECEPTACLE ASSEMBLY, POSTED, STD SEX, SERIES 2, 11-9, CPC

PRODUCT SPEC: 108-10024

APPLICATION SPEC: -

SIZE: A2 CAGE CODE: 00779 DRAWING NO: C-206852

RESTRICTED TO: -

MATERIAL: SEE CALLOUT FINISH: - WEIGHT: -

CUSTOMER DRAWING SCALE: 2:1 SHEET: 1 of 1 REV: V