

## GENERAL DESCRIPTION

The 87972I is a low skew, LVCMOS/LVTTL Clock Generator. The 87972I has three selectable inputs and provides fourteen LVCMOS/LVTTL outputs.

The 87972I is a highly flexible device. Using the crystal oscillator input, it can be used to generate clocks for a system. All of these clocks can be the same frequency or the device can be configured to generate up to three different frequencies among the three output banks. Using one of the single ended inputs, the 87972I can be used as a zero delay buffer/multiplier/divider in clock distribution applications.

The three output banks and feedback output each have their own output dividers which allows the device to generate a multitude of different bank frequency ratios and output-to-input frequency ratios. In addition, 2 outputs in Bank C (QC2, QC3) can be selected to be inverting or non-inverting. The output frequency range is 8.33MHz to 125MHz. Input frequency range is 5MHz to 120MHz.

The 87972I also has a QSYNC output which can be used for system synchronization purposes. It monitors Bank A and Bank C outputs and goes low one period of the faster clock prior to coincident rising edges of Bank A and Bank C clocks. QSYNC then goes high again when the coincident rising edges of Bank A and Bank C occur. This feature is used primarily in applications where Bank A and Bank C are running at different frequencies, and is particularly useful when they are running at non-integer multiples of one another.

### Example Applications:

1. *System Clock generator:* Use a 16.66MHz Crystal to generate eight 33.33MHz copies for PCI and four 100MHz copies for the CPU or PCI-X.
2. *Line Card Multiplier:* Multiply 19.44MHz from a back plane to 77.76MHz for the line Card ASICs and Serdes.
3. *Zero Delay buffer for Synchronous memory:* Fan out up to twelve 100MHz copies from a memory controller reference clock to the memory chips on a memory module with zero delay.

## FEATURES

- Fully integrated PLL
- Fourteen LVCMOS/LVTTL outputs; (12) clocks, (1) feedback, (1) sync
- Selectable crystal oscillator interface or LVCMOS/LVTTL reference clock inputs
- CLK0, CLK1 can accept the following input levels: LVCMOS or LVTTL
- Output frequency range: 8.33MHz to 125MHz
- VCO range: 200MHz to 480MHz
- Output skew: 550ps (maximum)
- Cycle-to-cycle jitter: ±100ps (typical)
- Full 3.3V supply voltage
- -40°C to 85°C ambient operating temperature
- Available in lead-free RoHS-compliant package
- Compatible with PowerPC™ and Pentium™ Microprocessors

## PIN ASSIGNMENT

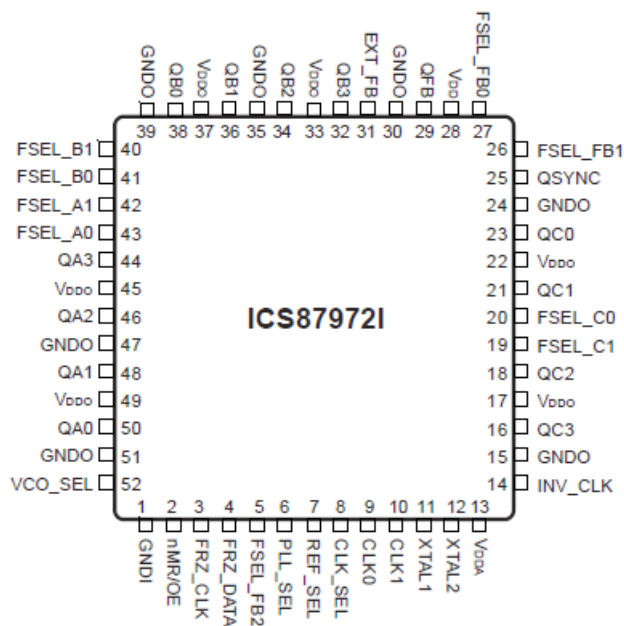

### 52-Lead LQFP

10mm x 10mm x 1.4mm package body

### Y package

Top View

# BLOCK DIAGRAM

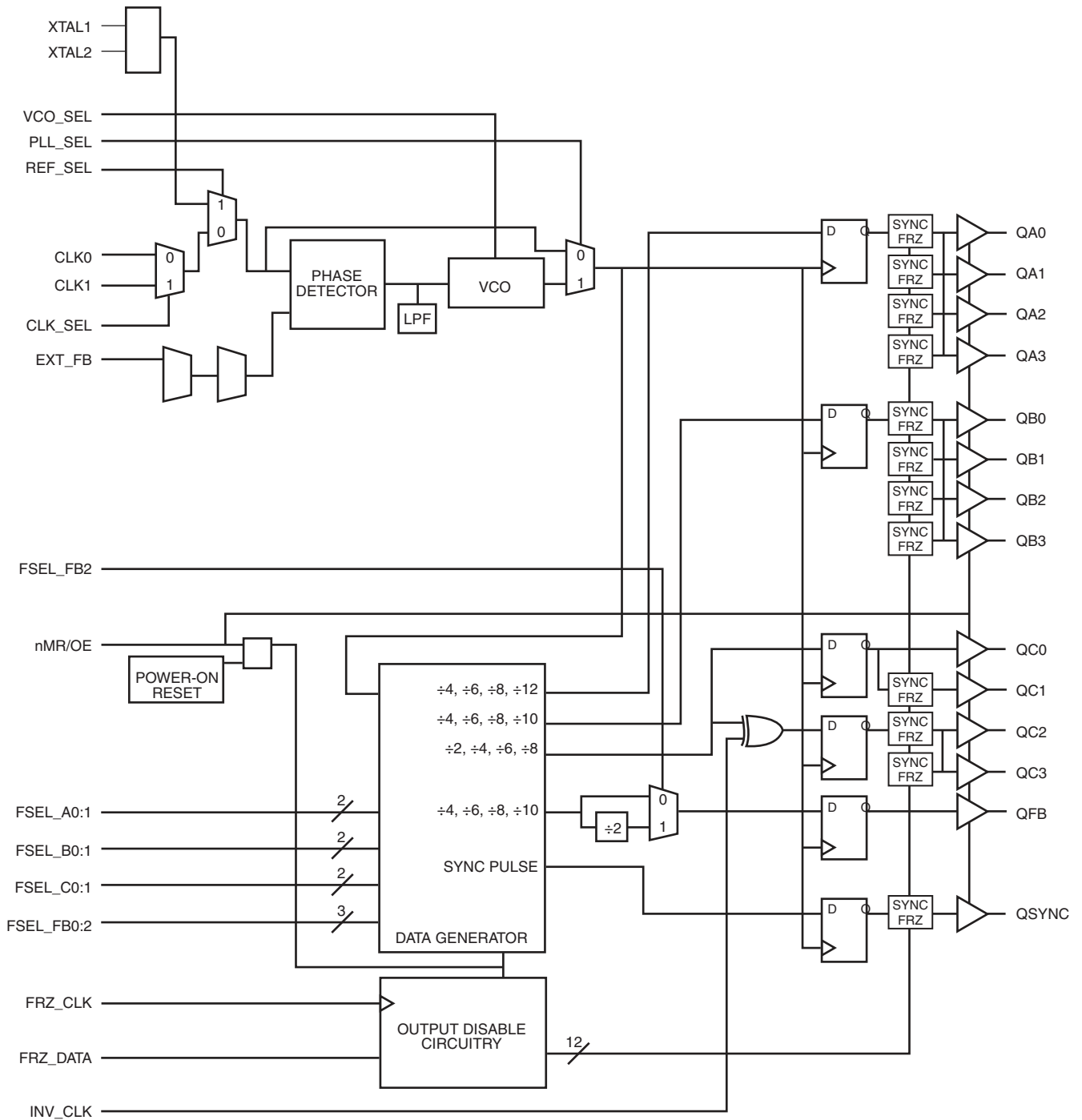

# SIMPLIFIED BLOCK DIAGRAM

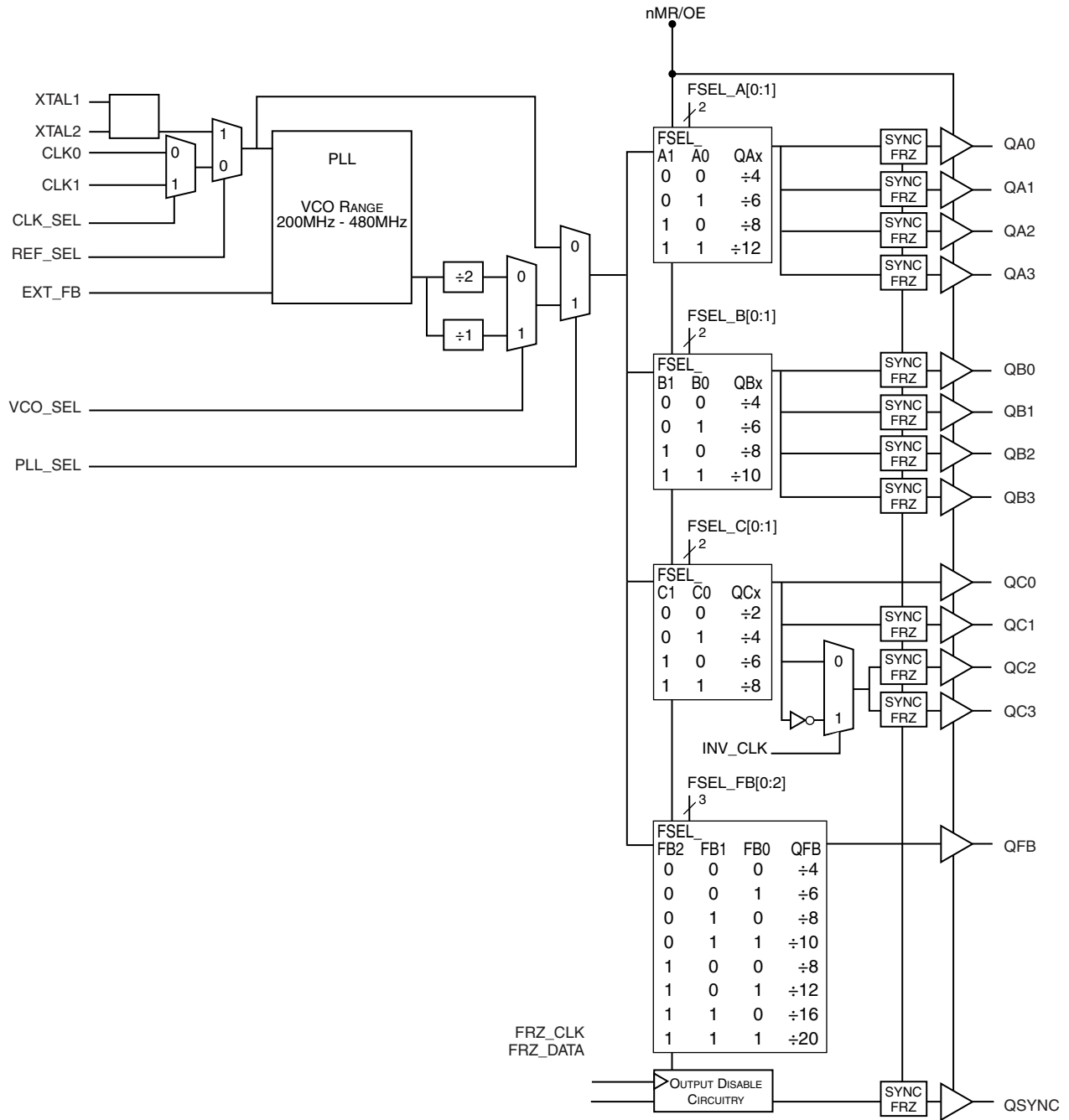

**TABLE 1. PIN DESCRIPTIONS**

Number	Name	Type		Description
1	GNDI	Power		Power supply ground.
2	nMR/OE	Input	Pullup	Active HIGH Master Reset. Active LOW output enable. When logic HIGH, the internal dividers are reset and the outputs are in high impedance (Hi-Z). When logic LOW, the internal dividers and the outputs are enabled. LVCMOS / LVTTTL interface levels.
3	FRZ_CLK	Input	Pullup	Clock input for freeze circuitry. LVCMOS / LVTTTL interface levels.
4	FRZ_DATA	Input	Pullup	Configuration data input for freeze circuitry. LVCMOS / LVTTTL interface levels.
5, 26, 27	FSEL_FB2, FSEL_FB1, FSEL_FB0	Input	Pullup	Select pins control Feedback Divide value. LVCMOS / LVTTTL interface levels.
6	PLL_SEL	Input	Pullup	Selects between the PLL and reference clocks as the input to the output dividers. When HIGH, selects PLL. When LOW, bypasses the PLL and reference clocks. LVCMOS / LVTTTL interface levels.
7	REF_SEL	Input	Pullup	Selects between crystal and reference clock. When LOW, selects CLK0 or CLK1. When HIGH, selects crystal inputs. LVCMOS / LVTTTL interface levels.
8	CLK_SEL	Input	Pullup	Clock select input. When LOW, selects CLK0. When HIGH, selects CLK1. LVCMOS / LVTTTL interface levels.
9, 10	CLK0, CLK1	Input	Pullup	Reference clock inputs. LVCMOS / LVTTTL interface levels.
11, 12	XTAL1, XTAL2	Input		Crystal oscillator interface. XTAL1 is the input. XTAL2 is the output.
13	V <sub>DDA</sub>	Power		Analog supply pin.
14	INV_CLK	Input	Pullup	Inverted clock select for QC2 and QC3 outputs. LVCMOS / LVTTTL interface levels.
15, 24, 30, 35, 39, 47, 51	GND0	Power		Power supply ground.
16, 18, 21, 23	QC3, QC2, QC1, QC0	Output		Bank C clock outputs. 7Ω typical output impedance. LVCMOS / LVTTTL interface levels.
17, 22, 33 37, 45, 49	V <sub>DDO</sub>	Power		Output supply pins.
19, 20	FSEL_C1, FSEL_C0	Input	Pullup	Select pins for Bank C outputs. LVCMOS / LVTTTL interface levels.
25	QSYNC	Output		Synchronization output for Bank A and Bank C. Refer to Figure 1, Timing Diagrams. LVCMOS / LVTTTL interface levels.
28	V <sub>DD</sub>	Power		Core supply pins.
29	QFB	Output		Feedback clock output. LVCMOS / LVTTTL interface levels.
31	EXT_FB	Input	Pullup	External feedback. LVCMOS / LVTTTL interface levels.
32, 34, 36, 38	QB3, QB2, QB1, QB0	Output		Bank B clock outputs. 7Ω typical output impedance. LVCMOS / LVTTTL interface levels.
40, 41	FSEL_B1, FSEL_B0	Input	Pullup	Select pins for Bank B outputs. LVCMOS / LVTTTL interface levels.
42, 43	FSEL_A1, FSEL_A0	Input	Pullup	Select pins for Bank A outputs. LVCMOS / LVTTTL interface levels.
44, 46, 48, 50	QA3, QA2, QA1, QA0	Output		Bank A clock outputs. 7Ω typical output impedance. LVCMOS / LVTTTL interface levels.
52	VCO_SEL	Input	Pullup	Selects VCO. When HIGH, selects VCO ÷ 1. When LOW, selects VCO ÷ 2. LVCMOS / LVTTTL interface levels.

NOTE: refers to internal input resistors. See table 2, Pin Characteristics, for typical values.

**TABLE 2. PIN CHARACTERISTICS**

Symbol	Parameter	Test Conditions	Minimum	Typical	Maximum	Units
$C_{IN}$	Input Capacitance			4		pF
$R_{PULLUP}$	Input Pullup Resistor			51		k $\Omega$
$C_{PD}$	Power Dissipation Capacitance (per output)	$V_{DDA}, V_{DD}, V_{DDO} = 3.465V$			18	pF
$R_{OUT}$	Output Impedance		5	7	12	$\Omega$

**TABLE 3A. OUTPUT BANK CONFIGURATION SELECT FUNCTION TABLE**

Inputs		Outputs	Inputs		Outputs	Inputs		Outputs
FSEL_A1	FSEL_A0	QA	FSEL_B1	FSEL_B0	QB	FSEL_C1	FSEL_C0	QC
0	0	$\div 4$	0	0	$\div 4$	0	0	$\div 2$
0	1	$\div 6$	0	1	$\div 6$	0	1	$\div 4$
1	0	$\div 8$	1	0	$\div 8$	1	0	$\div 6$
1	1	$\div 12$	1	1	$\div 10$	1	1	$\div 8$

**TABLE 3B. FEEDBACK CONFIGURATION SELECT FUNCTION TABLE**

Inputs			Outputs
FSEL_FB2	FSEL_FB1	FSEL_FB0	QFB
0	0	0	$\div 4$
0	0	1	$\div 6$
0	1	0	$\div 8$
0	1	1	$\div 10$
1	0	0	$\div 8$
1	0	1	$\div 12$
1	1	0	$\div 16$
1	1	1	$\div 20$

**TABLE 3C. CONTROL INPUT SELECT FUNCTION TABLE**

Control Pin	Logic 0	Logic 1
VCO_SEL	VCO/2	VCO
REF_SEL	CLK0 or CLK1	XTAL
CLK_SEL	CLK0	CLK1
PLL_SEL	BYPASS PLL	Enable PLL
nMR/OE	Master Reset/Output Hi Z	Enable Outputs
INV_CLK	Non-Inverted QC2, QC3	Inverted QC2, QC3

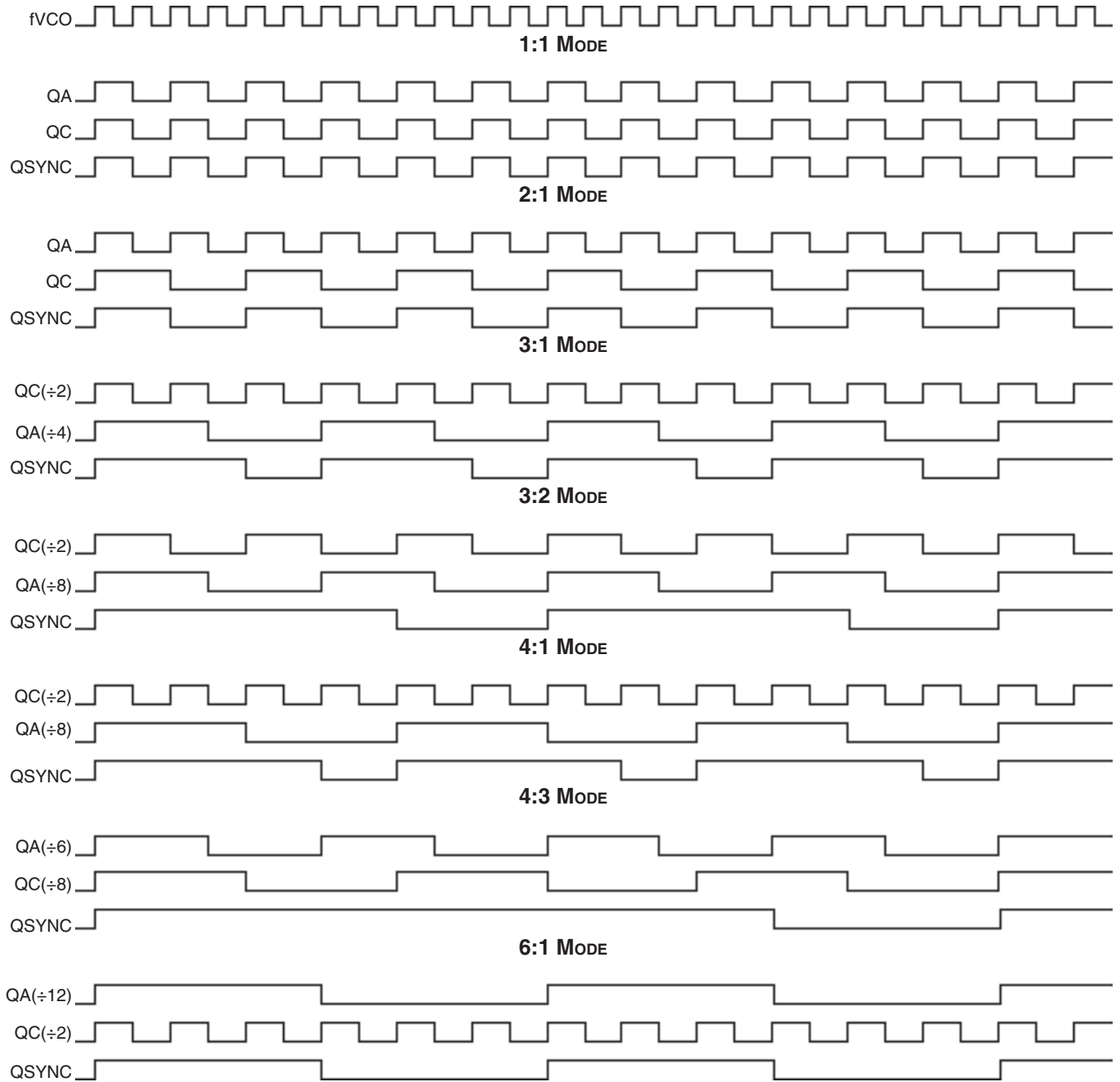

FIGURE 1. TIMING DIAGRAMS

**ABSOLUTE MAXIMUM RATINGS**

Supply Voltage, $V_{DD}$	4.6V
Inputs, $V_I$	-0.5V to $V_{DD} + 0.5V$
Outputs, $V_O$	-0.5V to $V_{DDO} + 0.5V$
Package Thermal Impedance, $\theta_{JA}$	42.3°C/W (0 lfpm)
Storage Temperature, $T_{STG}$	-65°C to 150°C

NOTE: Stresses beyond those listed under Absolute Maximum Ratings may cause permanent damage to the device. These ratings are stress specifications only. Functional operation of product at these conditions or any conditions beyond those listed in the *DC Characteristics* or *AC Characteristics* is not implied. Exposure to absolute maximum rating conditions for extended periods may affect product reliability.

**TABLE 4A. POWER SUPPLY DC CHARACTERISTICS,  $V_{DD} = V_{DDA} = V_{DDO} = 3.3V \pm 5\%$ ,  $T_A = -40^\circ\text{C}$  TO  $85^\circ\text{C}$** 

Symbol	Parameter	Test Conditions	Minimum	Typical	Maximum	Units
$V_{DD}$	Core Supply Voltage		3.135	3.3	3.465	V
$V_{DDA}$	Analog Supply Voltage		2.935	3.3	3.465	V
$V_{DDO}$	Output Supply Voltage		3.135	3.3	3.465	V
$I_{DD}$	Power Supply Current	All power pins			250	mA
$I_{DDA}$	Analog Supply Current				20	mA

NOTE: Special thermal handling may be required in some configurations.

**TABLE 4B. LVCMOS/LVTTL DC CHARACTERISTICS,  $V_{DD} = V_{DDA} = V_{DDO} = 3.3V \pm 5\%$ ,  $T_A = -40^\circ\text{C}$  TO  $85^\circ\text{C}$** 

Symbol	Parameter	Test Conditions	Minimum	Typical	Maximum	Units
$V_{IH}$	Input High Voltage		2		3.6	V
$V_{IL}$	Input Low Voltage				0.8	V
$I_{IN}$	Input Current				$\pm 120$	$\mu\text{A}$
$V_{OH}$	Output High Voltage	$I_{OH} = -20\text{mA}$	2.4			V
$V_{OL}$	Output Low Voltage	$I_{OL} = 20\text{mA}$			0.5	V

**TABLE 5. INPUT FREQUENCY CHARACTERISTICS,  $V_{DD} = V_{DDA} = V_{DDO} = 3.3V \pm 5\%$ ,  $T_A = -40^\circ\text{C}$  TO  $85^\circ\text{C}$** 

Symbol	Parameter	Test Conditions	Minimum	Typical	Maximum	Units
$f_{IN}$	Input Frequency	CLK0, CLK1; NOTE 1			120	MHz
		XTAL1, XTAL2	10		25	MHz
		FRZ_CLK			20	MHz

NOTE 1: Input frequency depends on the feedback divide ratio to ensure "clock \* feedback divide" is in the VCO range of 200MHz to 480MHz.

**TABLE 6. CRYSTAL CHARACTERISTICS,  $V_{DD} = V_{DDA} = V_{DDO} = 3.3V \pm 5\%$ ,  $T_A = -40^\circ\text{C}$  TO  $85^\circ\text{C}$** 

Parameter	Test Conditions	Minimum	Typical	Maximum	Units
Mode of Oscillation		Fundamental			
Frequency		10		25	MHz
Equivalent Series Resistance (ESR)				50	$\Omega$
Shunt Capacitance				7	pF
Drive Level				1	mW

**TABLE 7. AC CHARACTERISTICS,  $V_{DD} = V_{DDA} = V_{DDO} = 3.3V \pm 5\%$ ,  $T_A = -40^\circ\text{C}$  TO  $85^\circ\text{C}$** 

Symbol	Parameter	Test Conditions	Minimum	Typical	Maximum	Units	
$f_{MAX}$	Output Frequency	$\div 2$			125	MHz	
		$\div 4$			120	MHz	
		$\div 6$			80	MHz	
		$\div 8$			60	MHz	
$t(\emptyset)$	Static Phase Offset; NOTE 1	CLK0	QFB $\div 8$	-270	130	530	ps
		CLK1	In Frequency = 50MHz	-330	70	470	ps
$t_{sk(o)}$	Output Skew; NOTE 2, 4				550	ps	
$t_{jit(cc)}$	Cycle-to-Cycle Jitter; NOTE 4			$\pm 100$		ps	
$f_{VCO}$	PLL VCO Lock Range		200		480	MHz	
$t_{LOCK}$	PLL Lock Time; NOTE 3				10	ms	
$t_R / t_F$	Output Rise/Fall Time; NOTE 3	0.8V to 2V	0.15		1.2	ns	
$t_{PW}$	Output Pulse Width		$t_{PERIOD}/2 - 750$	$t_{PERIOD}/2 \pm 500$	$t_{PERIOD}/2 + 750$	ps	
$t_{PZL}, t_{PZH}$	Output Enable Time; NOTE 3				10	ns	
$t_{PLZ}, t_{PHZ}$	Output Disable Time; NOTE 3				8	ns	

NOTE 1: Defined as the time difference between the input reference clock and the average feedback input signal when the PLL is locked and the input reference frequency is stable.

NOTE 2: Defined as skew between outputs at the same supply voltage and with equal load conditions. Measured at  $V_{DDO}/2$ .

NOTE 3: These parameters are guaranteed by characterization. Not tested in production.

NOTE 4: This parameter is defined in accordance with JEDEC Standard 65.



# PARAMETER MEASUREMENT INFORMATION

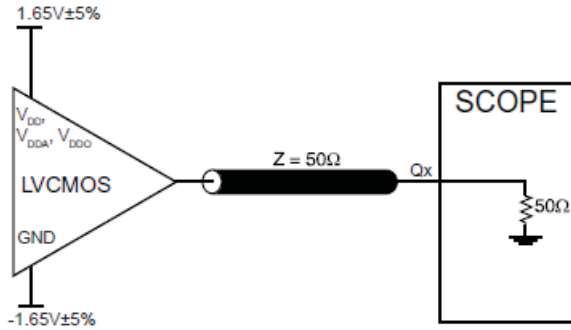

**3.3V OUTPUT LOAD AC TEST CIRCUIT**

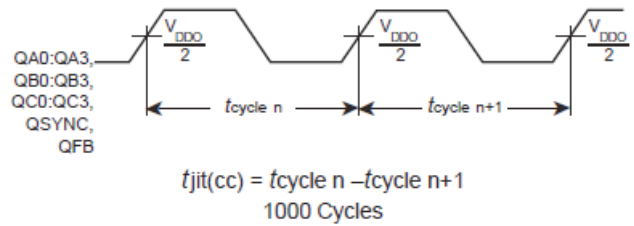

**CYCLE-TO-CYCLE JITTER**

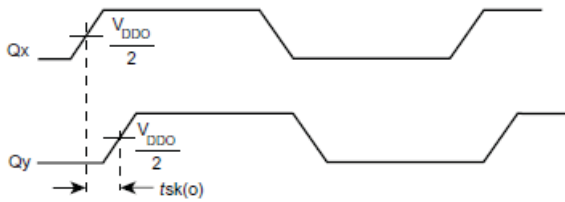

**OUTPUT SKEW**

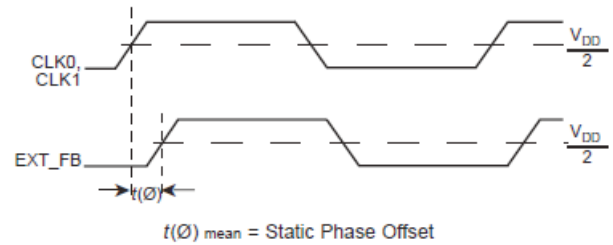

**STATIC PHASE OFFSET**

$t(\emptyset)_{\text{mean}} = \text{Static Phase Offset}$   
 (where  $t(\emptyset)$  is any random sample, and  $t(\emptyset)_{\text{mean}}$  is the average of the sampled cycles measured on controlled edges)

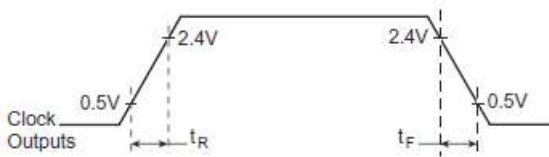

**OUTPUT RISE/FALL TIME**

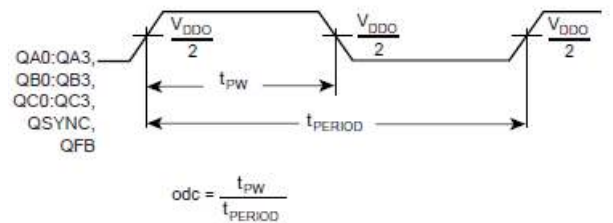

**OUTPUT DUTY CYCLE/PULSE WIDTH/PERIOD**

$$\text{odc} = \frac{t_{\text{PW}}}{t_{\text{PERIOD}}}$$

## APPLICATION INFORMATION

### USING THE OUTPUT FREEZE CIRCUITRY

#### OVERVIEW

To enable low power states within a system, each output of 87972I (Except QC0 and QFB) can be individually frozen (stopped in the logic “0” state) using a simple serial interface to a 12 bit shift register. A serial interface was chosen to eliminate the need for each output to have its own Output Enable pin, which would dramatically increase pin count and package cost. Common sources in a system that can be used to drive the 87972I serial interface are FPGA’s and ASICs.

#### PROTOCOL

The Serial interface consists of two pins, FRZ\_Data (Freeze Data) and FRZ\_CLK (Freeze Clock). Each of the outputs which can be frozen has its own freeze enable bit in the 12 bit shift register. The sequence is started by supplying a logic “0” start bit followed by 12NRZ freeze enable bits. The period of each FRZ\_DATA bit equals the period of the FRZ\_CLK signal. The FRZ\_DATA serial transmission should be timed so the 87972I can sample each FRZ\_DATA bit with the rising edge of the

FRZ\_CLK signal. To place an output in the freeze state, a logic “0” must be written to the respective freeze enable bit in the shift register. To unfreeze an output, a logic “1” must be written to the respective freeze enable bit. Outputs will not become enabled/disabled until all 12 data bits are shifted into the shift register. When all 12 data bits are shifted in the register, the next rising edge of FRZ\_CLK will enable or disable the outputs. If the bit that is following the 12th bit in the register is a logic “0”, it is used for the start bit of the next cycle; otherwise, the device will wait and won’t start the next cycle until it sees a logic “0” bit. Freezing and unfreezing of the output clock is synchronous (see the timing diagram below). When going into a frozen state, the output clock will go LOW at the time it would normally go LOW, and the freeze logic will keep the output low until unfrozen. Likewise, when coming out of the frozen state, the output will go HIGH only when it would normally go HIGH. This logic, therefore, prevents runt pulses when going into and out of the frozen state.

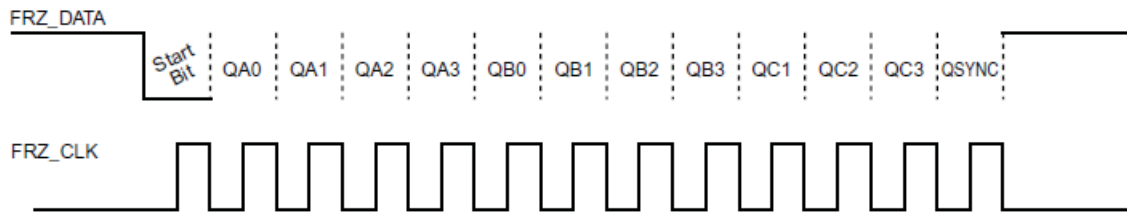

FIGURE 2A. FREEZE DATA INPUT PROTOCOL

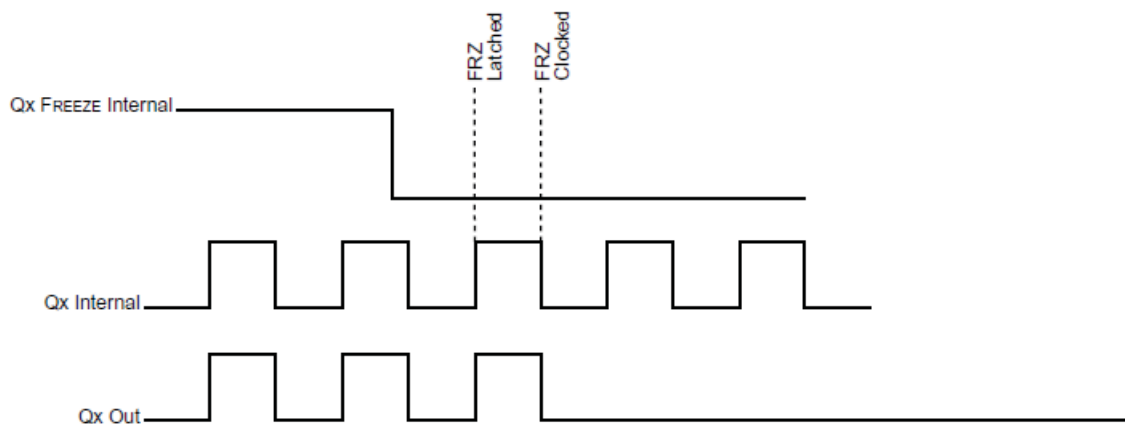

FIGURE 2B. OUTPUT DISABLE TIMING

## POWER SUPPLY FILTERING TECHNIQUES

As in any high speed analog circuitry, the power supply pins are vulnerable to random noise. The 87972I provides separate power supplies to isolate any high switching noise from the outputs to the internal PLL.  $V_{DD}$ ,  $V_{DDA}$  and  $V_{DDO}$  should be individually connected to the power supply plane through vias, and bypass capacitors should be used for each pin. To achieve optimum jitter performance, power supply isolation is required. *Figure 3* illustrates how a  $10\Omega$  resistor along with a  $10\mu\text{F}$  and a  $.01\mu\text{F}$  bypass capacitor should be connected to each  $V_{DDA}$  pin.

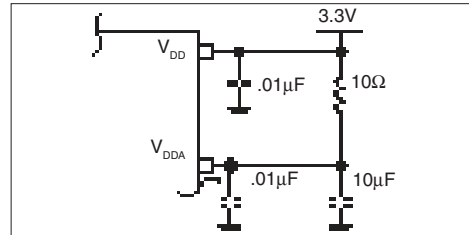

FIGURE 3. POWER SUPPLY FILTERING

## RECOMMENDATIONS FOR UNUSED INPUT AND OUTPUT PINS

### INPUTS:

#### CRYSTAL INPUT:

For applications not requiring the use of the crystal oscillator input, both XTAL\_IN and XTAL\_OUT can be left floating. Though not required, but for additional protection, a  $1\text{k}\Omega$  resistor can be tied from XTAL\_IN to ground.

#### CLK INPUT:

For applications not requiring the use of a clock input, it can be left floating. Though not required, but for additional protection, a  $1\text{k}\Omega$  resistor can be tied from the CLK input to ground.

#### LVC MOS CONTROL PINS:

All control pins have internal pull-ups or pull-downs; additional resistance is not required but can be added for additional protection. A  $1\text{k}\Omega$  resistor can be used.

### OUTPUTS:

#### LVC MOS OUTPUT:

All unused LVC MOS output can be left floating. We recommend that there is no trace attached.

### APPLICATION SCHEMATIC EXAMPLE

Figure 4 shows an application schematic example of 87972I. This example provides general handling of input/output termination, logic control input and power supply filtering. In this example, the clock inputs are driven by LVCMOS drivers. Series termination for LVCMOS drivers is shown. Additional LVCMOS termination approaches are shown in the LVCMOS Termination Application Note. The logic control input can be either hardwired

on the board or controlled by LVCMOS drivers. In this example, both hardwired and LVCMOS driver controlling the logic input are shown. For the power supply pins, it is recommended at least one decoupling capacitor per power pin. The decoupling capacitors should be placed as close to the power pins as possible.

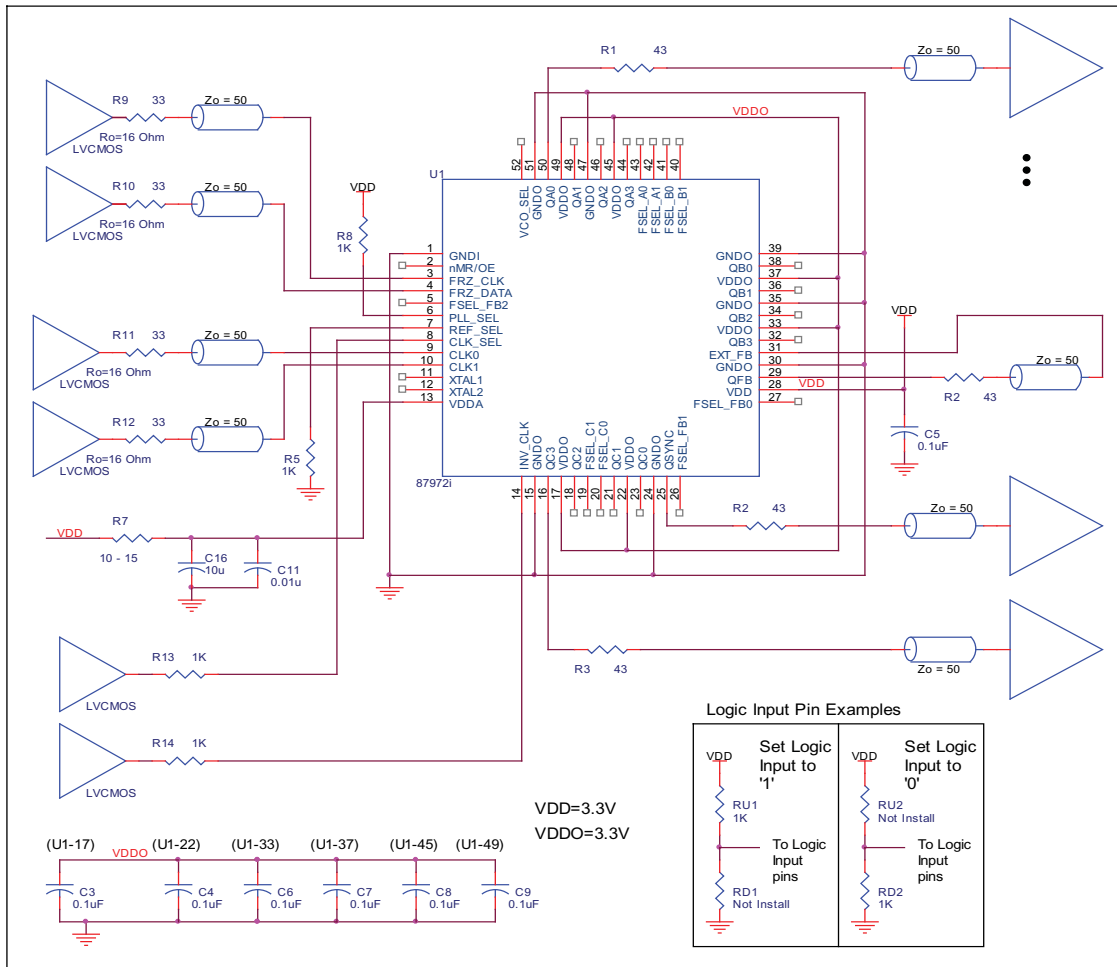

FIGURE 4. 87972I LAYOUT SCHEMATIC

## RELIABILITY INFORMATION

TABLE 8.  $\theta_{JA}$  VS. AIR FLOW TABLE FOR 52 LEAD LQFP

$\theta_{JA}$ by Velocity (Linear Feet per Minute)			
	0	200	500
Single-Layer PCB, JEDEC Standard Test Boards	58.0°C/W	47.1°C/W	42.0°C/W
Multi-Layer PCB, JEDEC Standard Test Boards	42.3°C/W	36.4°C/W	34.0°C/W

**NOTE:** Most modern PCB designs use multi-layered boards. The data in the second row pertains to most designs.

### TRANSISTOR COUNT

The transistor count for 87972I is: 8364

PACKAGE OUTLINE - Y SUFFIX FOR 52 LEAD LQFP

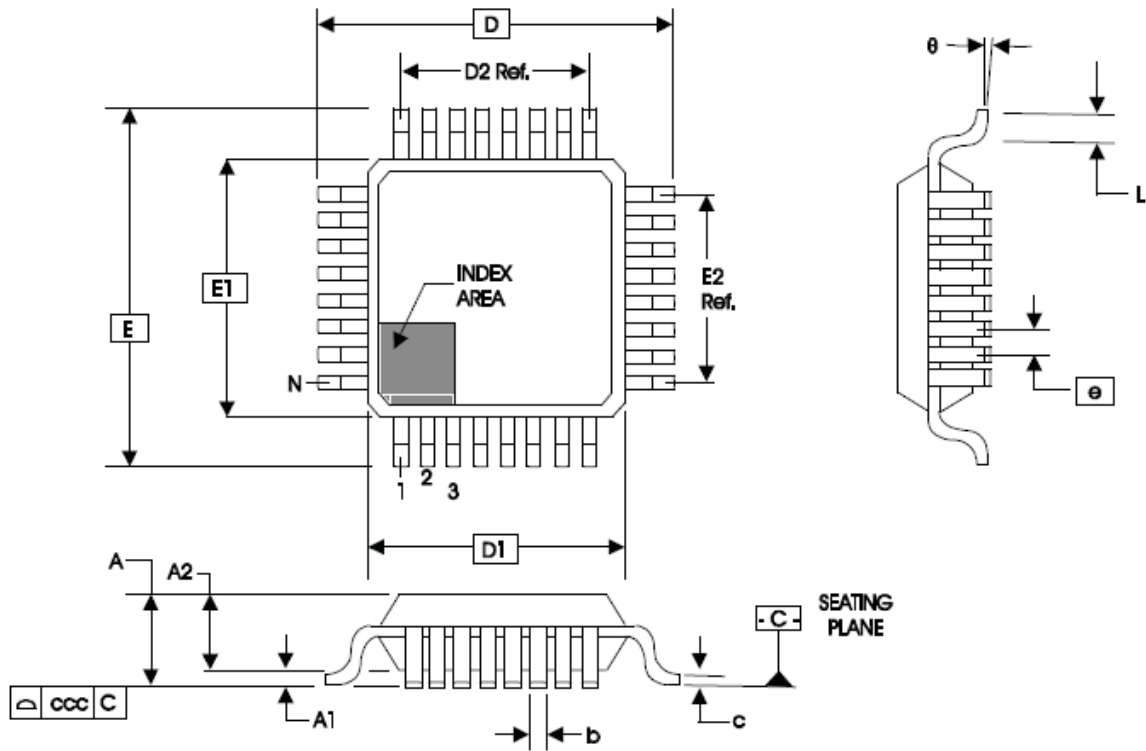

TABLE 9. PACKAGE DIMENSIONS

JEDEC VARIATION ALL DIMENSIONS IN MILLIMETERS			
SYMBOL	BCC		
	MINIMUM	NOMINAL	MAXIMUM
N	52		
A	--	--	1.60
A1	0.05	--	0.15
A2	1.35	1.40	1.45
b	0.22	0.32	0.38
b1	0.22	0.30	0.33
D	12.00 BASIC		
D1	10.00 BASIC		
E	12.00 BASIC		
E1	10.00 BASIC		
e	0.65 BASIC		
ccc	0.45	--	0.10
ddd	--	--	0.13

Reference Document: JEDEC Publication 95, MS-026

**TABLE 10. ORDERING INFORMATION**

Part/Order Number	Marking	Package	Shipping Packaging	Temperature
87972DYILF	ICS87972DYILF	52 lead "Lead Free" LQFP	Tray	-40°C to +85°C
87972DYILFT	ICS87972DYILF	52 lead "Lead Free" LQFP	Tape and Reel	-40°C to +85°C

REVISION HISTORY SHEET				
Rev	Table	Page	Description of Change	Date
A	1	4	Pin Description Table - added pins 20 and 21.	9/9/02
A		2	Block Diagram - added missing dividers to the Data Generator.	10/18/02
A		12	Revised Package Outline diagram.	12/5/02
B	T2 T4A	5	Pin Characteristics - changed the $C_{PD}$ limit from 25pF typical to 18pf max.	3/24/03
		7	Power Supply Table - changed the $I_{DD}$ limit from 215mA max. to 250mA max.	
		11	Application Information: Added section, "Power Supply Filtering Techniques".	
B	T2	5	Pin Characteristics - changed $C_{IN}$ from 4pF max. to 4pF typical.	5/8/03
		10	Corrected Freeze Data labeling on Figure 2A.	
C	T4A T6	7	Power Supply Table - changed minimum $V_{DDA}$ from 3.135V to 2.935V.	6/27/03
		8	Crystal Table - changed ESR from 80Ω to 50Ω.	
C		11	Added Schematic Layout.	12/28/04
D	T2 T6 T10	1	Features Section - add lead-free bullet.	11/29/05
		5	Pin Characteristics table - added 5Ω min. and 12Ω max to $R_{OUT}$ .	
		8	Crystal Characteristics table - added Drive Level.	
		11	Added <i>Recommendations for Unused Input and Output Pins</i> .	
D	T10	15	Updated datasheet's header/footer with IDT from ICS.	6/25/10
		16	Removed "ICS" prefix from Part/Order Number column.	
		17	Added Contact Page.	
E	T10	1	Removed ICS from part numbers where needed.	1/25/16
		14	Features section - removed reference to leaded package.	
		15	Ordering Information - removed quantity from tape and reel. Deleted note below the table. Revision History - Corrected from Rev C to Rev D for 6/25/10. Updated header and footer.	





## IMPORTANT NOTICE AND DISCLAIMER

RENESAS ELECTRONICS CORPORATION AND ITS SUBSIDIARIES (“RENESAS”) PROVIDES TECHNICAL SPECIFICATIONS AND RELIABILITY DATA (INCLUDING DATASHEETS), DESIGN RESOURCES (INCLUDING REFERENCE DESIGNS), APPLICATION OR OTHER DESIGN ADVICE, WEB TOOLS, SAFETY INFORMATION, AND OTHER RESOURCES “AS IS” AND WITH ALL FAULTS, AND DISCLAIMS ALL WARRANTIES, EXPRESS OR IMPLIED, INCLUDING, WITHOUT LIMITATION, ANY IMPLIED WARRANTIES OF MERCHANTABILITY, FITNESS FOR A PARTICULAR PURPOSE, OR NON-INFRINGEMENT OF THIRD PARTY INTELLECTUAL PROPERTY RIGHTS.

These resources are intended for developers skilled in the art designing with Renesas products. You are solely responsible for (1) selecting the appropriate products for your application, (2) designing, validating, and testing your application, and (3) ensuring your application meets applicable standards, and any other safety, security, or other requirements. These resources are subject to change without notice. Renesas grants you permission to use these resources only for development of an application that uses Renesas products. Other reproduction or use of these resources is strictly prohibited. No license is granted to any other Renesas intellectual property or to any third party intellectual property. Renesas disclaims responsibility for, and you will fully indemnify Renesas and its representatives against, any claims, damages, costs, losses, or liabilities arising out of your use of these resources. Renesas' products are provided only subject to Renesas' Terms and Conditions of Sale or other applicable terms agreed to in writing. No use of any Renesas resources expands or otherwise alters any applicable warranties or warranty disclaimers for these products.

(Disclaimer Rev.1.0 Mar 2020)

### Corporate Headquarters

TOYOSU FORESIA, 3-2-24 Toyosu,  
Koto-ku, Tokyo 135-0061, Japan  
[www.renesas.com](http://www.renesas.com)

### Contact Information

For further information on a product, technology, the most up-to-date version of a document, or your nearest sales office, please visit:  
[www.renesas.com/contact/](http://www.renesas.com/contact/)

### Trademarks

Renesas and the Renesas logo are trademarks of Renesas Electronics Corporation. All trademarks and registered trademarks are the property of their respective owners.