

THIS DRAWING IS UNPUBLISHED. RELEASED FOR PUBLICATION
 © COPYRIGHT - TE Connectivity Ltd. ALL RIGHTS RESERVED.

REVISIONS					
P	LTR	DESCRIPTION	DATE	DWN	APVD
	A4	REVISED PER ECR-15-009002	31JAN2019	JH	PKS

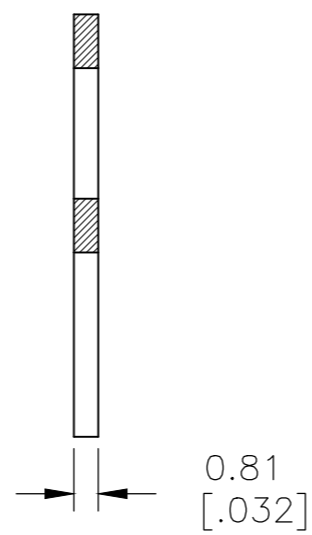

- 1 SPECIFICATION MAGNET WIRE:
#12-#23 AWG, 0.56-2.06 [.022-.081] DIA COPPER.
- 2 SPECIFICATION COMPONENT WIRE:
#23 AWG, 0.56 [.022] DIA SOLID COPPER.
CONSULT TYCO ELECTRONICS FOR OTHER WIRE SIZES.
- 3 POCKET RECOMMENDATION: 1601436.
- 4 TERMINAL APPLICATION TO COMPLY WITH TYCO ELECTRONICS SPECIFICATION 114-13210 FIGURE 3.

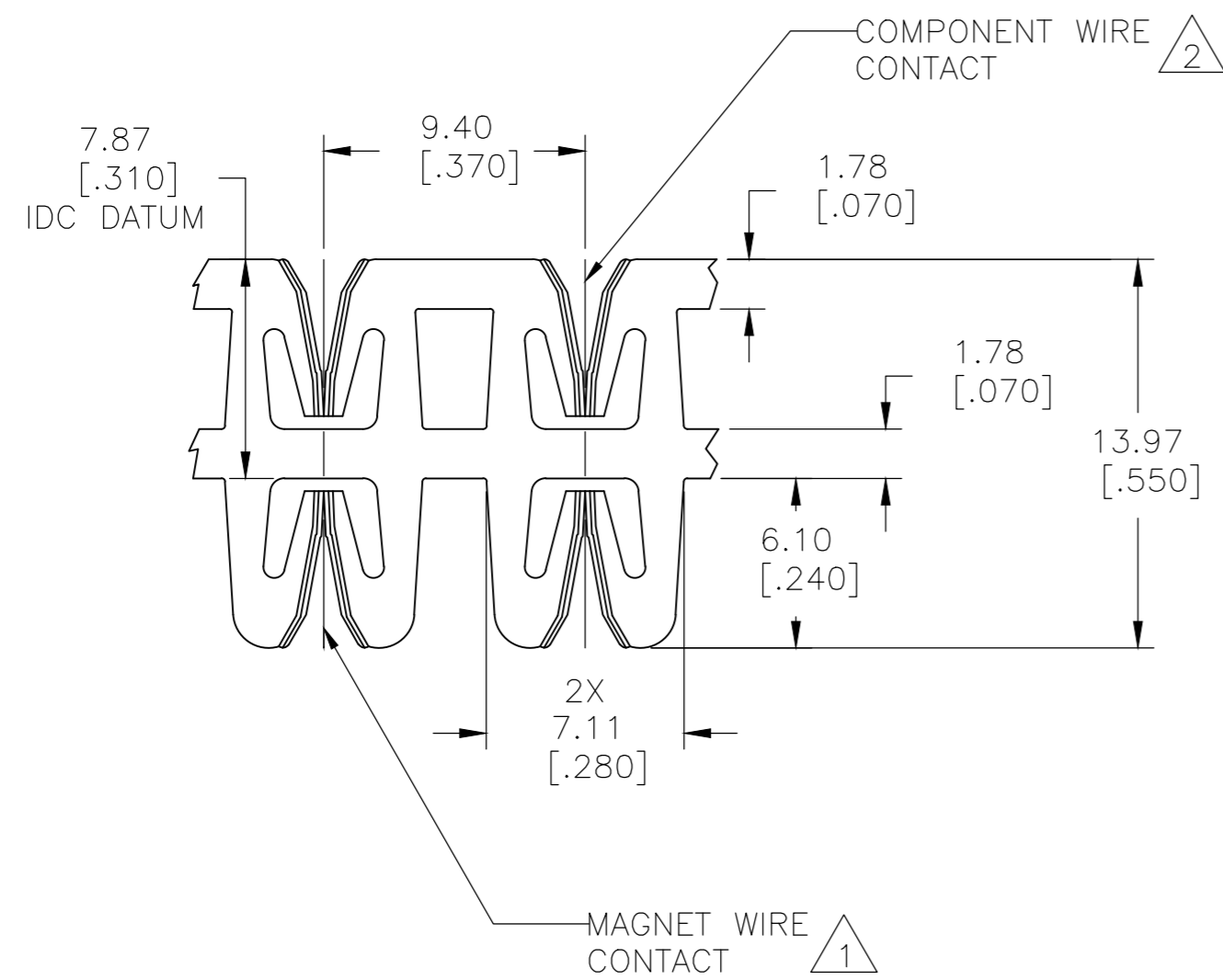
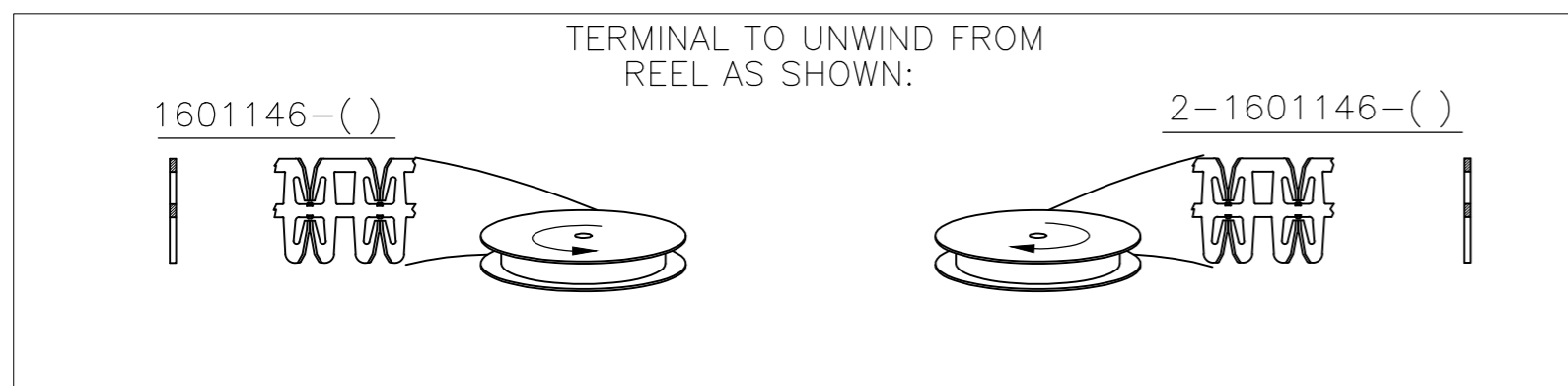
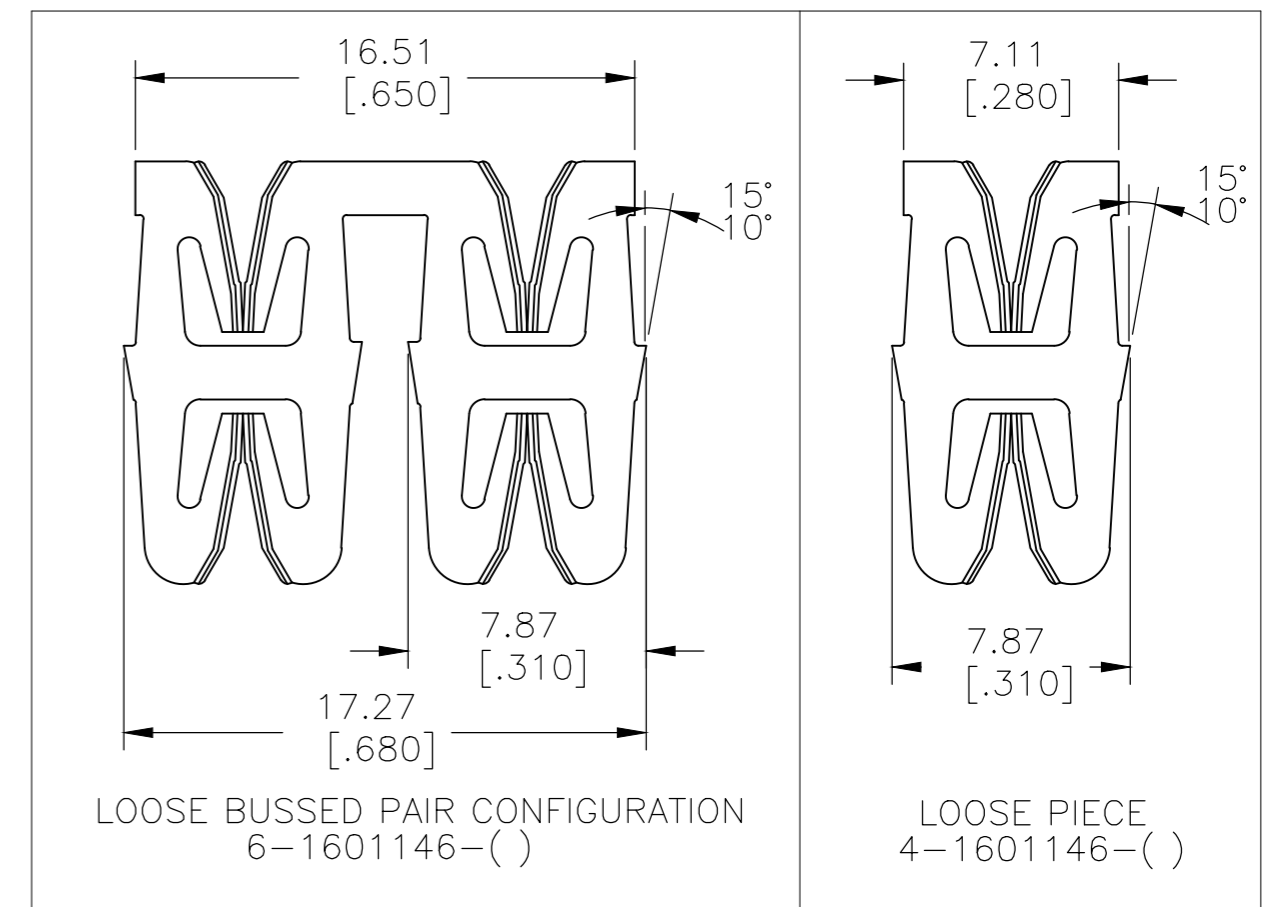

OBSOLETE	2-1601146-1
	1601146-1
	PART NUMBER

THIS DRAWING IS A CONTROLLED DOCUMENT.		DWN MICHAEL S. FEHER 30AUG2005		
DIMENSIONS: mm [INCHES]		CHK GENE JACONO 30AUG2005		
TOLERANCES UNLESS OTHERWISE SPECIFIED:		APVD GENE JACONO 30AUG2005	NAME MEDIUM RANGE WIRE TO WIRE HIGH CARRIER SIAMEZE TERMINAL	
0 PLC ± - 1 PLC ± 0.25[.010] 2 PLC ± 0.13[.005] 3 PLC ± - 4 PLC ± - ANGLES ± 2°		PRODUCT SPEC 108-2239	SIZE A2	
MATERIAL BRASS, SPRING HARD		FINISH UNPLATED	APPLICATION SPEC -	CAGE CODE 00779
		WEIGHT 0.000000	DRAWING NO 1601146	RESTRICTED TO -
		CUSTOMER DRAWING	SCALE 4:1	SHEET 1 of 1
			REV A4	