

RAST 2.5 Power SEMI-AUTOMATIC TERMINATOR MACHINE
For Appli-Mate™ Connectors
Order No. 62300-6000
Operation Manual



- Description
- Operation
- Maintenance

WARNING

NEVER USE THIS FIXTURE WITHOUT THE GUARDING OR OTHER SAFETY DEVICES IN PLACE, GUARD DOORS CLOSED AND GUARD OVERRIDE SWITCHED "OFF".

FIXTURE GUARDING IS DESIGNED TO PREVENT HANDS FROM REMAINING IN THE DANGER AREAS OF THE FIXTURE.

RUNNING THIS FIXTURE WITHOUT GUARDS, UNDER ANY CIRCUMSTANCES, CAN CAUSE SERIOUS INJURY.

NEVER OPERATE, SERVICE OR ADJUST THIS FIXTURE WITHOUT PROPER INSTRUCTION AND WITHOUT FIRST READING AND UNDERSTANDING THE INSTRUCTIONS IN THE OPERATING MANUAL.

NEVER SERVICE THIS FIXTURE WHILE IT IS CONNECTED TO ANY ELECTRICAL POWER SOURCE. DISCONNECT POWER BY SWITCHING OFF THE MAINS ISOLATOR.

WORK SAFELY AT ALL TIMES

**For Service, Contact Your
Local Molex Sales Office**

**Molex Application Tooling Group
2200 Wellington Court
Lisle, Illinois 60532
Tel: 630-969-4550
Fax: 630-505-0049**

Table of Contents

SECTION

1. General Description
2. Start Up / Shut Down Procedures
3. Message Fault Display and Maintenance
4. Touch Screens and Troubleshooting
5. Assembly Drawings, Electrical and Pneumatic Diagrams
6. Connector Series Chart

Section 1

General Description

- 1.1. Description
- 1.2. Technical Specifications
- 1.3. Applicable Products and Wires
- 1.4. Delivery Check
- 1.5. Ce Compliance

1.1 Description

The 62300-6000 APPLI-MATE™ (Rast 2.5 Power) Semi-Automatic Terminator Machine, is designed to terminate the APPLI-MATE™ (Rast 2.5) female connector series (91627, and 91791) onto discrete wire (0.50 mm² or 0.75 mm²). This machine will accommodate circuit size 2 through 12.

1.2 Technical Specifications

Power Specifications:

To function correctly, these fixtures require the following services:

Electrical Service

115/220 VAC 50/60 HZ 1 Phase 2 AMPS

Pneumatic Service

6 BAR (85 psi) Minimum Clean, Dry and Filtered Air Source

Pressure Gauge Settings

Main supply to machine - 6 BAR (85 psi)

1.3 Applicable Products And Wires

Connectors

Appli-Mate™ RAST 2.5 Power connector series 91627 and 91791. See Connector Chart in Section 6.

Wires

Conductor: 0.50mm² or 0.75mm²
Insulation outer diameter: 2.50mm maximum

1.4 Delivery Check

Carefully remove this machine from its shipping container and determine that the following items are included in the package.

Order No.

62300-6000	Semi-Automatic Terminator Machine for APPLI-MATE™ (Rast 2.5 Power)
TM-623006000	Operation Manual

1.5 CE Compliance

Complies with the general health and safety requirements in accordance with:

- Council Directive 98/37/EEC
- Council Directive 89/336/EEC and amended by 92/31/EEC
- Council Directive 73/23/EEC

This machinery has been designed and manufactured in accordance with the following transposed harmonised European standards.

- I.S.EN 12100: parts 1 and 2: 2003, Safety of Machinery - Basic concepts, general principles for design.
- I.S.EN 294: 1994, Safety of Machinery - Safety distances to prevent danger zones reached by the upper limbs.
- I.S.EN 349: 1993, Safety of Machinery - Minimum gaps to avoid crushing of parts of the human body.
- I.S.EN 418: 1993, Safety of Machinery - Emergency stop equipment, functional aspects - Principles for design.
- I.S.EN 60204 part 1: 2006, Safety of Machinery - Electrical equipment of machines - Specification for general requirements.

Section 2

Start-Up / Shut Down Procedures

- 2.1. General Operation
- 2.2 Machine Operation and Process Flow
- 2.3 Operator Set Up And Functions

2.1 General Operation

2.1.1 Preliminary

1. Connect air supply to fixture. Use 6mm nylon air hose in the quick-fitting.
2. Turn on mains power Isolator.
3. Release Emergency-stop push buttons if necessary.

2.1.2 System Start-Up (When above conditions are met)

1. Reset the power by pushing the Reset button.
2. Wait approximately 5 seconds for the air supply to reach operating pressure.
3. Home the sensor motor. See section 4.1 (screen 5).
4. Enter the circuit size. See section 4.1.
5. Press Start button.

2.1.3 Start-Up Following A Fault

1. Identify the fault on the touch screen.
2. Correct fault.
3. Reset the power by pushing the Reset button.
4. Wait approximately 5 seconds for the air supply to reach operating pressure.
5. Home the sensor motor.
6. Press Start button.

2.1.4 Start-Up After An Emergency Stop Or Guard Interrupt

1. Release Emergency Stops or close guard doors.
2. Press Reset button on operator panel.
3. Wait approximately 5 seconds for the air supply to reach operating pressure.
4. Home the sensor motor.
5. Press Start button on operator panel

2.1.5 Start-Up After A Power Failure

1. Release Emergency Stops or close guard doors.
2. Press Reset button on operator panel.
3. Wait approximately 5 seconds for the air supply to reach operating pressure.
4. Home the sensor motor.
5. Enter the Circuit size.
6. Press Start button on operator panel

2.1.6 System Shut Down

1. Press the Emergency Stop button.
2. For extended periods of shutdown (i.e. Holidays), switch off the Mains Isolator.

CAUTION: NEVER OPERATE THIS FIXTURE WITHOUT GUARDS IN PLACE.

2.2 Semi-Automatic Terminator Machine Operation and Process Flow

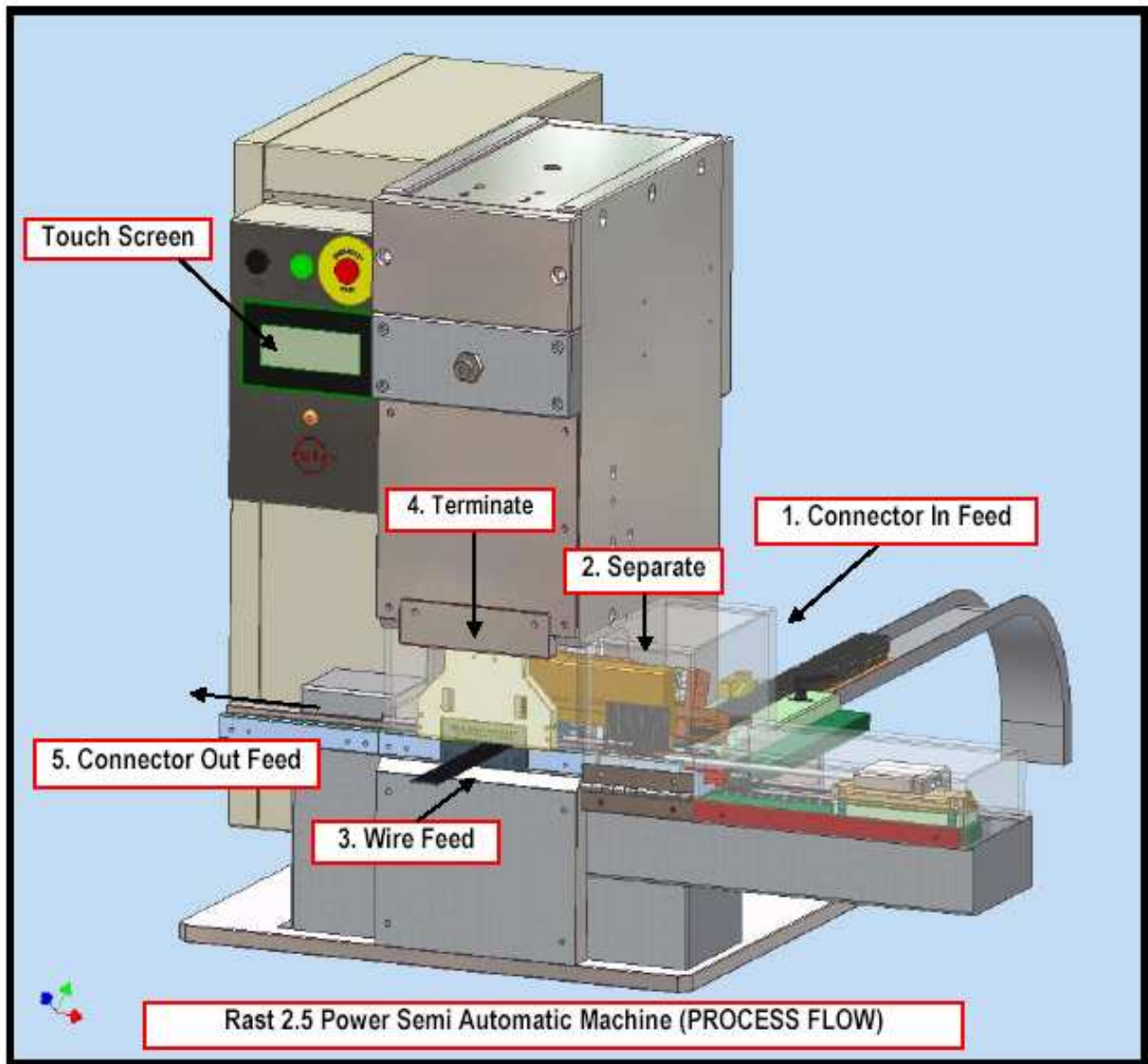

2.2.1 Connector Infeed

The strips of connectors are inserted into the adjustable locator. For operator instruction see *section 2.3. (operator set up and functions)* The gripper then clamps the connectors and transports it into the next part of the process, the cut station. This machine is designed to run one chain of connectors at a time. Connector chains should not be stacked side-by-side.

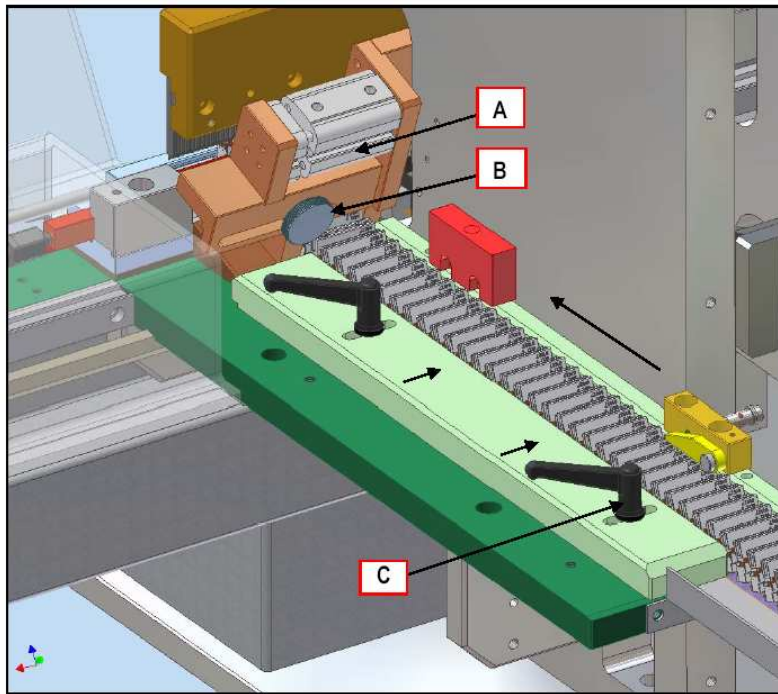

- A Clamping Cylinder
- B Knurled Screw to tighten/release the adjustable gripper jaw
- C Rail Clamp Screw

2.2.2 Connector Separate (Cut Loose)

1. In the automatic mode the connectors are transferred to the cut station by the connector feed cylinder.
2. The cut support track automatically moves in behind the first row of connectors.
3. The cut blade separates the first row of connectors from the chain, so it can be fed to the next station.
(The connector feed cylinder remains forward until after the cut.)
4. Note: Cutting loose happens simultaneously with termination.

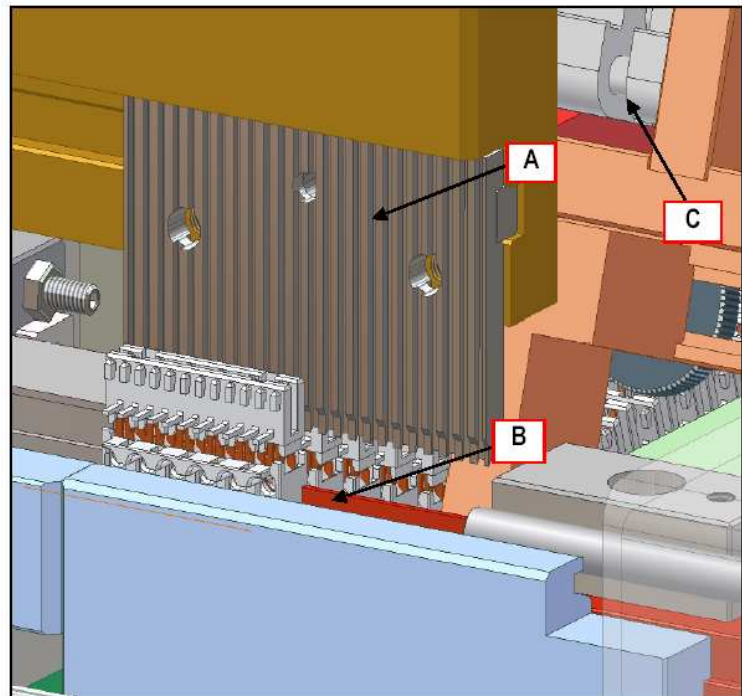

- A Cut Loose Blade
- B Cut Support Track
- C Connector Feed Clamp Cylinder

2.2.3 Connector Transfer

1. After a row of connectors has been separated they are transferred to the termination position.
2. After a connector has been inserted with wires and has been terminated the finished assembly is transferred out of the terminating station while the newly separated connector enters.
3. The connector transfer and the out feed are one motion.

- A Transfer Cylinder
- B Connecting Rod
- C Transfer Rod
- D Out Feed Pawl

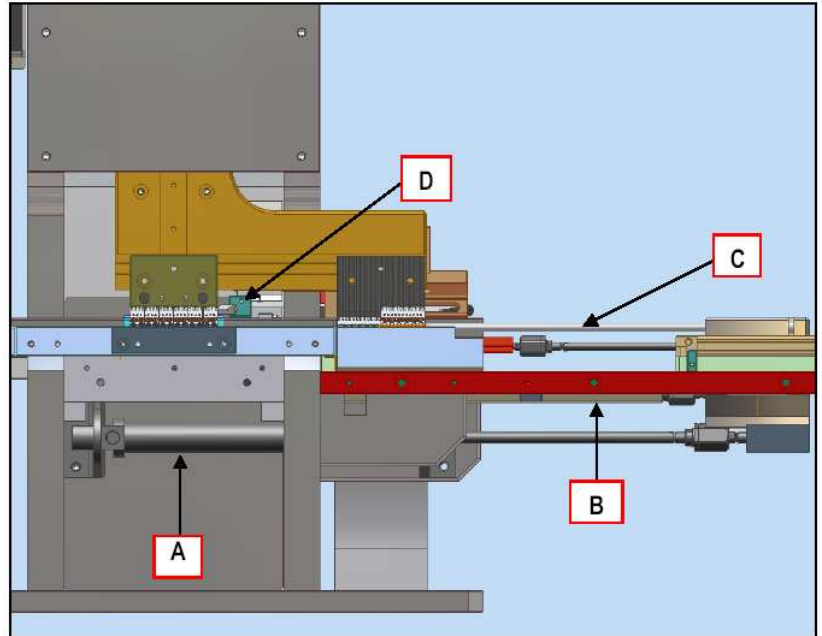

2.2.4 Wire Feed (Mask Tooling)

1. After the connector has been transferred from the cut station to the termination station the operator manually inserts the wires into the connector.
2. This is aided by using a numbered plate (mask tooling) that slides down in front of the connector.
3. This slide centers the connector by engaging spring-loaded comb tooling from below.
4. The operator can then use the mask tooling to guide the wires into the connector. See Section 2.3.4 (*operator set up and functions*)

- A Mask Tooling (numbered plate)
- B Manually inserted wires

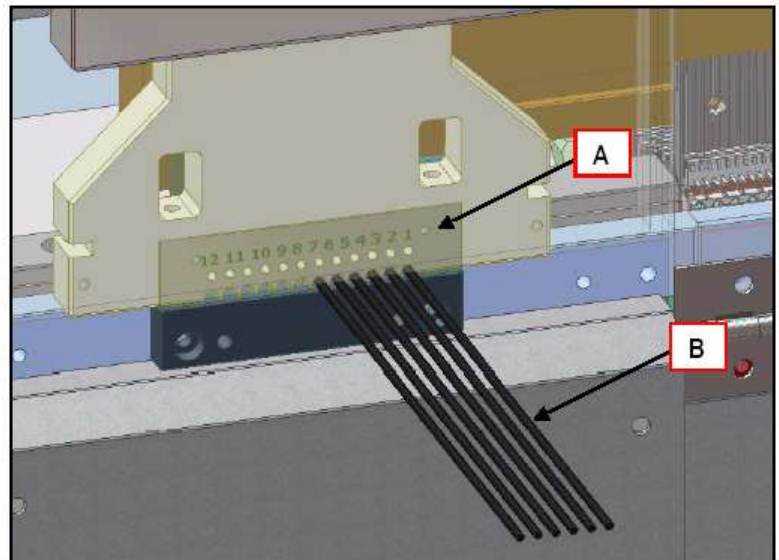

2.2.5 Wire Sensor

1. A Laser Sensor detects that the wires are inserted to the proper depth in the connector.
2. According to the connector circuit size and corresponding program selected by the operator (See Section 2.3.4) the machine detects that the correct amount of wires have been inserted successfully.
3. The operator is prompted when the wire has been successfully inserted. When all wires have been successfully inserted, the machine automatically terminates the connector.

A Laser Sensor to detect wire position in connector

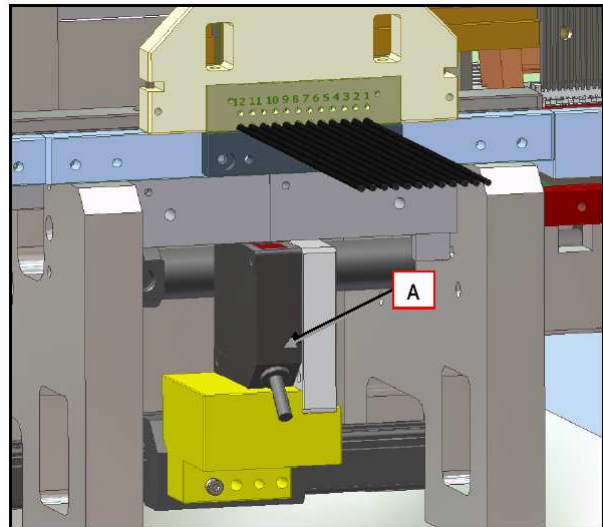

2.2.6 Termination Station

1. The connector is automatically terminated after all the wires have been inserted correctly.
2. The termination tool moves downwards and closes the connector, terminating the inserted wires.
3. At the same time a new row of connectors is being cut free from the chain.
4. The out feed pawl then removes the finished assembly to the end of the track.

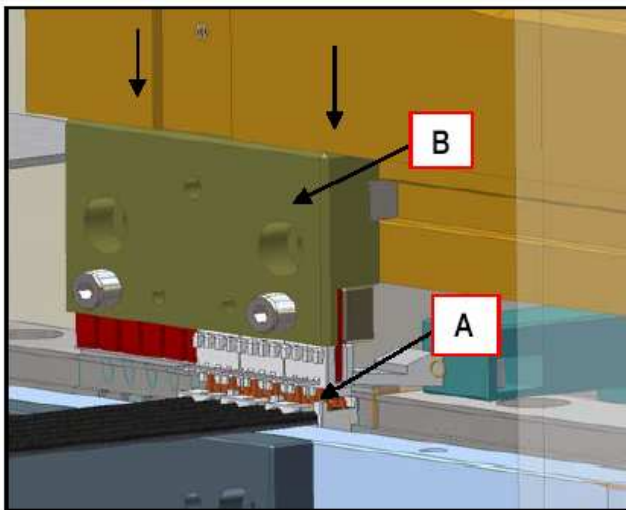

A Open Connector
B Termination Tool

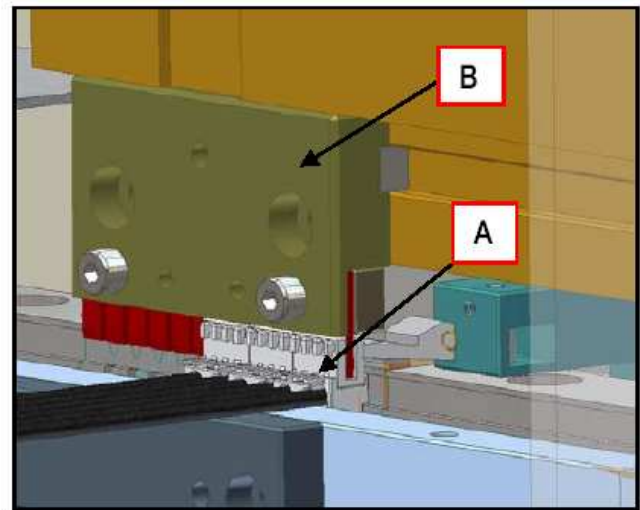

A Closed Connector
B Termination Tool

2.3 Operator Set-Up and Functions

2.3.1 Machine Run

To Power Up

1. Turn on main disconnect switch on electrical cabinet door.
2. Touch screen will reset.
3. Laser sensor motor will automatically home itself or request operator to press home button.

To Set Up (Touch Screen)

1. Press "Manual"
2. Press "Set up"
3. Select circuit size (2 – 12)
4. Select positions of wires to be inserted and choose the language.
5. Press "main" to return to start screen.

To Load Connector

1. Press "Manual "
2. Press " Hsg feed open"
3. Press "Hsg cut support"
4. Feed connectors manually to touch face of cut support blade. See section 2.3.3
5. Press "Hsg feed grip"
6. Press "Main"
7. Press "Load"
8. Terminator Machine will automatically feed connectors to cut position.

To Start Run

1. Press " Start"
2. The first connector will be cut the fed to termination position.
3. Mask tooling will lower
4. Operator must manually insert wires into connector. See section 2.3.4. Touch screen will prompt operator position of each wire.

To Correct An Incorrectly Inserted Wire

1. Cycle can be stopped if wrong wire is put into wrong slot by pressing "REDO"
2. Mask tooling will rise allow removal of wire.
Note: other wires may fall out of the connector and may need to be re-inserted.
3. Press "REDO" to restart cycle.

Note: A wire must be inserted for functions "STOP" or "REDO" to be available on the touch screen.

For detailed explanations of touch screens see SECTION 4.

2.3.2 Material Supply

1. The connectors are supplied in continuous chains and can be connected or disconnected at the trailing end of the chain.
2. A sensor detects when the machine is running low on connectors.
3. The operator then connects the upper housing of the chain in the machine into the lower housing of the new chain. The connector splicing tool should be used to ensure the proper pre-load height.

The operator **MUST** remove the first part of the connector at the beginning of the strip of connectors to be fed into the machine. The strips must begin with a complete connector.

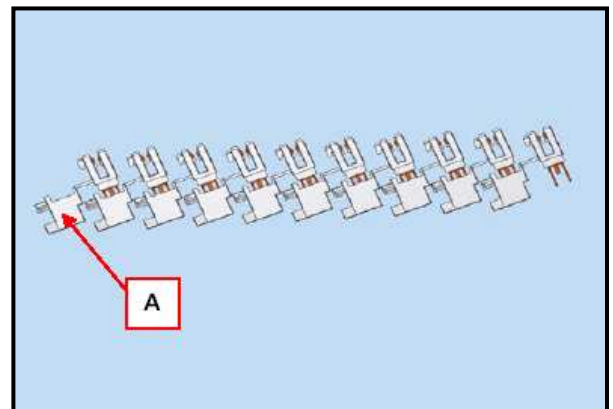

A Removed when loading an empty machine

2.3.3 Setting Up Connector Feed

1. When circuit size is changed the connector feed must be set up.
2. Adjust the guide rail to suit the width of the connectors. This can be set from 2-12 positions.

The rail can be moved by opening the clamp screws and simply sliding the rail lightly against the connector chain as shown. The connectors must be able to slide easily. Retighten the clamp screws.

3. Loosen the knurled screw at the clamping cylinder and slide the gripper jaw as far as possible to the right.
4. Insert a strip of connectors into the machine until they bottom out against the cut support track.
5. Slide the gripper jaw to within approximately 2mm of the connectors and tighten the knurled screw.
6. Select the circuit size with wire quantity and position on the touch screen and start the machine. (See Section 2.3.5)

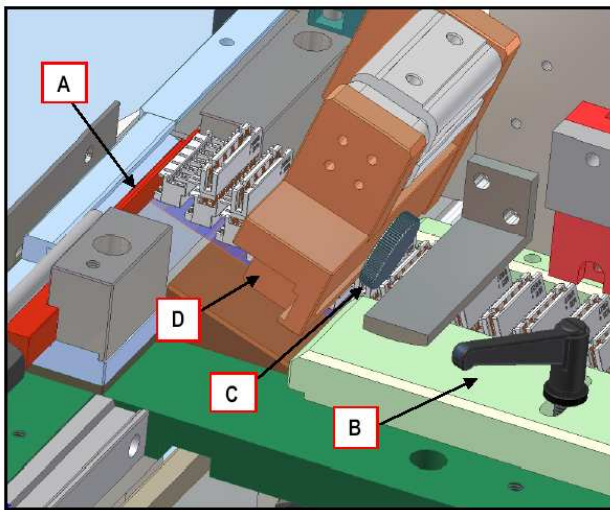

- A Cut Support Track
- B Guide Rail
- C Knurled Screw
- D Gripper Jaw

2.3.4 Wire Feed

1. The Operator must manually insert each connector circuit size with corresponding number of wires.
2. As explained in Section 2.2.5 the operator uses a numbered guide as an aid to insert the wires into the connector. The touch screen prompts the operator to the number slot on the guide to place each wire.
3. After the operator has correctly inserted the wire at the correct position an audio tone will sound, an LED will illuminate, and the operator can

move to the next position (prompted on the touch screen).

4. The mask tooling has spring loaded inserts which will keep the wires held in position until the connector has been terminated. After the wire is inserted, do not attempt to pull the wire out as the clamp grip may damage the wire. If an insertion error occurs, it is best to use the REDO function.

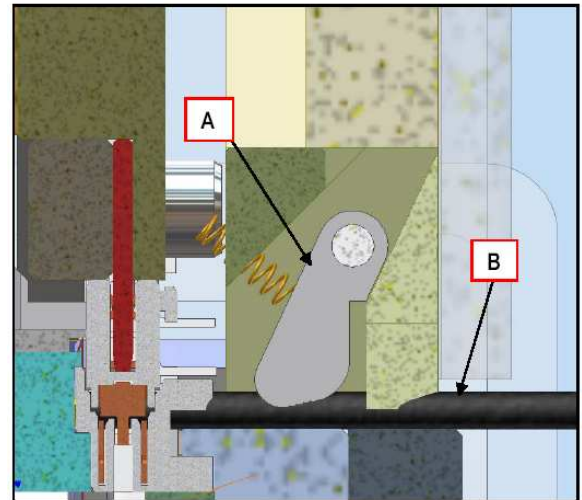

- A Spring Loaded Wire Clamp
- B Fully inserted Wire

2.3.5 Termination Shut Height Adjustment

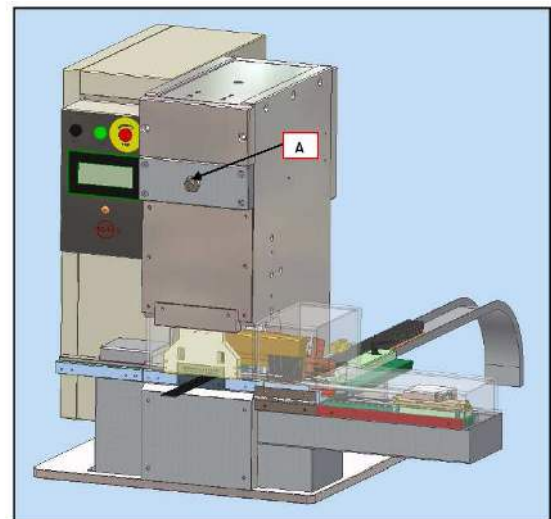

- A Shut Height Fine Adjustment Screw
1. The termination shut height may be easily adjusted from the front of the machine.
 2. Use a 24mm open-end wrench and an 8mm hex key to finely adjust the shut height.

3. The adjustment screw is situated at the front of machine as shown.
4. For termination shut height specifications see document AS-91627-001, section 8.0.

2.3.6 Program Selection (Circuit Size)

1. When circuit size (or number of wires loaded) changes, the program must be changed on the touch screen.
2. The following procedure must be followed when setting up for a new program and circuit size as well as setting up new connector feed. See section 2.3.2.
3. On the touch screen:
 - a. From Ready to Run. Press "Manual"
 - b. From Manual. Press "Set Up"
 - c. From Set Up. "Enter circuit size." Keypad will appear. Select desired circuit size (2-12 circuit). Size will be displayed on circuit size line.
 - d. From Set Up. Press "Next"
 - e. Select Wire Positions. Press the number and Y and N will toggle in the box above the

number. Y= Wire Present, N= No Wire.

Ensure that unused circuit positions have N.

- f. From Select Wire Positions. Press "Main" to return to Ready to Run.
- g. Press "Start" to run automatically. Press "Load" to feed a housing into the feed track.

2.3.7 Machine Errors / Faults

The Operator is responsible for ensuring that machine errors / faults are corrected immediately. If the operator is unable to locate or resolve the fault, they should seek assistance from the line Technician.

See Section 4 for a full listing of faults.

2.3.8 Finished Product

The operator will ensure that the finished products are removed from the end of the machine.

Section 3

Message Fault Display and Maintenance

3.1 Fault Displays

3.2 Maintenance

3.3 Perishable Tooling

3.4 Spare Parts

3.1 Fault Displays

3.1.1 Name and Functions

Name	Location	Function
Emergency Stop (Red Mushroom knob on yellow background)	LH side of machine. (Control Box)	To stop fixture immediately as well as isolating the mains power and air from the fixture.
Power On Lamp (Green Lamp)	Centre of machine. (Control Box).	To Indicate that the machine is ready to run.
Reset Button (Blue Switch)	LH side of machine. (Control Box)	To connect mains power and air to the machine.

3.1.2 Description Of Indicators

Name	Indicator	Description
LED (Green)	Solid Green	Wire inserted
Speaker	Audible “beep”	Wire inserted

3.2 Maintenance

3.2.1 Cleaning

The RAST 2.5 Power Semi-Automatic Terminator Machine should be cleaned at least once a day with a soft brush to remove dust and debris.

CAUTION: Using compressed air to clean the Terminator is not recommended as debris could become jammed in the tooling and/or come flying out at the operator

3.2.2 Lubrication

The press requires regular lubrication on a monthly basis. Place a small amount of lubricant with Teflon, such as Permatex “Superlube”, on the sliding surfaces.

An example of a maintenance chart is shown below. Copy and use this chart to track the maintenance of your Terminator or use this as a template to create you own schedule or use your company’s standard chart, if applicable.

3.2.3 Preventive Maintenance Chart

Time	Maintenance
Daily	Clean all tooling in the following areas
	<ul style="list-style-type: none"> ✓ Slides ✓ Cylinders
Weekly	✓ Check out tooling for signs for of wear.
	✓ Check cutting and termination tools for signs of wear.
	✓ Check condition of slides.
	✓ Check that the air regulator is set to 6 Bar (85 psi).
	✓ Ensure all shock absorbers and stops are tight.
Monthly	✓ Wipe down all tooling in the following areas: slides, cylinders, and carriage rails.
	✓ Carry out Weekly PM.
	✓ Check slide for excessive play (tighten as necessary).
	✓ Check condition of all shock absorbers and stops.
	✓ Check out functionality of all sensors.
	✓ Check for air leaks, loose fittings, damaged airlines, and gauges.
6 Months	✓ Check General condition of all tooling.
	✓ Carry out Monthly Preventative Maintenance.

3.3 Perishable Parts

Customers are responsible for maintaining the The RAST 2.5 Power Semi-Automatic Terminator Machine. Perishable parts are those parts that come in contact with the product and will wear out over time. Molex recommends that all customers keep at least one set of the perishable tool kits in stock at all times. This will reduce the amount of production down time. These parts are identified in the Parts List below.

Perishable Tooling List			
Part No.	Description	Circuit	Quantity
62300-6001	Housing Cut Blade		1
62300-6002	Termination Tool		1
62300-6003	Connector Support Blade	12 Circuits	▪ 1
62300-6004	Out Feed Pawl (side latches)		1
62300-6083	Connector Support Blade Set	2-12 Circuits	▪ 1
▪ Other circuit size blades available (see cut and termination assembly parts list)			

3.4 Spare Parts

Customers are responsible for maintaining the The RAST 2.5 Power Semi-Automatic Terminator Machine. Spare parts are available. Moving and functioning parts can be damaged or wear out over time and will require replacement. See assembly drawings and parts lists in Section 5 for additional detail.

Spare Parts List (Sub-Assemblies)

Main Frame Assembly				
Item	Part No.	Description	Manufacturer	Quantity
1	DSNU 20-150-PPV-A-S10	Cylinder		1
2	2062-FK-M8	Floating Joint		1
3	HBN-20/25 x 2	Foot Mounting		1 Pair
4	SHHPS8-3	Stainless Hinge	Misumi	1
5	M16 Eyebolt	Eyebolt	Ganter/Griff	1
Termination Slide Drive Assembly				
Item	Part No.	Description	Manufacturer	Quantity
1	ADVU-80-30-A-P-A	Compact Cylinder	Festo	1
2	SUA-80	Cylinder Clevis	Festo	1
3	AMF 15 21-25	Oillite Bushing	Oillite	2
4	AMC12 15-16	Oillite Bushing	Oillite	2
5	AMC 16 20-12	Oillite Bushing	Oillite	4
Housing Infeed Assembly				
Item	Part No.	Description	Manufacturer	Quantity
1	DZF-12-70-A-P-A	Cylinder	Festo	1
2	2061 FK-M6	Floating Joint	Festo	1
3	SRS 15M UU +270L	Linear Slide	THK	1
4	GN 300.1-45-m6-32-bki	Handle	ITEM	2
Housing Cut Assembly				
Item	Part No.	Description	Manufacturer	Quantity
1	2SRS15WM UU +190L H	Linear Slide	THK	1
Housing Gripper Assembly				
Item	Part No.	Description	Manufacturer	Quantity
1	ADVUL-16-5-P-A	Compact Cylinder	Festo	1
2	DFM-16-20-P-A-GF	Cylinder	Festo	1
3	GN-421-M6-25-NI	Handle	Ganter/Griff	1
4	DIN 653 M6-16	Flat Knurled Thumb Screw	Ganter/Griff	1
Out Feed Pawl Assembly				
Item	Part No.	Description	Manufacturer	Quantity
1	LBRFNF6-254-10-PC-QC	Linear Rod	Misumi	1
2	2061 FK-M6	Floating Joint	Festo	2
3	Entex # 3302	Compression Spring	Entex	2
4	Entex # 3166	Compression Spring	Entex	2
5	SRS 15M UU +270L	Linear Slide	THK	1
Termination Assembly				
Item	Part No.	Description	Manufacturer	Quantity
1	DMM-20-20-P-A	Cylinder	Festo	1
2	SRS 9WM UU +50L	Linear Slide	THK	1
3	Entex # 3094	Compression Spring	Entex	20
4	Entex # 3100	Compression Spring	Entex	20

Section 4

Touch Screens and Troubleshooting

Touch Screens

Screen 1 Start Up Screen

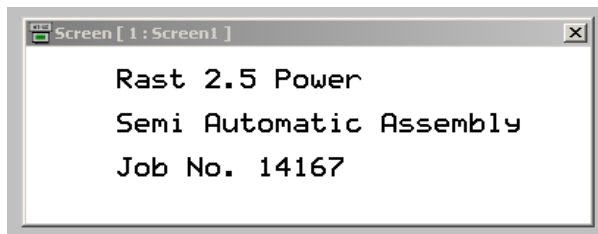

This screen appears after the machine has been powered up. It is only an information screen.

Screen 2 Ready to Run Screen

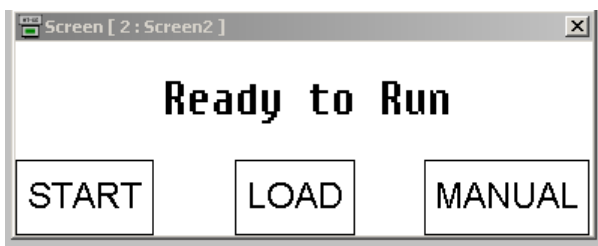

This screen is displayed when the machine is stopped and there are no fault conditions. It has 3 buttons located on the bottom.

START: This button starts the machine.

LOAD: When there is no housing in the feed track, press this button to automatically move a part into the feed track.

MANUAL: Selects manual mode and changes the screen to the Manual #1 [Screen 30].

Screen 3 Emergency Stop Screen

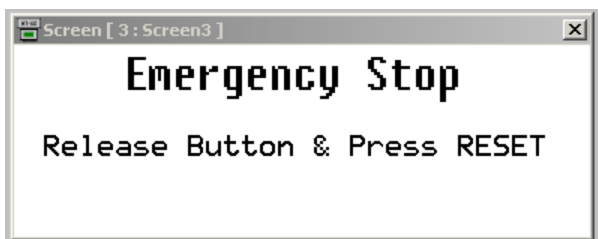

This screen is displayed when the Emergency Stop button has pressed. It also appears after power up and after the Safety Guard Open screen, when the door has been closed. Release the Emergency

Stop button and press the blue reset button on the main Panel.

Note: The wire sensor stepper motor must be re-homed after E-stop.

Screen 4 Safety Guard Open Screen



This screen is displayed when the safety guard is open. Close the guard and press the blue reset button on the main panel.

Screen 5 Sensor must be Homed Screen

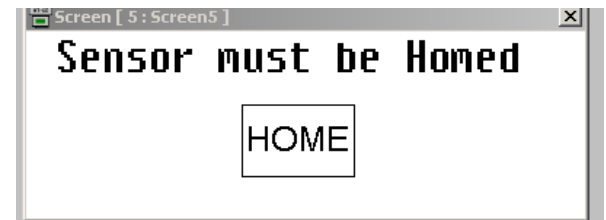

This is displayed after the machine has been reset. The stepper motor that drives the wire sensor must be homed after a power down or Emergency Stop to ensure it is in the correct position to detect the wires. Press the **HOME** button and it will home automatically. When the stepper reaches the home position, the Ready to Run screen will be displayed.

Screen 6 Running Screen



This screen is displayed when the machine is running in automatic mode.

Parts Made: Displays how many parts have been made in the current batch.

Insert Wire into Position: Displays the position where the current wire is to be inserted.

STOP: This button stops the automatic mode. The operator must finish inserting all wires into the connector and terminate the connector before the end of cycle is reached.

REDO: This button allows the operator to correct an error on the existing connector. The mask tooling will go up, the wire(s) can be removed and the wire sensor motor will go to home position. Screen 9 will be displayed when this button is pressed.

Screen 7
Waiting to Stop Screen



This screen is displayed after the stop button has been pressed and before the current cycle has been completed.

Parts Made: Displays how many parts have been made in the current batch.

Insert Wire into Position: Displays the position where the current wire is to be inserted.

REDO: This button allows the operator to correct an error on the existing housing. The mask tooling will go up, the wires can be removed and the wire sensor motor will go to home position. Screen 9 will be displayed when this button is pressed.

Screen 8
Sensor is Homing Screen

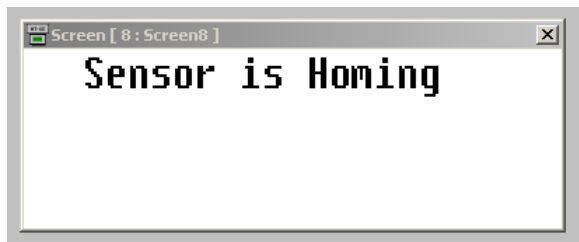

This screen is displayed after the Home Sensor Button has been pressed on Screen 5. When the sensor reaches the home position the Ready to Run Screen will be displayed.

Screen 9
Redo Screen

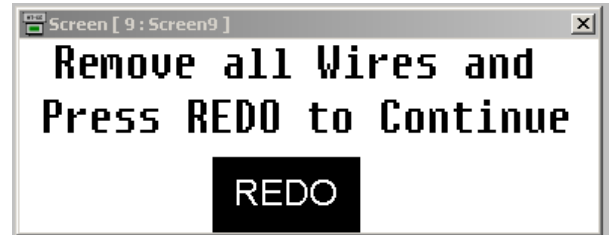

This screen appears after REDO has been pressed on either Screen 6 or 7. When all the wires have been removed, press REDO to return to Screen 6 or 7.

Screen 10
Conveyor Low Level Fault Screen

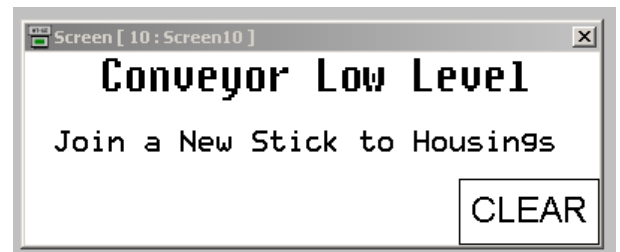

This screen is displayed when the connector conveyor level is low. Join another chain to the existing chain and press the CLEAR button to continue.

Screen 11
Housing Cut Support not Out Fault Screen



This screen is displayed when the Housing Cut Support Cylinder (See Section 2.2.2) fails to activate sensor B0.05. Check to see if the tooling jammed or if something is stopping the cylinder from completing its stroke. Clear the fault and press CLEAR button.

Air may have to be removed from the machine to clear the fault either by pressing Emergency Stop, opening the guard door or disconnecting the air supply. If any of these are done their respective faults (“Emergency Stop”, “Safety Guard Open”, or “Air Pressure Low”) will take precedence on the display.

Screen 12
Housing Cut Support Not In Fault Screen.



This screen is displayed when the Housing Cut Support Cylinder (See Section 2.2.2) fails to activate sensor B0.06. Check to see if the tooling jammed or if something is stopping the cylinder from completing its stroke. Clear the fault and press **CLEAR** button.

Air may have to be removed from the machine to clear the fault either by pressing Emergency Stop, opening the guard door or disconnecting the air supply. If any of these are done their respective faults (“Emergency Stop”, “Safety Guard Open”, or “Air Pressure Low”) will take precedence on the display.

Screen 13
Housing Feed not Back Fault Screen



This screen is displayed when the Housing Feed Cylinder (See Section 2.2.2) fails to activate sensor B0.10. Check to see if the tooling jammed or if something is stopping the cylinder from completing its stroke. Clear the fault and press **CLEAR** button.

Air may have to be removed from the machine to clear the fault either by pressing Emergency Stop, opening the guard door or disconnecting the air supply. If any of these are done their respective faults (“Emergency Stop”, “Safety Guard Open”, or “Air Pressure Low”) will take precedence on the display.

Screen 14
Housing Feed not Forward Fault Screen

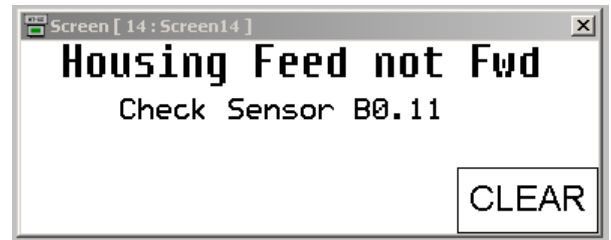

This screen is displayed when the Housing Feed Cylinder (See Section 2.2.2) fails to activate sensor B0.11. Check to see if the tooling jammed or if something is stopping the cylinder from completing its stroke. Clear the fault and press **CLEAR** button.

Air may have to be removed from the machine to clear the fault either by pressing Emergency Stop, opening the guard door or disconnecting the air supply. If any of these are done their respective faults (“Emergency Stop”, “Safety Guard Open”, or “Air Pressure Low”) will take precedence on the display.

Screen 15
Housing Feed Gripper not Closed Fault Screen



This screen is displayed when the Housing Feed Gripper Cylinder (See Section 2.2.1) fails to activate sensor B0.09. Check to see if the tooling jammed or if something is stopping the cylinder from completing its stroke. Clear the fault and press **CLEAR** button.

Air may have to be removed from the machine to clear the fault either by pressing Emergency Stop,

opening the guard door or disconnecting the air supply. If any of these are done their respective faults (“Emergency Stop”, “Safety Guard Open”, or “Air Pressure Low”) will take precedence on the display.

Screen 16
Housing Feed Gripper Cylinder not Open Fault Screen



This screen is displayed when the Housing Feed Gripper Cylinder(See Section 2.2.1) fails to deactivate sensor B0.09. Check to see if the tooling jammed or if something is stopping the cylinder from completing its stroke. Clear the fault and press **CLEAR** button.

Air may have to be removed from the machine to clear the fault either by pressing Emergency Stop, opening the guard door or disconnecting the air supply. If any of these are done their respective faults (“Emergency Stop”, “Safety Guard Open”, or “Air Pressure Low”) will take precedence on the display.

Screen 17
Housing Stick Feed not Back Fault Screen



This screen is displayed when the Housing Stick Feed Cylinder fails to activate sensor B0.07. Check to see if the tooling jammed or if something is stopping the cylinder from completing its stroke. Clear the fault and press **CLEAR** button.

Air may have to be removed from the machine to clear the fault either by pressing Emergency Stop,

opening the guard door or disconnecting the air supply. If any of these are done their respective faults (“Emergency Stop”, “Safety Guard Open”, or “Air Pressure Low”) will take precedence on the display.

Screen 18
Housing Stick Feed not Forward Fault Screen



This screen is displayed when the Housing Stick Feed Cylinder fails to activate sensor B0.08. Check to see if the tooling jammed or if something is stopping the cylinder from completing its stroke. Clear the fault and press **CLEAR** button.

Air may have to be removed from the machine to clear the fault either by pressing Emergency Stop, opening the guard door or disconnecting the air supply. If any of these are done their respective faults (“Emergency Stop”, “Safety Guard Open”, or “Air Pressure Low”) will take precedence on the display.

Screen 19
Mask Tooling not Up Fault Screen



This screen is displayed when the Mask Tooling Cylinder (See Section 2.2.4) fails to activate sensor B1.00. Check to see if the tooling jammed or if something is stopping the cylinder from completing its stroke. Clear the fault and press **CLEAR** button.

Air may have to be removed from the machine to clear the fault either by pressing Emergency Stop, opening the guard door or disconnecting the air supply. If any of these are done their respective

faults (“Emergency Stop”, “Safety Guard Open”, or “Air Pressure Low”) will take precedence on the display.

Screen 20
Mask Tooling not Down Fault Screen



This screen is displayed when the Mask Tooling Cylinder (See Section 2.2.4) fails to activate sensor B1.01. Check to see if the tooling jammed or if something is stopping the cylinder from completing its stroke. Clear the fault and press **CLEAR** button.

Air may have to be removed from the machine to clear the fault either by pressing Emergency Stop, opening the guard door or disconnecting the air supply. If any of these are done their respective faults (“Emergency Stop”, “Safety Guard Open”, or “Air Pressure Low”) will take precedence on the display.

Screen 21
Termination Tooling not Up Fault Screen



This screen is displayed when the Termination Tooling Cylinder fails to activate sensor B1.02, (See Section 2.2.6). Check to see if the tooling jammed or if something is stopping the cylinder from completing its stroke. Clear the fault and press **CLEAR** button.

Air may have to be removed from the machine to clear the fault either by pressing Emergency Stop, opening the guard door or disconnecting the air supply. If any of these are done their respective faults (“Emergency Stop”, “Safety Guard Open”, or

“Air Pressure Low”) will take precedence on the display.

Screen 22
Termination Tooling not Down Fault Screen



This screen is displayed when the Termination Tooling Cylinder fails to activate sensor B1.03 (See Section 2.2.6).. Check to see if the tooling jammed or if something is stopping the cylinder from completing its stroke. Clear the fault and press **CLEAR** button.

Air may have to be removed from the machine to clear the fault either by pressing Emergency Stop, opening the guard door or disconnecting the air supply. If any of these are done their respective faults (“Emergency Stop”, “Safety Guard Open”, or “Air Pressure Low”) will take precedence on the display.

Screen 23
Air Pressure Low Fault Screen

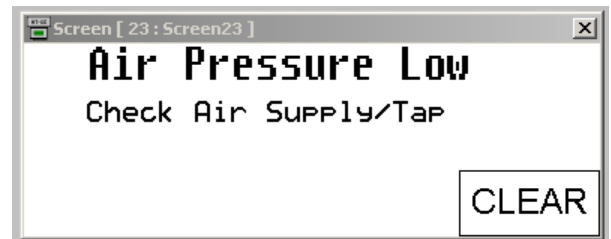

This screen is displayed when the Air Pressure coming to the Machine is Low. Air pressure less than approx. 4 bar / 60 psi. Check the following:

1. Factory Air Pressure is OK.
2. Air is connected to the machine.
3. Air Isolating Valve is turned on.
4. Air Pressure is set to 6.0 bar (85 psi)
5. Air Safety valve is on.
6. Air Leaks air compressor operation.

Screen 30
Manual Screen #1

This screen is displayed when Manual has been selected from the Ready to Run Screen or PREV has been selected from the Manual #2 Screen.

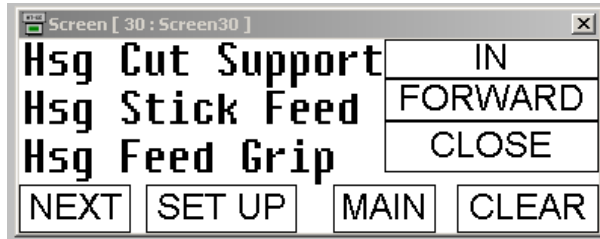

Hsg Cut Support Button: This button allows manual operation of the Housing Cut Support Cylinder. Pressing the button once will extend the cylinder (out); pressing it again will retract the cylinder (in). The text on the button will change between **IN** and **OUT** as the button is pressed.

Hsg Stick Feed Button: This button allows manual operation of the Housing Stick Feed. Pressing the button once will allow the feed to move forward; pressing it again will move the feed to the back position. The text on the button will change between **FORWARD** and **BACK** as the button is pressed. The feed can only move forward if the Housing Cut Support is out and can only move back if the Housing Feed Gripper is open.

Hsg Feed Grip Button: This button allows manual operation of the Housing Feed Gripper Cylinder. Pressing the button once will allow the cylinder to move open, pressing it again will return the cylinder to the closed position. The text on the button will change between **OPEN** and **CLOSE** as the button is pressed.

NEXT: Changes the screen to the Manual #2 Screen

SET UP: Selects Set Up mode and changes the screen to the Set Up #1 [Screen 40].

MAIN: Select Automatic mode and changes the screen to Ready to Run [Screen 2].

CLEAR: Clears any faults.

Screen 31
Manual Screen #2

This screen is displayed when the NEXT button is pressed on Manual Screen #1.

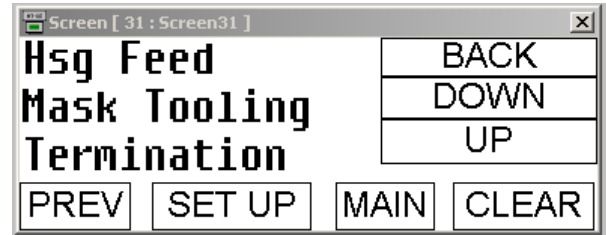

Hsg Feed Button: This button allows manual operation of the Housing Feed. Pressing the button once will allow the feed to move forward; pressing it again will move the feed to the back position. The text on the button will change between **FORWARD** and **BACK** as the button is pressed. (NOTE: Do not move the Housing Feed forward while Termination is down, otherwise a feed jam will result).

Mask Tooling Button: This button allows manual operation of the Mask Tooling Cylinder. Pressing the button once will allow the cylinder to move up, pressing it again will return the cylinder to the down position. The text on the button will change between **UP** and **DOWN** as the button is pressed.

Termination Button: This button allows manual operation of the Termination Cylinder. Pressing the button once will allow the cylinder to move down, pressing it again will return the cylinder to the up position. The text on the button will change between **DOWN** and **UP** as the button is pressed. The cylinder can move **Down** only when the Housing Feed is back.

PREV: Changes the screen to Manual Screen #1.

SET UP: Selects Set Up mode and changes the screen to the Set Up #1 [Screen 40].

MAIN: Select Automatic mode and changes the screen to Ready to Run [Screen 2].

CLEAR: Clears any faults.

Screen 40
Set Up #1 Screen

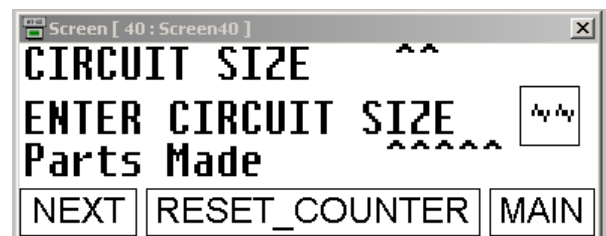

This screen is displayed when the SET UP button is pressed on the Manual Screens or PREV has been selected from the Set Up #2 screen.

CIRCUIT SIZE: This displays the current circuit size of the connectors being processed.

ENTER CIRCUIT SIZE: This button allows the circuit size of the connector to be entered. When the button is pressed a pop-up screen [Screen 65001] will appear. When the ENTER button on the pop-up Screen is pressed, the circuit size will be displayed on the button. Only values between 2 and 12 will be accepted by the display.

Parts Made: Displays how many assemblies have been made in the current batch.

NEXT: Changes the screen to the Set Up #2 Screen.

RESET_COUNTER Button: Resets the value of Parts Made to zero.

MAIN: Select Automatic mode and changes the screen to Ready to Run [Screen 2].

**Screen 65001
Pop Up Screen**

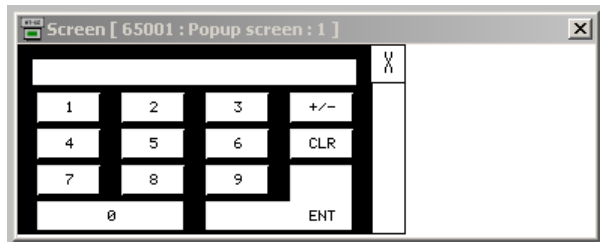

This screen appears when the Enter circuit Size Button has been pressed on Screen 40. Enter the desired circuit size on the “calculator” screen and press ENT. Only values between 2 and 12 will be accepted.

**Screen 41
Set Up Screen #2**

This screen is displayed when the NEXT button is pressed on the Set Up #1 Screen.

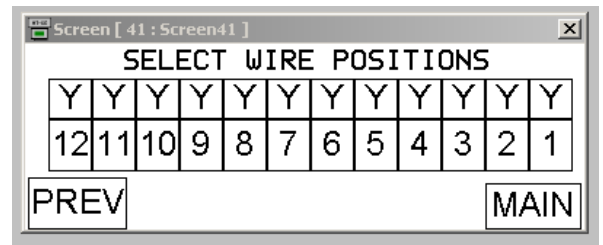

SELECT WIRE POSITIONS: This selects connector positions where wires are to be inserted. Pressing the number of the wire position will either select or deselect the presence of a wire in that position. The current status of that position is displayed above the number (Y = wire present, N = no wire). NOTE: For circuit sizes below 12, make sure positions past the circuit size are selected N.

PREV: Changes the screen to Set Up Screen #1 (Screen 40).

MAIN: Changes the screen to Ready to Run Screen (Screen 2).

**Screen 43
Set Up Screen #4**

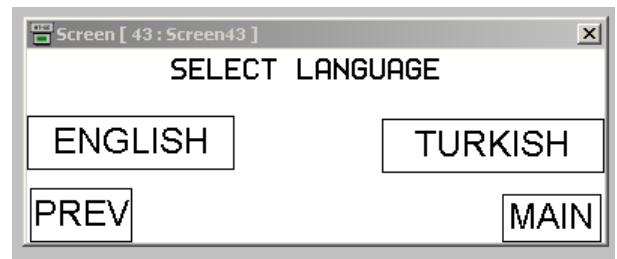

This screen is displayed when the NEXT button is pressed on the Set Up #3 Screen.

SELECT LANGUAGE. This allows language selection for the touch screen messages.

When the screens are displayed in English pressing TURKISH will automatically redisplay the screen in Turkish. All the Turkish screens have the exact same layout and functions as the English screens.

When the screens are displayed in Turkish pressing ENGLISH will automatically redisplay the screen in English.

Section 5

Assembly Drawings, Electrical and Pneumatic Diagrams

- 5.1 Assembly Drawings
- 5.2 Electrical Drawings
- 5.3 Pneumatic Drawings

5.1 Main Assembly

Main Assembly 62300-6000			
Item	Order No.	Description	Qty.
1	62300-6005	Machine Guard Frame Assembly	1
2	62300-6006	Frame Assembly	1
3	62300-6007	Toggle Joint Assembly	1
4	62300-6008	Connector Infeed Assembly	1
5	62300-6009	Cut Loose And Termination Slide Assembly	1
6	62300-6010	Connector In-Feed Cylinder Assembly	1
7	62300-6011	Laser Sensor Assembly	1
8	62300-6012	Main Track Assembly	1
9	62300-6013	Cable Mask Tooling Assembly	1
10	62300-6067	Out-Feed Pawl Assembly	1
11	62300-6072	IOP Box Assembly	1

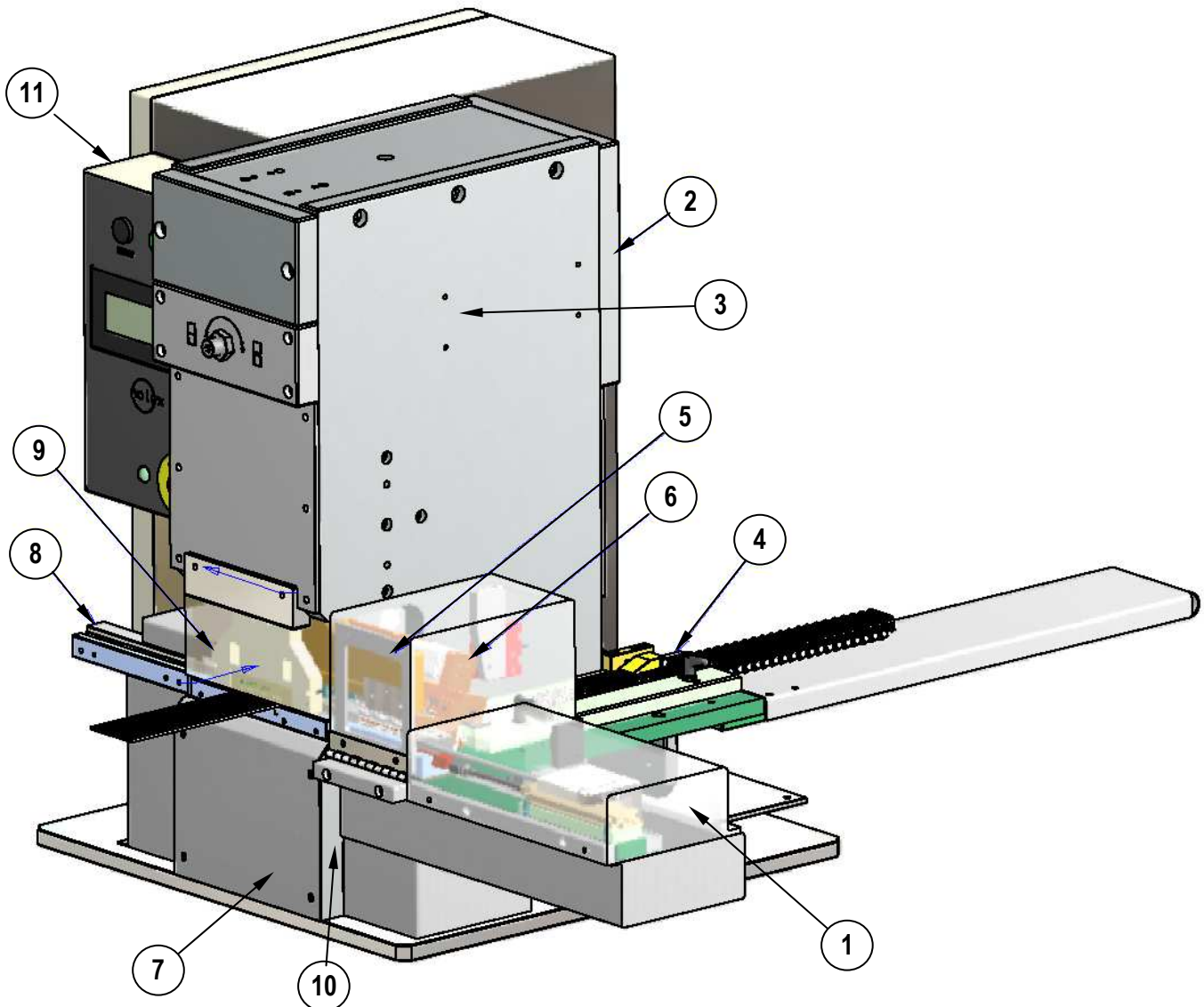

Machine Guard Assembly

Machine Guard Assembly 62300-6005			
Item	Order No.	Description	Qty.
1	62300-6014	Mask Tooling Guard	1
2	62300-6015	Mask Guard Mtg. Plate	1
3	62300-6016	Cut Station Guard	1
4	62300-6017	Out-Feed Guard	1
5	62300-6018	Guard Mtg. Plate	1
6	62300-6019	Piano Hinge	2
7	62300-6217	Guard	1
8	62300-6218	PolyCarb Guard	1
9	62300-6219	Guard	1
10	62300-6220	Guard	1

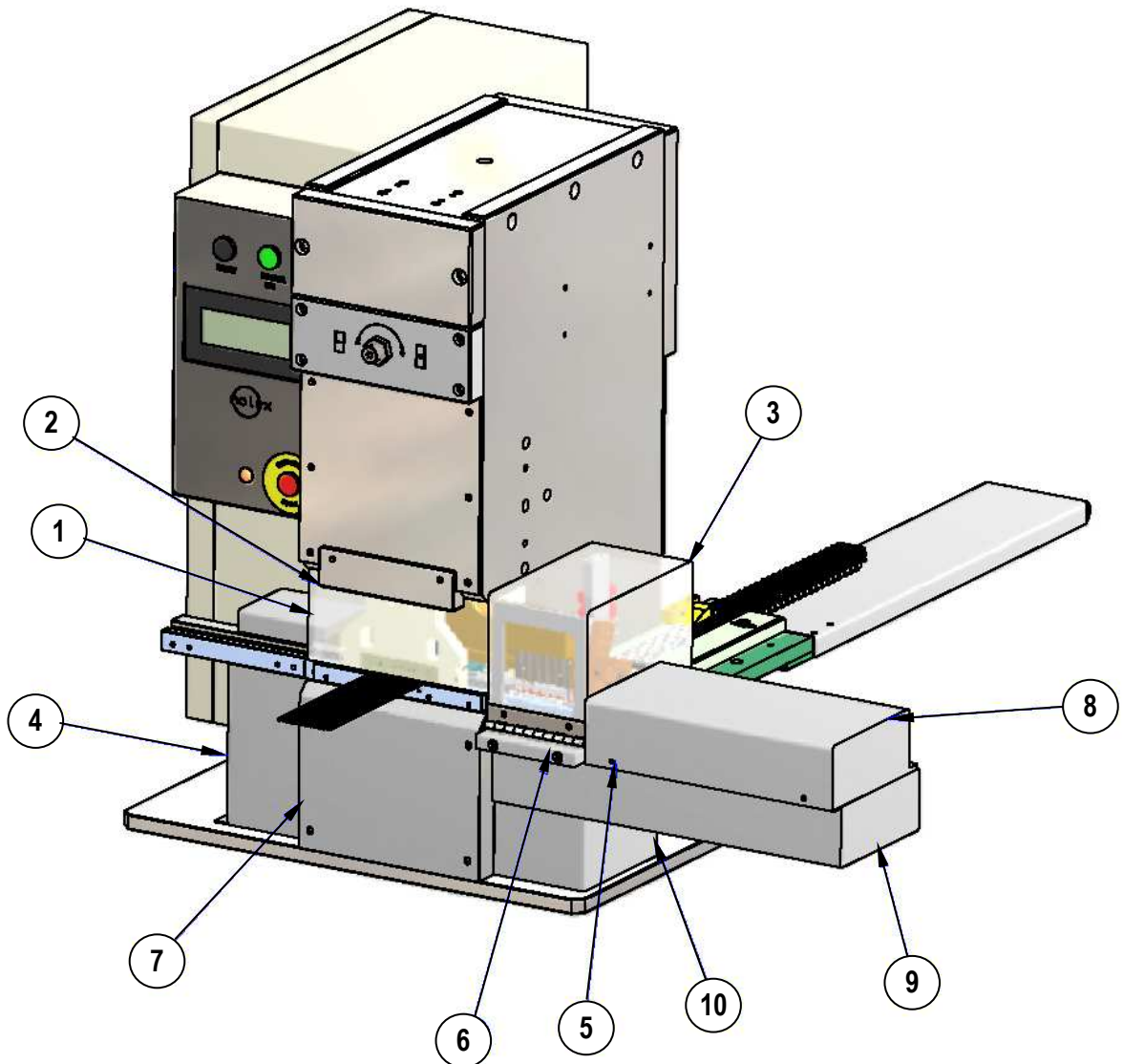

Frame Assembly

Frame Assembly 62300-6006			
Item	Order No.	Description	Qty
1	62300-6023	Left Frame Upright	1
2	62300-6024	Right Frame Upright	1
3	62300-6259	Termination Slide Mtg. Plate	1
4	62300-6249	Back Frame Upright	1
5	62300-6250	Top Plate	1
6	62300-6251	Gusset	2
7	62300-6252	Termination Adjust Plate	1
8	62300-6253	Top Front Plate	1
9	623006254	Back Cover Plate	1
10	62300-6022	Front Cover Plate	1
11	623006255	Guide Plate	1
12	62300-6256	In-Feed Table Mtg. Plate	2
13	62300-6257	Cylinder Mtg. Plate	1
14	62300-6021	Main Track Mtg. Plate	1
15	62300-6258	Cut Loose St Support Plate	1
16	62300-6260	Rear Hinged Cover	1
17	62300-6020	Hinge Mtg. Plate	1
18	N/A	Transfer Cylinder- Festo -DSNU 20-150-PPV-A-S10	1
19	N/A	Floating Joint- Festo -2062_FK_M8	1
20	N/A	Hard Stop- Misumi -ANB 16-65	1
21	N/A	Nut- Misumi -ANN 16	1
22	N/A	Stepped Hinge- Misumi -HHSD5	1
23	N/A	Foot Mtg.- Festo -HBN-20-25x2	2

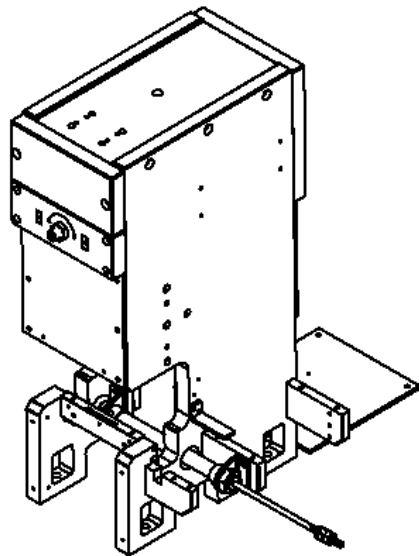

Frame Assembly

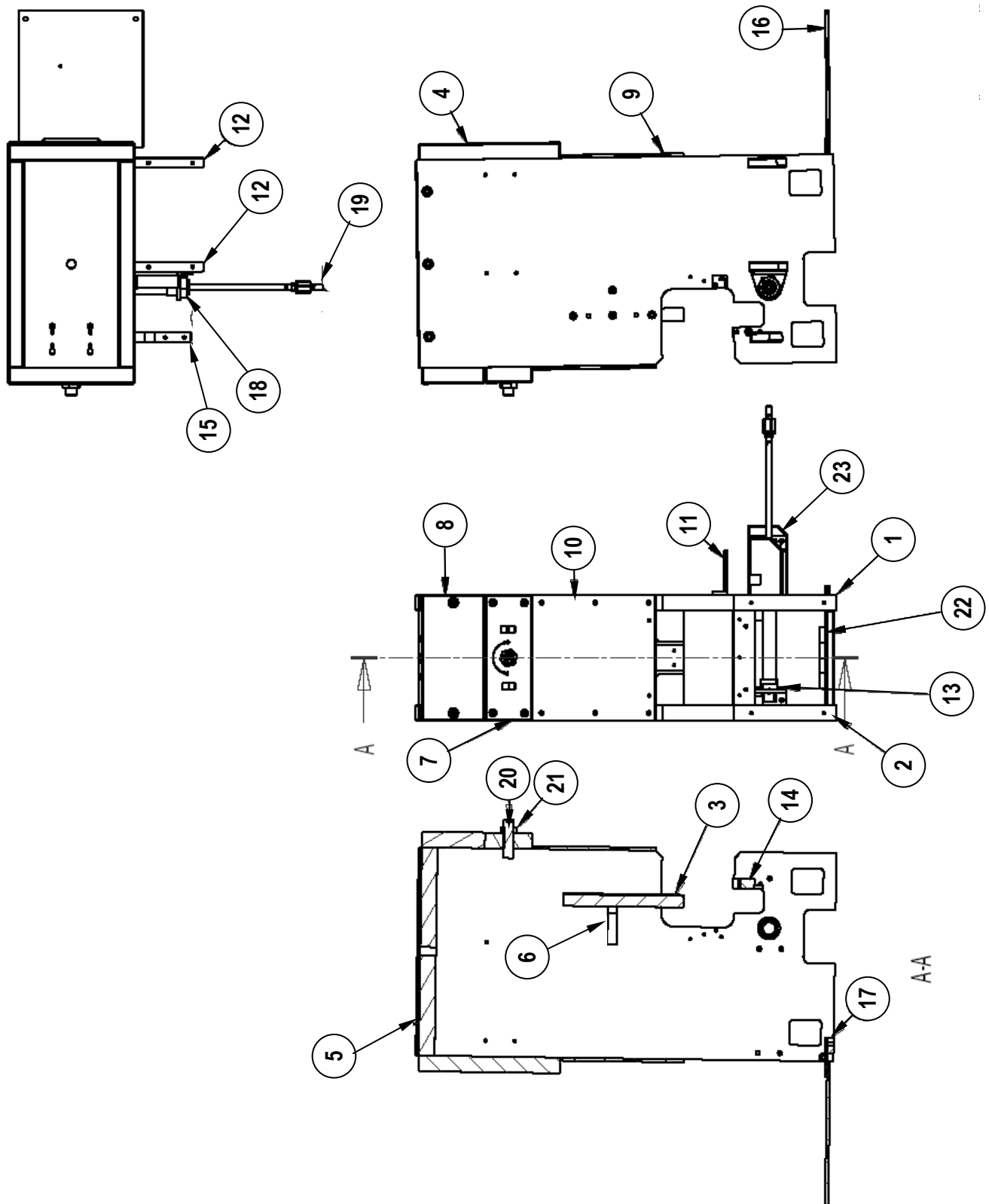

Toggle Joint Assembly

Toggle Joint Assembly 62300-6007			
Item	Order No.	Description	Qty.
1	62300-6261	Fixed Pivot Pin	1
2	62300-6262	Cylinder Pivot Block	1
3	62300-6263	Fixed Pivot Block	2
4	62300-6264	Fixed Link Arm	1
5	62300-6265	Moving Link Arm	1
6	62300-6266	Toggle Joint	1
7	62300-6267	End Plate	1
8	62300-6268	Toggle Joint Pivot Pin	1
9	62300-6269	Brass Washer	1
11	N/A	Mtg. Accessory- Festo -SUA-80	1
12	N/A	Flange Bushing- Oilite -AMF1521 25	2
13	N/A	Straight Bushing- Oilite -AMC1215-16	2
14	N/A	Straight Bushing- Oilite -AMC1620 12	2
15	N/A	M16 Nut	1
16	N/A	Compact Cylinder- Festo -ADN-80-40-A-P-A	1

Toggle Joint Assembly

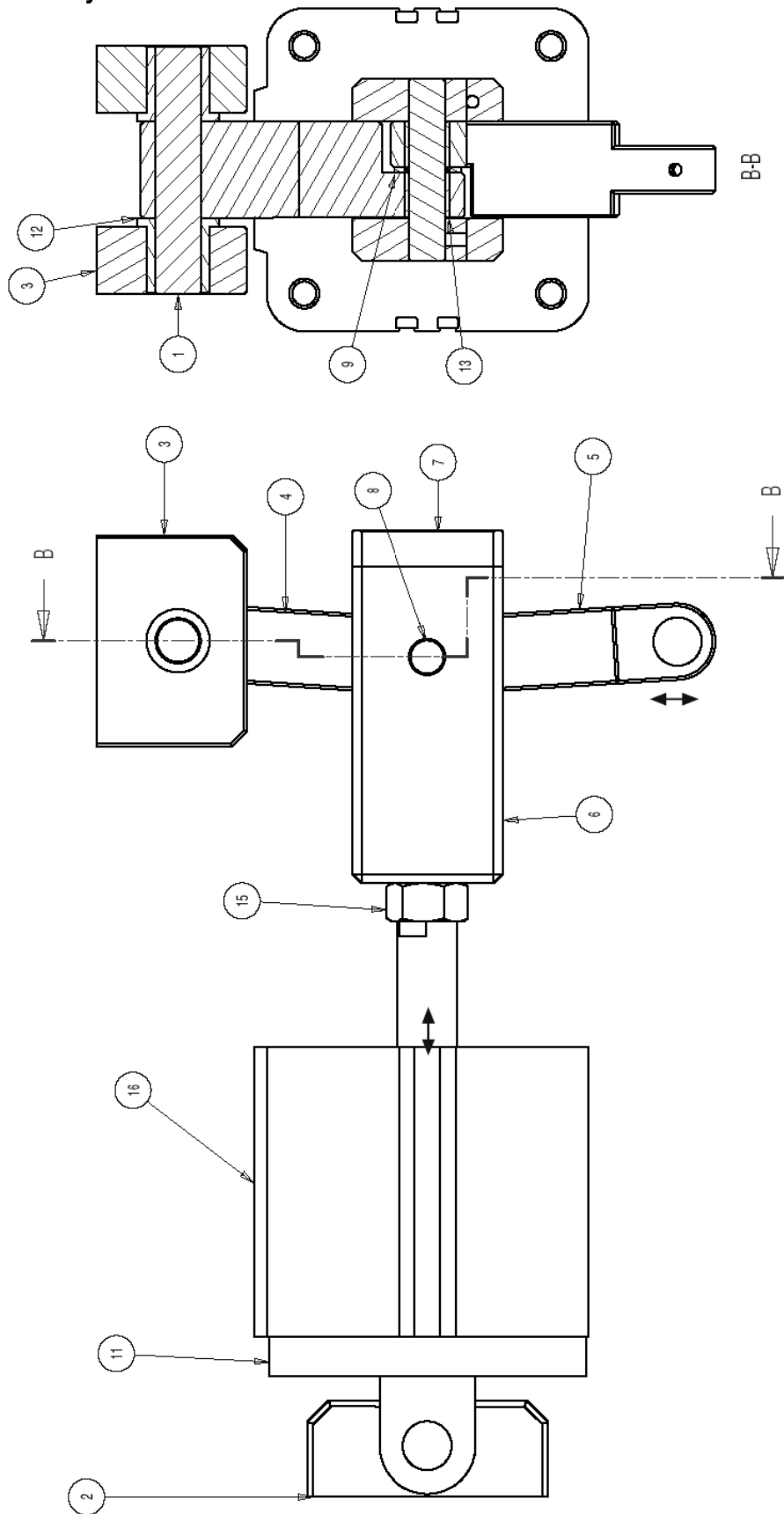

In-Feed Table Assembly

In-Feed Table Assembly 62300-6008			
Item	Order No.	Description	Qty.
1	62300-6025	In-Feed Track Base	1
2	62300-6026	In-Feed Track Front Plate	1
3	62300-6027	Adjustable Side Guide	1
4	62300-6028	Fixed Side Guide	1
5	62300-6281	Cylinder Mtg. Plate	1
6	62300-6029	Transport Rail	1
7	62300-6030	Push Bar Block	1
8	62300-6282	Push Bar End Stop	1
9	62300-6031	Tie Rod Block	1
10	62300-6032	Ejector Pin	1
11	62300-6033	Cut Loose Track	1
12	62300-6034	Gateway Track	1
13	62300-6035	Infeed Ramp	1
14	62300-6283	Cylinder Pos Block	2
15	62300-6036	Lever Detect Block	1
16	62300-6037	Lever Detect	1
17	62300-6038	Track Spacer	1
18	62300-6284	Rail Support Block	2
19	62300-6039	Lever Detect Pin	1
20	N/A	Carriage- SKF - LLBHC15-TATO	1
21	N/A	M5 Proximity Switch - IFRM 05P15A3-S35L	1
22	N/A	Cylinder- Festo - DZF-12-70-A-P-A	1
23	N/A	Floating Joint- Festo -2061 FK-M6-(0;0)	1
24	N/A	Handle- Ganter Griff - GN 300.1-45 m6-32-bkl	2
25	62300-6040	Infeed Support	1
26	62300-6041	Infeed Support Bkt.	1

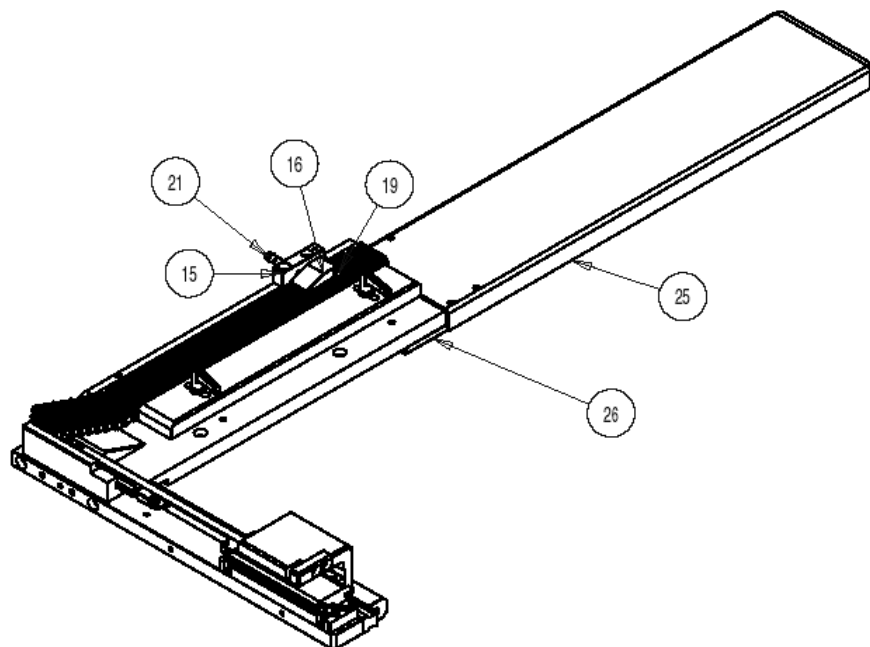

In-Feed Table Assembly

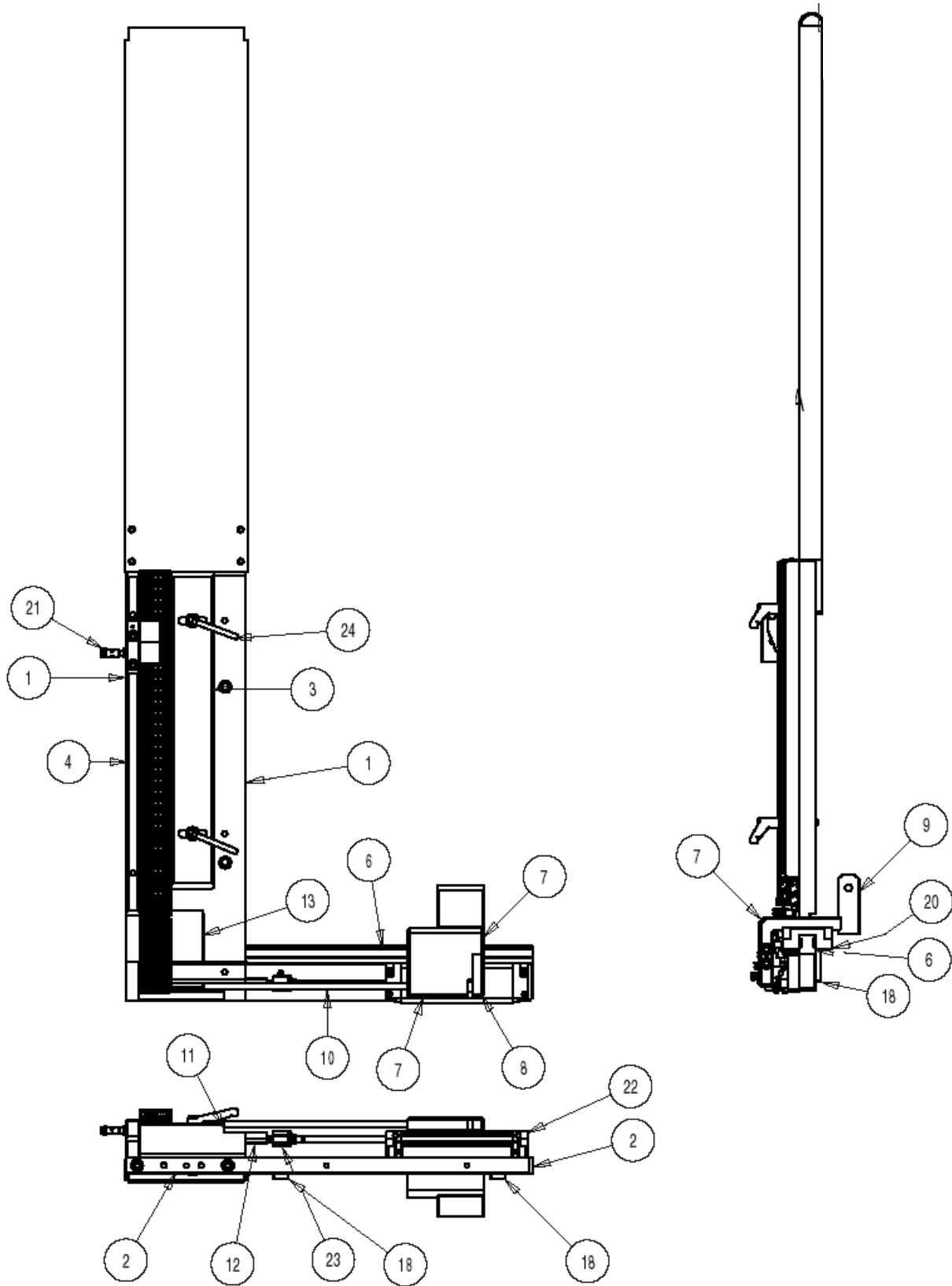

Cut and Termination Assembly

Cut and Term Slide Assembly 62300-6009			
Item	Order No.	Description	Qty.
1	62300-6043	Cut and Termination Tooling Plate	1
2	62300-6286	Toggle To Slide Linkage	1
3	62300-6001	Housing Cut Blade	1
4	62300-6002	Termination Tool	1
5	62300-6287	Toggle Joint Pin	1
6	62300-6288	Cut and Termination Tooling Key	2
7	62300-6289	Brass Washer	2
8	▪ 62300-6003	Connector Support Blade (12 circuit)	1
9	62300-6290	Termination Insert	1
10	N/A	Rail and Carriage- THK -SRS15WMUU+190L	1
11	N/A	Bush- Oilite -AMC1620 12	2
---	62300-6042	MX424116-05	1

▪ Other Termination Support Blade Sizes		
Order No.	Description	Circuit Size
62300-6073	Connector Support Blade	2
62300-6074	Connector Support Blade	3
62300-6075	Connector Support Blade	4
62300-6076	Connector Support Blade	5
62300-6077	Connector Support Blade	6
62300-6078	Connector Support Blade	7
62300-6079	Connector Support Blade	8
62300-6080	Connector Support Blade	9
62300-6081	Connector Support Blade	10
62300-6082	Connector Support Blade	11
62300-6083	Connector Support Blade Set	2-12

Cut and Termination Assembly

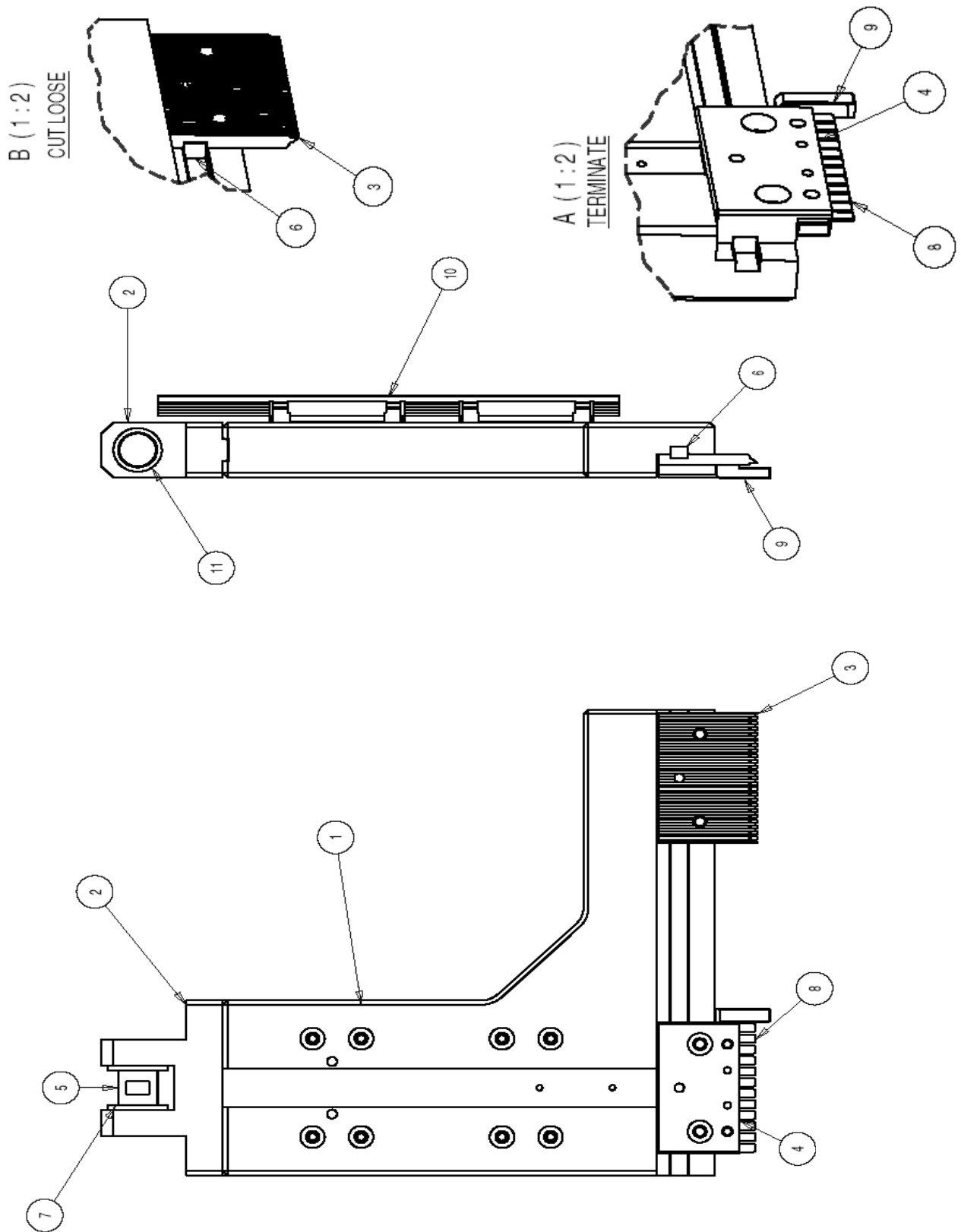

Connector Feed Clamp Assembly

In-Feed Gripper Assembly 62300-6010			
Item	Order No.	Description	Qty.
1	62300-6291	Infeed Cylinder Mtg. Plate	1
2	623006044	Fixed Clamp Plate	1
3	62300-6293	Adjustable Clamp Plate	1
4	62300-6294	Clamp Cylinder Plate	1
5	623006045	Infeed Moving Clamp	1
6	623006046	Cylinder Spacer Block	1
7	623006047	Cylinder Spacer Block	1
8	N/A	Thumbscrew- Ganter Griff -DIN 653-M6-16	1
9	N/A	Cylinder- Festo- DFM-16-20-P-A-GF	1
10	N/A	Compact Cylinder- Festo -ADVUL-16-5-P-A	1

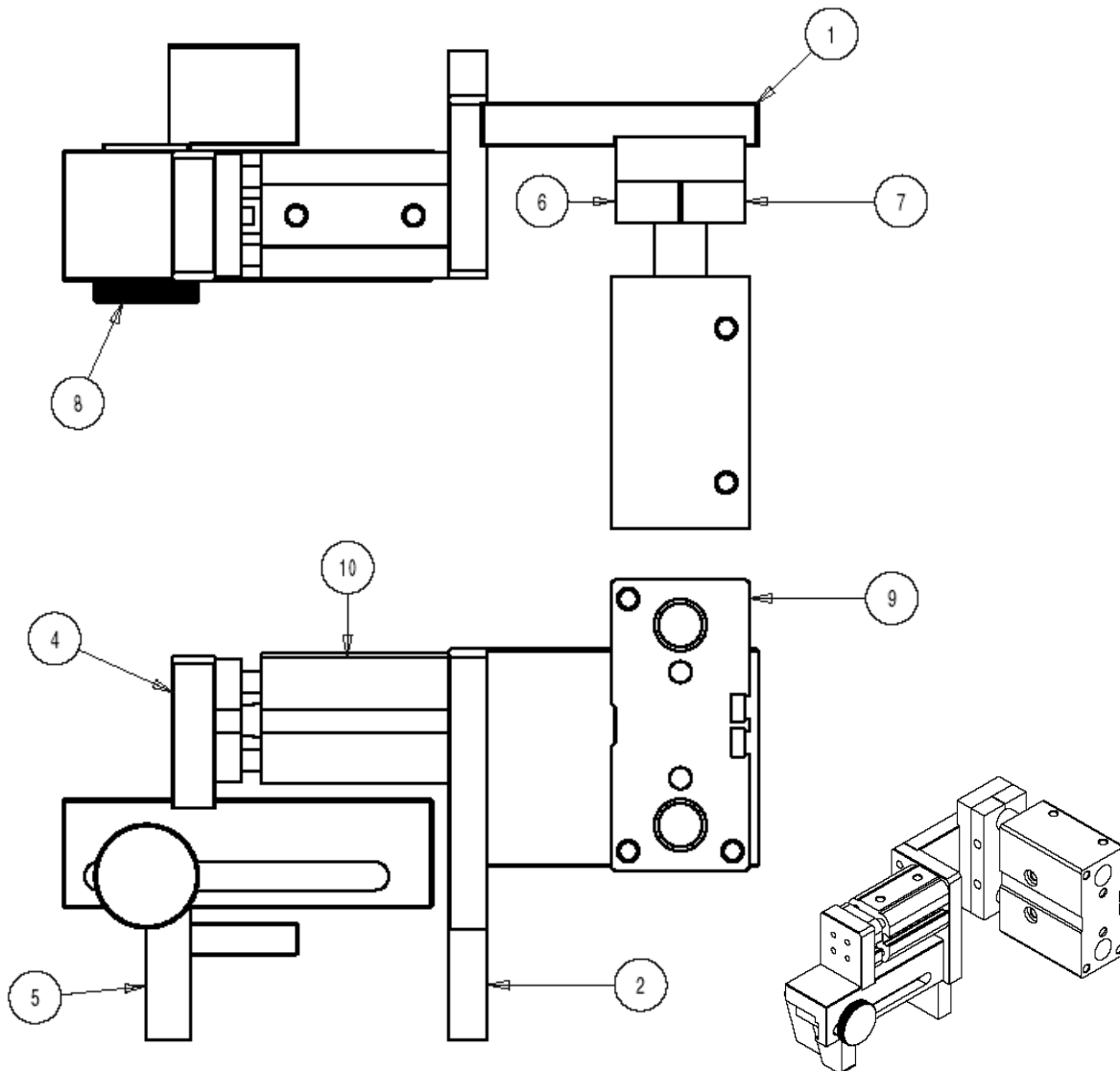

Laser Sensor Assembly

Laser Sensor Assembly 62300-6011			
Item	Order No.	Description	Qty.
1	62300-6298	Mounting Feet	2
2	62300-6048	Laser Bracket	
3	N/A	Festo Unit (<i>Items 5 thru 8</i>) View B	REF
4	N/A	Laser Sensor- ANR11	1
5	N/A	Coupling- Festo -KSE-15-22-D04-D05	1
6	N/A	Stepper Motor- Festo -MTR-ST-42-48S-AA	1
7	N/A	Flange- Festo -MTR-FL30-ST42	1
8	N/A	Linear Unit- Festo -DGE-12-100-ZR-LV-RV-GK-KF-KG	1

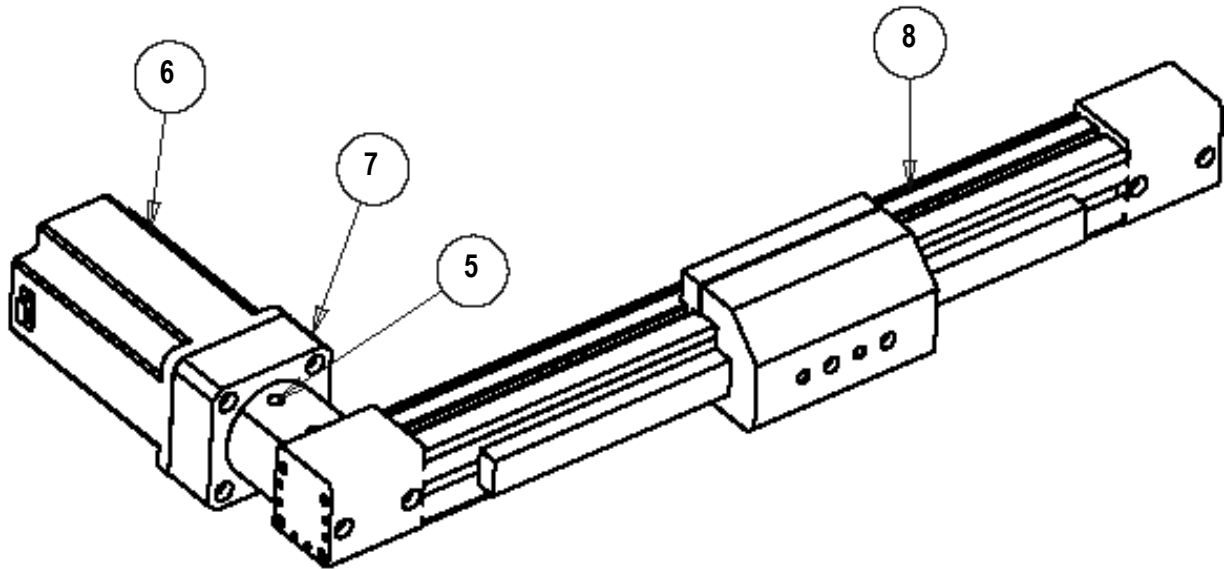

VIEW B

Laser Sensor Assembly

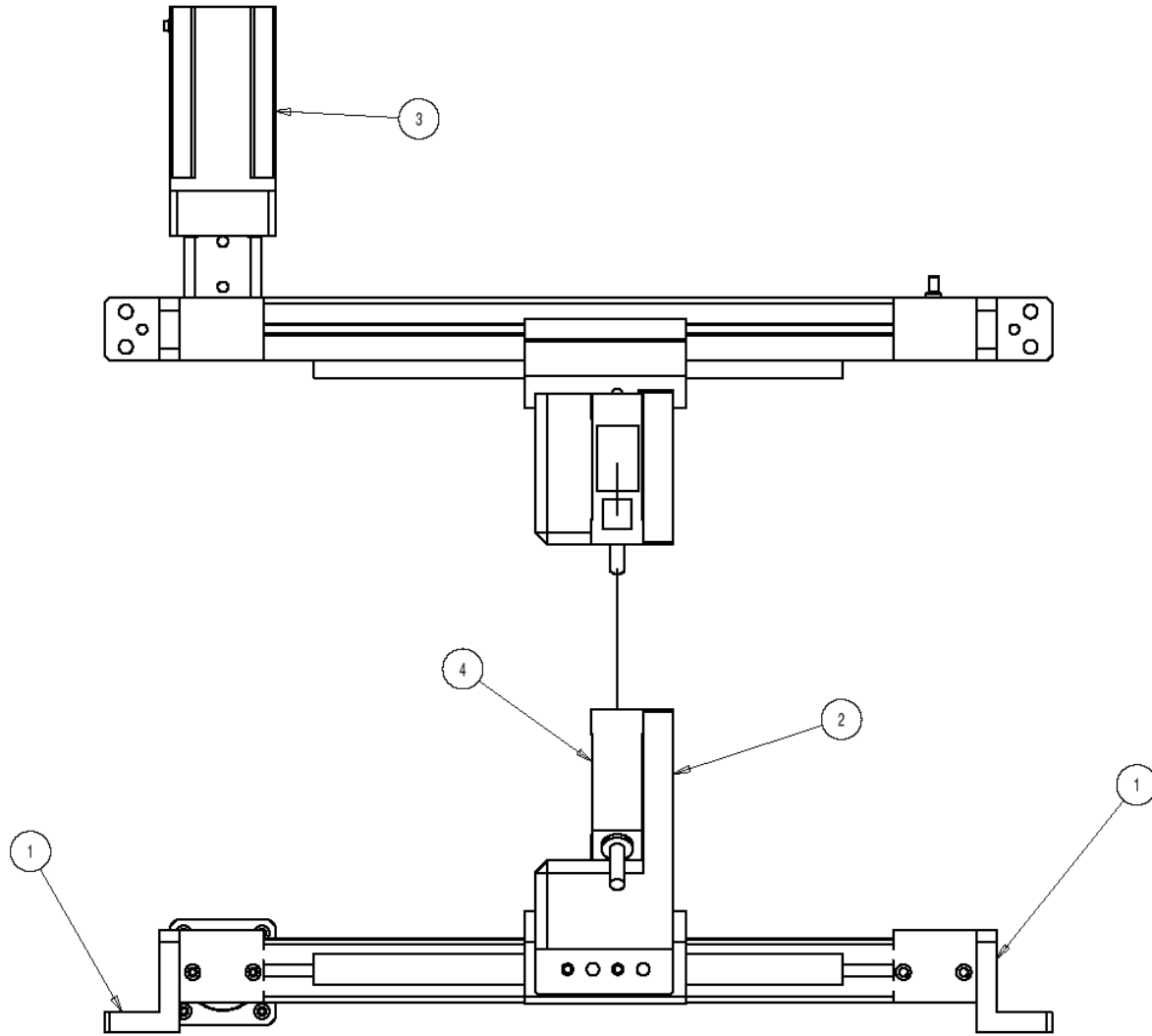

Termination Track Assembly

Terminator Track Assembly 62300-6012			
Item	Order No.	Description	Qty.
1	62300-6049	Main Feed Track	1
2	62300-6050	In-Feed Cover	1
3	62300-6051	Out-Feed Cover	1
4	62300-6052	Left Push Finger	1
5	62300-6053	Right Push Finger	1
6	62300-6054	Comb Tooling	1
7	62300-6055	Brake	1
8	62300-6056	Cover Insert	1
9	62300-6057	Track Insert	1
10	62300-6058	Laser Reflect Plate	1
11	N/A	C-Spring Entex #3302	1
12	N/A	C-Spring Entex #3166	2
13		Dowel Pin-Ø4.00 g6 x 25mm	2
14	REF	Customer Product- Rast 2.5-12cct.	1

Termination Track Assembly

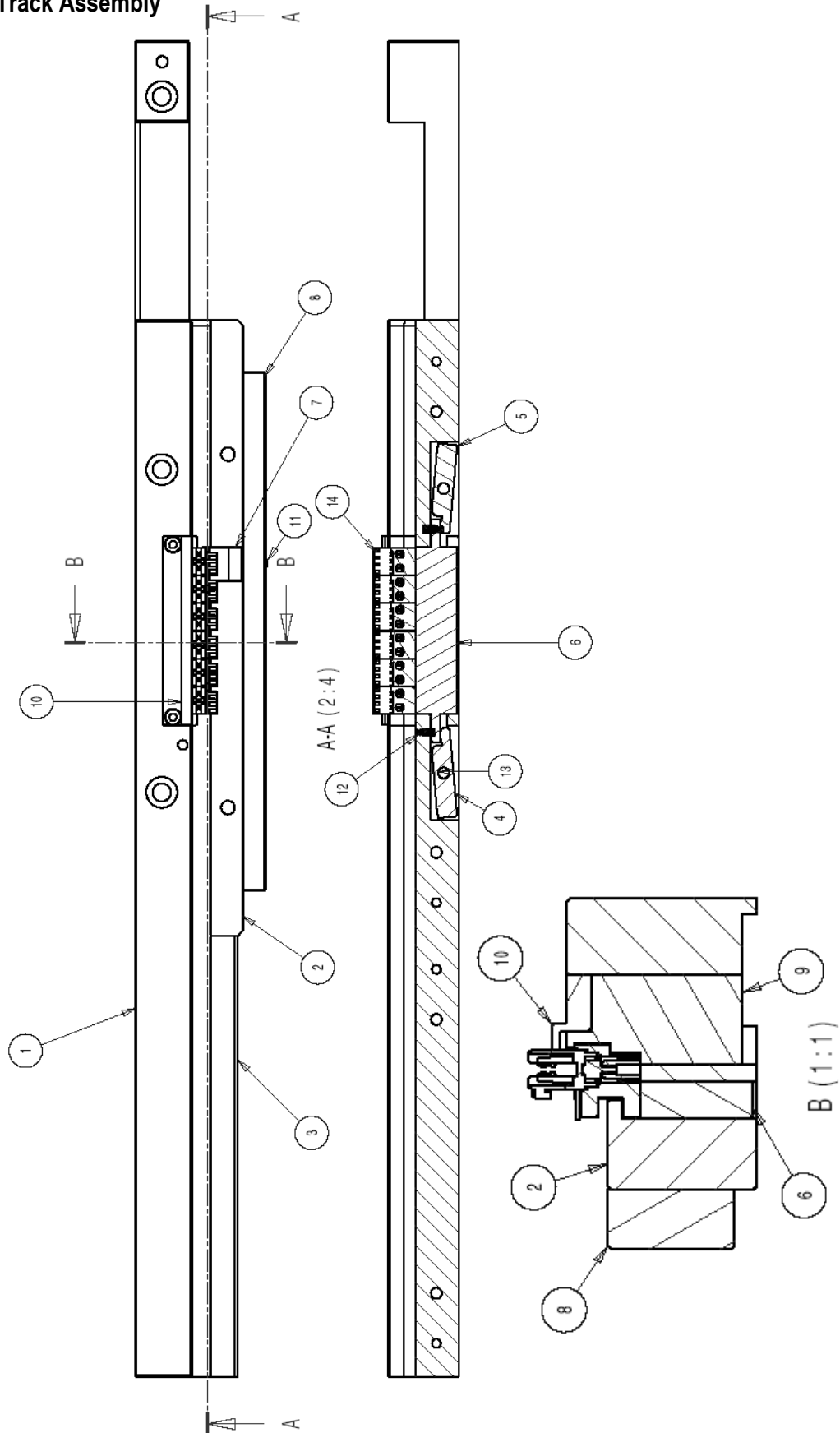

Cable Mask Tooling Assembly

Cable Mask Tooling 62300-6013			
Item	Order No.	Description	Qty.
1	62300-6059	Main Slide Plate	1
2	62300-6060	Cylinder Clevis Block	1
3	62300--6415	Floating Joint	1
4	62300--6416	Gripper Pivot Pin	1
5	62300-6063	Cable Mask Tooling	1
6	62300-6064	Spring Retaining Block	1
7	62300-6127	Comb Tooling Trigger Pin	2
8	62300-6066	Mask Tooling Grip Insert	12
9	N/A	Rail and Carriage- THK -SRS 9W	1
10	N/A	Cylinder- Festo -DMM-20-20-P-A	1
11	N/A	Compression Spring- Entex - #3094	12

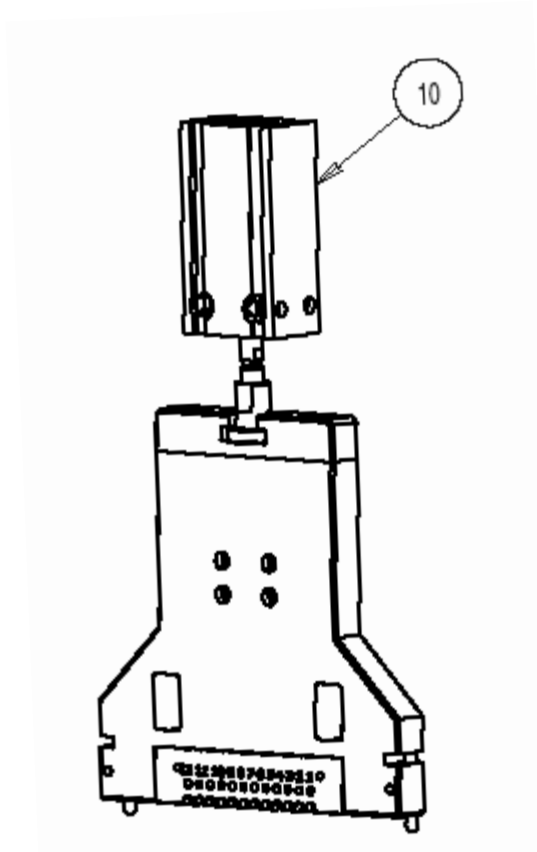

Cable Mask Tooling Assembly

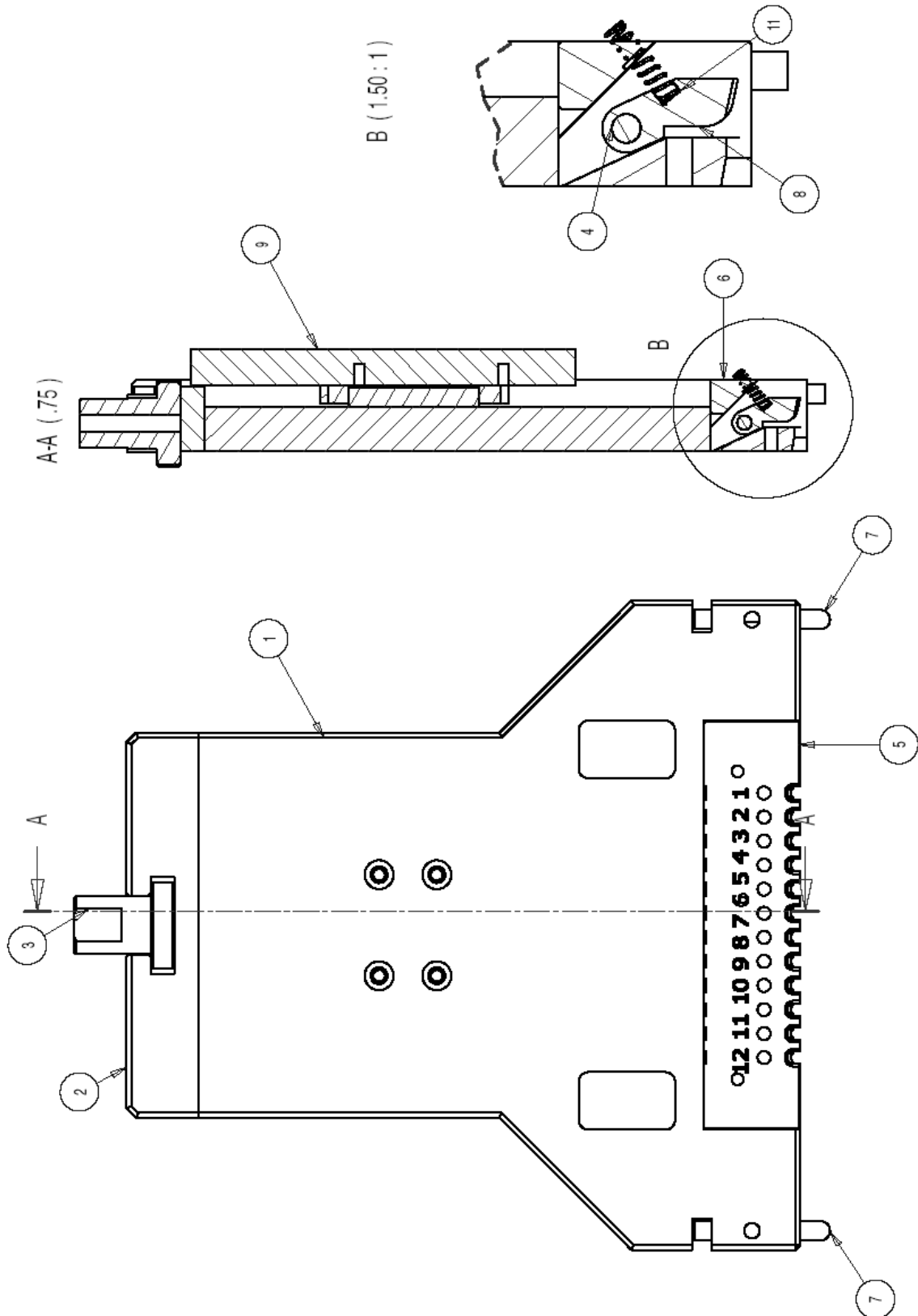

Out-Feed Pawl Assembly

Out-Feed Pawl Assembly 62300-6214			
Item	Order No.	Description	Qty.
1	62300-6029	Transport Rail	1
2	62300-6068	Out-Feed Pawl Mtg. Plate	1
3	62300-6069	Out-Feed Pawl Body	1
4	62300-6004	Out-Feed Pawl	1
5	62300-6070	Adjustment Block	1
6	62300-6071	Pawl Pivot Pin	1
7	N/A	Tie Rod - Misumi - LBRFNF6-254.5-10-PC-QC	1
8	N/A	Floating Joint- Festo -2061 FK-M6-(0;0)	2
9	N/A	Compression Spring- Entex- #903	1
10	N/A	Hard Stop- Misumi -ANB 4-25	1
11	N/A	Nut- Misumi -ANN 4	1
12	N/A	Carriage- SKF- LLBHC15-TATO	1

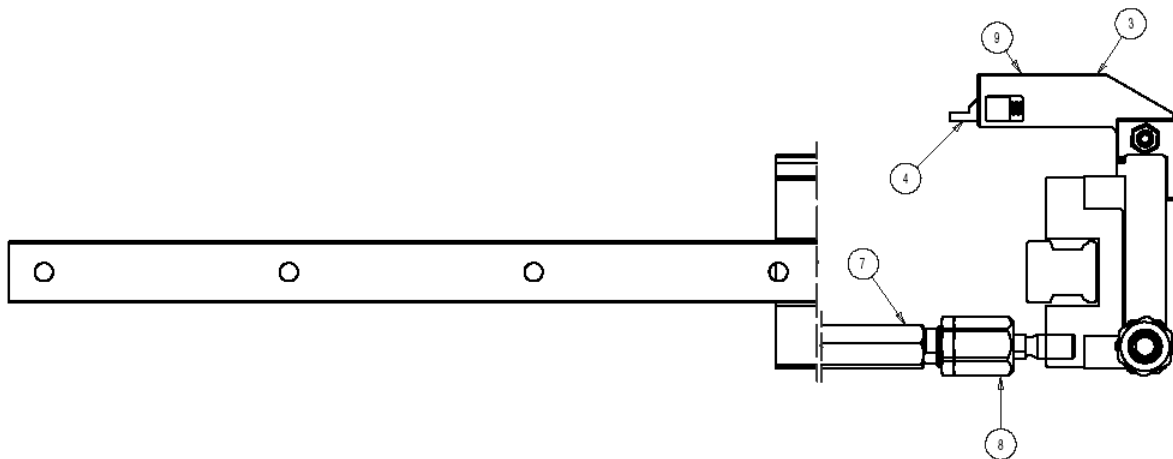

5.2 Electrical Parts List

BILL OF MATERIALS

ITEM	QUANTITY	DESCRIPTION	UNIT	PRICE	EXT. PRICE	DATE	REVISION
1.0	1	TERMINATOR					
1.1	1	BUZZER					
1.2	1	WIRE ASSEMBLY					
1.3	1	WIRE ASSEMBLY					
1.4	1	WIRE ASSEMBLY					
1.5	1	WIRE ASSEMBLY					
1.6	1	WIRE ASSEMBLY					
1.7	1	WIRE ASSEMBLY					
1.8	1	WIRE ASSEMBLY					
1.9	1	WIRE ASSEMBLY					
1.10	1	WIRE ASSEMBLY					
1.11	1	WIRE ASSEMBLY					
1.12	1	WIRE ASSEMBLY					
1.13	1	WIRE ASSEMBLY					
1.14	1	WIRE ASSEMBLY					
1.15	1	WIRE ASSEMBLY					
1.16	1	WIRE ASSEMBLY					
1.17	1	WIRE ASSEMBLY					
1.18	1	WIRE ASSEMBLY					
1.19	1	WIRE ASSEMBLY					
1.20	1	WIRE ASSEMBLY					
1.21	1	WIRE ASSEMBLY					
1.22	1	WIRE ASSEMBLY					
1.23	1	WIRE ASSEMBLY					
1.24	1	WIRE ASSEMBLY					
1.25	1	WIRE ASSEMBLY					
1.26	1	WIRE ASSEMBLY					
1.27	1	WIRE ASSEMBLY					
1.28	1	WIRE ASSEMBLY					
1.29	1	WIRE ASSEMBLY					
1.30	1	WIRE ASSEMBLY					
1.31	1	WIRE ASSEMBLY					
1.32	1	WIRE ASSEMBLY					
1.33	1	WIRE ASSEMBLY					
1.34	1	WIRE ASSEMBLY					
1.35	1	WIRE ASSEMBLY					
1.36	1	WIRE ASSEMBLY					
1.37	1	WIRE ASSEMBLY					
1.38	1	WIRE ASSEMBLY					
1.39	1	WIRE ASSEMBLY					
1.40	1	WIRE ASSEMBLY					
1.41	1	WIRE ASSEMBLY					
1.42	1	WIRE ASSEMBLY					
1.43	1	WIRE ASSEMBLY					
1.44	1	WIRE ASSEMBLY					
1.45	1	WIRE ASSEMBLY					
1.46	1	WIRE ASSEMBLY					
1.47	1	WIRE ASSEMBLY					
1.48	1	WIRE ASSEMBLY					
1.49	1	WIRE ASSEMBLY					
1.50	1	WIRE ASSEMBLY					
1.51	1	WIRE ASSEMBLY					
1.52	1	WIRE ASSEMBLY					
1.53	1	WIRE ASSEMBLY					
1.54	1	WIRE ASSEMBLY					
1.55	1	WIRE ASSEMBLY					
1.56	1	WIRE ASSEMBLY					
1.57	1	WIRE ASSEMBLY					
1.58	1	WIRE ASSEMBLY					
1.59	1	WIRE ASSEMBLY					
1.60	1	WIRE ASSEMBLY					
1.61	1	WIRE ASSEMBLY					
1.62	1	WIRE ASSEMBLY					
1.63	1	WIRE ASSEMBLY					
1.64	1	WIRE ASSEMBLY					
1.65	1	WIRE ASSEMBLY					
1.66	1	WIRE ASSEMBLY					
1.67	1	WIRE ASSEMBLY					
1.68	1	WIRE ASSEMBLY					
1.69	1	WIRE ASSEMBLY					
1.70	1	WIRE ASSEMBLY					
1.71	1	WIRE ASSEMBLY					
1.72	1	WIRE ASSEMBLY					
1.73	1	WIRE ASSEMBLY					
1.74	1	WIRE ASSEMBLY					
1.75	1	WIRE ASSEMBLY					
1.76	1	WIRE ASSEMBLY					
1.77	1	WIRE ASSEMBLY					
1.78	1	WIRE ASSEMBLY					
1.79	1	WIRE ASSEMBLY					
1.80	1	WIRE ASSEMBLY					
1.81	1	WIRE ASSEMBLY					
1.82	1	WIRE ASSEMBLY					
1.83	1	WIRE ASSEMBLY					
1.84	1	WIRE ASSEMBLY					
1.85	1	WIRE ASSEMBLY					
1.86	1	WIRE ASSEMBLY					
1.87	1	WIRE ASSEMBLY					
1.88	1	WIRE ASSEMBLY					
1.89	1	WIRE ASSEMBLY					
1.90	1	WIRE ASSEMBLY					
1.91	1	WIRE ASSEMBLY					
1.92	1	WIRE ASSEMBLY					
1.93	1	WIRE ASSEMBLY					
1.94	1	WIRE ASSEMBLY					
1.95	1	WIRE ASSEMBLY					
1.96	1	WIRE ASSEMBLY					
1.97	1	WIRE ASSEMBLY					
1.98	1	WIRE ASSEMBLY					
1.99	1	WIRE ASSEMBLY					
1.100	1	WIRE ASSEMBLY					

COMPONENTS 1

PARTNAME	UNIT/FIG	CAT	CATDESC
#CABINET-01	MUELLER	U-2-17EZ	3 POLE ROTARY CAM SWITCH
#FRAME-GS1	QUARMASTER	440N-S32022	SIPHA BOARD SWITCH SIZ
#FRAME-SU02			
#LASER-DS1	FESTO	MRE-S1-42-48S-44	STEPPER MOTOR
	FESTO	MTR-FL30-ST42	MOTOR FLANGE
	FESTO	KSE-15-22-004-D05	COUPLING
	FESTO	DGE-12-100-ZR-LK-KG-KF-GK	TOOTHED BELT AXIS
	FARNELL	107-5228	Solder Bucket Socket [9 Way]
	FARNELL	430-3430	THE FAST SUB BOARD [9 WAY]
#LASER-DV2	FANASSONIC	VAL-50S-1	DISPLACEMENT LASER SENSOR
	FANASSONIC	4NR313	DISPLACEMENT LASER SENSOR CONTROLLER
#MANIFOLD1-SU01.0	SMC	SV1100-SFU	7/2 WAY SOLENOID VALVE
	SMC	SS5V1-10FDI-08D-C4-D	MANIFOLD
	SMC	SV1000-67-1A	BLANKING PLATE
	SMC	AN200-KMB	PLUG IN SILENCER 8mm
	SMC	KQ2L08-99	PLUG IN ELBOW 8mm
	SMC	KQ2L04-99	PLUG IN ELBOW 4mm
	SMC	KQ2W04-99	EXTENDED PLUG IN ELBOW 4mm
#MANIFOLD1-SU01.2A	SMC	SV1200-SFU	7/2 WAY SOLENOID VALVE
	SMC	KQ2L04-99	PLUG IN ELBOW 4mm
	SMC	KQ2W04-99	EXTENDED PLUG IN ELBOW 4mm
#MANIFOLD1-SU01.2B	SMC	SV1100-SFU	7/2 WAY SOLENOID VALVE
	SMC	KQ2L04-99	PLUG IN ELBOW 4mm
#MANIFOLD1-SU01.3	SMC	KQ2W04-99	EXTENDED PLUG IN ELBOW 4mm
#MANIFOLD1-SU01.4	SMC	SV1100-SFU	7/2 WAY SOLENOID VALVE
	SMC	KQ2L04-99	PLUG IN ELBOW 4mm
#MANIFOLD1-SU01.5	SMC	KQ2W04-99	EXTENDED PLUG IN ELBOW 4mm
	SMC	SV1100-SFU	7/2 WAY SOLENOID VALVE
	SMC	KQ2L04-99	PLUG IN ELBOW 4mm
	SMC	KQ2W04-99	EXTENDED PLUG IN ELBOW 4mm
#TABLE-B0J07	FESTO	SM-8-S-LEU-24	PROXIMITY SWITCH
#TABLE-B0J08	FESTO	SM-M8-3GT-5-PU	PROXIMITY SWITCH SOCKET STRAIGHT
#TABLE-B0J04	FESTO	SM-M8-3GT-5-PU	PROXIMITY SWITCH SOCKET STRAIGHT
#TABLE-B0J05	FESTO	SM-M8-3WD-5-PU	PROXIMITY SWITCH SOCKET RIGHT ANGLE
#TABLE-B0J06	FESTO	SM-8-S-LEU-24	PROXIMITY SWITCH SOCKET STRAIGHT
#TABLE-B0J09	FESTO	SM-M8-3GT-5-PU	PROXIMITY SWITCH SOCKET STRAIGHT
	FESTO	SM-8-S-LEU-24	PROXIMITY SWITCH SOCKET STRAIGHT

COMPONENTS 2

PAGENAME	CNT/CFG	CAT	CATDESC
#TABLE-B010	FESTO	SME-8-S-LE1J-24	PROXIMITY SWITCH
	FESTO	SIM-MB-3GD-5-PU	PROXIMITY SWITCH SOCKET, STRAIGHT
#TABLE-B011	FESTO	SMER-8-20	PLUNGING KIL
	FESTO	SME-8-S-LE1J-24	PROXIMITY SWITCH
	FESTO	SIM-MB-3GD-5-PU	PROXIMITY SWITCH SOCKET, STRAIGHT
#TABLE-B100	FESTO	SMER-8-20	PLUNGING KIL
	FESTO	SME-8-S-LE1J-24	PROXIMITY SWITCH
#TABLE-B101	FESTO	SIM-MB-3GD-5-PU	PROXIMITY SWITCH SOCKET, STRAIGHT
	FESTO	SME-8-S-LE1J-24	PROXIMITY SWITCH
#TABLE-B102	FESTO	SIM-MB-3GD-5-PU	PROXIMITY SWITCH SOCKET, STRAIGHT
	FESTO	SME-8-S-LE1J-24	PROXIMITY SWITCH
#TABLE-B103	FESTO	SME-8-S-LE1J-24	PROXIMITY SWITCH
	FESTO	SIM-MB-3GD-5-PU	PROXIMITY SWITCH SOCKET, STRAIGHT
#TABLE-B104	FESTO	SMI-8F-24V-K7.5-0E	PROXIMITY SWITCH
	FESTO	SIM-MB-3GD-5-PU	PROXIMITY SWITCH SOCKET, STRAIGHT
#TABLE-B105	FESTO	SMI-8F-24V-K7.5-0E	PROXIMITY SWITCH
	FESTO	SIM-MB-3GD-5-PU	PROXIMITY SWITCH SOCKET, STRAIGHT
#TABLE-S1	TELEMECANIQUE	ZB2B54	MUSHROOM HEAD, RED-LATCH TURN TO RELEASE
	TELEMECANIQUE	ZB2B2102	SWITCH BODY
#TABLE-S2	TELEMECANIQUE	ZB2BF102	SWITCH CONTACT
	TELEMECANIQUE	ZB2BA6	PUSH BUTTON MOMENTARY
DV1	OMRON	ZR2BZ101	SWITCH BODY
	OMRON	NT3S-S125BE	SMI, TOUCHSCREEN
ESR1	OMRON	NTPS-CN12V1	PLC TO I/O CONNECTING CABLE
	FILZ	PN02 X3 24VDC	EMERGENCY STOP & GATE MONITORING
G1	OMRON	88V3-120E24	POWER SUPPLY 3A
GND1			
H0002	FARNELL	464-004	24V LED GREEN
H0004	TELEMECANIQUE	ZB4BV7B3	LED BODY
	TELEMECANIQUE	ZB4BV023	PILDT LIGHT HEAD FOR LED
K1104	SMC	AL20-M2K009	RAIN 4JK DUMP VALVE ASSEMBLY
	SMC	AN101-01	SILENCER 1/8"
	SMC	AN200-02	SILENCER 1/4"
P1003	SWD	K333624	Buzzer, Solid State, Panel Mount
PLC1	OMRON	CPM2A-60CD11-D	CPM2A - CPU W/ 60 I/O POINTS
PLC2	OMRON	CPM1A-M4101	CPM1A - ANALOG I/O MODULE
Q2	BERLIN GERIN	260H0102	SOLE 2 AMP MCB
S0L2	SMC	SV3100-SW2R-03	3/2 WAY SOLENOID VALVE
	SMC	AN300-03	SILENCER 3/8"
	SMC	IL-C30-M24F	SOLENOID LEAD WITH M2 FEMALE CONNECTOR
#1	SMC	AX1100-PS23-050	1/2" SOLENOID LEAD WITH M2 FEMALE CONNECTOR
#2	PANASONIC	INCLUDED	3 CORE SIGNAL CABLE
#2	PANASONIC	INCLUDED	3 CORE SIGNAL CABLE

5.2 Electrical Drawings

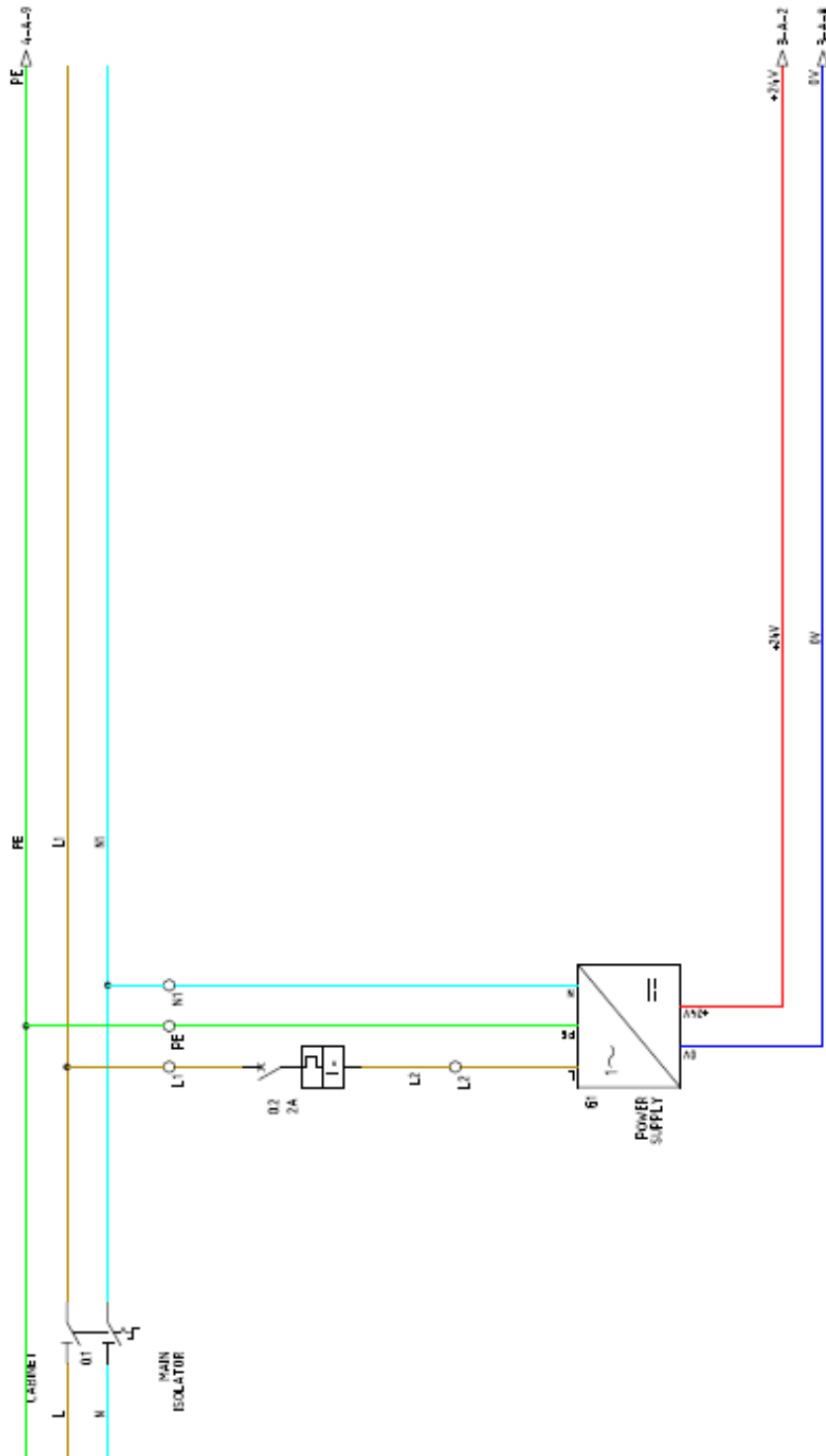

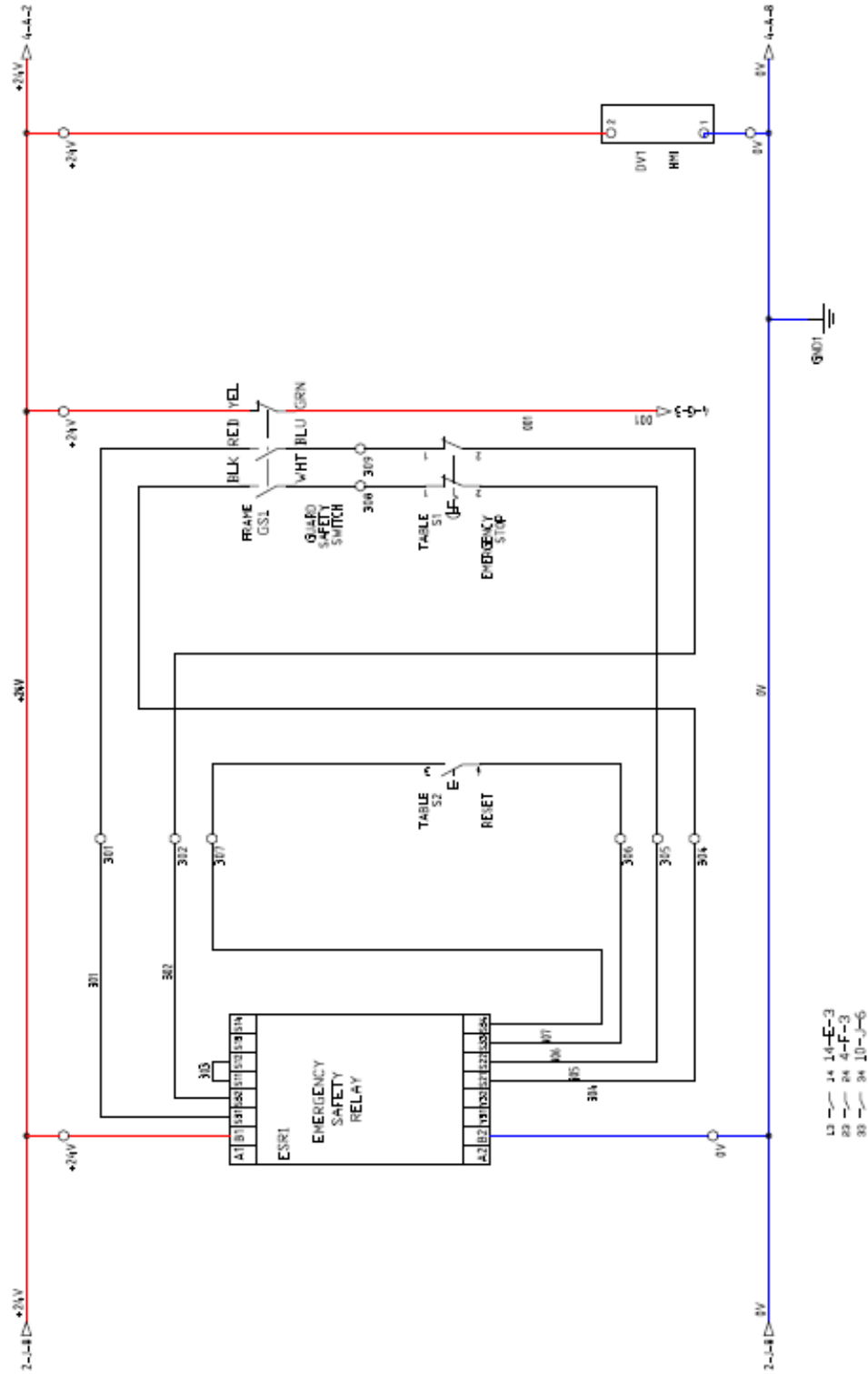

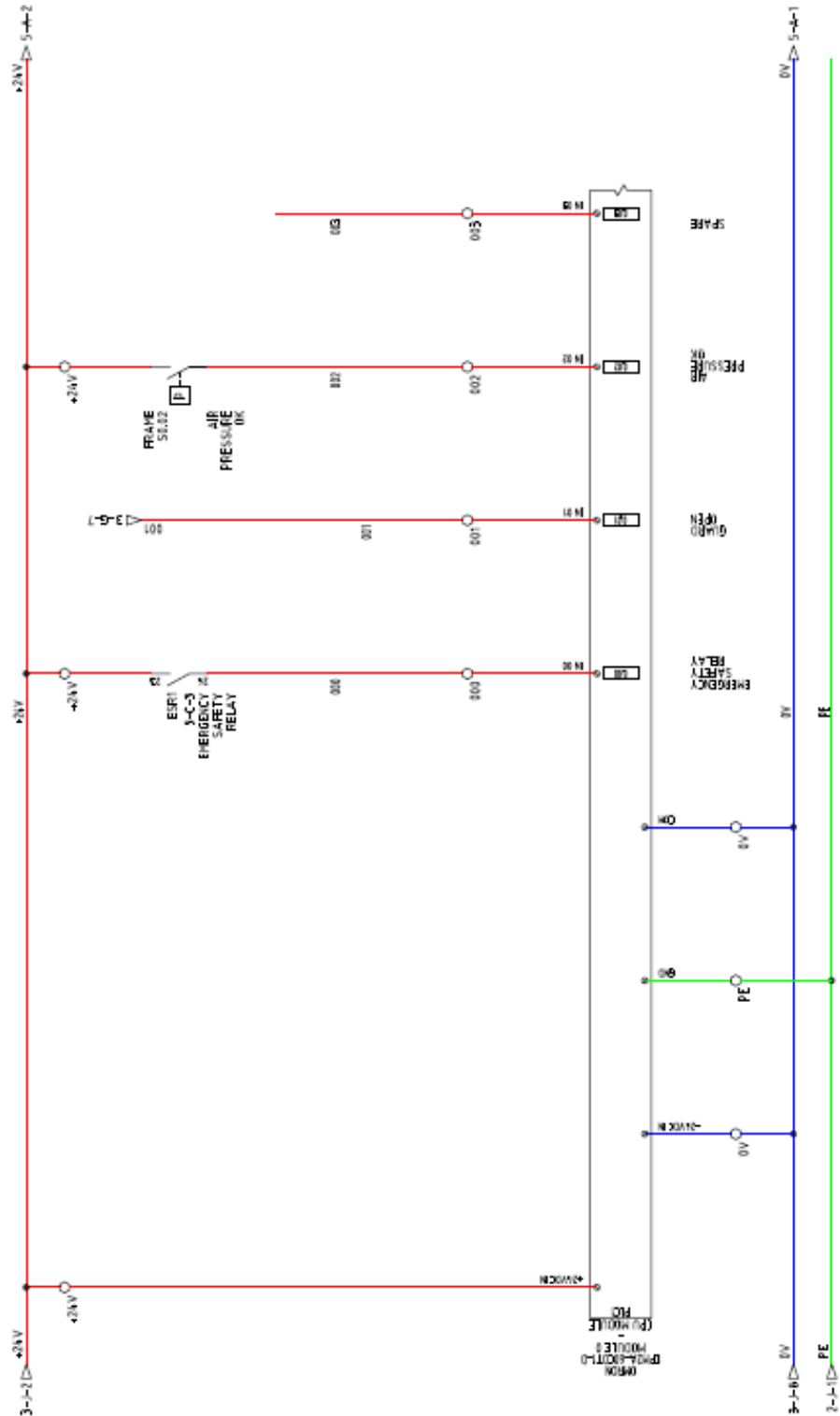

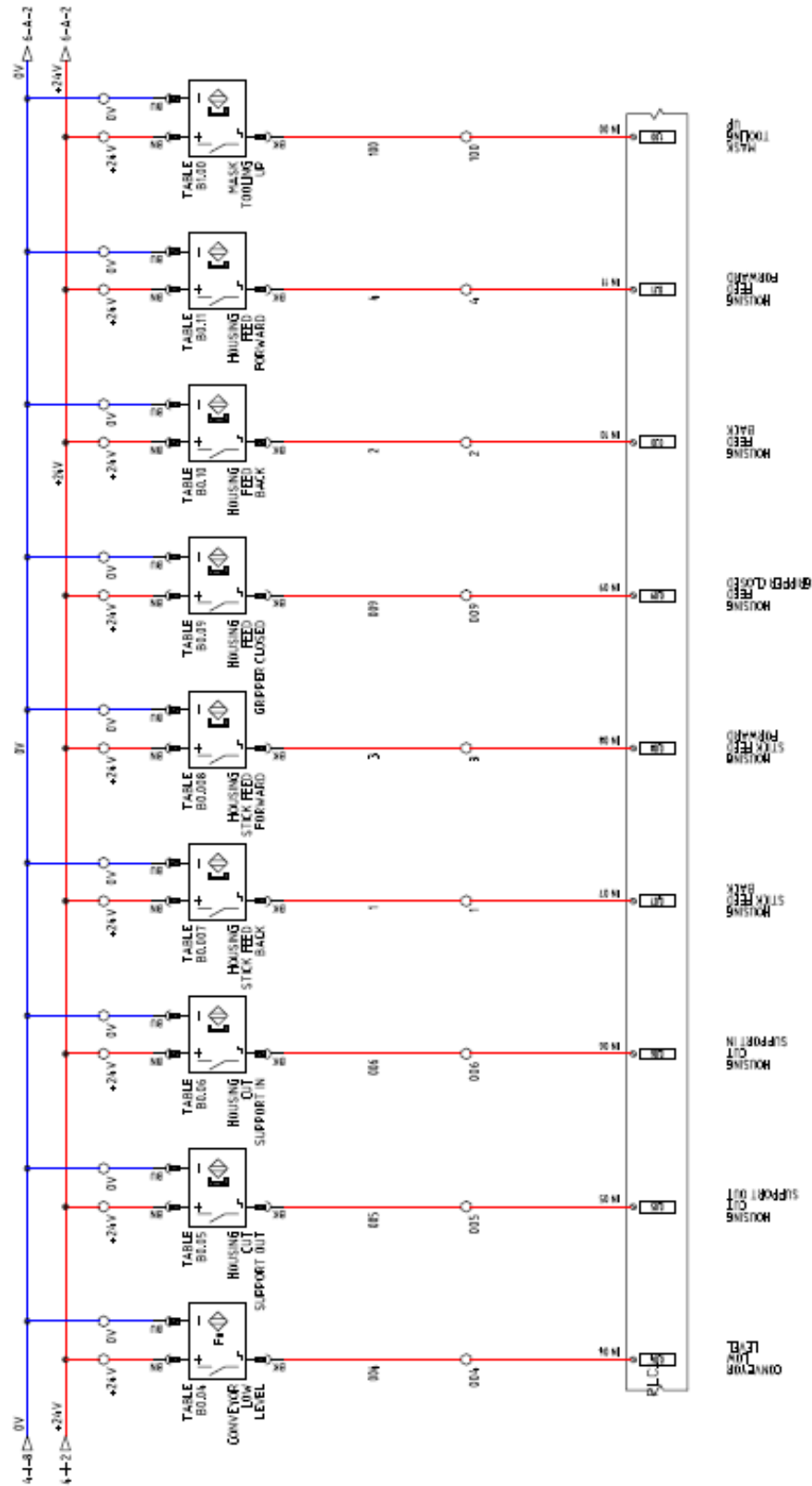

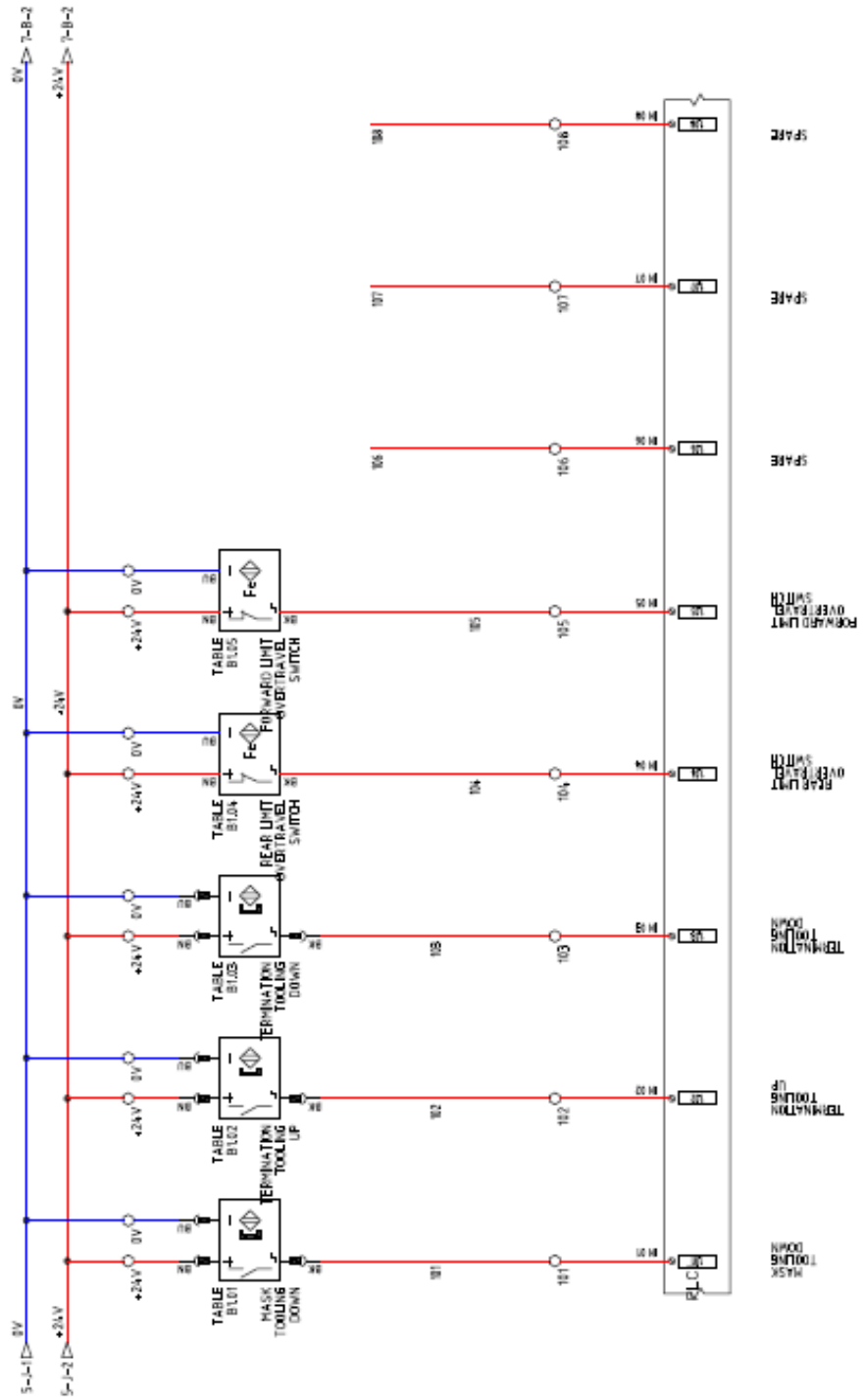

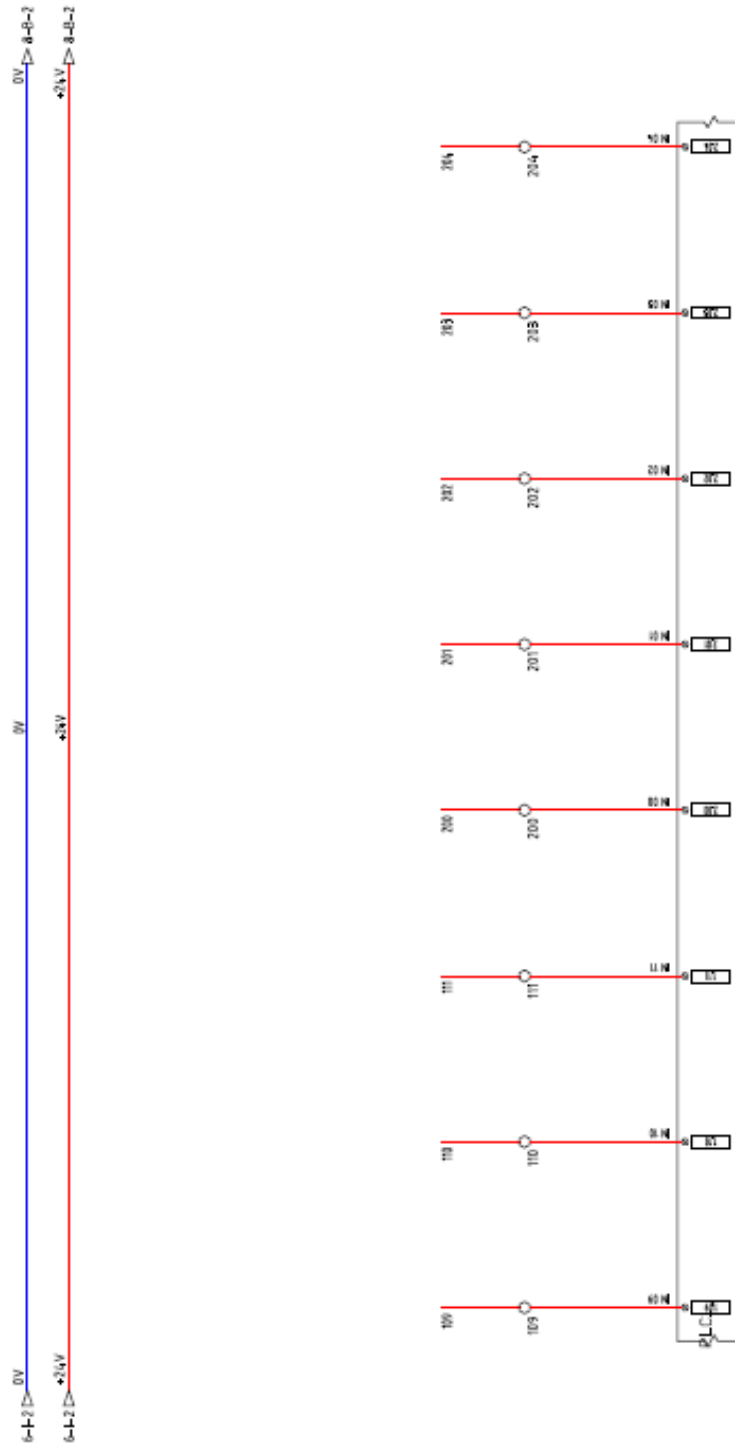

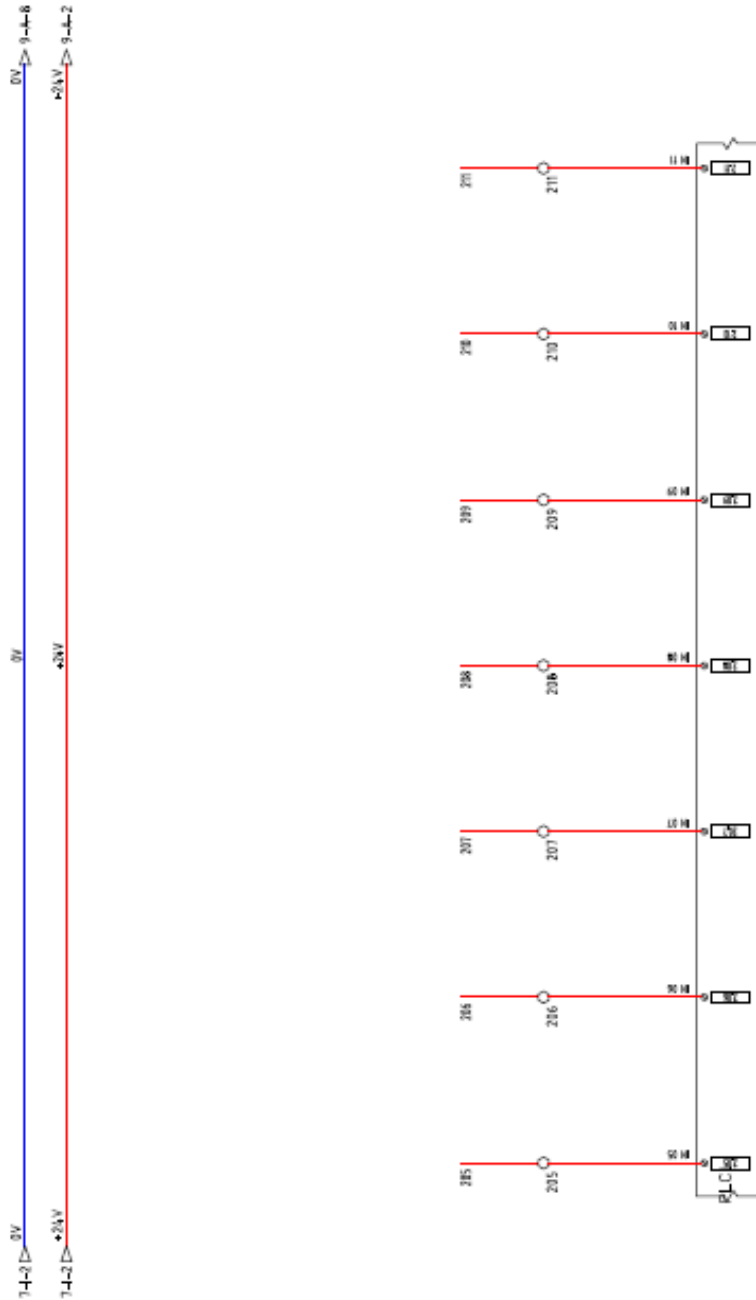

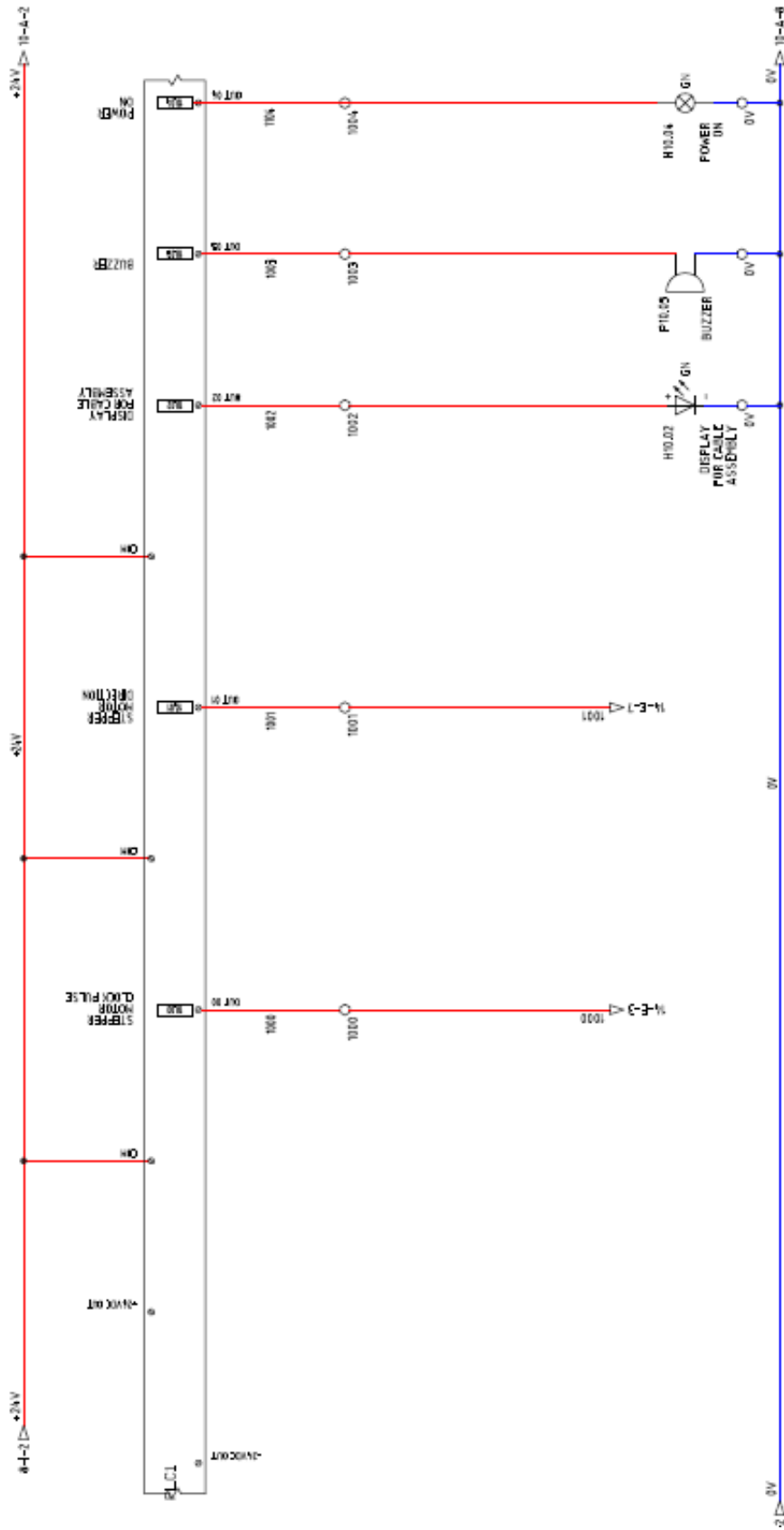

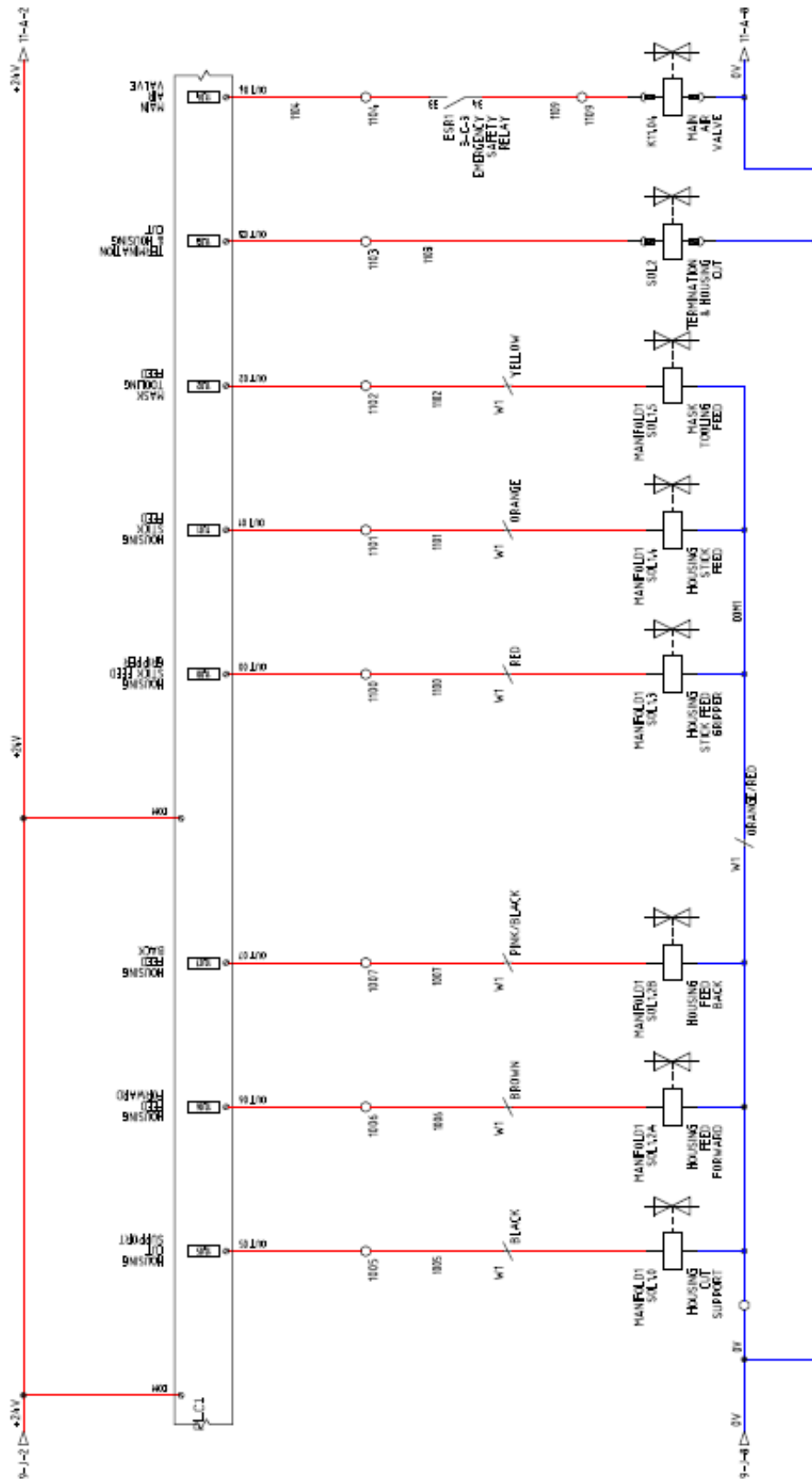

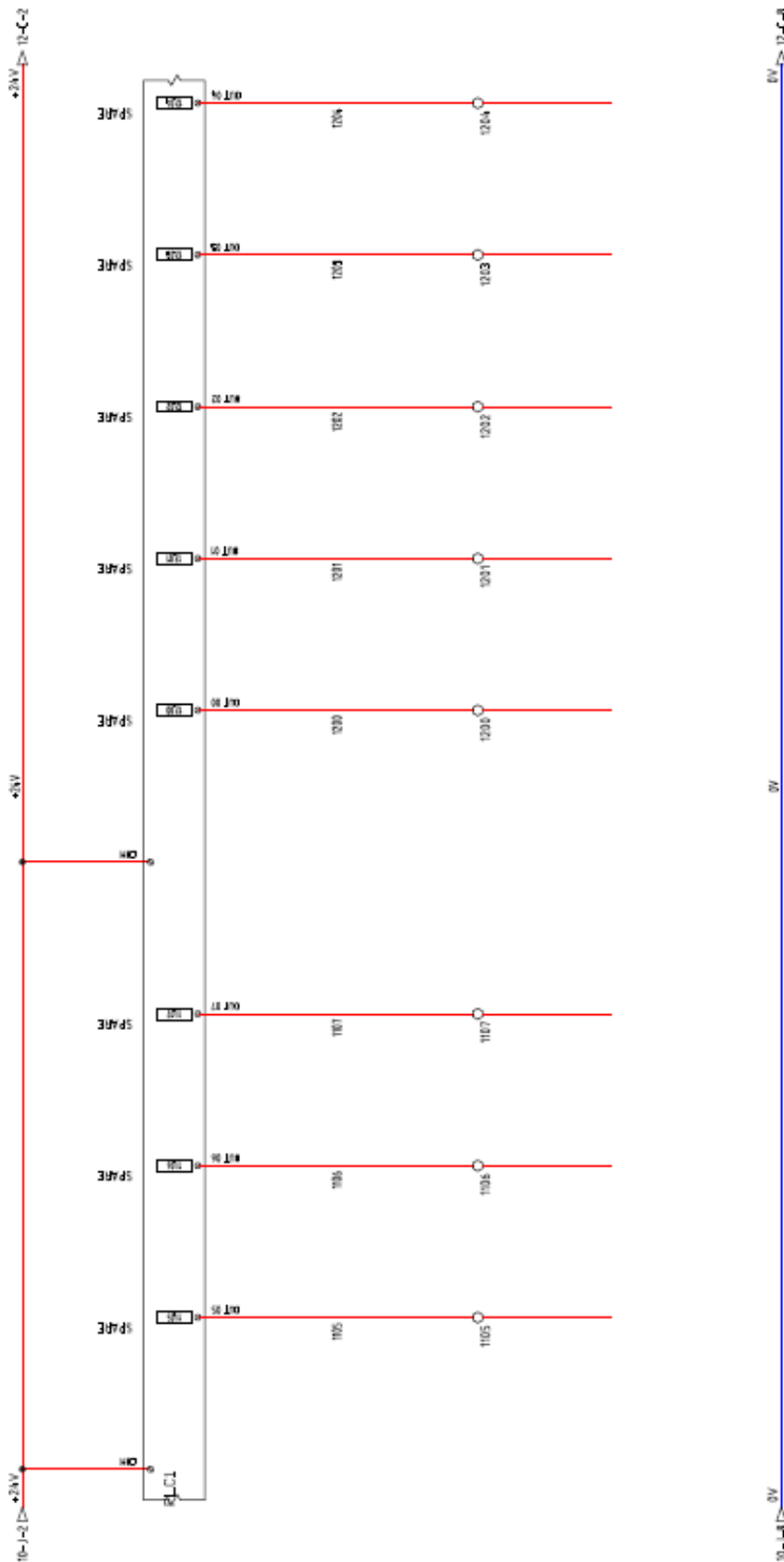

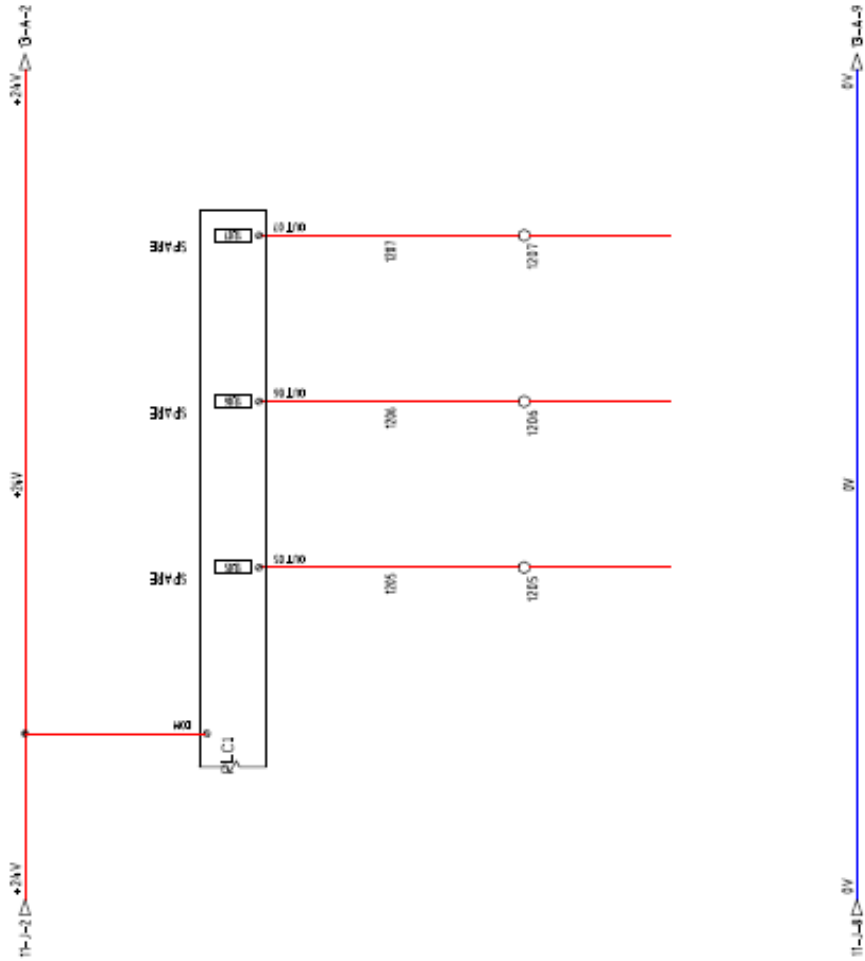

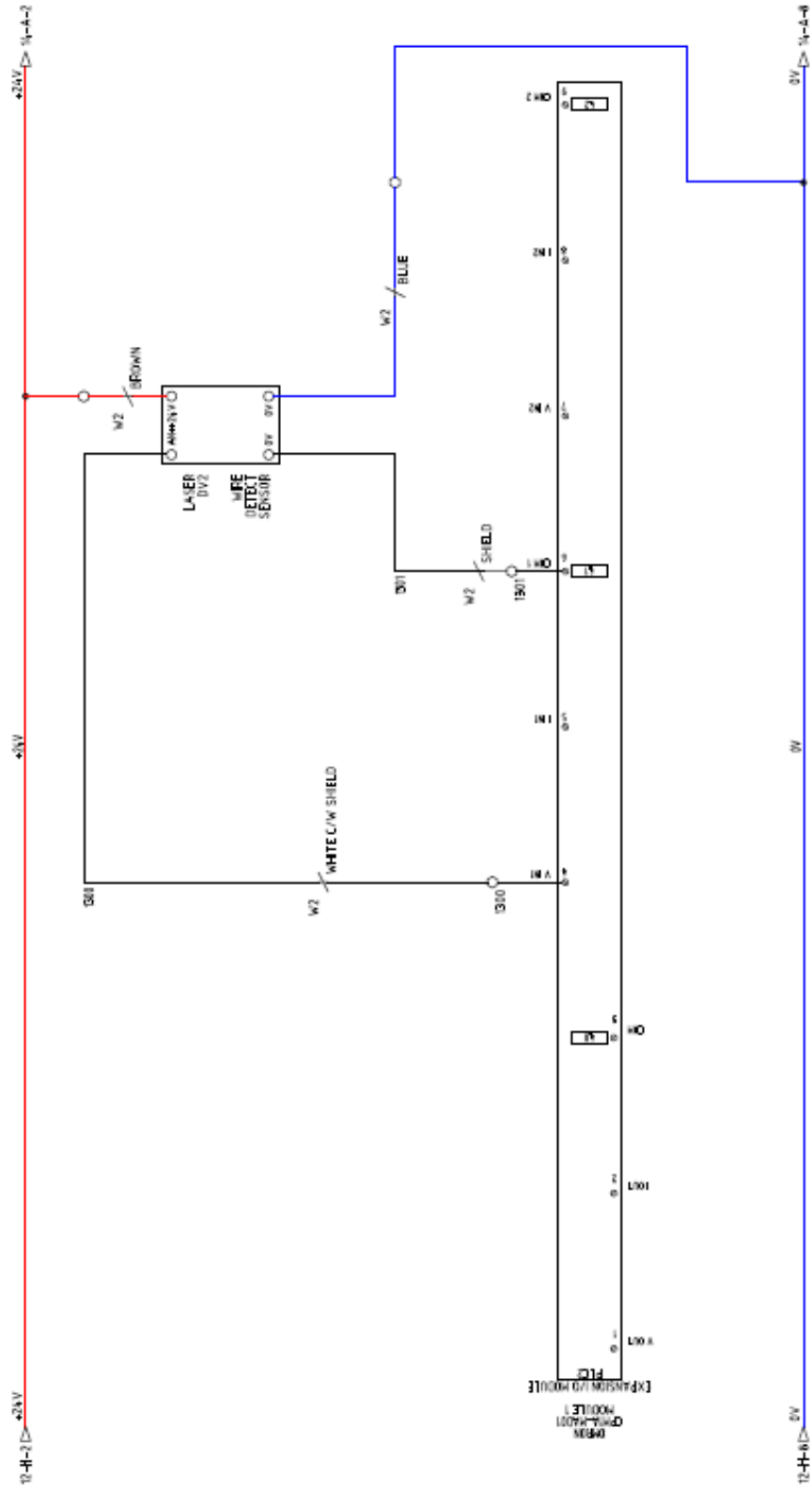

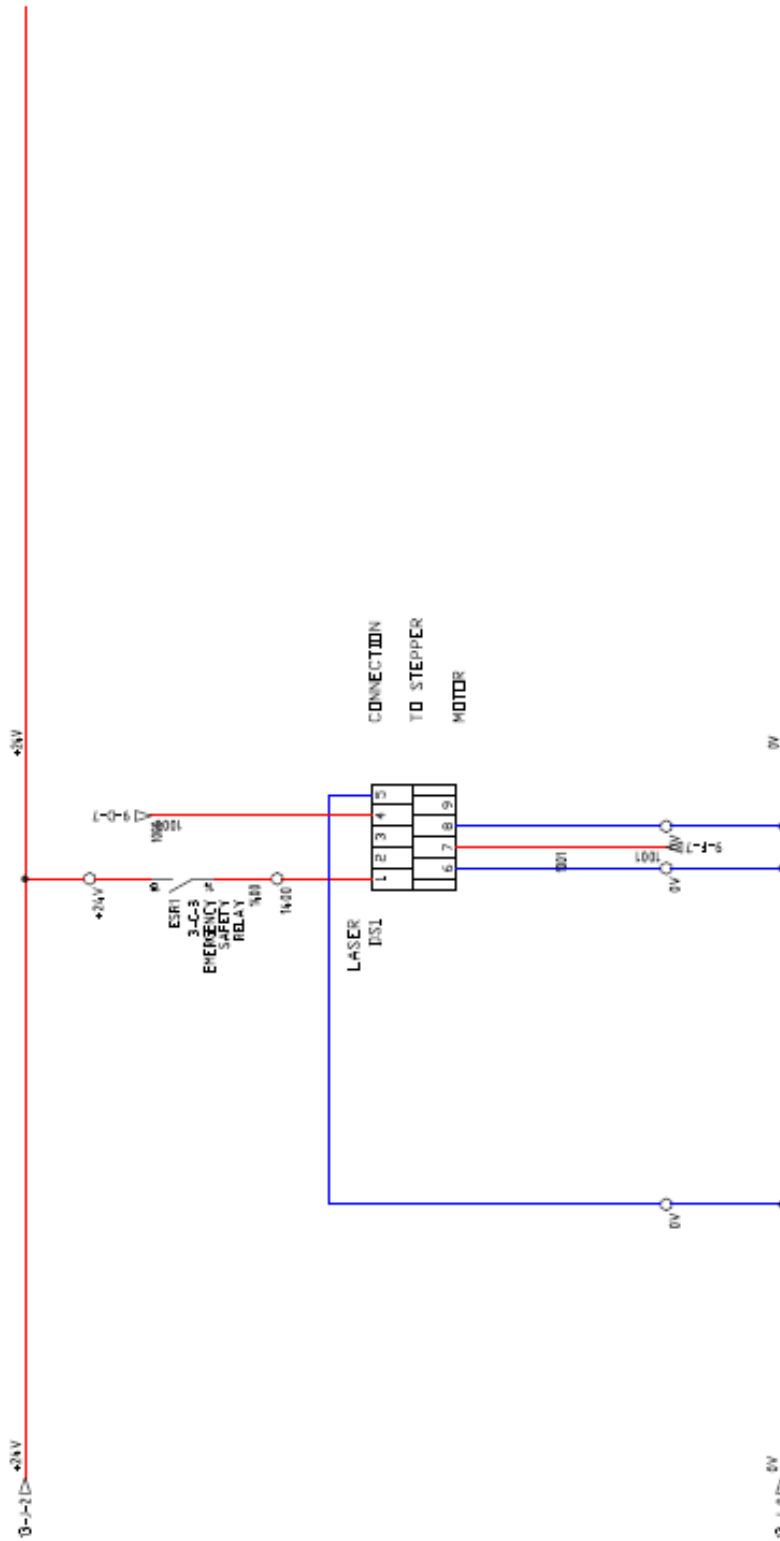

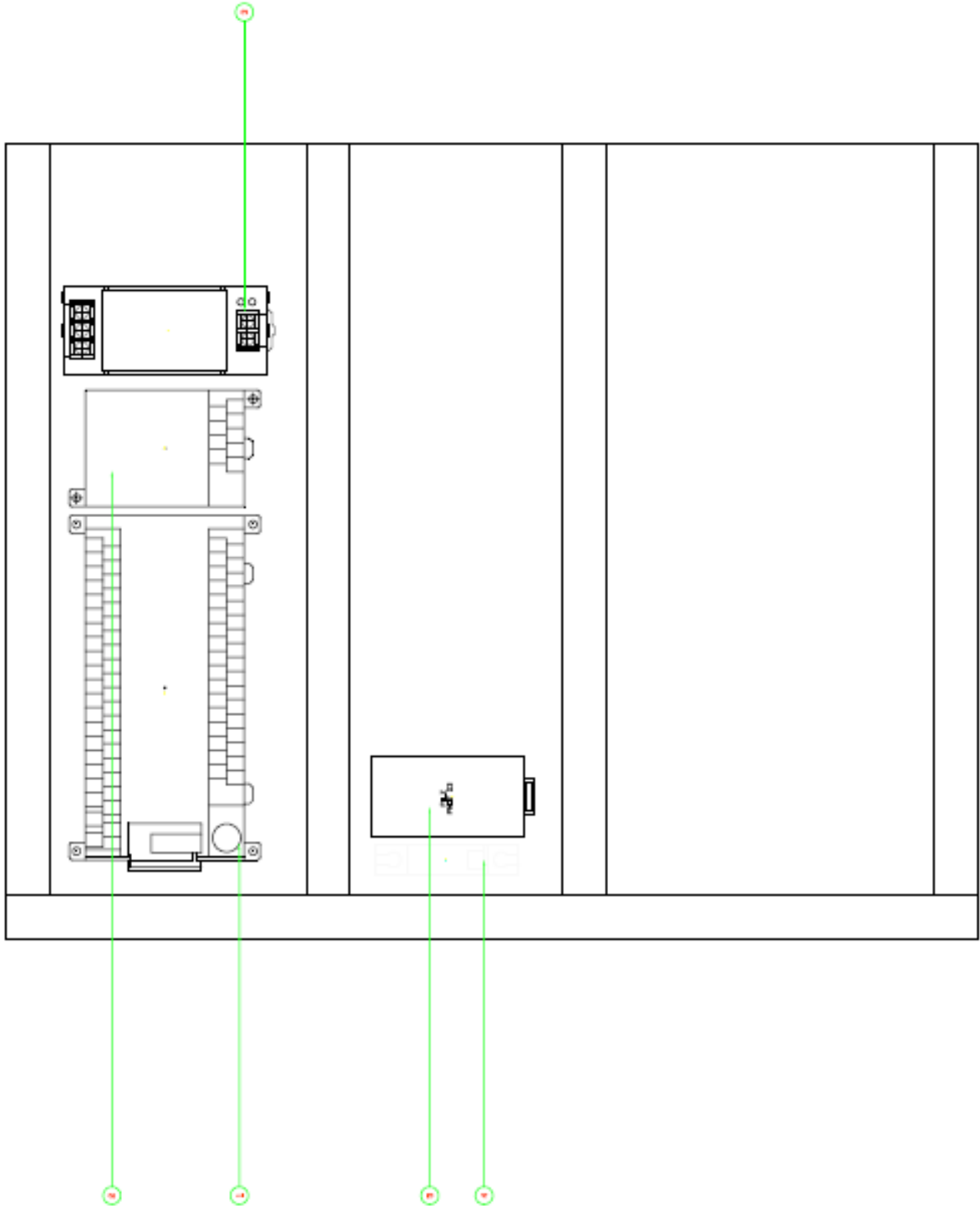

PANEL BILL OF MATERIALS

ITEM	TAGS	QTY	SUB	CATALOG	MFG	DESCRIPTION
1	PLC1	1		CPM2A-60CDT1-D	OMRON	CPM2A - CPU W/ 60 I/O POINTS CPM2A PROCESSOR 24 VDC, TRANSISTOR OUTPUTS, PNP 36 INPUT POINTS, 24 OUTPUT POINTS ATC
2	PLC2	1		CPM1A-MAD01	OMRON	CPM1A - ANALOG I/O MODULE CPM1A ANALOG COMBINATION ANALOG OUTPUT 2 INPUTS, 1 OUTPUTS ATC
3	G1	1		S8VS-12024	OMRON	POWER SUPPLY 5A 24VDC OUTPUT 110-220VAC INPUT ATC
4	Q2	1		C60HD102	MERLIN GERIN	POLE 2 AMP MCB C60H 10kA Rated trip type D IP 2A 10kA MCB CURVE D FARNELL 434-5861
5	ESR1	1		PNOZ X3 24VDC	PILZ	EMERGENCY STOP & GATE MONITORING SAFETY RELAY PILZ 774310

5.3 Pneumatic Diagrams

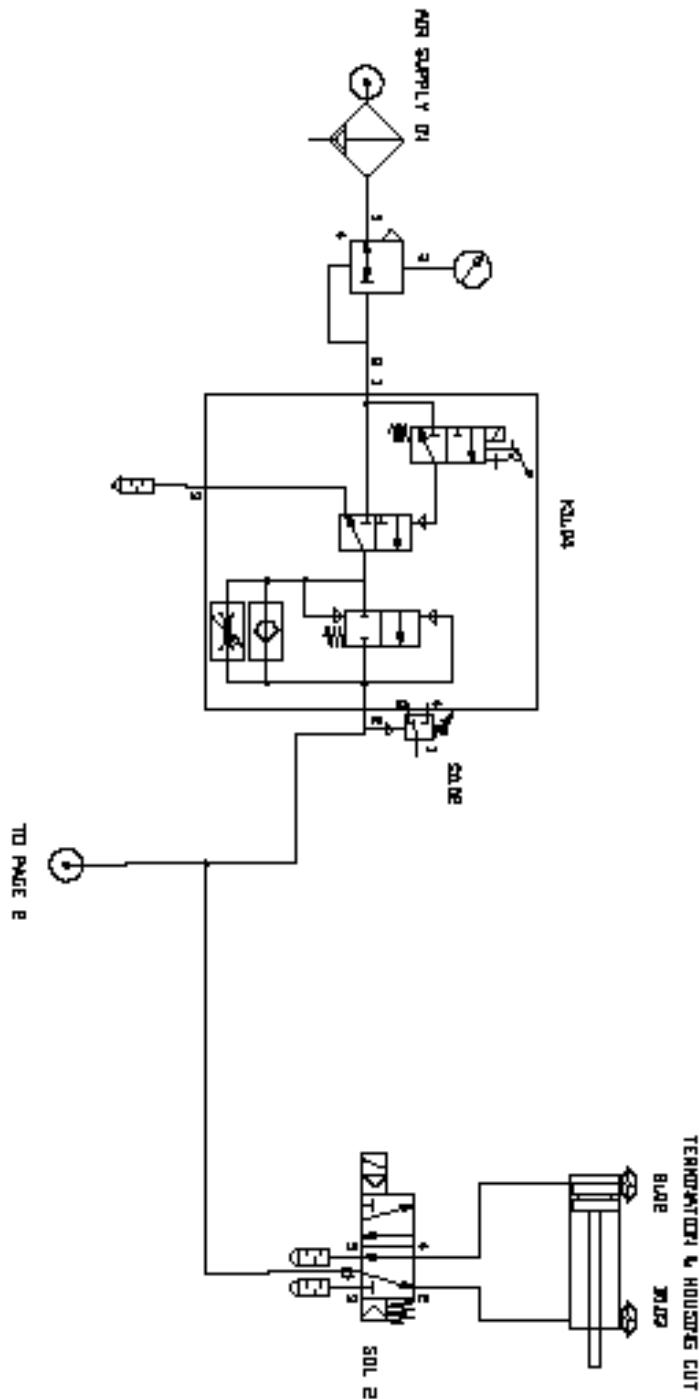

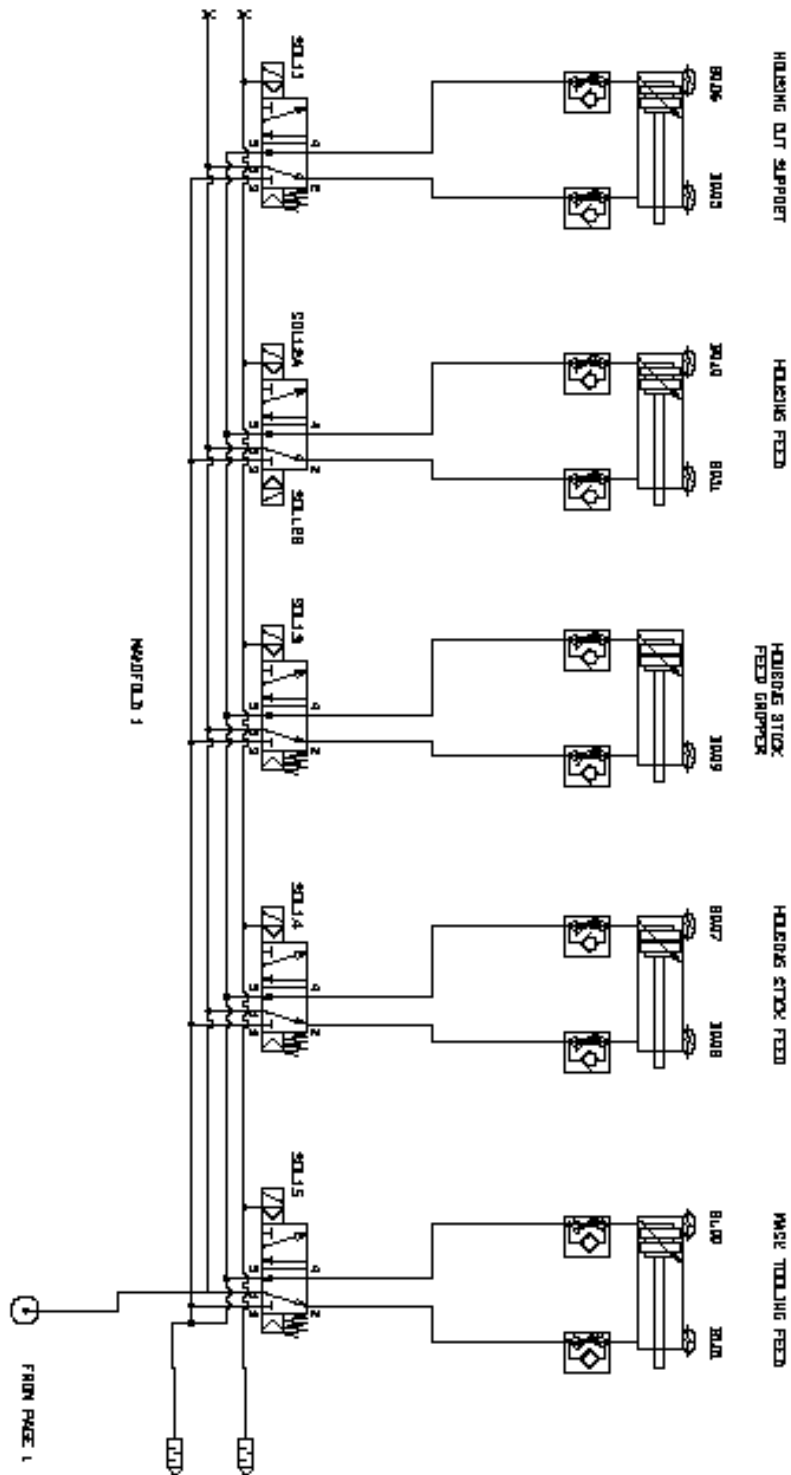

Section 6

Connector Series Chart

Products: 5.00mm (.197") Pitch Appli-Mate™ RAST 5.0 IDT Connector Assemblies 2 to 12 Circuits.

Connector Series No.	Circuit Size	Connector Assembly Order No.						
91627	2	91627-0001	91627-0002	91627-0003	91627-0004	91627-0005	91627-0006	91627-0008
		91627-0009	91627-0010	91627-0011	91627-0012	91627-0013	91627-0014	91627-0015
		91627-0016	91627-0501	91627-0502	91627-0503	91627-0504	91627-0505	91627-0506
		91627-0507	91627-0508					
	3	91627-1001	91627-1002	91627-1004	91627-1005	91627-1006	91627-1007	91627-1008
		91627-1009	91627-1010	91627-1011	91627-1012	91627-1013	91627-1014	91627-1015
		91627-1016	91627-1017	91627-1501	91627-1502	91627-1503	91627-1504	91627-1506
		91627-1507	91627-1508					
	4	91627-2001	91627-2002	91627-2003	91627-2004	91627-2005	91627-2006	91627-2007
		91627-2008	91627-2009	91627-2010	91627-2011	91627-2501	91627-2503	
	5	91627-3001	91627-3002	91627-3003	91627-3004	91627-3005	91627-3006	91627-3501
		91627-3502	91627-3503	91627-3504				
	6	91627-4001	91627-4002	91627-4003	91627-4004	91627-4005	91627-4006	91627-4007
		91627-4501	91627-4502	91627-4503				
	7	91627-5001	91627-5002	91627-5003	91627-5004	91627-5005	91627-5006	91627-5501
		91627-5502	91627-5503	91627-5504	91627-5505			
	8	91627-6001	91627-6002	91627-6501	91627-6502			
	9	91627-7001	91627-7002	91627-7003	91627-7501	91627-7502	91627-7503	91627-7504
	10	91627-8001	91627-8501					
	11	91627-9001	91627-9251					
12	91627-9501	91627-9751						
91691	2	91791-0001						
	3	91791-1001	91791-1002	91791-1004	91791-1504			
	4	91791-2001	91791-2004					
	5	91791-3001						
	6	91791-4001						
	7	91791-5001						
	8	91791-6001						
	9	91791-7001						
	10	91791-8001						
	11	91791-9001						
	12	91791-9501						

Americas Headquarters
 Lisle, Illinois 60532 U.S.A.
 1-800-78MOLEX
 amerinfo@molex.com

Far East North Headquarters
 Yamato, Kanagawa, Japan
 81-462-65-2324
 feninfo@molex.com

Far East South Headquarters
 Jurong, Singapore
 65-6-268-6868
 fesinfo@molex.com

European Headquarters
 Munich, Germany
 49-89-413092-0
 eurinfo@molex.com

Corporate Headquarters
 2222 Wellington Ct.
 Lisle, IL 60532 U.S.A.
 630-969-4550
 Fax: 630-969-1352

Visit our Web site at <http://www.molex.com>