

BILL OF MATERIALS

NO.	QTY	SUPPLIER	DESCRIPTION	PART No.	SEE NOTE
1	1	MOLEX	SHIELDED PCMCIA CONNECTOR KIT INCLUDES - LOWER & UPPER SHIELD CONTACT UNIT COVER PCB	91252-0001	
2	1	MOLEX	6 CORE CABLE SEE CABLE SPECIFICATION		2
3	1	MOLEX	OVERMOULDED GROMMET AND FERRULE		
4	1	HIROSE	SYSTEM CONNECTOR SET	MO I70-NK-7B-CV	2,3
5	1	MOLEX	LABEL		2,3

WIRING DIAGRAM : 6 CORE CABLE

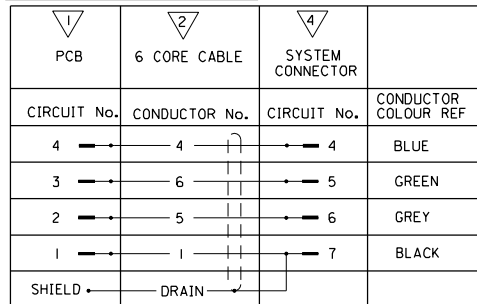

2 CABLE SPECIFICATION : 6 CORE CABLE

1. CABLE TYPE: FLAT RIBBON ROUND OTHER
 SPIRAL CABLE YES NO
 NO. OF CONDUCTORS 6

2. CABLE REQUIREMENTS :

3. CONDUCTOR SPECIFICATIONS :

CONDUCTOR #	CONDUCTOR NO.	COLOURS
1 - 6	1 - 6	1. BLACK 2. BROWN 3. RED 4. BLUE 5. GREY 6. GREEN
- MATERIAL	TINNED CU	
- A.W.G.	28	
- STRANDING QTY/GUAGE	19/40	
- TENSILE STRENGTH	N/A	
INSULATION :		
- MATERIAL	PP	
- MIN. WALL THICKNESS	0.15	
- COLOUR	SEE CABLE DIAGRAM/COLOUR CODE	
- OUTSIDE DIAMETER	0.70 ± 0.05	
DIRECTION OF LAY	S	
LENGTH OF LAY	45	
U.L. RATING	UL 1589	

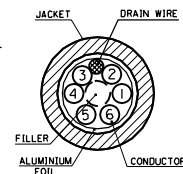

SCALE 10:1

4. FILLER :

ENOUGH TO MAKE CABLE ROUND

5. SEPARATOR :

TYPE N/A
LAY DIRECTION N/A

6. SHIELD :

FOIL TYPE ALUMINIUM FOIL
FOIL FACING SILVER SIDE IN

7. DRAIN WIRE :

GAUGE 28
STRANDING 19/40
REQUIREMENT DRAIN WIRE TO BE INSIDE SHIELD

8. SPIRAL/BRAID :

GAUGE N/A
COPPER TYPE COVERAGE

9. CABLE JACKET :

TYPE PVC
FINAL DIAMETER 3.50 ± 0.10
NOM. THICKNESS 0.50 ± 0.05
COLOUR BLACK
FINISH MATT
UL RATING UL 20276
HARDNESS 84 SHORE A
STRIPABILITY GOOD
MARKINGS N/A

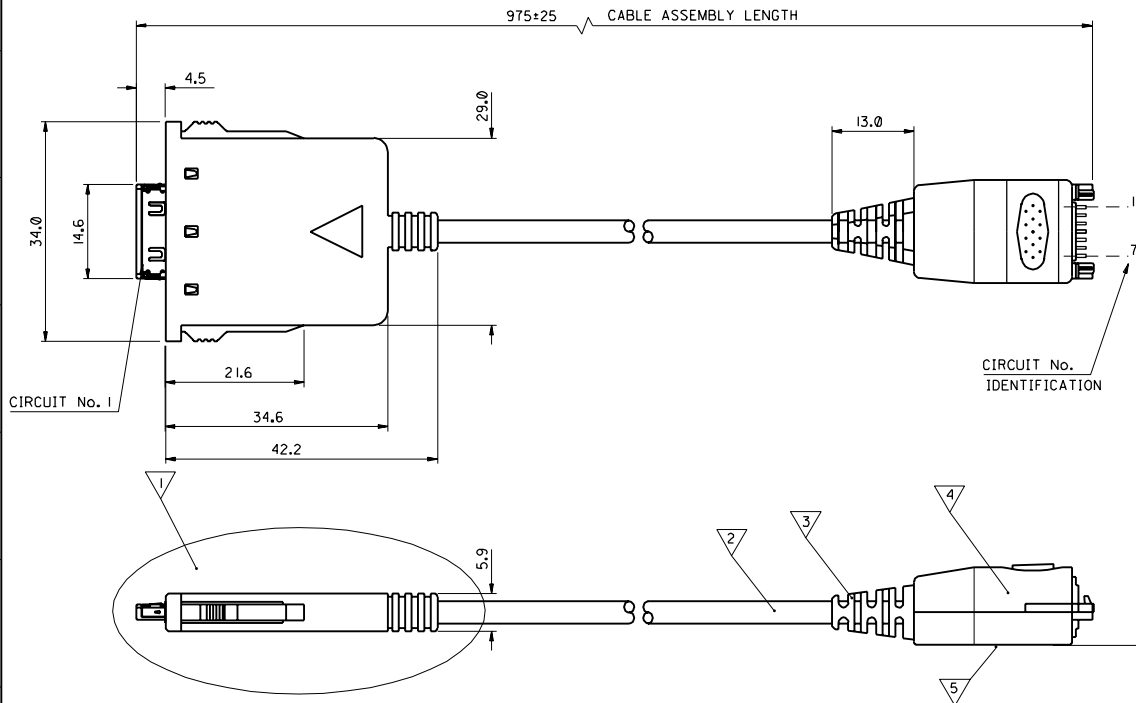

NOTES:-

- SEE PRODUCT SPECIFICATION NO. PS-99020-0070
- ONLY AVAILABLE FROM MOLEX AS PART OF A CABLE ASSEMBLY.
- SUPPLIER OR CUSTOMER APPROVED EQUIVALENT.
- ASSEMBLIES TESTED FOR SHORTS AND DISCONTINUITIES BETWEEN SYSTEM CONNECTOR AND PCB.
- PACKAGING: PARTS TO BE PACKED IN BAGS.

ORIGINAL ISSUE ECN E'0241 97/05/07 DR	REVISIONS	DIMENSIONS SHOWN (METRIC) INCH UNLESS OTHERWISE SPECIFIED TOLERANCES IN MILLIMETERS INCH (METRIC) 3 PLACE # ± 2 PLACE # ± 1 PLACE # ± 0.20 DIMENSIONS WHERE APPLICABLE MUST REMAIN WITHIN DIMENSIONS	DRWG BY MC	DRWG'D BY	APPR'D BY	SCALE 2:1
A 1	LTR	DESIGN DIMENSION (MM) (IN) (PRIMARY) <input type="checkbox"/> IN. EQUIVALENT DIMENSION (SECONDARY) <input type="checkbox"/> MM <input type="checkbox"/> IN.				

REVISE ONLY ON CAD SYSTEM		SH	REV.
CAD/CAM FILE NAME SPOKING DCH		THIS DRAWING CONTAINS INFORMATION THAT IS PROPRIETARY TO MOLEX INC. & SHOULD NOT BE USED WITHOUT WRITTEN PERMISSION	
TITLE DLH-6 DATA CABLE ASSEMBLY			
MOLEX EUROPE		SHEET NO. DATE 10F1 96/11/26	
PART NO. 92601-0006	DWG NO. SDA-92601-0006	SIZE C	

PART NO. 92601-0006
DWG NO. SDA-92601-0006