

INA129-EP Precision, Low Power Instrumentation Amplifiers

1 Features

- Low Offset Voltage
- Low Input Bias Current
- High CMR: 95 dB (Typical)
- Inputs Protected to ± 40 V
- Wide Supply Range: ± 2.25 V to ± 18 V
- Low Quiescent Current: 2 mA (Typical)

2 Applications

- Bridge Amplifier
- Thermocouple Amplifier
- RTD Sensor Amplifier
- Medical Instrumentation
- Data Acquisition
- Supports Extreme Temperature Applications:
 - Controlled Baseline
 - One Assembly and Test Site
 - One Fabrication Site
 - Available in Military (-55°C to $+125^{\circ}\text{C}$) Temperature Range ⁽¹⁾
 - Extended Product Life Cycle
 - Extended Product-Change Notification
 - Product Traceability

(1) Custom temperature ranges available

3 Description

The INA129-EP device is a low power, general-purpose instrumentation amplifier offering excellent accuracy. The versatile 3-op amp design and small size make the device ideal for a wide range of applications. Current-feedback input circuitry provides wide bandwidth even at high gain (200 kHz at $G = 100$).

A single external resistor sets any gain from 1 to 10,000. The INA129-EP provides an industry-standard gain equation; the INA129-EP gain equation is compatible with the AD620.

The INA129-EP device is laser trimmed for very low offset voltage, drift, and high common-mode rejection (113 dB at $G \geq 100$). It operates with power supplies as low as ± 2.25 V, and quiescent current is only 750 μA —ideal for battery operated systems. Internal input protection can withstand up to ± 40 V without damage.

The INA129-EP is available in a 8-Pin SOIC surface-mount package specified for the -55°C to 125°C temperature range.

Device Information⁽¹⁾

PART NUMBER	PACKAGE	BODY SIZE (NOM)
INA129-EP	SOIC (8)	4.90 mm \times 3.91 mm

(1) For all available packages, see the orderable addendum at the end of the data sheet.

Simplified Schematic

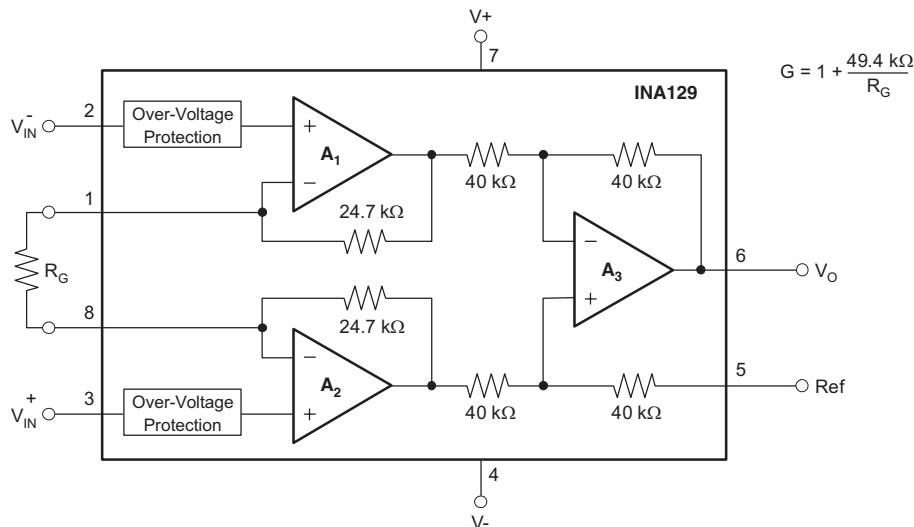

Table of Contents

1 Features	1	7.4 Device Functional Modes.....	12
2 Applications	1	8 Application and Implementation	13
3 Description	1	8.1 Application Information.....	13
4 Revision History	2	8.2 Typical Application	13
5 Pin Configuration and Functions	3	9 Power Supply Recommendations	17
6 Specifications	5	9.1 Low Voltage Operation	17
6.1 Absolute Maximum Ratings	5	10 Layout	18
6.2 ESD Ratings.....	5	10.1 Layout Guidelines	18
6.3 Recommended Operating Conditions.....	5	10.2 Layout Example	18
6.4 Thermal Information	5	11 Device and Documentation Support	19
6.5 Electrical Characteristics.....	6	11.1 Community Resources.....	19
6.6 Typical Characteristics	8	11.2 Trademarks	19
7 Detailed Description	11	11.3 Electrostatic Discharge Caution.....	19
7.1 Overview	11	11.4 Glossary	19
7.2 Functional Block Diagram	11	12 Mechanical, Packaging, and Orderable	
7.3 Feature Description.....	11	Information	19

4 Revision History

NOTE: Page numbers for previous revisions may differ from page numbers in the current version.

Changes from Original (December 2009) to Revision A	Page
• Added <i>ESD Ratings</i> table, <i>Feature Description</i> section, <i>Device Functional Modes</i> , <i>Application and Implementation</i> section, <i>Power Supply Recommendations</i> section, <i>Layout</i> section, <i>Device and Documentation Support</i> section, and <i>Mechanical, Packaging, and Orderable Information</i> section	1
• Removed junction-to-ambient thermal resistance value for 8-pin DIP package, and updated SOIC package thermal information.	5

5 Pin Configuration and Functions

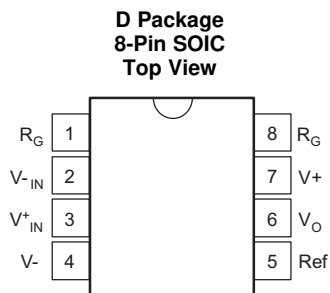

Pin Functions

PIN		I/O	DESCRIPTION
NAME	NO.		
Ref	5	I	Output voltage reference
RG	1, 8	O	Gain resistor connection
V+	7	Power	Positive power supply voltage from 2.25 V to 18 V
V-	4	Power	Negative power supply voltage from -2.25 V to -18 V
V+IN	3	I	Non-inverting input voltage
V-IN	2	I	Inverting input voltage
VO	6	O	Output voltage

Bare Die Information

DIE THICKNESS	BACKSIDE FINISH	BACKSIDE POTENTIAL	BOND PAD METALLIZATION COMPOSITION
15 mils	Silicon with backgrind	GND	Al-Si-Cu (0.5%)

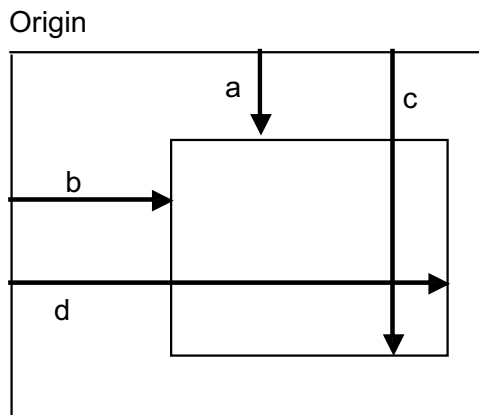

INA129-EP

SBOS508A – DECEMBER 2009 – REVISED DECEMBER 2015

www.ti.com

Bond Pad Coordinates in Mils

DESCRIPTION	PAD NUMBER	a	b	c	d
NC	1	-57.4	-31.1	-53.3	-27
V _{-IN}	2	-9.85	-31.4	-5.75	-27.3
V _{+IN}	3	25.05	-31.4	29.15	-27.3
V ₋	4	56.2	-34.3	60.3	-30.2
Ref	5	53.75	-17.6	57.85	-11
V _O	6	50.35	27.8	56.95	31.9
V ₊	7	7.75	30.2	11.85	34.3
NC	8	-57.4	28.4	-53.3	32.5
R _G ⁽¹⁾	9	-57.4	13.4	-53.3	20
R _G ⁽¹⁾	10	-57.5	2.7	-53.4	9.3
R _G ⁽¹⁾	11	-57.5	-7.9	-53.4	-1.3
R _G ⁽¹⁾	12	-57.4	-18.6	-53.3	-12

- (1) Pads 9 and 10 must both be bonded to a common point and correspond to package pin 8. Pads 11 and 12 must both be bonded to a common point and correspond to package pin 1.

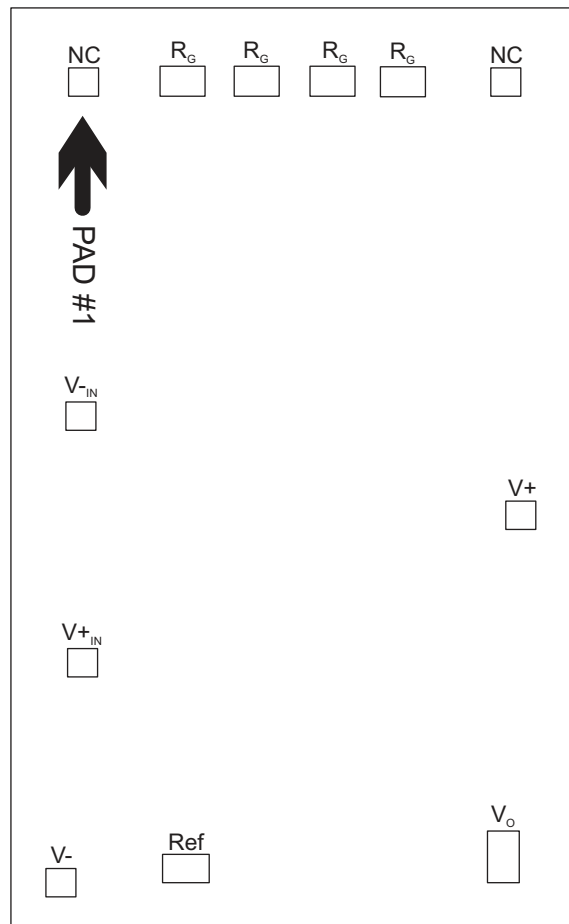

6 Specifications

6.1 Absolute Maximum Ratings

over operating free-air temperature range (unless otherwise noted) ⁽¹⁾

	MIN	MAX	UNIT
V _S Supply voltage		±18	V
Analog input voltage		±40	V
Output short-circuit (to ground)	Continuous		
T _A Operating temperature	–55	125	°C
T _J Junction temperature		150	°C
Lead temperature (soldering, 10s)		300	°C
T _{stg} Storage temperature	–55	125	°C

(1) Stresses above these ratings may cause permanent damage. Exposure to absolute maximum conditions for extended periods may degrade device reliability. These are stress ratings only, and functional operation of the device at these or any other conditions beyond those specified is not implied.

6.2 ESD Ratings

	VALUE	UNIT
V _(ESD) Electrostatic discharge	Human body model (HBM), per ANSI/ESDA/JEDEC JS-001, all pins ⁽¹⁾	±4000
	Charged device model (CDM), per JEDEC specification JESD22-C101, all pins ⁽²⁾	±200

(1) JEDEC document JEP155 states that 500-V HBM allows safe manufacturing with a standard ESD control process.

(2) JEDEC document JEP157 states that 250-V CDM allows safe manufacturing with a standard ESD control process.

6.3 Recommended Operating Conditions

over operating free-air temperature range (unless otherwise noted)

	MIN	NOM	MAX	UNIT
V power supply	±2.25	±15	±18	V
Input common-mode voltage range for V _O = 0	V – 2 V		V + –2 V	
T _A operating temperature INA129-EP	–55		125	°C

6.4 Thermal Information

THERMAL METRIC ⁽¹⁾	INA129-EP	UNIT
	D (SOIC)	
	8 PINS	
R _{θJA} Junction-to-ambient thermal resistance	110	°C/W
R _{θJC(top)} Junction-to-case (top) thermal resistance	57	°C/W
R _{θJB} Junction-to-board thermal resistance	54	°C/W
Ψ _{JT} Junction-to-top characterization parameter	11	°C/W
Ψ _{JB} Junction-to-board characterization parameter	53	°C/W

(1) For more information about traditional and new thermal metrics, see the *IC Package Thermal Metrics* application report, [SPRA953](#).

INA129-EP

SBOS508A – DECEMBER 2009 – REVISED DECEMBER 2015

www.ti.com

6.5 Electrical Characteristics

At $T_A = 25^\circ\text{C}$, $V_S = \pm 15\text{ V}$, $R_L = 10\text{ k}\Omega$ (unless otherwise noted)

PARAMETER	TEST CONDITIONS	$T_A = 25^\circ\text{C}$			$T_A = 25^\circ\text{C}$			UNIT
		MIN	TYP	MAX	MIN	TYP	MAX	
INPUT								
Offset Voltage, RTI								
Initial	$T_A = 25^\circ\text{C}$			± 100 $\pm 800/\text{G}$				μV
	Overtemperature					± 150 $\pm 2050/\text{G}$		
vs power supply	$T_A = 25^\circ\text{C}$, $V_S = \pm 2.25\text{ V}$ to $\pm 18\text{ V}$			± 1.6 $\pm 175/\text{G}$				$\mu\text{V}/\text{V}$
	Overtemperature					± 1.8 $\pm 175/\text{G}$		
Long-term stability			± 1	$\pm 3/\text{G}$				$\mu\text{V}/\text{mo}$
Impedance, differential				$10^{10} \parallel 2$				$\Omega \parallel \text{pF}$
Common mode				$10^{11} \parallel 9$				$\Omega \parallel \text{pF}$
Common mode voltage range ⁽¹⁾	$V_O = 0\text{ V}$		$(V^+) - \frac{1}{2}$	$(V^+) - 1.4$				V
			$(V^-) + \frac{1}{2}$	$(V^-) + 1.7$				V
Safe input voltage						± 40		V
Common-mode rejection	$V_{\text{CM}} = \pm 13\text{ V}$, $\Delta R_S = 1\text{ k}\Omega$	G = 1	75	86				dB
		Overtemperature				67		
		G = 10	93	106				
		Overtemperature				84		
		G = 100	113	125				
		Overtemperature				98		
		G = 1000	113	130				
		Overtemperature				98		
CURRENT								
Bias current				± 2	± 8			nA
	Overtemperature					± 16		
Offset Current				± 1	± 8			nA
	Overtemperature					± 16		
NOISE								
Noise voltage, RTI	G = 1000, $R_S = 0\ \Omega$	f = 10 Hz		10				$\text{nV}/\sqrt{\text{Hz}}$
		f = 100 Hz		8				
		f = 1 kHz		8				
		$f_B = 0.1\text{ Hz}$ to 10 Hz			0.2			μVpp
Noise current	G = 1000, $R_S = 0\ \Omega$	f = 10 Hz		0.9			$\text{pA}/\sqrt{\text{Hz}}$	
		f = 1 kHz		0.3				
		$f_B = 0.1\text{ Hz}$ to 10 Hz			30			pA_{pp}
GAIN								
Gain equation				$1 + \frac{49.4}{\text{k}\Omega/R_G}$				V/V
Range of gain				1	10000			V/V

(1) Input common-mode range varies with output voltage — see [Typical Characteristics](#).

Electrical Characteristics (continued)

 At $T_A = 25^\circ\text{C}$, $V_S = \pm 15\text{ V}$, $R_L = 10\text{ k}\Omega$ (unless otherwise noted)

PARAMETER	TEST CONDITIONS	$T_A = 25^\circ\text{C}$			$T_A = 25^\circ\text{C}$			UNIT
		MIN	TYP	MAX	MIN	TYP	MAX	
Gain error	G = 1		±0.05%	±0.1%				
	Overtemperature						±0.15%	
	G = 10		±0.02%	±0.5%				
	Overtemperature						±0.65%	
	G = 100		±0.05%	±0.65%				
	Overtemperature						±1.1%	
Gain vs temperature ⁽²⁾	G = 1		±1	±10				ppm/°C
49.4-k Ω resistance ⁽²⁾⁽³⁾			±25	±100				ppm/°C
Nonlinearity	$V_O = \pm 13.6\text{ V}$, G = 1		±0.0001	±0.0018				% of FSR
	Overtemperature						±0.0035	
	G = 10		±0.0003	±0.0035				
	Overtemperature						±0.0055	
	G = 100		±0.0005	±0.0035				
	Overtemperature						±0.0055	
	G = 1000		±0.001	See ⁽⁴⁾				
OUTPUT								
Voltage	Positive	$R_L = 10\text{ k}\Omega$	$(V^+) - 1.4$	$(V^+) - 0.9$				V
	Negative	$R_L = 10\text{ k}\Omega$	$(V^-) + 1.4$	$(V^-) + 0.8$				
Load capacitance stability			1000					pF
Short-circuit current			+6/-15					mA
FREQUENCY RESPONSE								
Bandwidth, -3 dB	G = 1		1300					kHz
	G = 10		700					
	G = 100		200					
	G = 1000		20					
Slew rate	$V_O = \pm 10\text{ V}$, G = 10		4					V/ μs
Settling time, 0.01%	G = 1		7					μs
	G = 10		7					
	G = 100		9					
	G = 1000		80					
Overload recovery	50% overdrive		4					μs
POWER SUPPLY								
Voltage range			±2.25	±15	±18			V
Current, total	$V_{IN} = 0\text{ V}$		±700	±750				μA
	Overtemperature						±1200	
TEMPERATURE RANGE								
Specification			-55		125			°C
Operating			-55		125			°C

⁽²⁾ Specified by wafer test.

⁽³⁾ Temperature coefficient of the 49.4-k Ω term in the gain equation.

⁽⁴⁾ Nonlinearity measurements in G = 1000 are dominated by noise. Typical nonlinearity is ±0.001%.

INA129-EP

SBOS508A – DECEMBER 2009 – REVISED DECEMBER 2015

www.ti.com

6.6 Typical Characteristics

At $T_A = 25^\circ\text{C}$, $V_S = \pm 15\text{ V}$, unless otherwise noted.

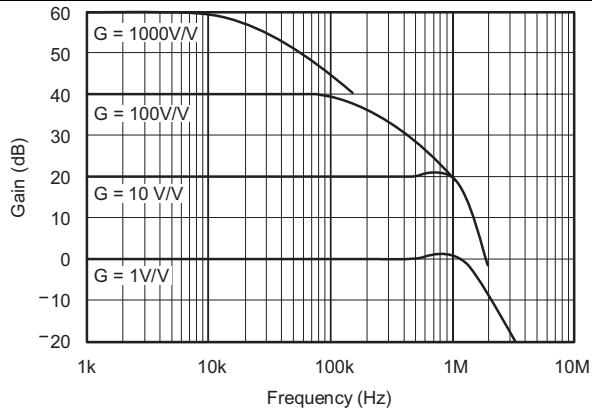

Figure 1. Gain vs Frequency

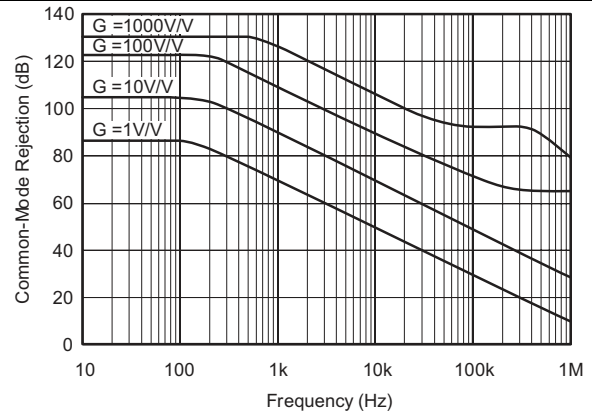

Figure 2. Common-Mode Rejection vs Frequency

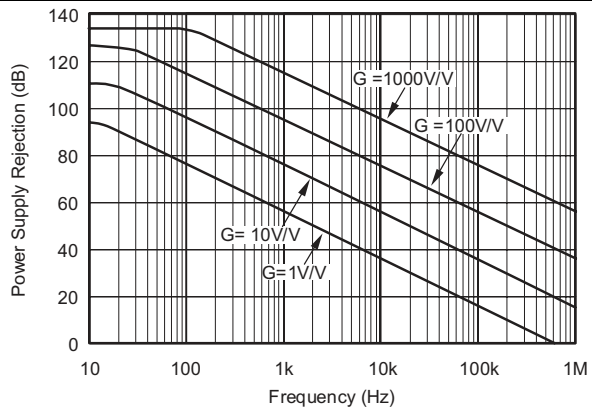

Figure 3. Positive Power-Supply Rejection vs Frequency

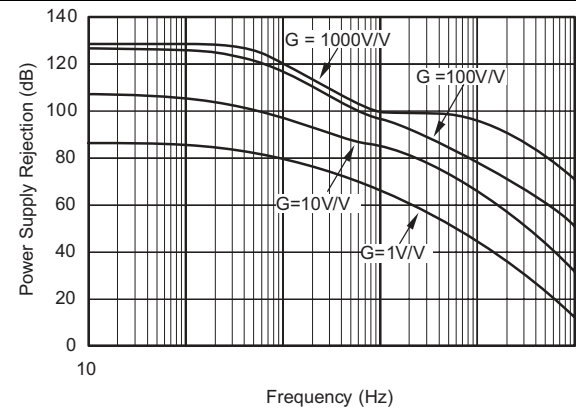

Figure 4. Negative Power-Supply Rejection vs Frequency

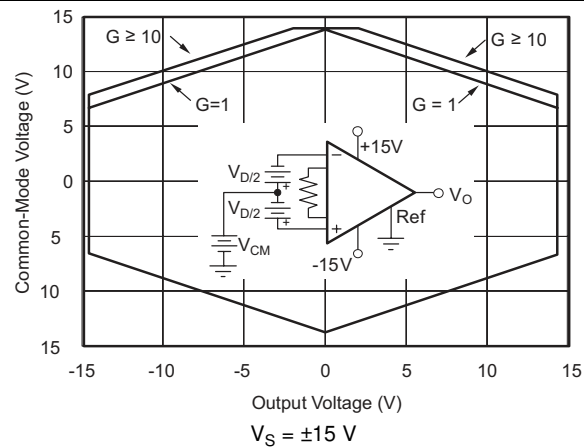

Figure 5. Input Common-Mode Range vs Output Voltage

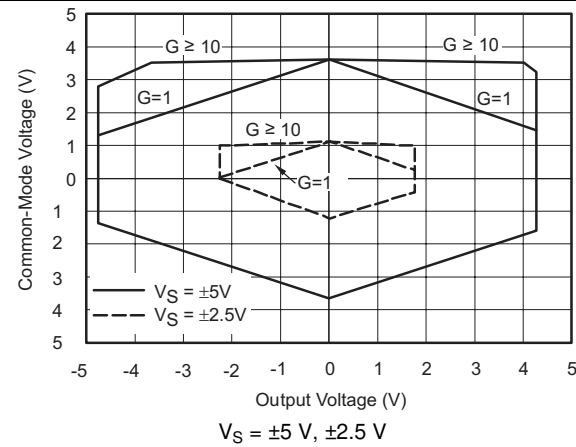
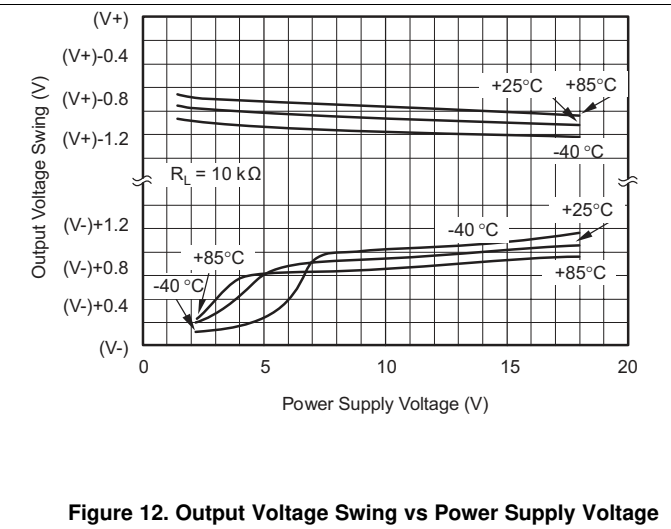
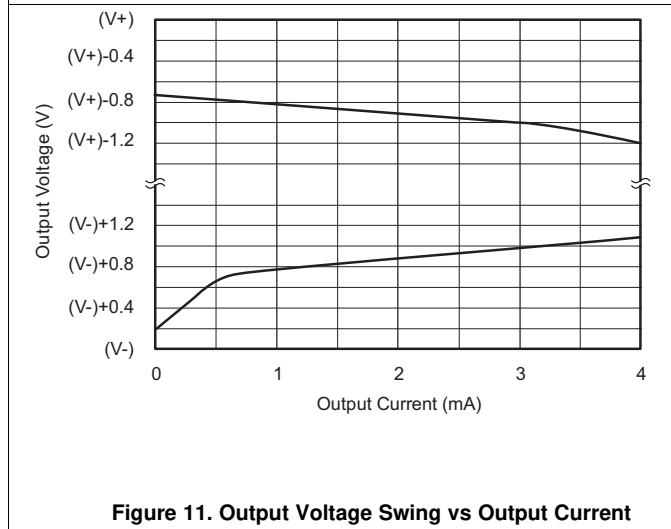
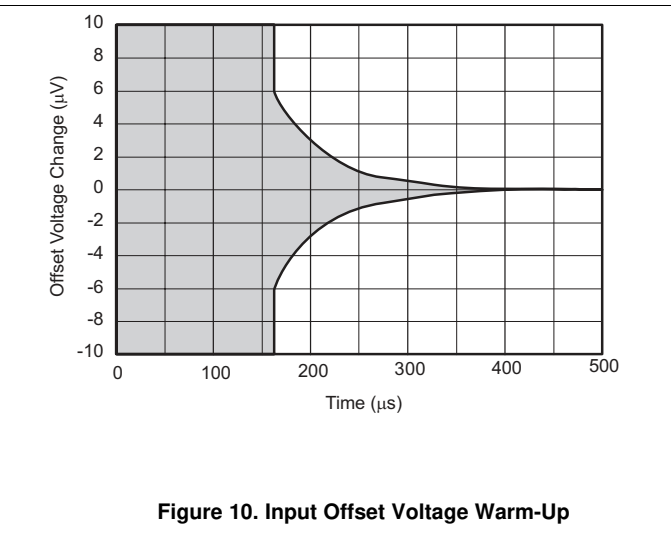
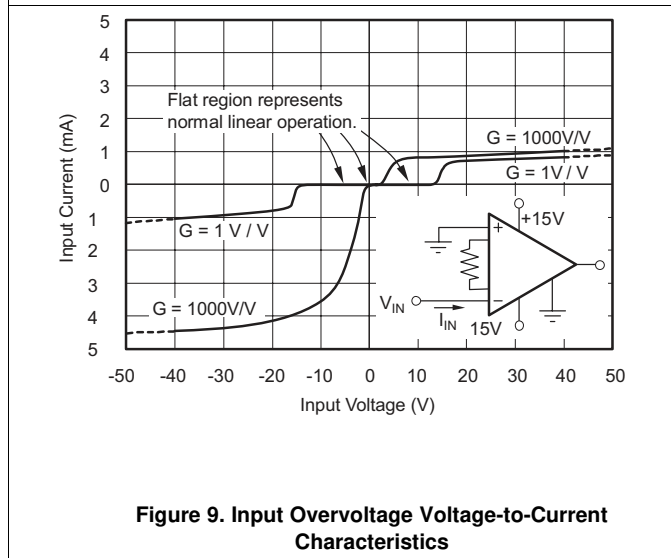
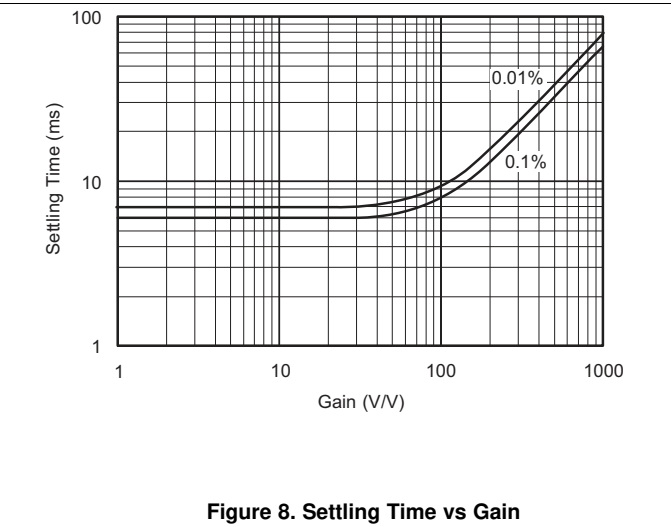
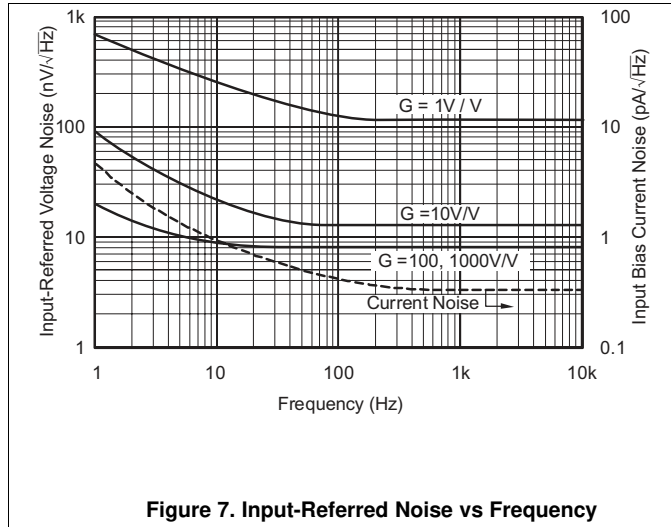

Figure 6. Input Common-Mode Range vs Output Voltage

Typical Characteristics (continued)

At $T_A = 25^\circ\text{C}$, $V_S = \pm 15\text{ V}$, unless otherwise noted.



Typical Characteristics (continued)

At $T_A = 25^\circ\text{C}$, $V_S = \pm 15\text{ V}$, unless otherwise noted.

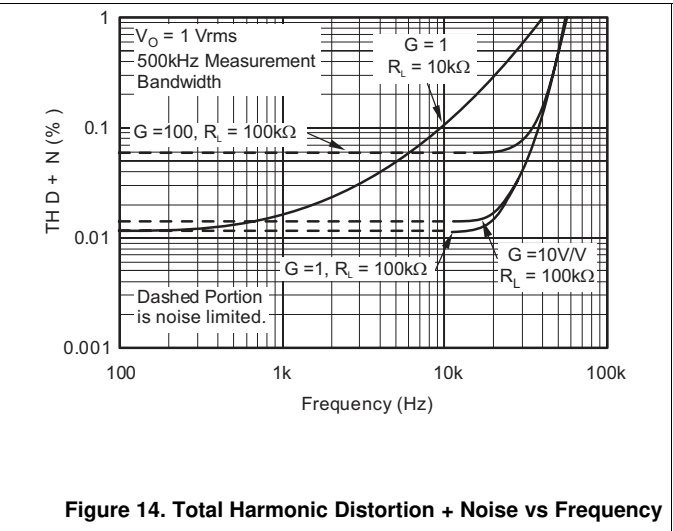
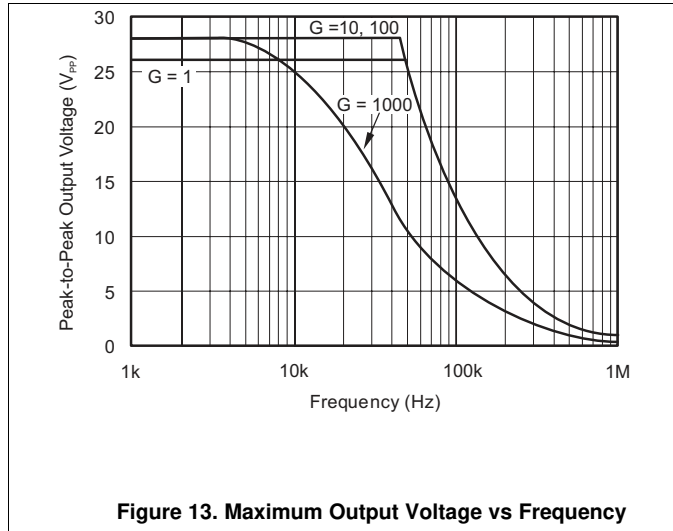

7 Detailed Description

7.1 Overview

The INA129-EP instrumentation amplifier is a type of differential amplifier that has been outfitted with input protection circuit and input buffer amplifiers, which eliminate the need for input impedance matching and make the amplifier particularly suitable for use in measurement and test equipment. Additional characteristics of the INA129-EP include a very low DC offset, low drift, low noise, very high open-loop gain, very high common-mode rejection ratio, and very high input impedances. The INA129-EP is used where great accuracy and stability of the circuit both short and long-term are required.

7.2 Functional Block Diagram

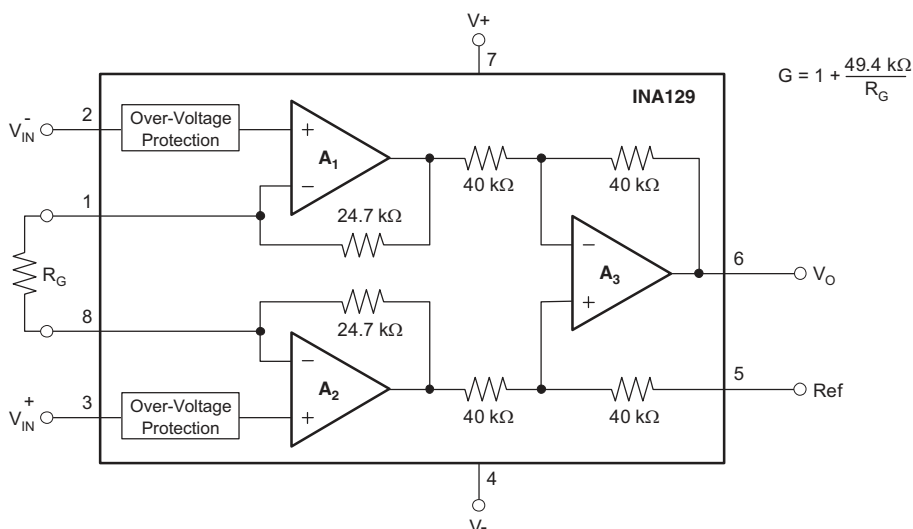

7.3 Feature Description

The INA129-EP device is a low power, general-purpose instrumentation amplifier that offers excellent accuracy. The versatile three-operational-amplifier design and small size make the amplifier ideal for a wide range of applications. Current-feedback input circuitry provides wide bandwidth, even at high gain. A single external resistor sets any gain from 1 to 10,000. The INA129-EP device is laser trimmed for very low offset voltage (50 μV) and high common-mode rejection (93 dB at $G \geq 100$). This device operates with power supplies as low as $\pm 2.25 \text{ V}$, and quiescent current of 2 mA, typically. The internal input protection can withstand up to $\pm 40 \text{ V}$ without damage.

7.4 Device Functional Modes

A single external resistor sets the any gain from 1 to 10000. TI INA129-EP provides an industry standard gain equation, as highlighted in [Figure 16](#).

7.4.1 Noise Performance

The INA129-EP provides very low noise in most applications. Low frequency noise is approximately 0.2 μ VPP measured from 0.1 Hz to 10 Hz ($G \geq 100$). This provides dramatically improved noise when compared to state-of-the-art chopper-stabilized amplifiers.

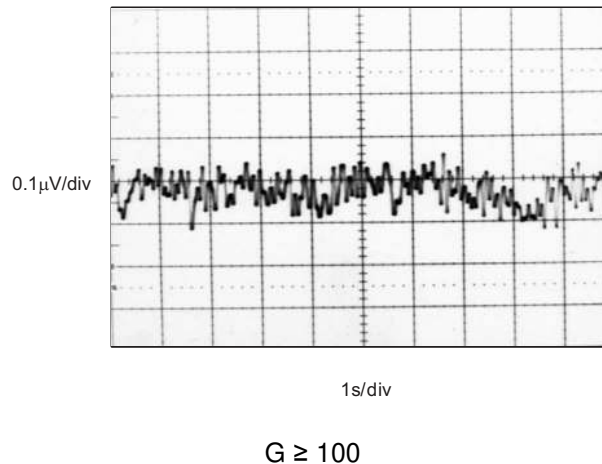

Figure 15. 0.1-Hz to 10-Hz Input-Referred Voltage Noise

7.4.2 Input Common-Mode Range

The linear input voltage range of the input circuitry of the INA129-EP is from approximately 1.4 V below the positive supply voltage to 1.7 V above the negative supply. As a differential input voltage causes the output voltage increase, however, the linear input range will be limited by the output voltage swing of amplifiers A1 and A2. So the linear common-mode input range is related to the output voltage of the complete amplifier. This behavior also depends on supply voltage (see [Figure 5](#) and [Figure 6](#)).

Input-overload can produce an output voltage that appears normal. For example, if an input overload condition drives both input amplifiers to their positive output swing limit, the difference voltage measured by the output amplifier will be near zero. The output of A3 will be near 0 V even though both inputs are overloaded.

8 Application and Implementation

NOTE

Information in the following applications sections is not part of the TI component specification, and TI does not warrant its accuracy or completeness. TI's customers are responsible for determining suitability of components for their purposes. Customers should validate and test their design implementation to confirm system functionality.

8.1 Application Information

The INA129-EP device measures small differential voltage with high common-mode voltage developed between the non-inverting and inverting input. The high-input voltage protection circuit in conjunction with high input impedance make the INA129-EP suitable for a wide range of applications. The ability to set the reference pin to adjust the functionality of the output signal offers additional flexibility that is practical for multiple configurations.

8.2 Typical Application

Figure 16 shows the basic connections required for operation of the INA129-EP. Applications with noisy or high impedance power supplies may require decoupling capacitors close to the device pins as shown.

The output is referred to the output reference (Ref) terminal which is normally grounded. This must be a low-impedance connection to assure good common-mode rejection. A resistance of 8 Ω in series with the Ref pin will cause a typical device to degrade to approximately 80 dB CMR (G = 1).

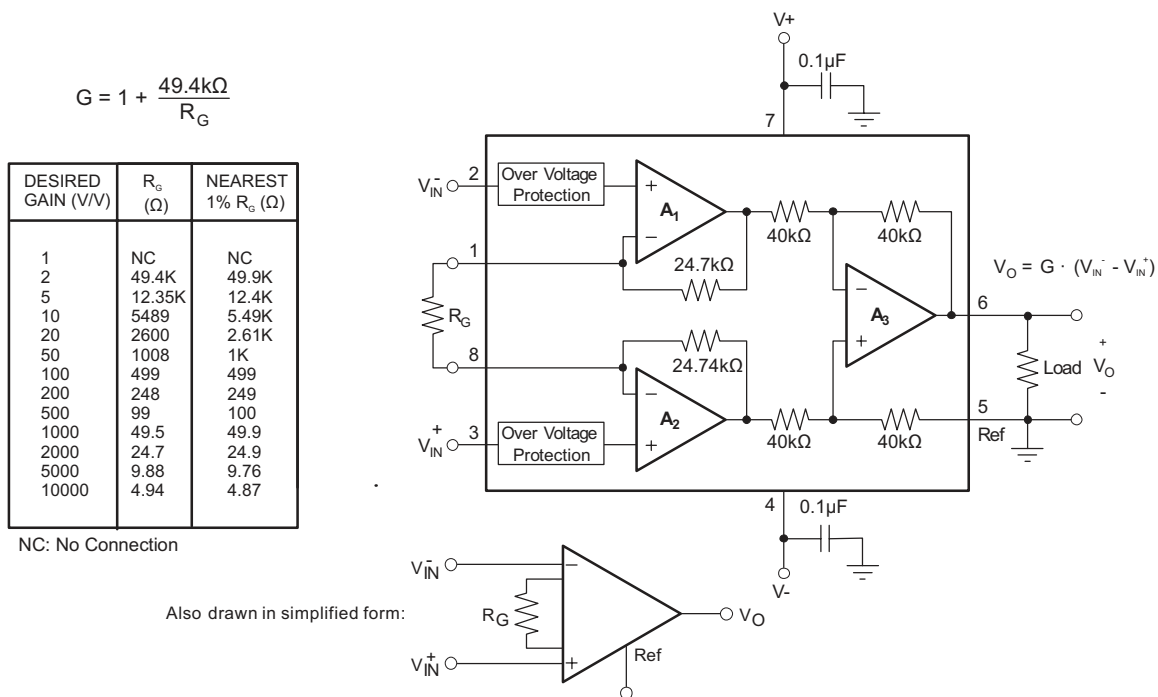

Figure 16. Basic Connections

8.2.1 Design Requirements

The device can be configured to monitor the input differential voltage when the gain of the input signal is set by the external resistor R_G. The output signal references to the REF pin. The most common application is where the output is referenced to ground when no input signal is present by connecting the REF pin to ground, as Figure 16 shows. When the input signal increases, the output voltage at the OUT pin increases, too.

Typical Application (continued)

8.2.2 Detailed Design Procedure

8.2.2.1 Setting the Gain

Gain is set by connecting a single external resistor, R_G , between pins 1 and 8.

$$G = 1 + \frac{49.4 \text{ k}\Omega}{R_G} \quad (1)$$

Commonly used gains and resistor values are shown in [Figure 16](#).

The 49.9-k Ω term in [Equation 1](#) comes from the sum of the two internal feedback resistors of A1 and A2. These on-chip metal film resistors are laser trimmed to accurate absolute values. The accuracy and temperature coefficient of these internal resistors are included in the gain accuracy and drift specifications of the INA129-EP.

The stability and temperature drift of the external gain setting resistor, R_G , also affects gain. R_G 's contribution to gain accuracy and drift can be directly inferred from [Equation 1](#). Low resistor values required for high gain can make wiring resistance important. Sockets add to the wiring resistance which will contribute additional gain error (possibly an unstable gain error) in gains of approximately 100 or greater.

8.2.2.2 Dynamic Performance

[Figure 1](#) shows that, despite its low quiescent current, the INA129-EP achieves wide bandwidth, even at high gain. This is due to the current-feedback topology of the input stage circuitry. Settling time also remains excellent at high gain.

8.2.2.3 Offset Trimming

The INA129-EP is laser trimmed for low offset voltage and offset voltage drift. Most applications require no external offset adjustment. [Figure 17](#) shows an optional circuit for trimming the output offset voltage. The voltage applied to Ref terminal is summed with the output. The operational amplifier buffer provides low impedance at the Ref terminal to preserve good common-mode rejection.

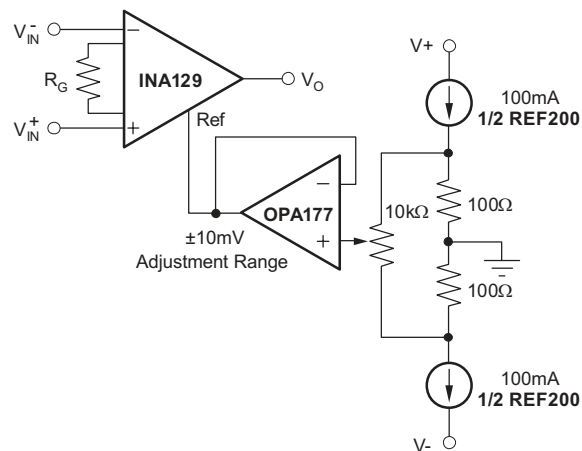

Figure 17. Optional Trimming of Output Offset Voltage

8.2.2.4 Input Bias Current Return Path

The input impedance of the INA129-EP is extremely high (approximately $10^{10} \Omega$). However, a path must be provided for the input bias current of both inputs. This input bias current is approximately $\pm 2 \text{ nA}$. High input impedance means that this input bias current changes very little with varying input voltage.

Input circuitry must provide a path for this input bias current for proper operation. [Figure 18](#) shows various provisions for an input bias current path. Without a bias current path, the inputs will float to a potential which exceeds the common-mode range, and the input amplifiers will saturate.

Typical Application (continued)

If the differential source resistance is low, the bias current return path can be connected to one input (see the thermocouple example in Figure 18). With higher source impedance, using two equal resistors provides a balanced input with possible advantages of lower input offset voltage due to bias current and better high-frequency common-mode rejection.

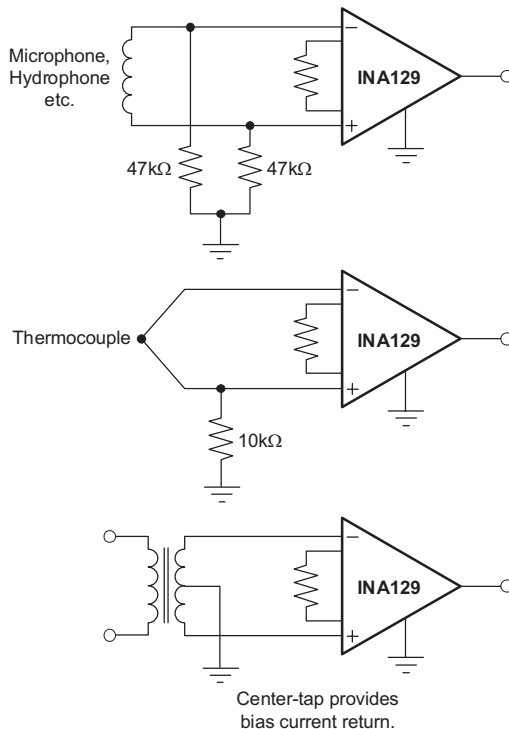
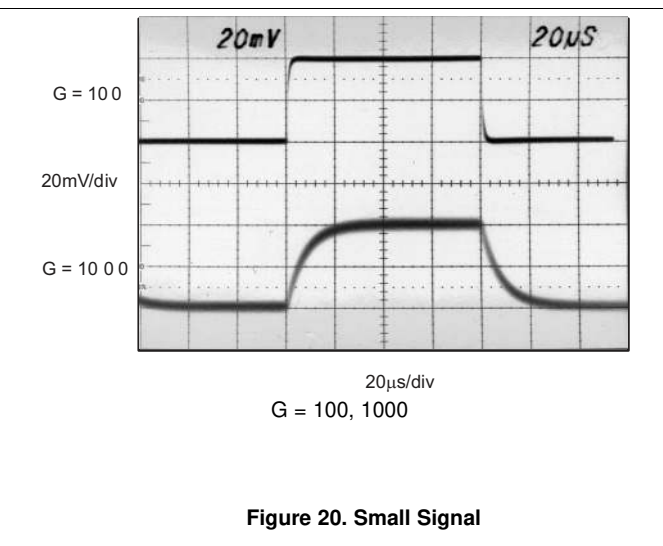
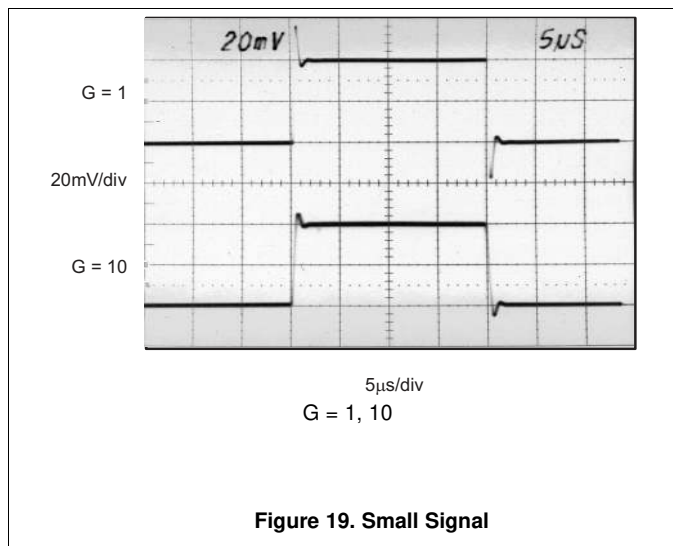

Figure 18. Providing an Input Common-Mode Current Path

8.2.3 Application Curves



Typical Application (continued)

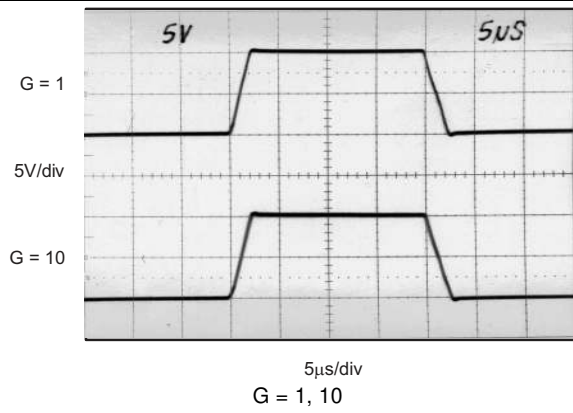

Figure 21. Large Signal

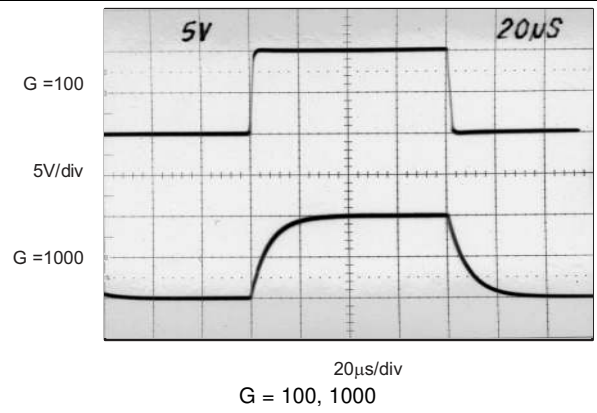

Figure 22. Large Signal

9 Power Supply Recommendations

The minimum power supply voltage for INA129-EP is ± 2.25 V and the maximum power supply voltage is ± 18 V. This minimum and maximum range covers a wide range of power supplies; but for optimum performance, ± 15 V is recommended. TI recommends adding a bypass capacitor at the input to compensate for the layout and power supply source impedance.

9.1 Low Voltage Operation

The INA129-EP can be operated on power supplies as low as ± 2.25 V. Performance remains excellent with power supplies ranging from ± 2.25 V to ± 18 V. Most parameters vary only slightly throughout this supply voltage range.

Operation at very low supply voltage requires careful attention to assure that the input voltages remain within their linear range. Voltage swing requirements of internal nodes limit the input common-mode range with low power supply voltage. Figure 5 and Figure 6 show the range of linear operation for ± 15 V, ± 5 V, and ± 2.5 V supplies.

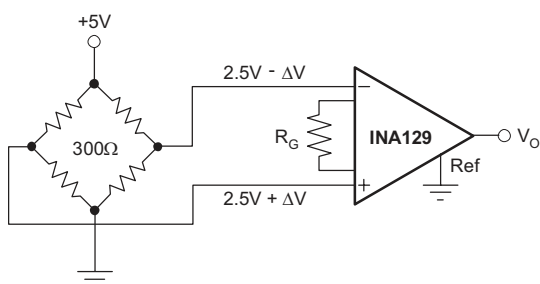

Figure 23. Bridge Amplifier

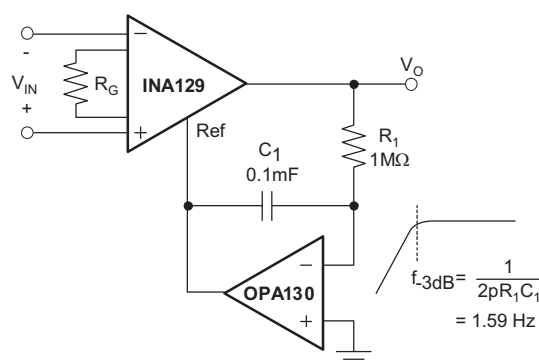
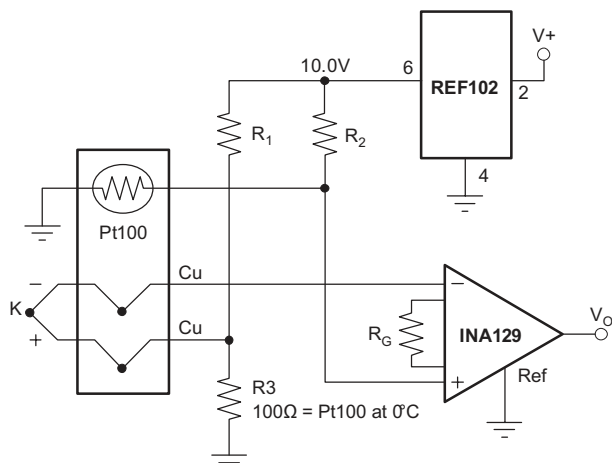
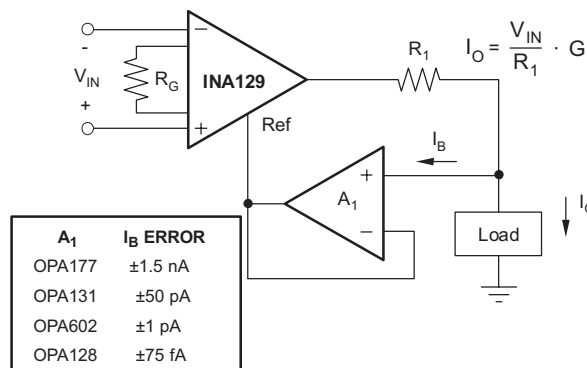

Figure 24. AC-Coupled Instrumentation Amplifier



ISA TYPE	MATERIAL	SEEBECK COEFFICIENT (mV/°C)	R ₁ , R ₂
E	+Chromel	58.5	66.5kΩ
	-Constantan		
J	+Iron	50.2	76.8kΩ
	-Constantan		
K	+Chromel	39.4	97.6kΩ
	-Alumel		
T	+Copper	38	102kΩ
	-Constantan		

Figure 25. Thermocouple Amplifier With RTD Cold-Junction Compensation



A ₁	I _B ERROR
OPA177	±1.5 nA
OPA131	±50 pA
OPA602	±1 pA
OPA128	±75 fA

Figure 26. Differential Voltage to Current Converter

Low Voltage Operation (continued)

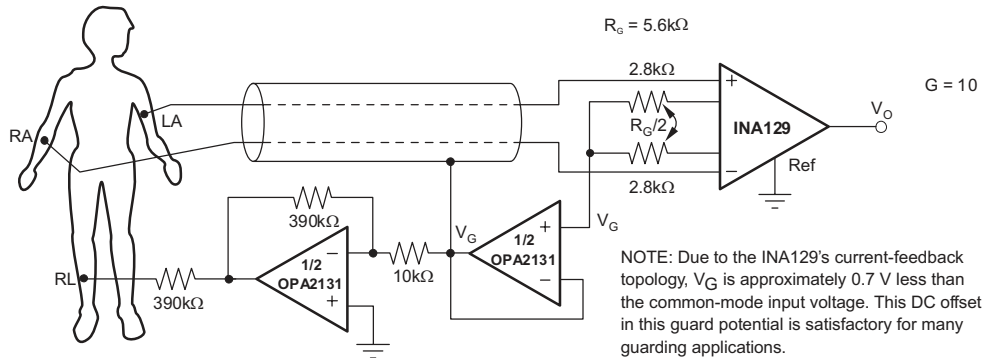

Figure 27. ECG Amplifier With Right-Leg Drive

10 Layout

10.1 Layout Guidelines

Place the power-supply bypass capacitor as closely as possible to the supply and ground pins. The recommended value of this bypass capacitor is 0.1 μF to 1 μF . If necessary, additional decoupling capacitance can be added to compensate for noisy or high-impedance power supplies. These decoupling capacitors must be placed between the power supply and INA129-EP device.

The gain resistor must be placed close to pin 1 and pin 8. This placement limits the layout loop and minimizes any noise coupling into the part.

10.2 Layout Example

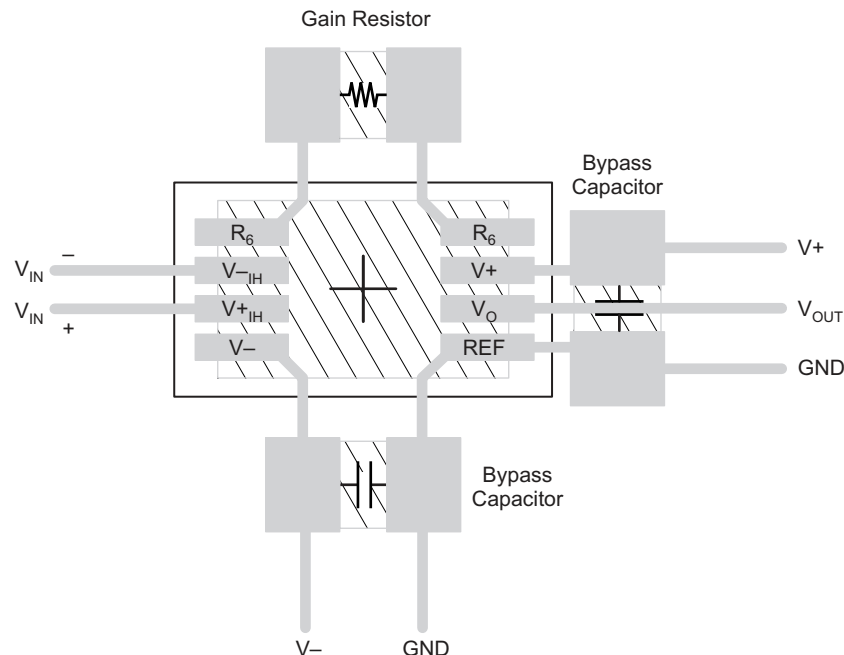

Figure 28. Recommended Layout

11 Device and Documentation Support

11.1 Community Resources

The following links connect to TI community resources. Linked contents are provided "AS IS" by the respective contributors. They do not constitute TI specifications and do not necessarily reflect TI's views; see TI's [Terms of Use](#).

TI E2E™ Online Community *TI's Engineer-to-Engineer (E2E) Community*. Created to foster collaboration among engineers. At e2e.ti.com, you can ask questions, share knowledge, explore ideas and help solve problems with fellow engineers.

Design Support *TI's Design Support* Quickly find helpful E2E forums along with design support tools and contact information for technical support.

11.2 Trademarks

E2E is a trademark of Texas Instruments.
All other trademarks are the property of their respective owners.

11.3 Electrostatic Discharge Caution



These devices have limited built-in ESD protection. The leads should be shorted together or the device placed in conductive foam during storage or handling to prevent electrostatic damage to the MOS gates.

11.4 Glossary



[SLYZ022](#) — *TI Glossary*.

This glossary lists and explains terms, acronyms, and definitions.

12 Mechanical, Packaging, and Orderable Information

The following pages include mechanical, packaging, and orderable information. This information is the most current data available for the designated devices. This data is subject to change without notice and revision of this document. For browser-based versions of this data sheet, refer to the left-hand navigation.

PACKAGING INFORMATION

Orderable Device	Status (1)	Package Type	Package Drawing	Pins	Package Qty	Eco Plan (2)	Lead finish/ Ball material (6)	MSL Peak Temp (3)	Op Temp (°C)	Device Marking (4/5)	Samples
INA129MDREP	ACTIVE	SOIC	D	8	2500	RoHS & Green	NIPDAU	Level-3-260C-168 HR	-55 to 125	129EP	
V62/10605-01XE	ACTIVE	SOIC	D	8	2500	RoHS & Green	NIPDAU	Level-3-260C-168 HR	-55 to 125	129EP	

(1) The marketing status values are defined as follows:

ACTIVE: Product device recommended for new designs.

LIFEBUY: TI has announced that the device will be discontinued, and a lifetime-buy period is in effect.

NRND: Not recommended for new designs. Device is in production to support existing customers, but TI does not recommend using this part in a new design.

PREVIEW: Device has been announced but is not in production. Samples may or may not be available.

OBSELETE: TI has discontinued the production of the device.

(2) **RoHS:** TI defines "RoHS" to mean semiconductor products that are compliant with the current EU RoHS requirements for all 10 RoHS substances, including the requirement that RoHS substance do not exceed 0.1% by weight in homogeneous materials. Where designed to be soldered at high temperatures, "RoHS" products are suitable for use in specified lead-free processes. TI may reference these types of products as "Pb-Free".

RoHS Exempt: TI defines "RoHS Exempt" to mean products that contain lead but are compliant with EU RoHS pursuant to a specific EU RoHS exemption.

Green: TI defines "Green" to mean the content of Chlorine (Cl) and Bromine (Br) based flame retardants meet JS709B low halogen requirements of <=1000ppm threshold. Antimony trioxide based flame retardants must also meet the <=1000ppm threshold requirement.

(3) MSL, Peak Temp. - The Moisture Sensitivity Level rating according to the JEDEC industry standard classifications, and peak solder temperature.

(4) There may be additional marking, which relates to the logo, the lot trace code information, or the environmental category on the device.

(5) Multiple Device Markings will be inside parentheses. Only one Device Marking contained in parentheses and separated by a "-" will appear on a device. If a line is indented then it is a continuation of the previous line and the two combined represent the entire Device Marking for that device.

(6) Lead finish/Ball material - Orderable Devices may have multiple material finish options. Finish options are separated by a vertical ruled line. Lead finish/Ball material values may wrap to two lines if the finish value exceeds the maximum column width.

Important Information and Disclaimer:The information provided on this page represents TI's knowledge and belief as of the date that it is provided. TI bases its knowledge and belief on information provided by third parties, and makes no representation or warranty as to the accuracy of such information. Efforts are underway to better integrate information from third parties. TI has taken and continues to take reasonable steps to provide representative and accurate information but may not have conducted destructive testing or chemical analysis on incoming materials and chemicals. TI and TI suppliers consider certain information to be proprietary, and thus CAS numbers and other limited information may not be available for release.

In no event shall TI's liability arising out of such information exceed the total purchase price of the TI part(s) at issue in this document sold by TI to Customer on an annual basis.

OTHER QUALIFIED VERSIONS OF INA129-EP :

- Catalog: [INA129](#)

NOTE: Qualified Version Definitions:

- Catalog - TI's standard catalog product

TAPE AND REEL INFORMATION

QUADRANT ASSIGNMENTS FOR PIN 1 ORIENTATION IN TAPE

*All dimensions are nominal

Device	Package Type	Package Drawing	Pins	SPQ	Reel Diameter (mm)	Reel Width W1 (mm)	A0 (mm)	B0 (mm)	K0 (mm)	P1 (mm)	W (mm)	Pin1 Quadrant
INA129MDREP	SOIC	D	8	2500	330.0	12.4	6.4	5.2	2.1	8.0	12.0	Q1

TAPE AND REEL BOX DIMENSIONS

*All dimensions are nominal

Device	Package Type	Package Drawing	Pins	SPQ	Length (mm)	Width (mm)	Height (mm)
INA129MDREP	SOIC	D	8	2500	356.0	356.0	35.0

D0008A



PACKAGE OUTLINE

SOIC - 1.75 mm max height

SMALL OUTLINE INTEGRATED CIRCUIT

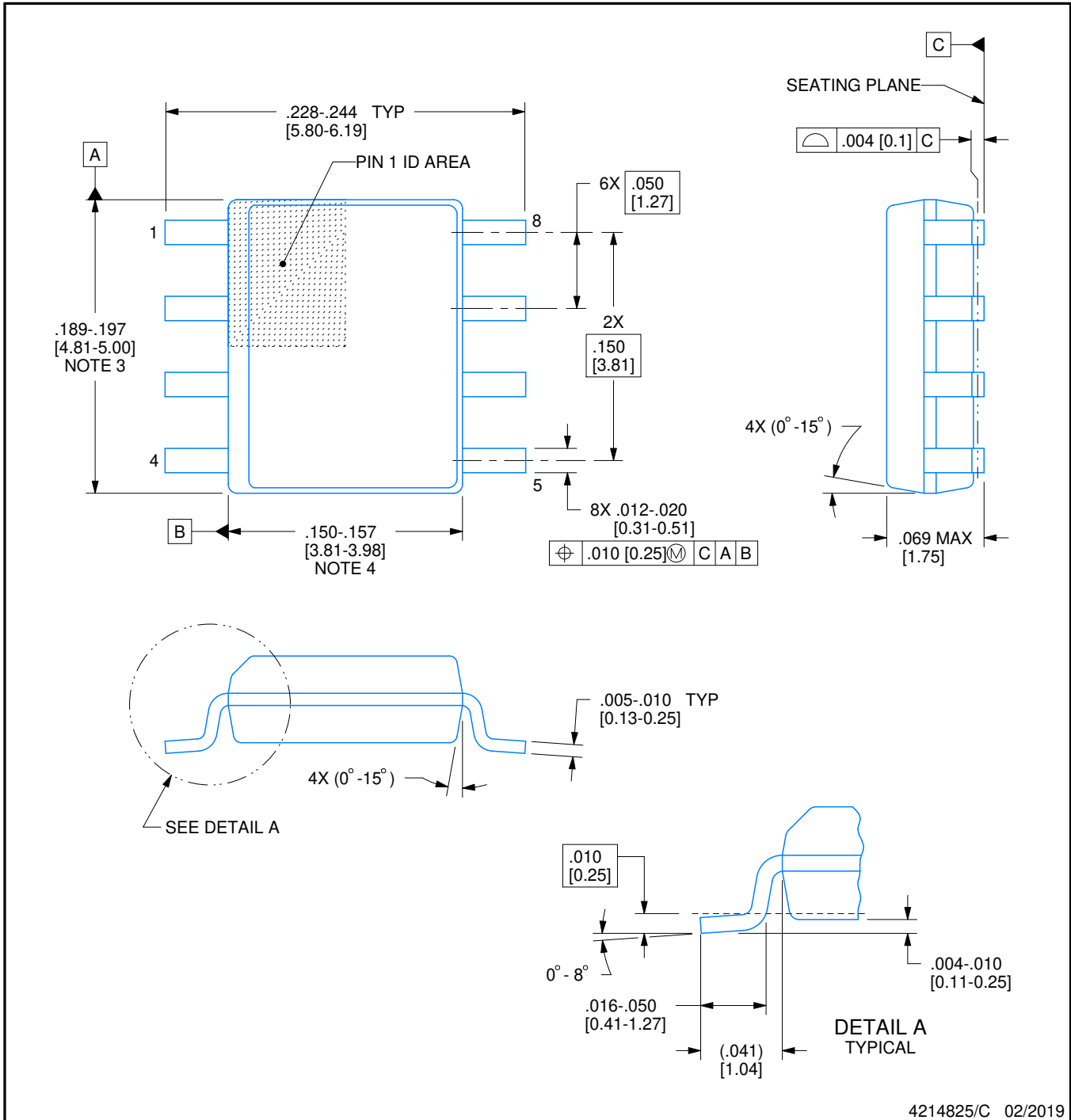

4214825/C 02/2019

NOTES:

1. Linear dimensions are in inches [millimeters]. Dimensions in parenthesis are for reference only. Controlling dimensions are in inches. Dimensioning and tolerancing per ASME Y14.5M.
2. This drawing is subject to change without notice.
3. This dimension does not include mold flash, protrusions, or gate burrs. Mold flash, protrusions, or gate burrs shall not exceed .006 [0.15] per side.
4. This dimension does not include interlead flash.
5. Reference JEDEC registration MS-012, variation AA.

EXAMPLE BOARD LAYOUT

D0008A

SOIC - 1.75 mm max height

SMALL OUTLINE INTEGRATED CIRCUIT



LAND PATTERN EXAMPLE
EXPOSED METAL SHOWN
SCALE:8X



SOLDER MASK DETAILS

4214825/C 02/2019

NOTES: (continued)

- 6. Publication IPC-7351 may have alternate designs.
- 7. Solder mask tolerances between and around signal pads can vary based on board fabrication site.

EXAMPLE STENCIL DESIGN

D0008A

SOIC - 1.75 mm max height

SMALL OUTLINE INTEGRATED CIRCUIT



SOLDER PASTE EXAMPLE
BASED ON .005 INCH [0.125 MM] THICK STENCIL
SCALE:8X

4214825/C 02/2019

NOTES: (continued)

8. Laser cutting apertures with trapezoidal walls and rounded corners may offer better paste release. IPC-7525 may have alternate design recommendations.
9. Board assembly site may have different recommendations for stencil design.

IMPORTANT NOTICE AND DISCLAIMER

TI PROVIDES TECHNICAL AND RELIABILITY DATA (INCLUDING DATA SHEETS), DESIGN RESOURCES (INCLUDING REFERENCE DESIGNS), APPLICATION OR OTHER DESIGN ADVICE, WEB TOOLS, SAFETY INFORMATION, AND OTHER RESOURCES "AS IS" AND WITH ALL FAULTS, AND DISCLAIMS ALL WARRANTIES, EXPRESS AND IMPLIED, INCLUDING WITHOUT LIMITATION ANY IMPLIED WARRANTIES OF MERCHANTABILITY, FITNESS FOR A PARTICULAR PURPOSE OR NON-INFRINGEMENT OF THIRD PARTY INTELLECTUAL PROPERTY RIGHTS.

These resources are intended for skilled developers designing with TI products. You are solely responsible for (1) selecting the appropriate TI products for your application, (2) designing, validating and testing your application, and (3) ensuring your application meets applicable standards, and any other safety, security, regulatory or other requirements.

These resources are subject to change without notice. TI grants you permission to use these resources only for development of an application that uses the TI products described in the resource. Other reproduction and display of these resources is prohibited. No license is granted to any other TI intellectual property right or to any third party intellectual property right. TI disclaims responsibility for, and you will fully indemnify TI and its representatives against, any claims, damages, costs, losses, and liabilities arising out of your use of these resources.

TI's products are provided subject to [TI's Terms of Sale](#) or other applicable terms available either on ti.com or provided in conjunction with such TI products. TI's provision of these resources does not expand or otherwise alter TI's applicable warranties or warranty disclaimers for TI products.

TI objects to and rejects any additional or different terms you may have proposed.

Mailing Address: Texas Instruments, Post Office Box 655303, Dallas, Texas 75265
Copyright © 2022, Texas Instruments Incorporated