

Automotive AEC-Q100 Qualified 1-to-1 Differential-to-LVCMOS/LVTTL Translator

Features

- One LVCMOS/LVTTL output
- Differential CLK/nCLK input pair
- CLK/nCLK pair can accept the following differential input levels: LVPECL, LVDS, LVHSTL, SSTL, HCSL
- Output frequency: 360MHz
- Part-to-part skew: 500ps (maximum)
- Additive phase jitter, RMS: 0.09ps (typical), 3.3V output
- Full 3.3V and 2.5V operating supply
- -40°C to 105°C ambient operating temperature
- AEC-Q100 Qualified
- Automotive Grade 2 temperature range (-40 to 105 °C)
- Automotive Grade 3 temperature range (-40 to 85 °C)
- Totally Lead-Free & Fully RoHS Compliant (Notes 1 & 2)
- Halogen and Antimony Free. “Green” Device (Note 3)
- The PI6C49CB01Q is suitable for automotive applications requiring specific change control and is AEC-Q100 qualified, has a grade 2, -40 to 105 °C temperature rating and grade 3, -40 to 85 °C temperature rating, is PPAP capable, and is manufactured in IATF16949:2016 certified facilities.
- Package: 8-Pin, SOIC (W)

Description

The PI6C49CB01Q is a 1-to-1 Differential-to-LVCMOS/LVTTL Translator High Performance Buffer. The differential input is highly flexible and can accept LVPECL, LVDS, LVHSTL, SSTL, and HCSL. The small 8-lead SOIC footprint makes this device ideal for use in applications with limited board space.

Block Diagram

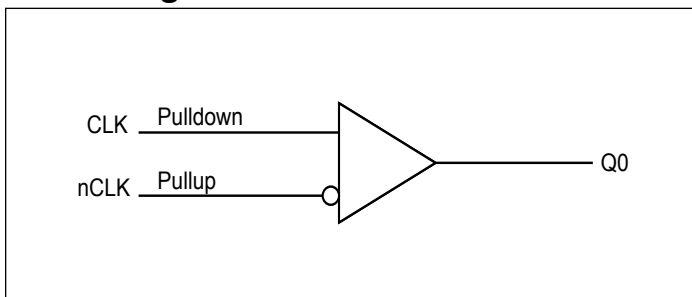

Notes:

1. No purposely added lead. Fully EU Directive 2002/95/EC (RoHS), 2011/65/EU (RoHS 2) & 2015/863/EU (RoHS 3) compliant.
2. See <https://www.diodes.com/quality/lead-free/> for more information about Diodes Incorporated’s definitions of Halogen- and Antimony-free, “Green” and Lead-free.
3. Halogen- and Antimony-free “Green” products are defined as those which contain <900ppm bromine, <900ppm chlorine (<1500ppm total Br + Cl) and <1000ppm antimony compounds.

Pin Configuration

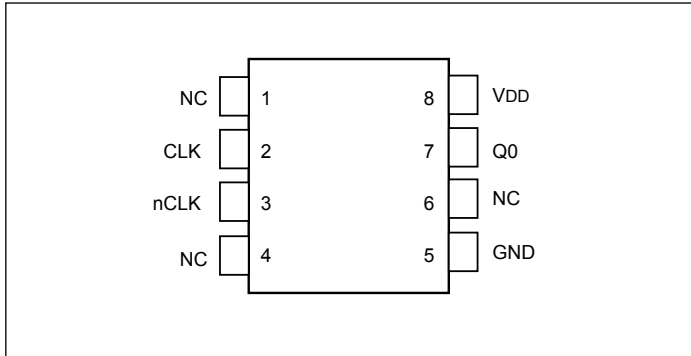

Pin Descriptions

Pin#	Pin Name	Pin Type		Pin Description
1, 4, 6	NC	Unused		No connect.
2	CLK	Input	Pulldown	Non-inverting differential clock input.
3	nCLK	Input	Pullup	Inverting differential clock input.
5	GND	Power		Power supply ground.
7	Q0	Output		Single-ended clock output. LVCMOS/LVTTL interface levels.
8	VDD	Power		Positive supply pin.

Note: *Pullup* and *Pulldown* refer to internal input resistors.

Pin Characteristics

Symbol	Parameter	Test Conditions	Min.	Typ.	Max.	Units
C_{IN}	Input Capacitance			4		pF
R_{PULLUP}	Input Pullup Resistor			51		k Ω
$R_{PULLDOWN}$	Input Pulldown Resistor			51		k Ω
C_{PD}	Power Dissipation Capacitance	VDD = 3.6V		23		pF
R_{OUT}	Output Impedance		5	7	13	Ω

Maximum Ratings

(Above which useful life may be impaired. For user guidelines, not tested.)

Supply Voltage, VDD	4.6V
Inputs, V _I	-0.5V to VDD+0.5V
Output, V _O	-0.5V to VDD+0.5V
Package Thermal Impedance, θ_{JA}	103°C/W (0 lfpm)
Storage Temperature, T _{STG}	-65°C to 150°C
ESD Protection (Input)	2000V min (HBM)
Junction Temperature	125°C (Max)

Note:

Stresses beyond those listed under Absolute Maximum Ratings may cause permanent damage to the device. These ratings are stress specifications only. Functional operation of product at these conditions or any conditions beyond those listed in the DC Characteristics or AC Characteristics is not implied. Exposure to absolute maximum rating conditions for extended periods may affect product reliability.

Recommended Operation Conditions

Parameter	Min.	Typ.	Max.	Units
Ambient Operating Temperature (Automotive Grade 2)	-40		105	°C
Ambient Operating Temperature (Automotive Grade 3)	-40		85	°C
Power Supply Voltage (measured in respect to GND)	2.375		3.465	V

DC Electrical Characteristics

Power Supply DC Characteristics, VDD = 3.3V ± 0.3V or 2.5V ± 5%, T_A = -40°C to 105°C

Symbol	Parameter	Conditions	Min.	Typ.	Max.	Units
VDD	Positive Supply Voltage		3.0	3.3	3.6	V
			2.375	2.5	2.625	V
IDD	Power Supply Current	25MHz, unloaded			25	mA
		250MHz, unloaded			35	mA

LVC MOS / LV TTL DC Characteristics, VDD = 3.3V ± 0.3V or 2.5V ± 5%, T_A = -40°C to 105°C

Symbol	Parameter	Conditions	Min.	Typ.	Max.	Units
V _{OH}	Output High Voltage ⁽¹⁾	VDD = 3.6V	2.6		3.6	V
		VDD = 2.625V	1.8		2.625	V
V _{OL}	Output Low Voltage ⁽¹⁾	VDD = 3.6V or 2.625V			0.5	V

Note:

1. Outputs terminated with 50Ω to VDD/2.

Differential DC Characteristics, VDD = 3.3V ± 0.3V or 2.5V ± 5%, T_A = -40°C to 105°C

Symbol	Parameter	Conditions	Min.	Typ.	Max.	Units	
I _{IH}	Input High Current	nCLK	V _{IN} = VDD = 3.6V or 2.625V			5	μA
		CLK	V _{IN} = VDD = 3.6V or 2.625V			150	μA
I _{IL}	Input Low Current	nCLK	V _{IN} = 0V, VDD = 3.6V or 2.625V	-150			μA
		CLK	V _{IN} = 0V, VDD = 3.6V or 2.625V	-5			μA
V _{PP}	Peak-to-Peak Input Voltage		0.15		1.3	V	
V _{CRM}	Common Mode Input Voltage ⁽¹⁾⁽²⁾		GND + 0.5		VDD - 0.85	V	

Note:

1. For single ended applications, the maximum input voltage for CLK, nCLK is VDD + 0.3V.

2. Common mode voltage is defined as (V_{IH} + V_{IL})/2.

AC Electrical Characteristics

AC Characteristics, VDD = 3.3V ± 0.3V, T_A = -40°C to 105°C

Symbol	Parameter	Conditions	Min.	Typ.	Max.	Units
f _{MAX}	Output Frequency		4		360	MHz
t _{PD}	Propagation Delay ⁽¹⁾	f ≤ 350MHz	1.6	1.8	2.0	ns
tsk(pp)	Part-to-Part Skew ⁽²⁾⁽³⁾				500	ps
tjit	Buffer Additive Phase Jitter, RMS	156.25MHz, Integration Range (12kHz – 20MHz)		0.09		ps
		125MHz, Integration Range (12kHz – 20MHz)		0.15		
t _R /t _F	Output Rise/Fall Time	0.8V to 2V	80	250	350	ps
odc	Output Duty Cycle	f ≤ 166MHz	45	50	55	%
		166MHz < f ≤ 350MHz	40	50	60	%

Note:

1. Electrical parameters are guaranteed over the specified ambient operating temperature range. The device will meet specifications after thermal equilibrium has been reached under these conditions.

All parameters measured at f_{MAX} unless noted otherwise.

2. Measured from the differential input crossing point to the output at VDD/2.

3. Defined as skew between outputs on different devices operating at the same supply voltage and with equal load conditions. Using the same type of inputs on each device, the outputs are measured at VDD/2.

AC Characteristics, VDD = 2.5V ± 5%, T_A = -40°C to 105°C

Symbol	Parameter	Conditions	Min.	Typ.	Max.	Units
f _{MAX}	Output Frequency		4		360	MHz
t _{PD}	Propagation Delay ⁽¹⁾	f ≤ 350MHz	1.9	2.2	2.5	ns
tsk(pp)	Part-to-Part Skew ⁽²⁾⁽³⁾				500	ps
tjit	Buffer Additive Phase Jitter, RMS	156.25MHz, Integration Range (12kHz – 20MHz)		0.04		ps
		125MHz, Integration Range (12kHz – 20MHz)		0.14		
t _R /t _F	Output Rise/Fall Time	20% to 80%	180		350	ps
odc	Output Duty Cycle	f ≤ 250MHz	45	50	55	%
		250MHz < f ≤ 350MHz	40	50	60	%

Note:

1. Electrical parameters are guaranteed over the specified ambient operating temperature range. The device will meet specifications after thermal equilibrium has been reached under these conditions.

All parameters measured at f_{MAX} unless noted otherwise.

2. Measured from the differential input crossing point to the output at VDD/2.

3. Defined as skew between outputs on different devices operating at the same supply voltage and with equal load conditions. Using the same type of inputs on each device, the outputs are measured at VDD/2.

Application Information

Wiring the differential input to accept single ended levels

Figure 1 shows how the differential input can be wired to accept single ended levels. The reference voltage $V_{REF} = V_{DD}/2$ is generated by the bias resistors R1, R2 and C1. This bias circuit should be located as close as possible to the input pin. The ratio of R1 and R2 might need to be adjusted to position the V_{REF} in the center of the input voltage swing. For example, if the input clock swing is only 2.5V and $V_{DD} = 3.3V$, V_{REF} should be 1.25V and $R1/R2 = 0.609$.

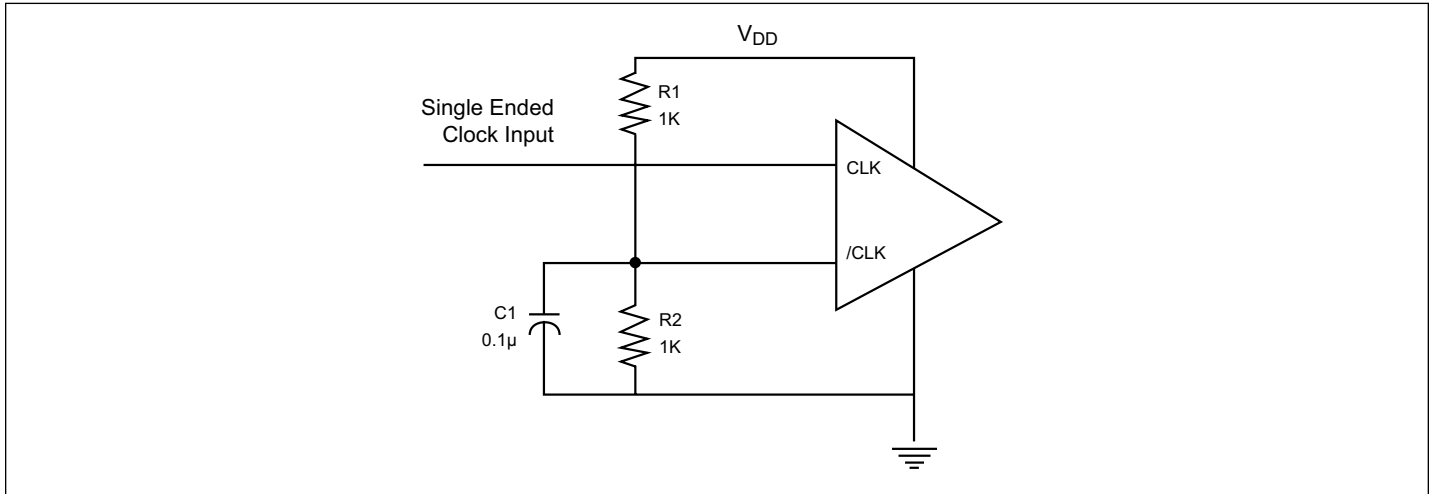

Figure 1. Single-ended Input to Differential Input Device

Thermal Information

Symbol	Description	Condition	
Θ_{JA}	Junction-to-ambient thermal resistance	Still air	157 °C/W
Θ_{JC}	Junction-to-case thermal resistance		42 °C/W

Part Marking

Top mark not available at this time. To obtain advance information regarding the top mark, please contact your local sales representative.

PI6C49CB01Q

Packaging Mechanical: 8-SOIC (W)

SYMBOLS	MIN.	NOM.	MAX.
A	—	—	1.75
A1	0.10	—	0.25
A2	1.25	—	—
b	0.31	—	0.51
c	0.10	—	0.25
D	4.80	4.90	5.00
E	5.80	6.00	6.20
E1	3.80	3.90	4.00
e	1.27 BSC		
L	0.40	—	1.27
h	0.25	—	0.50
θ°	0	—	8

UNIT : mm

NOTE :
 1. ALL DIMENSIONS ARE IN mm. ANGLES IN DEGREES
 2. DIMENSIONS EXCLUDE BURRS, MOLD FLASH OR PROTRUSIONS
 3. REFER JEDEC MS-012

PERICOM
Enabling Serial Connectivity

DATE: 02/21/14

DESCRIPTION: 8-Pin, 150mil-Wide, SOIC

PACKAGE CODE: W (W8)

DOCUMENT CONTROL #: PD-1001

REVISION: G

For latest package info.

please check: <http://www.diodes.com/design/support/packaging/pericom-packaging/packaging-mechanicals-and-thermal-characteristics/>

Ordering Information

Ordering Code	Package Code	Operating Temperature	Package Description
PI6C49CB01Q2WEX	W	-40 to 105°C	8-pin, 150mil-Wide (SOIC)
PI6C49CB01Q3WEX	W	-40 to 85°C	8-pin, 150mil-Wide (SOIC)

Notes:

1. No purposely added lead. Fully EU Directive 2002/95/EC (RoHS), 2011/65/EU (RoHS 2) & 2015/863/EU (RoHS 3) compliant.
2. See <https://www.diodes.com/quality/lead-free/> for more information about Diodes Incorporated's definitions of Halogen- and Antimony-free, "Green" and Lead-free.
3. Halogen- and Antimony-free "Green" products are defined as those which contain <900ppm bromine, <900ppm chlorine (<1500ppm total Br + Cl) and <1000ppm antimony compounds.
4. Q = Automotive Compliant
5. 2 and 3 = AEC-Q100 Grade Level
6. E = Pb-free and Green
7. X suffix = Tape/Reel

IMPORTANT NOTICE

DIODES INCORPORATED MAKES NO WARRANTY OF ANY KIND, EXPRESS OR IMPLIED, WITH REGARDS TO THIS DOCUMENT, INCLUDING, BUT NOT LIMITED TO, THE IMPLIED WARRANTIES OF MERCHANTABILITY AND FITNESS FOR A PARTICULAR PURPOSE (AND THEIR EQUIVALENTS UNDER THE LAWS OF ANY JURISDICTION).

Diodes Incorporated and its subsidiaries reserve the right to make modifications, enhancements, improvements, corrections or other changes without further notice to this document and any product described herein. Diodes Incorporated does not assume any liability arising out of the application or use of this document or any product described herein; neither does Diodes Incorporated convey any license under its patent or trademark rights, nor the rights of others. Any Customer or user of this document or products described herein in such applications shall assume all risks of such use and will agree to hold Diodes Incorporated and all the companies whose products are represented on Diodes Incorporated website, harmless against all damages.

Diodes Incorporated does not warrant or accept any liability whatsoever in respect of any products purchased through unauthorized sales channel.

Should Customers purchase or use Diodes Incorporated products for any unintended or unauthorized application, Customers shall indemnify and hold Diodes Incorporated and its representatives harmless against all claims, damages, expenses, and attorney fees arising out of, directly or indirectly, any claim of personal injury or death associated with such unintended or unauthorized application.

Products described herein may be covered by one or more United States, international or foreign patents pending. Product names and markings noted herein may also be covered by one or more United States, international or foreign trademarks.

This document is written in English but may be translated into multiple languages for reference. Only the English version of this document is the final and definitive format released by Diodes Incorporated.

LIFE SUPPORT

Diodes Incorporated products are specifically not authorized for use as critical components in life support devices or systems without the express written approval of the Chief Executive Officer of Diodes Incorporated. As used herein:

A. Life support devices or systems are devices or systems which:

1. are intended to implant into the body, or

2. support or sustain life and whose failure to perform when properly used in accordance with instructions for use provided in the labeling can be reasonably expected to result in significant injury to the user.

B. A critical component is any component in a life support device or system whose failure to perform can be reasonably expected to cause the failure of the life support device or to affect its safety or effectiveness.

Customers represent that they have all necessary expertise in the safety and regulatory ramifications of their life support devices or systems, and acknowledge and agree that they are solely responsible for all legal, regulatory and safety-related requirements concerning their products and any use of Diodes Incorporated products in such safety-critical, life support devices or systems, notwithstanding any devices- or systems-related information or support that may be provided by Diodes Incorporated. Further, Customers must fully indemnify Diodes Incorporated and its representatives against any damages arising out of the use of Diodes Incorporated products in such safety-critical, life support devices or systems.

Copyright © 2016, Diodes Incorporated

www.diodes.com