

## **Introduction**

The SPC584B-DIS is a low-cost development board to evaluate and develop applications with the microcontroller SPC584B70E1 in eTQFP 64-pin package.

This document describes the hardware architecture of the SPC584B-DIS Discovery board and the way the jumpers can be set to enable specific functions.

# Contents

- 1 SPC584B-DIS Discovery board with SPC584B70E1 . . . . . 5**
- 1.1 SPC584B-DIS Discovery board . . . . . 5
  
- 2 Hardware overview . . . . . 7**
- 2.1 Power supply section . . . . . 7
  - 2.1.1 Jumpers configuration cable . . . . . 7
  - 2.1.2 Voltage regulators and jumpers . . . . . 7
- 2.2 Microcontroller power management . . . . . 9
- 2.3 Integrated Programmer/Debugger . . . . . 9
- 2.4 Crystal oscillator . . . . . 11
- 2.5 Reset circuit . . . . . 12
- 2.6 User LEDs, User Button . . . . . 13
- 2.7 Connectors . . . . . 14
  - 2.7.1 Arduino connectors . . . . . 14
  - 2.7.2 Extended Connectors (I/O Headers) . . . . . 16
  - 2.7.3 BT Module Connector . . . . . 20
  - 2.7.4 JTAG Connector . . . . . 20
  
- Appendix A Board layout. . . . . 21**
- A.1 PCB layout . . . . . 21
  
- Revision history . . . . . 23**

## List of tables

Table 1.	Power source and jumpers configuration . . . . .	7
Table 2.	Programmer/Debugger - Jumpers setting . . . . .	10
Table 3.	Crystal oscillator - jumper configuration . . . . .	12
Table 4.	Reset circuit - jumpers configuration . . . . .	13
Table 5.	CN6 - Arduino UNO-R3 Power . . . . .	14
Table 6.	CN8 - Arduino UNO-R3 Analog Input . . . . .	14
Table 7.	CN5 - Arduino UNO-R3 Digital PWM (D15÷D8). . . . .	15
Table 8.	CN9 - Arduino UNO-R3 Digital PWM (D7÷D0). . . . .	15
Table 9.	CN7 - Extended Connectors (I/O Headers) . . . . .	16
Table 10.	CN10 - Extended Connectors (I/O Headers) . . . . .	17
Table 11.	CN2 - BT Module Connector . . . . .	20
Table 12.	CN1 - JTAG Connector. . . . .	20
Table 13.	Document revision history . . . . .	23

## List of figures

Figure 1.	SPC584B-DIS . . . . .	5
Figure 2.	USB Port - 5 V input . . . . .	8
Figure 3.	+5 V regulator (external PSU) and 5 V selector (SB17-SB27) . . . . .	8
Figure 4.	+3.3 V voltage regulator and +3.3 V selector (SB26) . . . . .	8
Figure 5.	E3V3 and E5V jumpers . . . . .	9
Figure 6.	Microcontroller power management - Jumper setting . . . . .	9
Figure 7.	PLS Integrated Programmer/Debugger (part I) . . . . .	10
Figure 8.	PLS Integrated Programmer/Debugger (part II - Level shifters and EEPROM) . . . . .	11
Figure 9.	PLS Integrated Programmer/Debugger (part III - Jumper configuration) . . . . .	11
Figure 10.	Crystal oscillator (default configuration) . . . . .	12
Figure 11.	Reset circuit . . . . .	13
Figure 12.	User LEDs . . . . .	13
Figure 13.	User Push-Button . . . . .	14
Figure 14.	PCB Layout - Top Side . . . . .	21
Figure 15.	PCB Layout - Bottom Side . . . . .	22

# 1 SPC584B-DIS Discovery board with SPC584B70E1

## 1.1 SPC584B-DIS Discovery board

The SPC584B-DIS Discovery board is an evaluation tool supporting STMicroelectronics SPC584B70E1, a high performance e200z4single core 32-bit Power Architecture technology CPU 120MHz, 2MB Code Flash in eQFP64 package. The SPC584B-DIS allows full access to peripherals such as DSPI, LINFlexD, ISO CAN-FD. The new features satisfy the ASIL-B requirements.

Figure 1. SPC584B-DIS

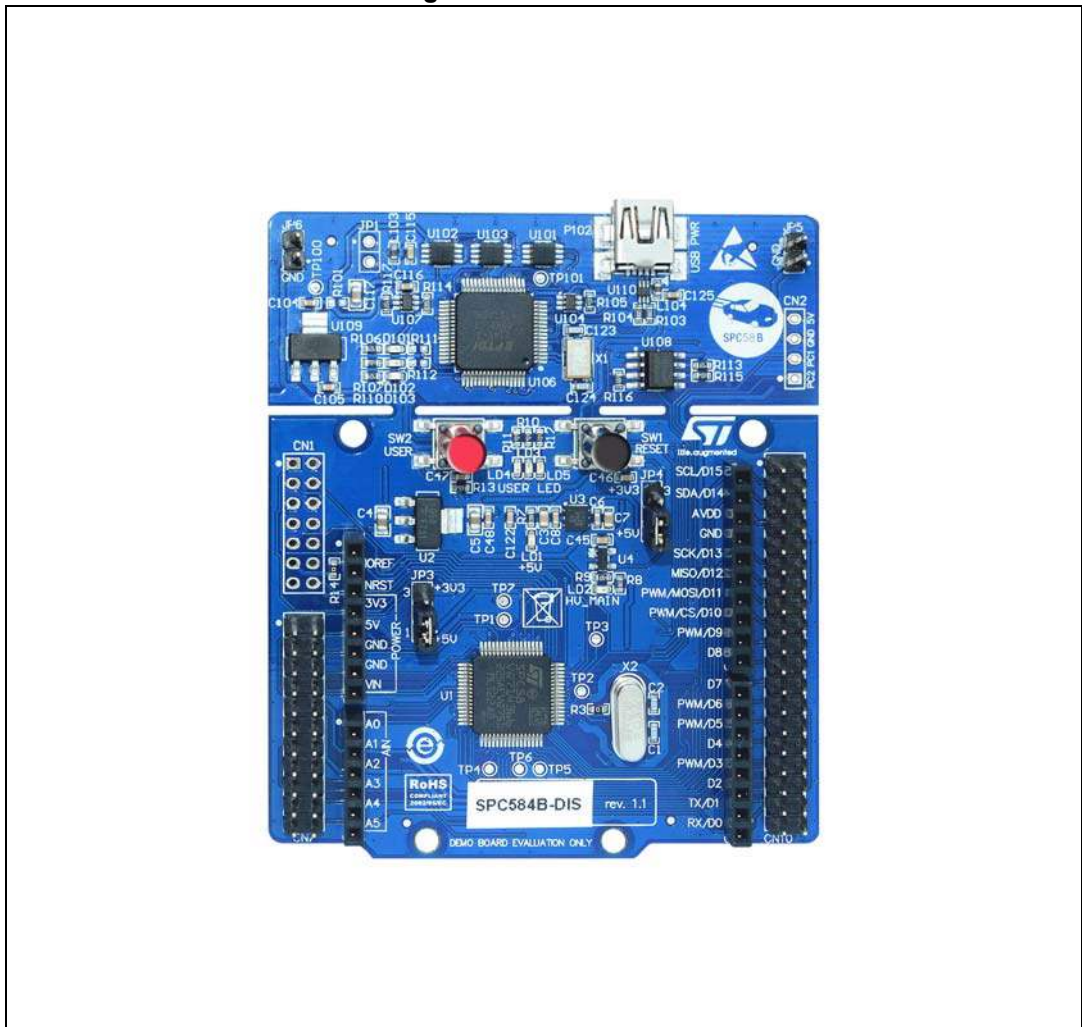

The board integrates a PLS programmer/debugger that allows debugging and programming the microcontroller via USB cable. In addition, it allows enabling a USART communication channel (USB Virtual COM port).

Dedicated connectors allow plugging shields Arduino UNO-compatible; this feature makes it easy to expand the functionality of the SPC584B-DIS.

All CPUs pins are connected to two-pin arrays; this solution simplifies the debug activity as well as it reduces the effort to connect the SPC584B-DIS to the final user application board.

A standard 2x7pin JTAG port is available<sup>(a)</sup> to program and debug the microcontroller by using third part tools.

---

a. The male connector 2x7 pins is not assembled

## 2 Hardware overview

### 2.1 Power supply section

SPC584B-DIS can be supplied by using some DC sources, setting some jumpers properly:

- by the host PC through the USB cable (+5 V; this is the default configuration);
- by an external source connected to VIN pin (CN6 pin 8, CN7 pin 8) (7÷12V<sup>(b)</sup>)
- by an external source connected to E5V (CN6 pin 5, CN7 pin 17 and CN10 pin 8)
- by an external source connected both to E3V3 (CN6 pin4 and CN7 pin 15) and to E5V

The external source can be a PSU, or the user application. The external sources or the PSUs connected to the board must be SELV<sup>(c)</sup> compliant, self-protected and with limited current capability.

#### 2.1.1 Jumpers configuration cable

**Table 1. Power source and jumpers configuration**

Power Source	Jumper configuration				
	+5V		+3.3V	E5V	E3V3
Jumper	SB17	SB27	SB26	SB14	SB6
PCB - USB Cable	Close	Open	Close	Close	Close
External source - VIN	Open	Close	Close	Close	Close
External source - E5V	Open	Open	Close	Close	Close
External source - E3V3 and E5V	Open	Open	Open	Close	Close

#### 2.1.2 Voltage regulators and jumpers

This paragraph depicts the power supply section and the how to configure the jumpers.

LD1 monitors the +5 V supply. U2 and U3 are linear regulator; the output voltage is 5 V and 3.3 V respectively.

b. The maximum input voltage level is limited by the thermal dissipation of the linear regulators; the input voltage level must be selected and limited according to the microcontroller current absorption.

c. "SELV" means "Safety Extra-Low Voltage".

Figure 2. USB Port - 5 V input

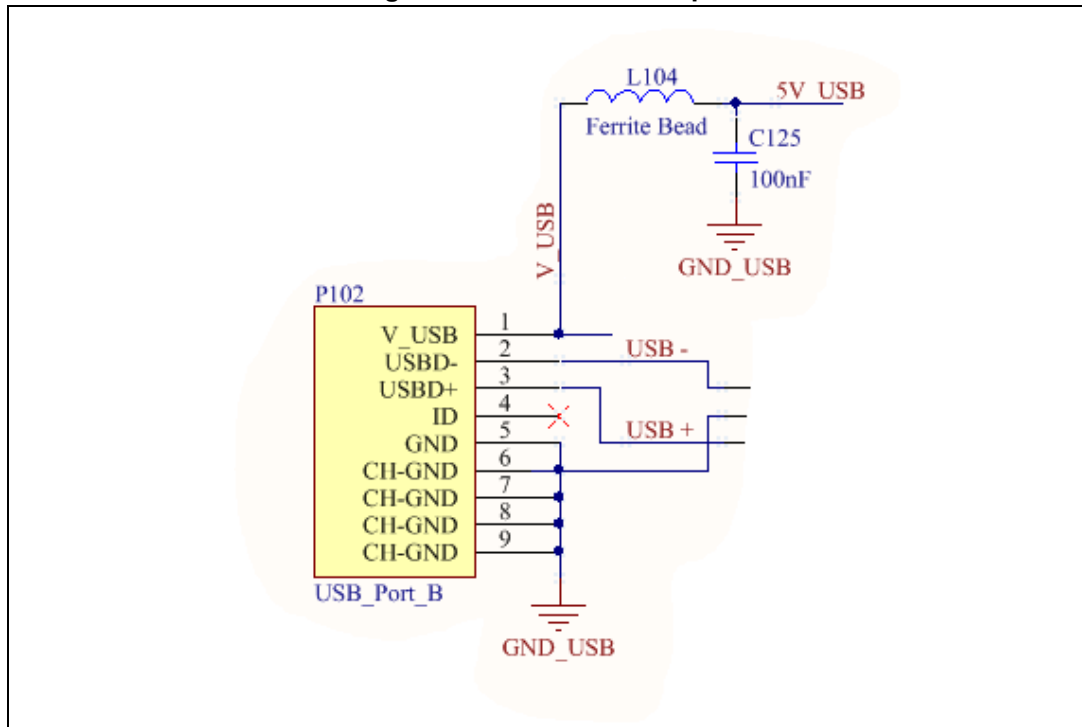

Figure 3. +5 V regulator (external PSU) and 5 V selector (SB17-SB27)

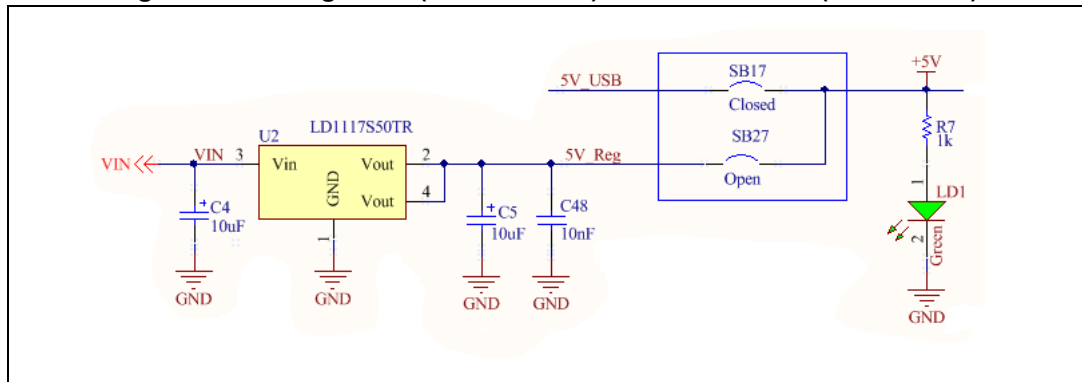

Figure 4. +3.3 V voltage regulator and +3.3 V selector (SB26)

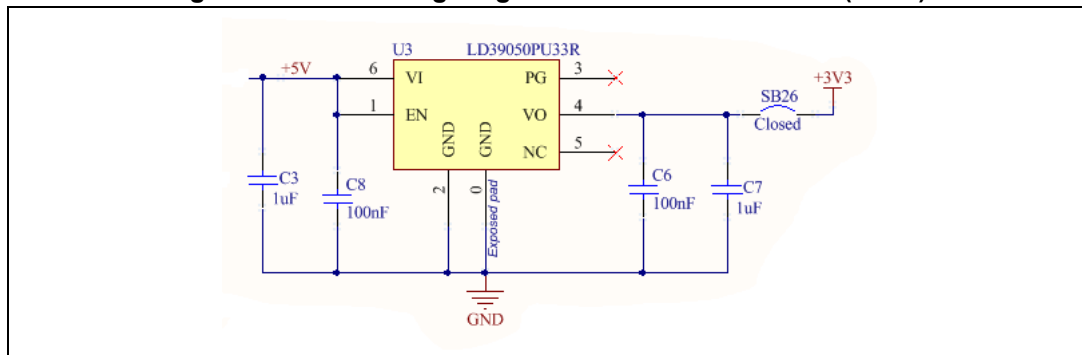
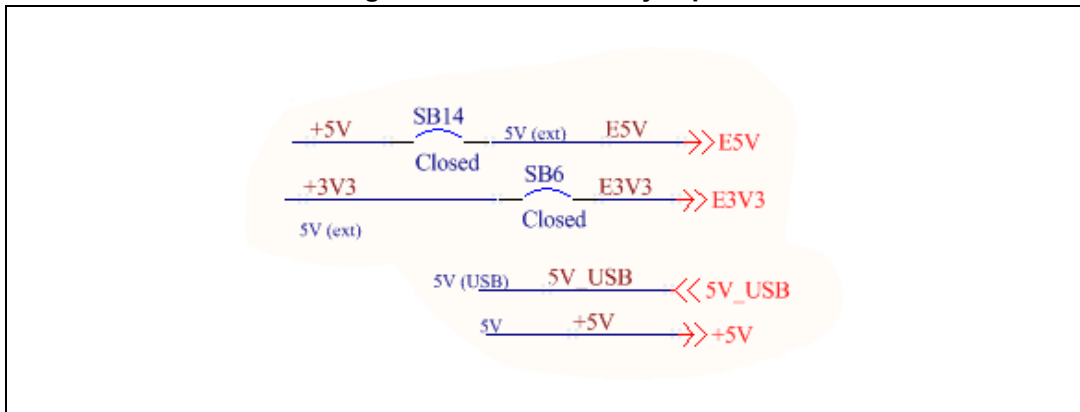



Figure 5. E3V3 and E5V jumpers



## 2.2 Microcontroller power management

JP3 and JP4 set the supply voltage levels of VDD\_HV\_IO\_MAIN and VDD\_HV\_ADV.

Figure 6. Microcontroller power management - Jumper setting

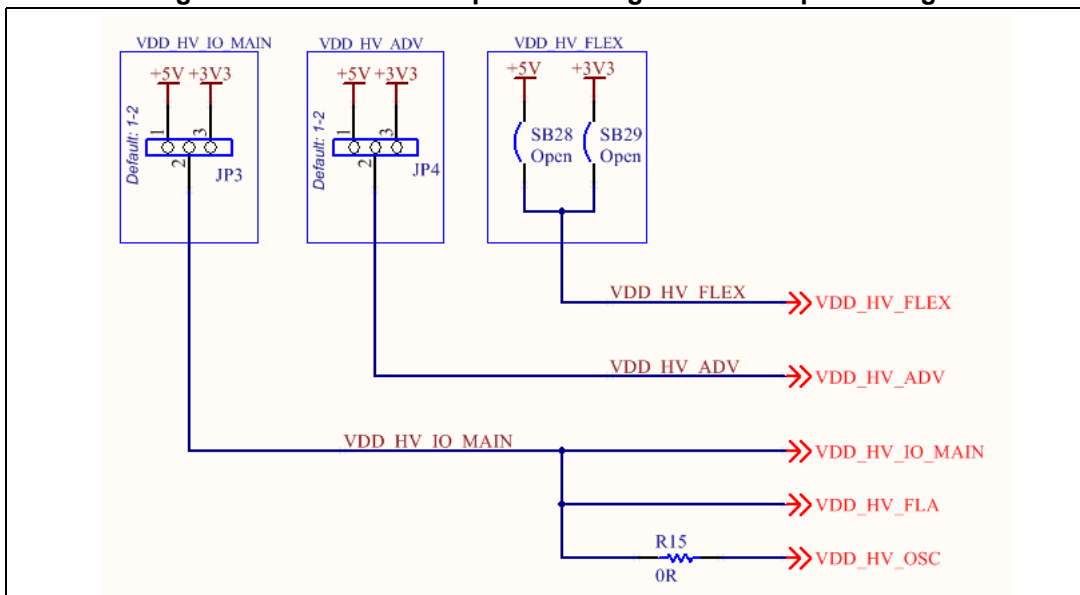

## 2.3 Integrated Programmer/Debugger

The integrated programmer/debugger allows the user to program the microcontroller and debug the software applications; it is based on the UDE PLS software.

The debugger serial number is reported on the label applied on the board (bottom side).

The integrated debugger SW is accessible via ST's free integrated development environment, SPC5Studio ([www.st.com/spc5studio](http://www.st.com/spc5studio)). To download the debugger software and to activate license refer to the PLS website.

A JTAG port allows connecting further HW/SW tools to program and debug the microcontroller<sup>(d)</sup>, with an external debugger the USB cable must be disconnected.

U106 can be configured to establish a serial communication port; pin 38 (Tx), pin 39 (Rx) and two level shifters implement this feature. [Table 2](#) shows how to set the jumpers.

*Note:* The board comes with the integrated programmer enabled.

**Table 2. Programmer/Debugger - Jumpers setting**

	SB23	SB8	SB9	SB10	SB11	SB12	SB13	SB31	SB32
PLS Integrated Programmer	Close	Close	Close	Close	Close	Close	Close	Close	Close
External JTAG Programmer	Open	Open	Open	Open	Open	Open	Open	Open	Open

**Figure 7. PLS Integrated Programmer/Debugger (part I)**

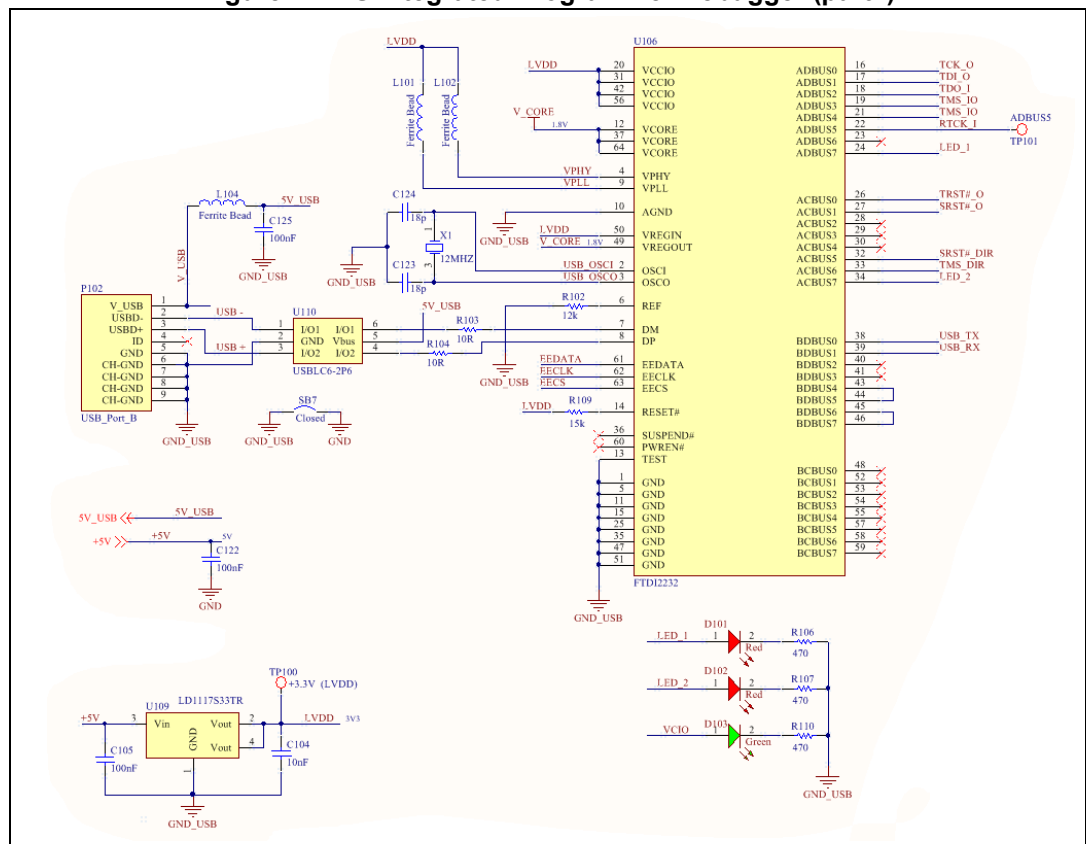

d. The JTAG connector 2x7 male pin array is not assembled.

Figure 8. PLS Integrated Programmer/Debugger (part II - Level shifters and EEPROM)

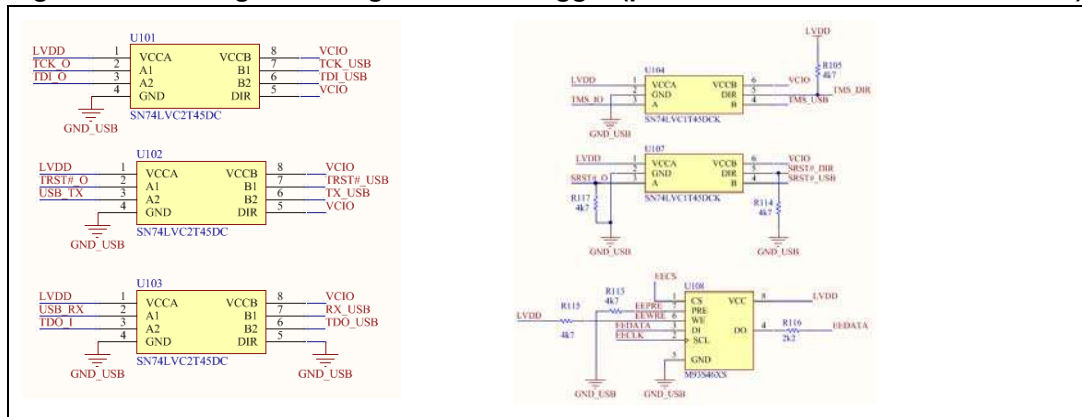
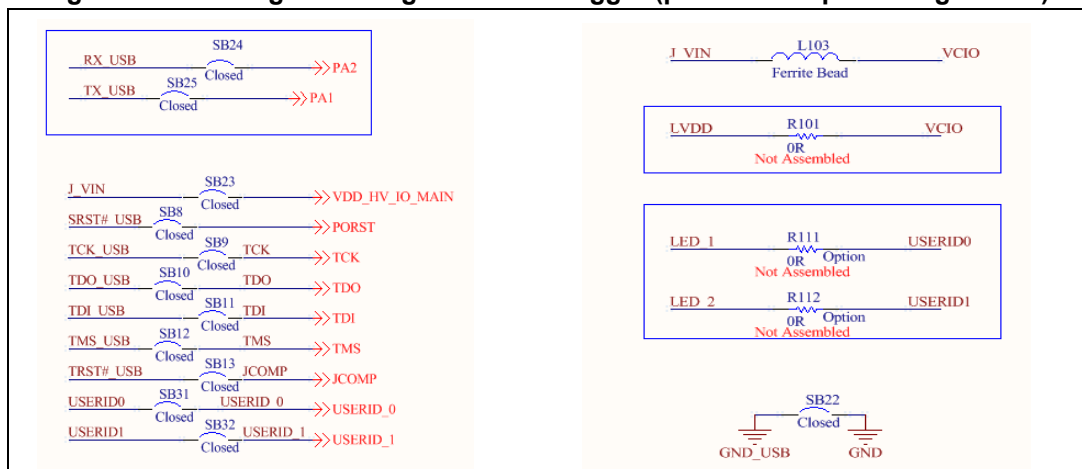

Figure 9. PLS Integrated Programmer/Debugger (part III - Jumper configuration)



## 2.4 Crystal oscillator

The board accepts different clock sources. In the default HW configuration a 40MHz crystal (X2) is connected to the microcontroller oscillator pins.

Figure 10. Crystal oscillator (default configuration)

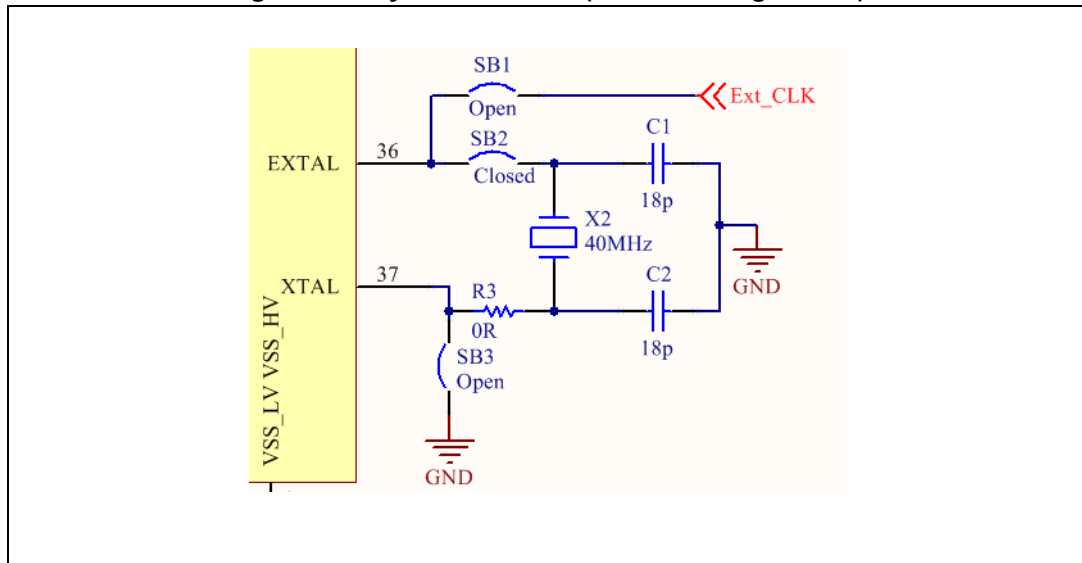

The jumpers SB1, SB2 and SB3 allow enabling further input clock as described in [Table 3](#).

Table 3. Crystal oscillator - jumper configuration

	SB1	SB2	SB3
Crystal (40MHz)	Open	Close	Open
Ext Clock	Close	Open	Open

## 2.5 Reset circuit

[Figure 11](#) shows the reset circuit; it generates a sharp signal to reset the microcontroller when the pushbutton SW1 is pushed.

SW1 triggers the STM6315RB-2.63V and it generates reset pulse (active low signal); D2 is turned on when the reset pulse is generated. The solder jumper SB16 allows to disconnect PORST and NRST signals (in the default configuration it is closed).

The internal reset generator can be disabled and the reset signal can be provided by an external source connected to CN6 pin3; to implement this configuration SB15 should be removed.

Figure 11. Reset circuit

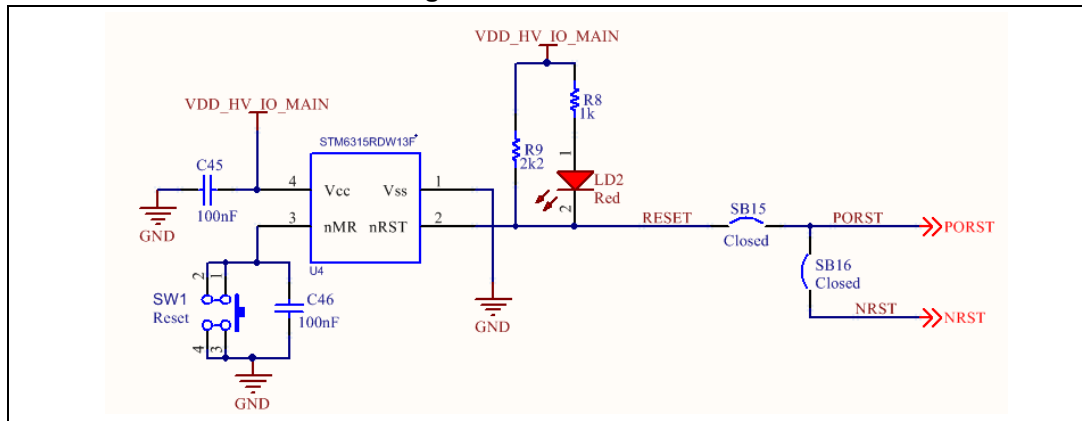

Table 4. Reset circuit - jumpers configuration

	SB15	SB16
Internal reset circuit	Close	Close
External reset circuit	Open	Close

## 2.6 User LEDs, User Button

In the SPC584B-DIS board three LEDs are available for user purposes; see [Figure 12](#). The jumpers SB18, SB19 and SB20 allow disconnecting the anode of each LED and then let the user to reserve these pins for a different purpose.

Figure 12. User LEDs

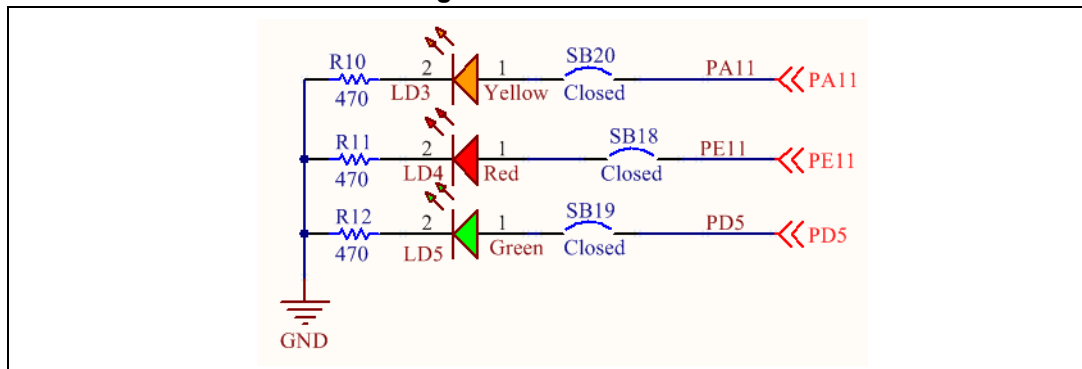

The pushbutton SW2 is reserved for user purpose (see [Figure 13](#)). If the jumper SB21 is left open, PF2 port is available for a different purpose.

Figure 13. User Push-Button

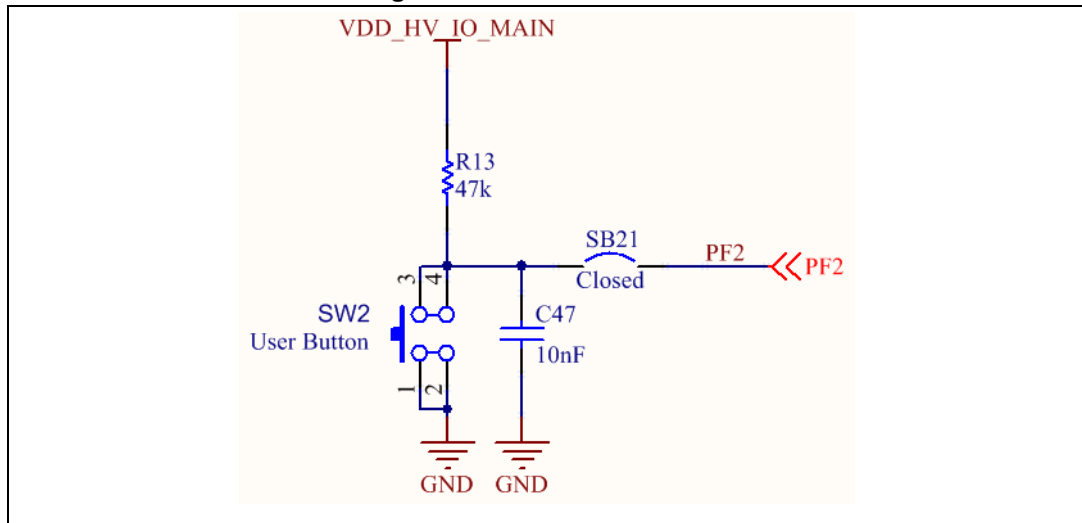

## 2.7 Connectors

### 2.7.1 Arduino connectors

Table 5. CN6 - Arduino UNO-R3 Power

Arduino UnoR3 Power	Connector CN6	
	CN6 Pin	Function / Signal
-	1	-
IOREF (3V3)	2	VDD_HV_IO_MAIN (3V3)
NRST	3	NRST
3V3	4	E3V3
5V	5	E5V
GND	6	GND
GND	7	GND
VIN	8	VIN

Table 6. CN8 - Arduino UNO-R3 Analog Input

Arduino UnoR3 Analog In	Connector CN8					
	CN8 Pin	uC Port	uC Pin	Function	Alternate Function (1)	Alternate Function (2)
A0	1	PE3	10	AN[17]	UC16	CLKOUT0
A1	2	PD12	8	AN[15]	UC14	SIN
A2	3	PD13	9	AN[16]	UC15	SCK

Table 6. CN8 - Arduino UNO-R3 Analog Input (continued)

Arduino UnoR3 Analog In	Connector CN8					
	CN8 Pin	uC Port	uC Pin	Function	Alternate Function (1)	Alternate Function (2)
A3	4	PE2	7	AN[13]	UC13	SOUT
A4	5	PI7	18	AN[50]		
A5	6	PI6	17	AN[49]		

Table 7. CN5 - Arduino UNO-R3 Digital PWM (D15÷D8)

Arduino UnoR3 Digital PWM (part 1)		Connector CN5						
		CN5 Pin	uC Port Pin	Function	Alternate Function (1)	Alternate Function (2)	Alternate Function (3)	
-	D8	1	PA11	53	UC16	M_CAN_2_RX	M_CAN_1_RX	LinFlexD 2 RX
PWM	D9	2	PA10	52	UC15	M_CAN_2_TX	M_CAN_1_TX	LINFlexD _2 TX
PWM/C S	D10	3	PB11	29	CS0 - DSPI0	UC24		
PWM/M OSI	D11	4	PG12	25	SOUT - DSPI0	UC20	AN[58]	
MSO	D12	5	PD11	26	SIN - DSPI0	UC21	AN[63]	
SCK (LED)	D13	6	PG11	24	SCK - DSPI0	UC19	AN[57]	
I2C SDA	D14	7	PB9	31	I2C - SDA	UC26		
I2C SCL	D15	8	PB8	32	I2C - SCL	UC27		

Table 8. CN9 - Arduino UNO-R3 Digital PWM (D7÷D0)

Arduino UnoR3 Digital PWM (part2)		CN9						
		CN9 Pin	uC Pin Port	Function	Alternate Function (1)	Alternate Function (2)	Alternate Function (3)	
RX	D0	1	PC3	4	LINFlex1 RXD	UC7		
TX	D1	2	PC4	3	LINFlex1 TXD	UC6		
	D2	3	PA1	51	LINFlex2 RXD	UC11	INT19	

**Table 8. CN9 - Arduino UNO-R3 Digital PWM (D7÷D0) (continued)**

Arduino UnoR3 Digital PWM (part2)		CN9						
		CN9 Pin	uC Pin Port	Function	Alternate Function (1)	Alternate Function (2)	Alternate Function (3)	
PWM	D3	4	PA2	50	LINFlex2 TXD	UC10	INT18	
	D4	5	PC13	61	UC28	SIN - DSPI1	M_CAN_ 1_TX	
PWM	D5	6	PE10	54	UC17	SIN - DSPI1	LINFlex0- RXD	
PWM	D6	7	PB10	30	UC25	SOUT - DSPI2	LINFlex0- TXD	INT3
	D7	8	PF3	63	UC2	CS1 - DSPI1	LINFlex2- TXD	INT9

**2.7.2 Extended Connectors (I/O Headers)**

**Table 9. CN7 - Extended Connectors (I/O Headers)**

Signal	Connector CN7					
	CN7 Pin	uC Port	uC Pin	Function	Alternate Function (1)	Alternate Function (2)
	1	PA11	53	SCK - DSPI_3	UC16	M_CAN_2_ RX
	2	PD14	1	M_CAN_0_ TX		
	3	PE11	55	SOUT - DSPI_3	UC18	LINFlexD0 TXD
	4	PD15	2	M_CAN_0_ RX	UC0	
	5	PC14	60	UC27	SCK - DSPI_1	
GND	6					
USER BUTTON	7	PF2	64	UC20	LINFlexD2 - XD	
VIN	8					
VDD_HV_IO	9					
AVDD	10					
GND	11					
A0 (CN8)	12					



Table 9. CN7 - Extended Connectors (I/O Headers) (continued)

Signal	Connector CN7					
	CN7 Pin	uC Port	uC Pin	Function	Alternate Function (1)	Alternate Function (2)
Ext Clock	13					
A1 (CN8)	14	PD12	8	AN[15]	UC14	SIN - DSPI_3
E3V3	15					
A2 (CN8)	16	PD13	9	AN[16]	UC15	SCK - DSPI_3
E5V	17					
A3 (CN8)	18	PE2	10	AN[13]	UC13	SOUT - DSPI_3
	19	PI3	15	AN[39]		
A4 (CN8)	20	PI7		AN[50]		
	21	PI4	16	AN[40]		
A5 (CN8)	22	PI6	17	AN[49]		

Table 10. CN10 - Extended Connectors (I/O Headers)

Signal	Connector CN10						
	CN10 Pin	uC Port	uC Pin	Function	Alternate Function (1)	Alternate Function (2)	Alternate Function (2)
	1	PD5	48	UC7	M_CAN_2_TX	INT15	
nc	2	-	-	-	-	-	
D15 (CN5)	3	PB8	32	SCL-I2C	UC27	SCK - DSPI_2	
	4	PH4	56	UC19	CS1 - DSPI_3		
D14 (CN5)	5	PB9	31	SDA-I2C	UC26	SDI - DSPI_2	
	6	PC12	62	UC13	CS1 - DSPI_3	M_CAN_1_RX	
AVDD (CN5)	7						
E5V	8						
GND	9						
GND	10						

**Table 10. CN10 - Extended Connectors (I/O Headers) (continued)**

Signal	Connector CN10						
	CN10 Pin	uC Port	uC Pin	Function	Alternate Function (1)	Alternate Function (2)	Alternate Function (2)
D13 (CN5)	11	PG11	24	SCK - DSPI_0	UC19	AN[57]	
	12	PC1	6	LINFlexD1 5 RXD	UC9		
D12 (CN5)	13	PD11	26	SIN - DSPI_0	UC21	AN[63]	
	14	PC2		LINFlexD1 5 TXD	UC8		
D11 (CN5)	15	PG12	25	SOUT - DSPI_0	UC20	AN[58]	
nc	16						
D10 (CN5)	17	PB11	29	CS0 - DSPI_0	UC24		
nc	18						
D9 (CN5)	19	PA10	52	UC15	M_CAN_2_TX	M_CAN_1_TX	LINFlex2 TXD
GND	20						
D8 (CN5)	21	PA11	53	UC16	M_CAN_2_RX	M_CAN_1_RX	LINFlex2 RXD
	22	PM14	46	M_CAN_1_RX	REQ7		
D7 (CN9)	23	PF3	63	UC2	CS1 - DSPI_1	LINFlex2 TXD	INT9
	24	PC15	59	UC26			
D6 (CN9)	25	PB10	30	UC25	SOUT - DSPI_2	LINFlex0 TXD	INT3
	26	PI2	14	M_CAN_3_RX	UC5		
D5 (CN9)	27	PE10	30	UC17	SIN - DSPI_3	LINFlex0 RXD	
	28	PI1	13	M_CAN_3_TX	UC4		
D4 (CN9)	29	PC13	61	UC28	SIN - DSPI_1	M_CAN_1_TX	
	30	PD0	58	SCK - DSPI_2	UC22	REQ4	
D3 (CN9)	31	PA2	50	LINFlex1 TXD	UC10	INT18	

Table 10. CN10 - Extended Connectors (I/O Headers) (continued)

Signal	Connector CN10						
	CN10 Pin	uC Port	uC Pin	Function	Alternate Function (1)	Alternate Function (2)	Alternate Function (2)
AGND	32						
D2 (CN9)	33	PA1	53	LINFlex1 RXD	UC11	INT19	
	34	PG10	23	AN[55]			
D1 (CN9)	35	PC4	3	LINFlex2 TXD	UC6		
nc	36						
D0 (CN9)	37	PC3	4	LINFlex2 RXD	UC7		
nc	38						

### 2.7.3 BT Module Connector

Table 11. CN2 - BT Module Connector

Signal	CN2 Connector				
	CN2 Pin	uC Port	uC Pin	Function	Alternate Function (1)
TXD	1	PC2	5	LINFlexD15 TXD	UC8
RXD	2	PC1	6	LINFlexD15 RXD	UC9
GND	3				
E5V	4				

### 2.7.4 JTAG Connector

Table 12. CN1 - JTAG Connector

CN1 Connector		
CN1 Pin	uC Pin	Function
1	38	TDI
2	-	GND
3	41	TDO
4	-	GND
5	43	TCK
6	-	GND
7	-	NC
8	-	NC
9	45	PORST
10	40	TMS
11	12	VDD_HV_IO
12	-	GND
13		NC
14	42	JCOMP

# Appendix A Board layout

## A.1 PCB layout

Figure 14. PCB Layout - Top Side

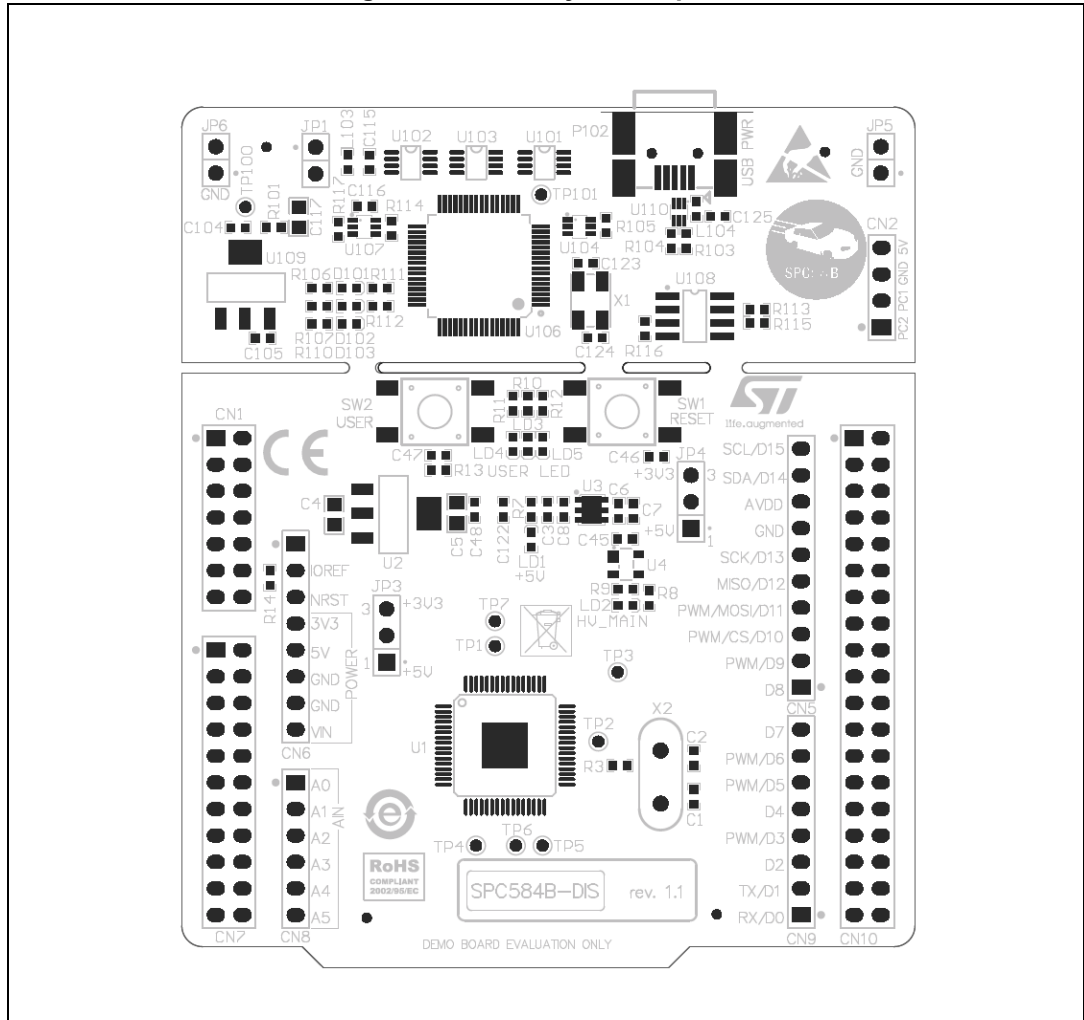
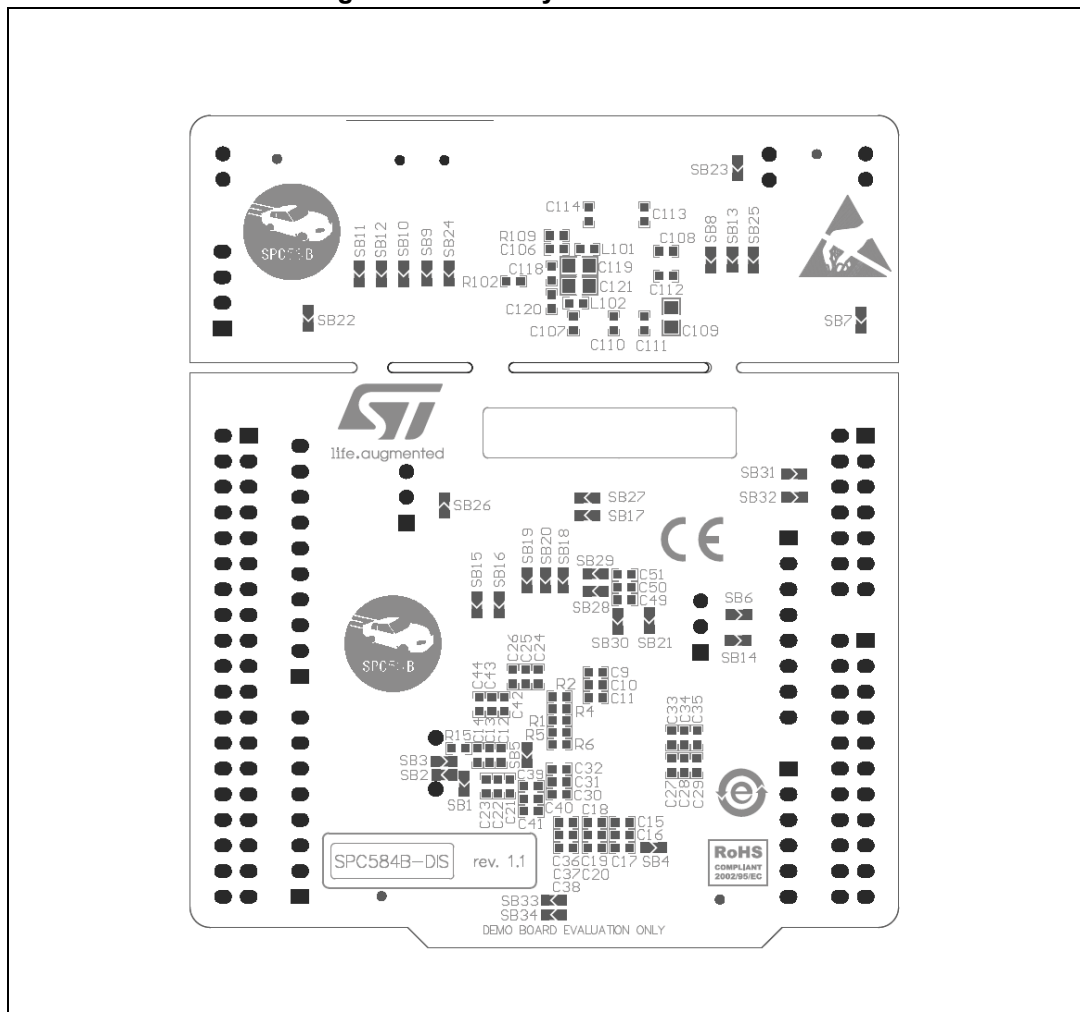

Figure 15. PCB Layout - Bottom Side



## Revision history

**Table 13. Document revision history**

Date	Revision	Changes
04-Sep-2018	1	Initial release.
15-Apr-2020	2	Updated <a href="#">Section 2.3: Integrated Programmer/Debugger</a> .

**IMPORTANT NOTICE – PLEASE READ CAREFULLY**

STMicroelectronics NV and its subsidiaries (“ST”) reserve the right to make changes, corrections, enhancements, modifications, and improvements to ST products and/or to this document at any time without notice. Purchasers should obtain the latest relevant information on ST products before placing orders. ST products are sold pursuant to ST’s terms and conditions of sale in place at the time of order acknowledgement.

Purchasers are solely responsible for the choice, selection, and use of ST products and ST assumes no liability for application assistance or the design of Purchasers’ products.

No license, express or implied, to any intellectual property right is granted by ST herein.

Resale of ST products with provisions different from the information set forth herein shall void any warranty granted by ST for such product.

ST and the ST logo are trademarks of ST. For additional information about ST trademarks, please refer to [www.st.com/trademarks](http://www.st.com/trademarks). All other product or service names are the property of their respective owners.

Information in this document supersedes and replaces information previously supplied in any prior versions of this document.

© 2020 STMicroelectronics – All rights reserved