

RECOMMENDED PCB LAYOUT

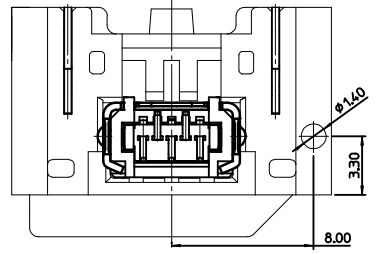
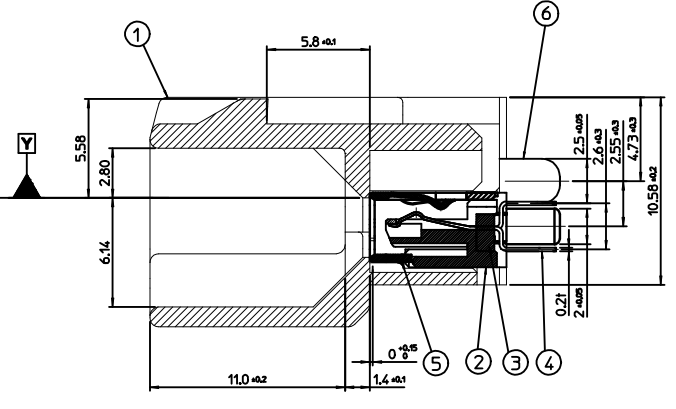
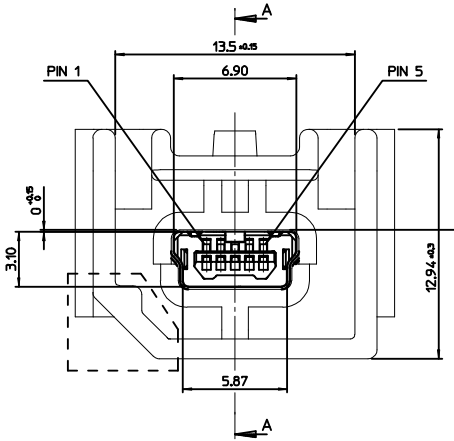

- NOTE**
- MATES WITH :
(MOLEX SERIES NO. - 111014, 111015, 111005, 111041, 111019, 111020)
 - SHROUD GEOMETRY AND ASSEMBLY WITH USB MINI-B CONNECTOR ARE ACCORDING TO USCAR STD 999-U-USB-Z01
 - FINISHES
- TERMINAL :
CONTACT AREA : Au 0.754m MIN.
SOLDER TAIL AREA : TIN 3.84m MIN.
UNDER PLATING : NI 1.04m MIN.
- SHIELD CASE :
3.04m MIN. TIN OVER NI 1.04m MIN.
- FITTING NAIL :
3.04m MIN. TIN OVER NI 1.04m MIN.
 - UNLESS OTHERWISE SPECIFIED, TYPICAL RECOMMENDED PCB MANUFACTURING TOLERANCE IS ±0.05
 - PACKAGING IS TRAY :
-STD. TYPE :48 PCS/TRAY, 5 TRAY/TRAY BOX, 240 PCS/TRAY BOX, 960 PCS/CARTON BOX)
-ST TYPE:32 PCS/TRAY, 3 TRAY/TRAY BOX, 96 PCS/TRAY BOX, 384 PCS/CARTON BOX)
 - PACKING IS EMBOSS:
"SEE SHEET 2 OF 2 OF THIS PRINT."
 - PRODUCT SPECIFICATION : PS-49616-001
 - PCB THICKNESS : 2.36mm(REFERENCE)

<TABLE 1>

MATERIAL NO.	ORDER NO.	COLOR	PACKING	PACKING INFO.
1040040901	104004-0901	BLACK	TRAY	PK-104004-003
1040040902	104004-0902	BLACK	ST TRAY	PK-104004-004
1040040903	104004-0903	BLACK	EMBOSS	PK-104004-005

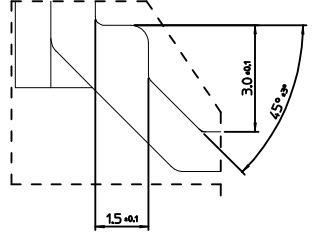

<PARTS LIST>

NO.	PART NAME	MATERIAL
1	SHROUD-A	LCP, GLASS FILLED, UL94 V-0
2	RECEPTACLE HOUSING	LCP, GLASS FILLED, UL94 V-0
3	CONTACT HOUSING	LCP, GLASS FILLED, UL94 V-0
4	CONTACT TERMINAL	COPPER ALLOY
5	SHIELD CASE	PHOSPHOR BRONZE
6	BOARD LOCKS PIN	BRASS

REVISED
EC NO: KTR2015-0098
DRAWN: IBAEK 2015/04/27
CHKD:
APPR: JYCHOI 2015/05/04
REV DESCRIPTION

QUALITY SYMBOLS
▽=0
▽=0

GENERAL TOLERANCES (UNLESS SPECIFIED)
mm INCH
4 PLACES ± --- ± ---
3 PLACES ± --- ± ---
2 PLACES ± 0.15 ± ---
1 PLACE ± 0.25 ± ---
ANGULAR ± 1°

DRAFT WHERE APPLICABLE
MUST REMAIN WITHIN DIMENSIONS

DIMENSION STYLE
MM ONLY

DRAWN BY DATE
S.M.KIM 2009/06/17

CHECKED BY DATE
B.C.YOON 2009/06/17

APPROVED BY DATE
JYCHOI 2013/01/07

MATERIAL NO.
SEE TABLE 1

SCALE
5:1

DESIGN UNITS
METRIC

THIRD ANGLE PROJECTION

TITLE
USCAR USB MINI B CONN
VERTICAL A
(LONG TERMINAL VERSION)

MOLEX INCORPORATED

DOCUMENT NO.
SD-104004-006

SHEET NO.
1 OF 2

SIZE
THIS DRAWING CONTAINS INFORMATION THAT IS PROPRIETARY TO MOLEX INCORPORATED AND SHOULD NOT BE USED WITHOUT WRITTEN PERMISSION

7 6 5 4 3 2 1

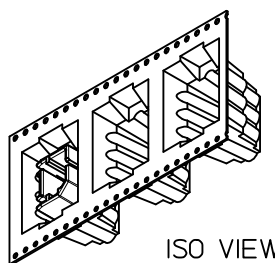

ISO VIEW

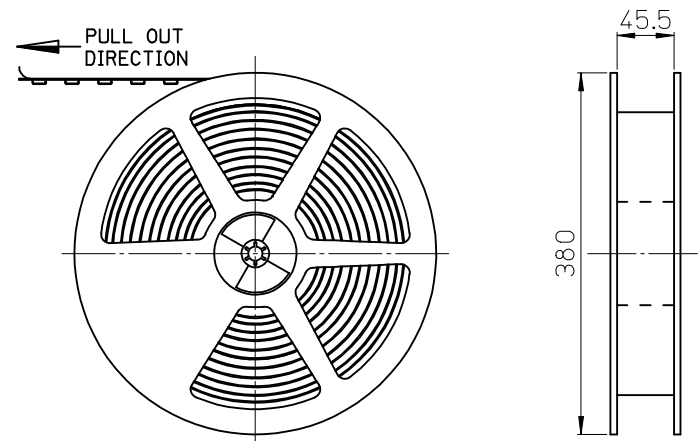
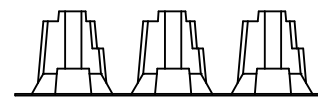

PLASTIC BOBBIN

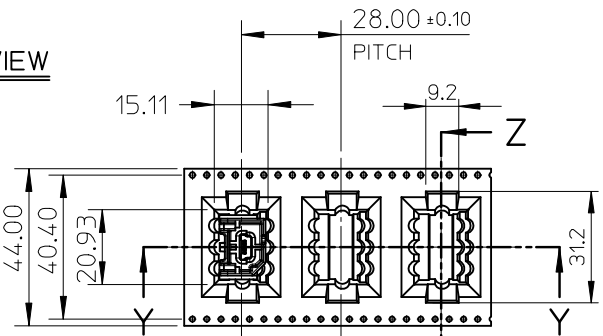
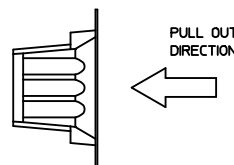

EMBOSS TAPE

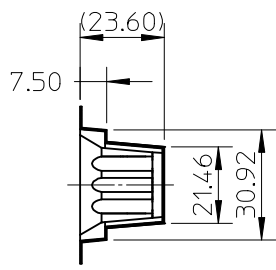

SECTION Z-Z

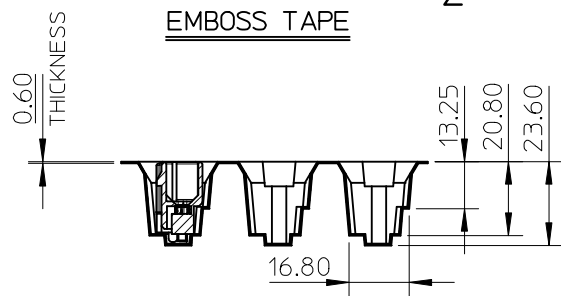

SECTION Y-Y

NOTES

- QUANTITY OF CONNECTORS: 120EA/REEL
- MATERIAL
 - PLASTIC BOBBIN : PS
 - CARRIER TAPE : P.E.T ANTI-STATIC
- LEAD LENGTH
- PEELING OFF FORCE OF COVER TAPE : 0.1N~0.59N(10.2GF~60GF)
 (PEELING DIRECTION AS SHOW IN FOLLOW FIG.)
 PEELING OFF SPEED : 300mm/Min.(Ref.)

5. FLASH IN ANY PORTION SHOULD BE LESS THAN 0.20mm MAX.

ADDED OPTION EC NO: KTR2015-0089 DRWN:Y1BAEK 2015/04/18 CHKD: APPR:JYCHO1 2015/04/27	DESCRIPTION REV	QUALITY SYMBOLS	GENERAL TOLERANCES (UNLESS SPECIFIED)		DIMENSION STYLE	SCALE	DESIGN UNITS	THIRD ANGLE PROJECTION
		$F=0$ $F=0$ $F=0$			MM ONLY	1:2	METRIC	
			4 PLACES	± ---	± ---	DRAWN BY	DATE	TITLE
			3 PLACES	± ---	± ---	Y1BAEK	2015/04/18	USCAR USB MINI B CONN VERTICAL A (LONG TERMINAL VERSION)
			2 PLACES	± 0.15	± ---	CHECKED BY	DATE	
1 PLACE	± 0.25		± ---	APPROVED BY	DATE	molex		
0 PLACE	± ---	± ---	JYCHO1	2015/04/27				
ANGULAR ± 1 ° DRAFT WHERE APPLICABLE MUST REMAIN WITHIN DIMENSIONS			MATERIAL NO.	SEE TABLE		DOCUMENT NO.	SHEET NO.	
			SIZE	THIS DRAWING CONTAINS INFORMATION THAT IS PROPRIETARY TO MOLEX INCORPORATED AND SHOULD NOT BE USED WITHOUT WRITTEN PERMISSION		SD-104004-006	2 OF 2	

6 5 4 3 2 1