

This document is the property of Amphenol Corporation and is delivered on the express condition that it is not to be disclosed, reproduced or used, in whole or in part, for manufacture or sale by anyone other than Amphenol Corporation without its prior consent, & that no right is granted to disclose or to use any information in this document.

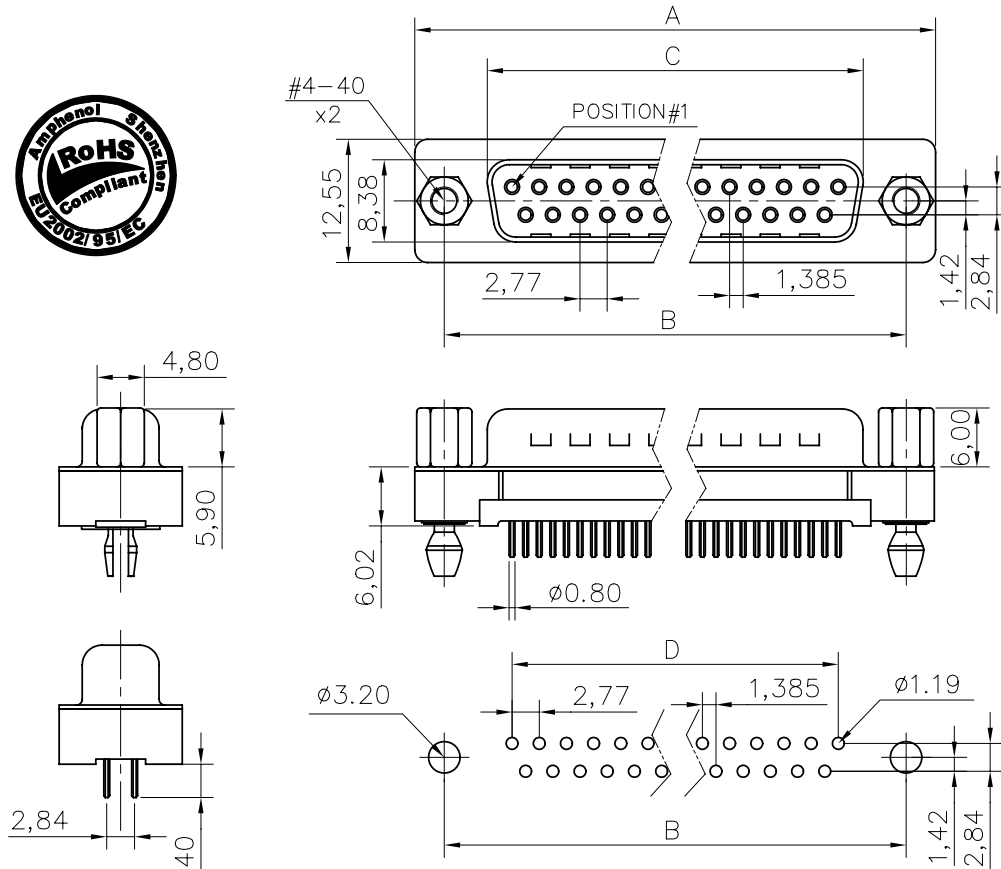

RECOMMENDED P.C.B LAYOUT
(TOLERANCE +/-0.03)

Customer drawing

DIM.S				
	SHELL	A	B	C
09	30.84	24.99	16.92	11.08
15	39.24	33.32	25.25	19.39
25	53.04	47.04	38.96	33.24
37	69.34	63.50	55.42	49.86

REVISIONS				
SYM	ECN	DESCRIPTION	DATE	APPROVED
1			05/27/08	

D-SUB TECHNICAL DATA

SHELL : Steel 2.5um(100u") min tin over 1.25um(50u") min nickel
 BODY : Glass filled thermoplastic.
 Flame retardant to UL94 V-0 Color Black
 CONTACTS : Brass
 Gold flash over 1.25um(50u") min. nickel
 BOARDLOCK : Brass,100u" min. tin over 50u" min. nickel
 SCREWLOCK : Brass,100u" min. tin over 50u" min. nickel
 ELECTRICAL : Voltage rating : 600 V RMS at 50 Hz
 Current rating : 5A.
 Insulation resistance >5000 M Ohms
 Contact resistance 20mOhms max.
 CLIMATIC : Temperature range -55 °C up to 125°C
 Damp heat 21 days(40 °C-95% HR)
 MARKING : Amphenol-...(Series No.)
 Commercial reference
 Manufacturing date

PRODUCT CODE

L 717TS X H XX P OL2 RM8

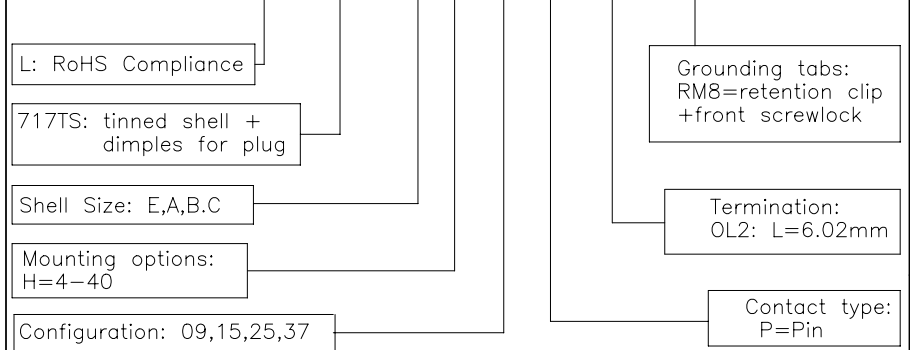

UNLESS OTHERWISE SPECIFIED TOLERANCES		APPROVAL	DATE
	U.S.		
.X	+/-	DRAWN	Christina.cui 05/27/08
.XX	+/-	CHECKED	Hk.wang 05/27/08
.XXX	+/-	CHECKED	
FRACTIONS	+/-		
ANGLES	+/-		
FOR MATERIALS AND FINISHES SEE NOTES		DRAWING FILE :	
REMOVE SHARP EDGES		ANGLE OF PROJECTION	
DIMENSIONS			
U.S.	INCHES		
METRIC	MM		

Amphenol®		
TITLE D-SUB connectors, TS series		
SIZE	DRAWING NO.	REV.
A4	C L717TSXHXXPOL2RM8	1
SCALE	NONE	SHEET 1 OF 1