

# User's Guide

## MCT8329EVM Evaluation Module

---



### ABSTRACT

This document is provided with the MCT8329 customer evaluation module (EVM) as a supplement to the MCT8329 data sheet ([MCT8329 Three-Phase Sensorless-Trapezoidal BLDC Gate Driver](#)). This user's guide details the hardware implementation of the EVM and how to setup and power the board.

---

### Table of Contents

<b>1 Cautions and Warnings</b> .....	2
<b>2 Introduction</b> .....	2
<b>3 Quick Start Guide</b> .....	3
<b>4 Hardware and Software Overview</b> .....	4
4.1 Hardware Connections Overview – MCT8329EVM.....	4
4.2 Connection Details.....	5
4.3 MSP430FR2355 Microcontroller & User Interface.....	6
4.4 LED Lights.....	7
4.5 User-Configurable Settings.....	8
<b>5 Hardware Setup</b> .....	10
<b>6 MCT8329 GUI Application</b> .....	11
6.1 Running the GUI.....	11
6.2 Offline Installer.....	11
<b>7 MSP430FR2355 Interface Firmware</b> .....	12
7.1 Downloading Code Composer Studio and Importing MSP430FR2355 Interface Firmware Code.....	12
7.2 Using the eZ-FET to Program the MSP430FR2355.....	13
<b>8 Schematics</b> .....	14
8.1 Main Supply.....	14
8.2 Connectors and Interface.....	14
8.3 USB to UART.....	14
8.4 MCU Programming and Debug.....	15
8.5 MSP430FR2355 MCU.....	15
8.6 MCT8329 3-Phase Sensorless Trapezoidal Gate Driver.....	16
8.7 Status LEDs.....	16
8.8 Switches and Speed Input.....	17
<b>9 Revision History</b> .....	18

### Trademarks

LaunchPad™ is a trademark of Texas Instruments.  
All trademarks are the property of their respective owners.

## 1 Cautions and Warnings

Observe the following cautions and warnings as printed on the EVM board.



### CAUTION

Hot Surface! Contact can cause burns. Do not touch. Please take the proper precautions when operating.

## 2 Introduction

The MCT8329 is a 4.5-V to 60-V, three-phase BLDC gate driver IC with code-free sensorless Trapezoidal control for motor drive applications. The MCT8329 provides three half-bridge gate drivers, each capable of driving highside and low-side N-channel power MOSFETs. The device generates the correct gate drive voltages using an internal charge pump and enhances the high-side MOSFETs using a bootstrap circuit. A trickle charge pump is included to support 100% duty cycle. The Gate Drive architecture supports peak gate drive currents up to 1-A source and 2-A sink. The MCT8329 can operate from a single power supply and supports a wide input supply range of 4.5 to 60 V. The I2C interface variant (MCT8329A11) also provides a standard I2C interface for configuring the various device settings and reading fault diagnostic information through an external controller.

The MCT8329EVM includes an onboard FTDI chip to convert USB communication from the micro-USB connector into UART and an onboard MSP430FR2355 MCU to interface with the MCT8329. The MCT8329EVM can also provide SPI communication for the SPI variant of the MCT8329 device. There are many user-selectable jumpers, resistors, connectors, and test points to evaluate many features of the device and configure device-specific settings.

This document serves as a startup guide to supplement the MCT8329EVM. The user's guide is intended for engineers to design, implement, and validate reference hardware for the MCT8329 device.

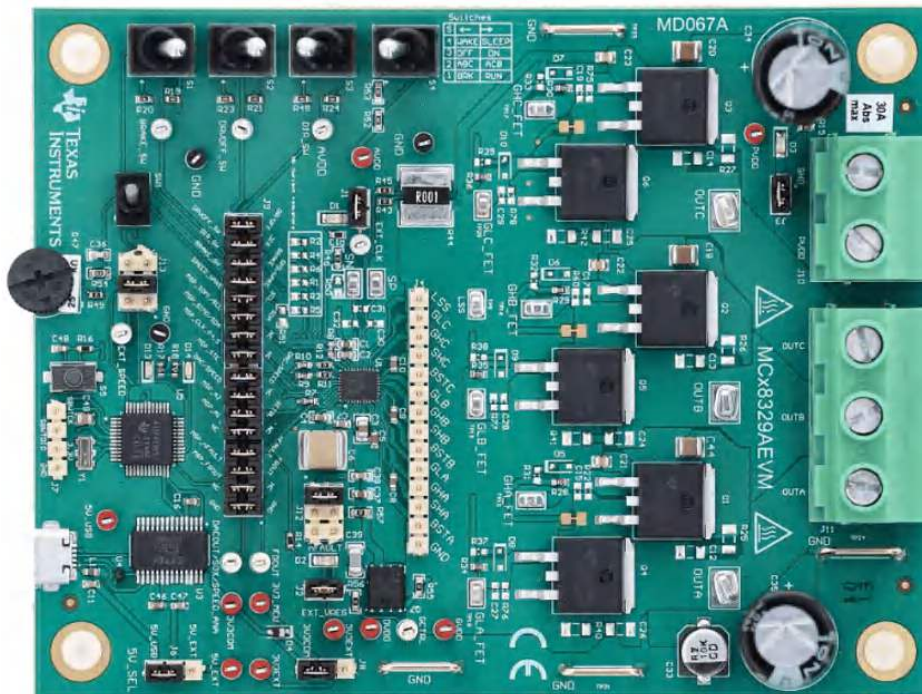

Figure 2-1. MCT8329EVM Printed Circuit Board (PCB - Top View)

### 3 Quick Start Guide

The MCT8329EVM requires a power supply source, which has a recommended operating range from a 4.5-V to 60-V. To setup and power the EVM, follow the sequence below:

1. Connect motor phases to A, B, C on connector J11.
2. Do not turn on the power supply yet. Connect motor supply to PVDD and GND on connector J10.
3. Select J6 to 5V\_USB and J8 to 3V3COM to power MSP430 from USB power supply.
4. Connect the micro-USB cable into the computer.
5. Turn the potentiometer fully clockwise to set the motor to zero speed upon powerup.
6. Flip the switch S1 to the top to configure BRAKE = RUN, switch S2 to the top to configure DRVOFF = ON, switch S3 to the bottom to configure DIR = ABC, and switch S4 to the bottom to configure to WAKE.
7. Flip the switch SW1 to left to configure SPEED/WAKE pin to SPEED mode and DACOUT/SOx/SPEED\_ANA pin to DACOUT mode. Note that flipping the switch SW1 to right configures SPEED/WAKE pin to WAKE mode and DACOUT/SOx/SPEED\_ANA pin to SPEED\_ANA mode. When SW1 is flipped to right, switch S4 can be used to put the device in SLEEP or WAKE mode and potentiometer R47 can be used to apply analog voltage to the DACOUT/SOx/SPEED\_ANA pin.
8. Select J12 to leftmost position(closer to C6) to apply AVDD to VREG.
9. Select J13 to middle position to apply analog voltage from potentiometer R47 to SPEED/WAKE pin.
10. Turn on the motor power supply.
11. Use the potentiometer R47 to control the speed of the motor and the switches to disable the motor driver, change the direction, or apply a brake to the motor. Optionally, use the GUI (as shown in [Section 6](#)) to monitor real-time speed of the motor, put the MCT8329 into a low-power sleep mode, and read status of the LEDs.

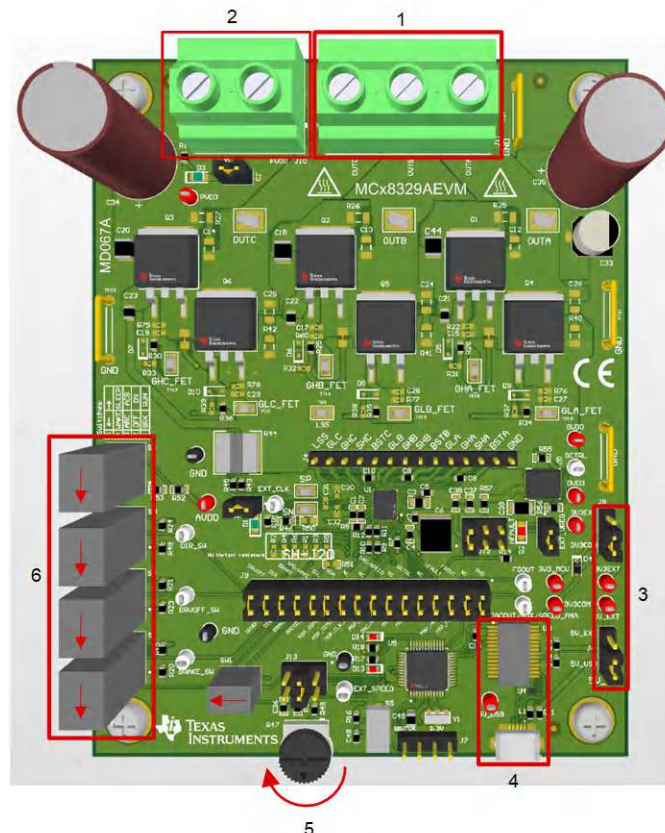
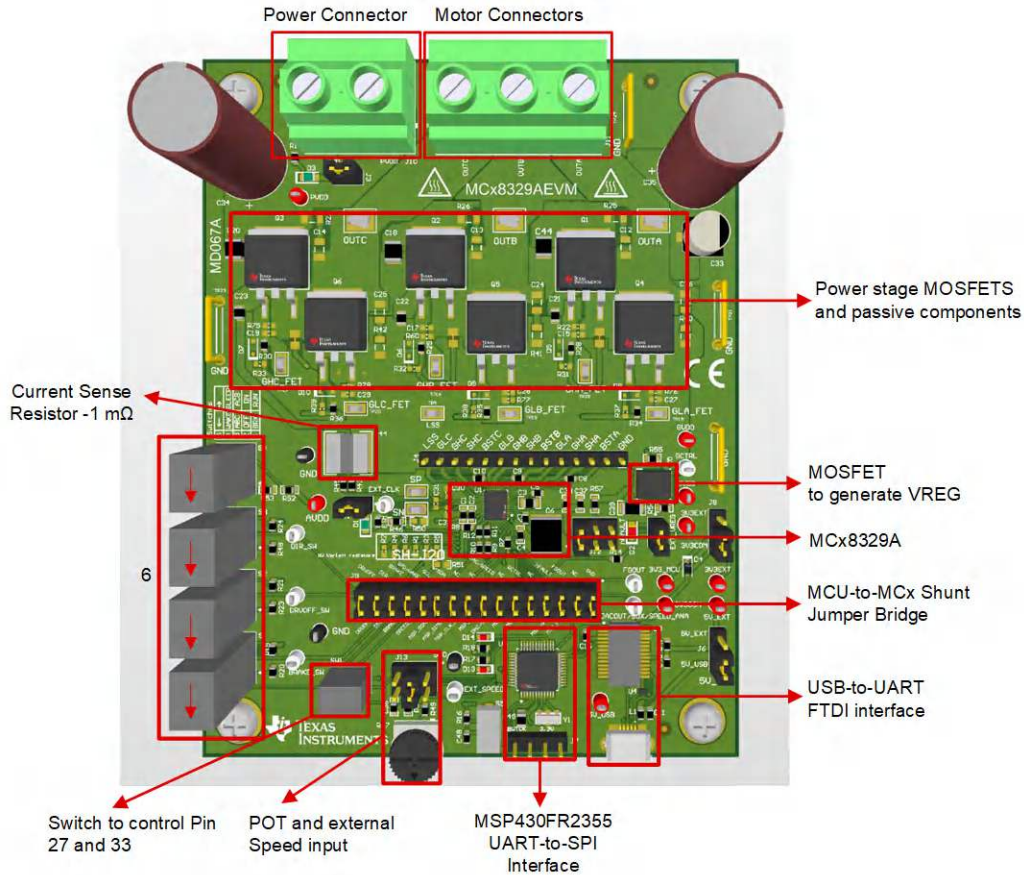

Figure 3-1. Reference for Quick Start Guide

## 4 Hardware and Software Overview

### 4.1 Hardware Connections Overview – MCT8329EVM

Figure 4-1 shows the major blocks of MCT8329EVM evaluation module. The MCT8329EVM is designed for an input supply from 4.5-V to 60-V. The MCT8329EVM includes power stage with six external N-channel power MOSFETs (Part number: CSD18536KTTT) and passive components. The MCT8329EVM also includes a current sense shunt resistor of 1 mΩ and an external N-channel MOSFET controlled by GCTRL to generate VREG. The MCT8329EVM also includes a current sense shunt resistor of 1 mΩ and an external N-channel MOSFET controlled by GCTRL to generate VREG.



**Figure 4-1. MCT8329EVM Major Hardware Blocks**

## 4.2 Connection Details

Figure 4-2 shows the connections made to the MCT8329EVM to spin a 3-phase sensorless Brushless-DC motor.

An 4.5-V to 60-V power supply is connected to the PVDD and GND terminals on connector J10.

The three phases of the BLDC motor connect directly to the A, B, and C terminals of the screw terminal connector J11 provided on the MCT8329EVM.

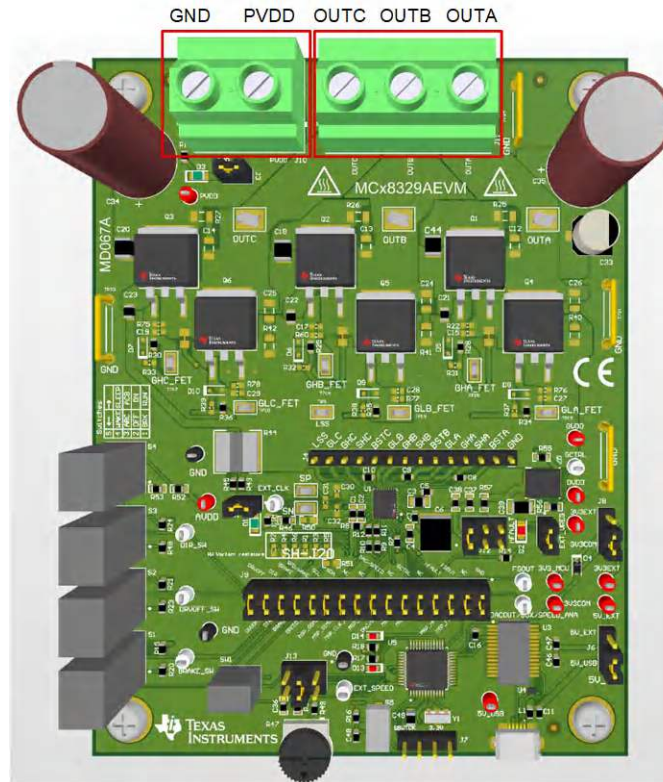

**Figure 4-2. Connections from Motor to MCT8329EVM**

Figure 4-3 MSP430FR2355 Microcontroller shows where the micro-USB cable is plugged into the MCT8329EVM to provide communication between evaluation module and GUI. The USB data and 5 V power from the USB is converted into UART data and 3.3 V power to power the MSP430FR2355 microcontroller. The 5 V from the USB power is limited to 500 mA and the 3.3 V from the FTDI chip is limit to 30 mA. If the user wants to supply more current to these rails, then use the 5V\_SEL jumper J3 and 3V3\_SEL jumper J5 to connect external power rails.

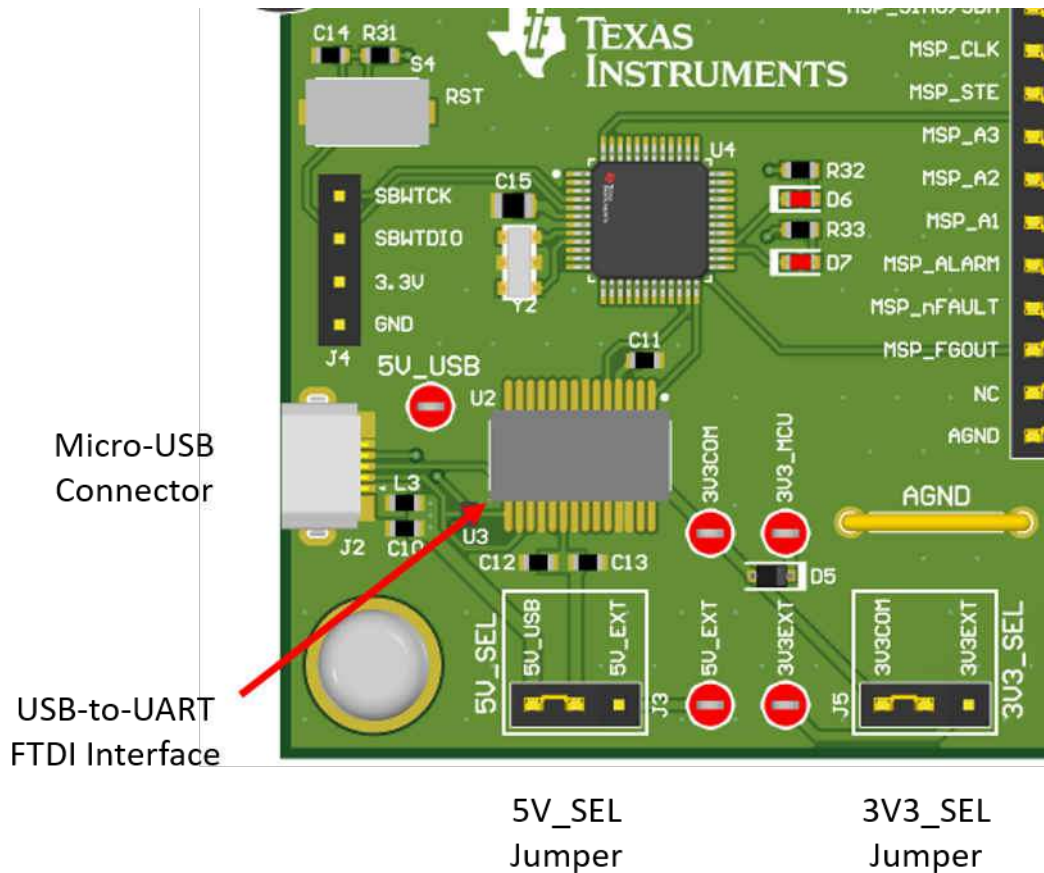

Figure 4-3. Micro-USB Connector and UART for MCT8329EVM

### 4.3 MSP430FR2355 Microcontroller & User Interface

The MCT8329EVM includes the MSP430FR2355 low-power MCU (as shown in Figure 4-4) to communicate via I2C with the MCT8329.

To program the MSP430FR2355, an external MSP430 FET programmer must be connected to the Spy-Bi-Wire (SBW) interface connector J4. Many MSP430 LaunchPad™ provide an onboard eZ-FET Debug Probe that can be jumper-wired to the MCT8329EVM to flash the firmware into the MSP430FR2355 microcontroller.

The user can use the Reset (RST) button at any time to reset and restart the MCU program. Two active-low LEDs, D13 and D14, can be used for debug purposes as well.

Finally, a shunt jumper bridge on the 32-pin connector J9 ties all signals between the microcontroller and MCT8329. These jumpers can be inserted or removed as needed to isolate the microcontroller from the gate driver. This allows for microcontroller signal debugging or using the MCT8329EVM as a standalone gate driver with an external microcontroller.

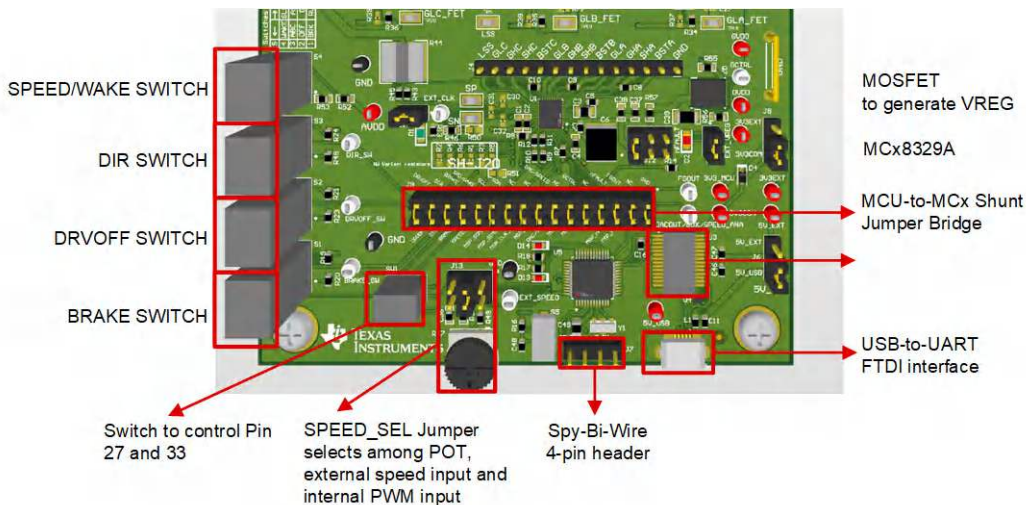

Figure 4-4. MSP430FR2355 MCU and User Interface on MCT8329EVM

#### 4.4 LED Lights

The MCT8329EVM has 5 status LEDs implemented that provide the status of power supplies and functions of the evaluation module. By default, the VM LED and 3.3 V Buck LEDs light up when the board is powered and the program has been flashed onto the microcontroller. Table 4-1 shows LED descriptions including those that are on during power up in bold and Figure 4-5 shows the locations of the LEDs.

Table 4-1. Description of MCT8329EVM LEDs (default in bold after powerup)

Designator	Name	Color	Description
D1	<b>AVDD Regulator</b>	<b>Green</b>	<b>Lights up when AVDD is turned ON.</b>
D2	nFAULT	Red	Lights up when fault condition has occurred on MCT8329
D3	<b>PVDD</b>	<b>Green</b>	<b>Lights up when voltage is applied on PVDD.</b>
D13	<b>MSP_LED1</b>	<b>Red</b>	<b>Used for UART or debugging</b>
D14	MSP_LED2	Red	Used for UART or debugging

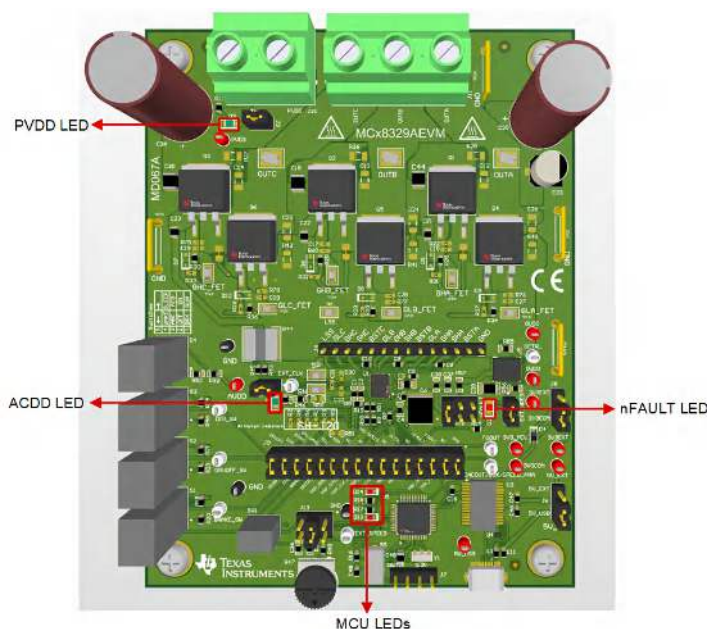

Figure 4-5. MCT8329EVM LEDs

## 4.5 User-Configurable Settings

The MCT8329EVM includes a variety of user-selectable jumpers, switches, and resistors on the entirety of the evaluation board to configure settings. [Table 4-2](#) summarizes all of these configurable settings.

**Table 4-2. Description of User-Selectable Settings on MCT8329EVM (Default in Bold)**

Designator	Setting Name	Description	Layer	Position	Function
J8	3V3_SEL	Select 3.3 V for MCU power	Top	J8 = 3V3EXT	External
				<b>J8 = 3V3COM</b>	<b>From FTDI (30 mA)</b>
J6	5V_SEL	Select 5 V for FTDI power	Top	J6 = 5V_EXT	External
				<b>J6 = 5V_USB</b>	<b>From USB power (500 mA)</b>
J13	SPEED_SEL	Selects SPEED input source	Top	J13 = EXT	External EXT_SPEED test point
				<b>J13 = POT</b>	<b>From Potentiometer R47.</b>
				J13 = INT_PWM	From internal PWM. PWM Duty cycle can be varied by rotating the POT R47.
J9	MSP to MCx Shunt jumper bridge	Connects signals from MCU and user switches to MCT8329 when jumpers are inserted	Top	<b>DRVOFF_SW</b>	<b>DRVOFF</b>
				<b>DIR_SW</b>	<b>DIR</b>
				<b>BRAKE_SW</b>	<b>BRAKE</b>
				<b>SPEED_WAKE</b>	<b>SPEED/WAKE</b>
				<b>MSP_POCI/SCL</b>	<b>SCL</b>
				<b>MSP_PICO/SDA</b>	<b>SDA</b>
				<b>MSP_CLK</b>	<b>NC</b>
				<b>MSP_STE</b>	<b>NC</b>
				<b>DAC/SPEED</b>	<b>DAC/SPEED</b>
				<b>MSP_A2</b>	<b>NC</b>
				<b>MSP_A1</b>	<b>GCTRL</b>
				<b>NC</b>	<b>NC</b>
				<b>MSP_nFAULT</b>	<b>nFAULT</b>
				<b>MSP_FGOUT</b>	<b>FGOUT</b>
<b>NC</b>	<b>NC</b>				
<b>GND</b>	<b>GND</b>				
J12	VREG_SEL	Selects VREG power supply	Top	<b>Left position</b>	<b>VREG powered by AVDD</b>
				Middle position	VREG powered externally.
				Right position	VREG powered by MOSFET Q7
J1	AVDD LED	Connects AVDD LED to 3.3 V pull up.	Top	<b>Connected</b>	<b>D1 lights up when AVDD is turned ON.</b>
J2	nFAULT LED	Connects nFAULT LED to 3.3 V pull up.	Top	<b>Connected</b>	<b>D2 lights up when nFAULT is Pulled low.</b>
J3	PVDD LED	Connects PVDD LED to 3.3 V pull up.	Top	<b>Connected</b>	<b>D3 lights up when voltage is applied to PVDD.</b>
S1	BRAKE	Turns on all low-side MOSFETs	Top	Bottom	Brake enabled
				<b>Top</b>	<b>Brake disabled</b>



**Table 4-2. Description of User-Selectable Settings on MCT8329EVM (Default in Bold) (continued)**

Designator	Setting Name	Description	Layer	Position	Function
S2	DRVOFF	Disables gate drivers	Top	Bottom	MCT8329 disabled
				<b>Top</b>	<b>MCT8329 enabled</b>
S3	DIR	Controls direction of motor rotation.	Top	<b>Bottom</b>	<b>ABC</b>
				Top	ACB
S4	SPEED/WAKE	Pulls SPEED/WAKE pin to AVDD and GND	Top	<b>Bottom</b>	<b>SPEED/WAKE pin pulled to AVDD.</b>
				Top	SPEED/WAKE pin pulled to GND.
SW1	N/A	Configure SPEED/WAKE pin to SPEED mode and DACOUT/SOx/ SPEED_ANA pin	Top	<b>Left</b>	<b>Configure SPEED/WAKE pin to SPEED mode and DACOUT/SOx/ SPEED_ANA pin to DACOUT mode.</b>
				Right	Configure SPEED/WAKE pin to WAKE mode and DACOUT/SOx/ SPEED_ANA pin to SPEED_ANA mode.

## 5 Hardware Setup

The hardware required to run the motor is the MCT8329EVM, a Micro-USB cable, and a power supply with a DC output from 4.5-V to 60-V. Follow these steps to start up the MCT8329EVM:

1. Connect the DC power supply to header J10. Connect to PVDD and GND.
2. Apply user configurable jumper settings. See [Section 4.5](#) section for more information.
3. Flash program into the MCU as described in [Section 4](#). Launch the GUI in GUI Composer and disconnect the 4-pin JTAG connections.
4. Connect a Micro-USB cable to the MCT8329EVM and computer.
5. Turn on the power supply and power up the PCB.

If using the MCT8329EVM with an external microcontroller, remove all shunt jumpers from jumper bridge J9. Connect with external jumpers to the left side of the jumper bridge from the external MCU.

## 6 MCT8329 GUI Application

The MCT8329EVM includes a USB-UART interface, using a MSP430FR2355 microcontroller, that serves as a communication bridge between a host PC and the MCT8329 device for configuring various device settings and reading fault diagnostic information. A MCT8329 GUI is available to interface with and configure the MCT8329 using this communication interface.

Access the [MCT8329A GUI](#) through the TI Cloud Gallery.

### 6.1 Running the GUI

The MCT8329A GUI can be run directly inside a web browser (supported in Google Chrome and Firefox).

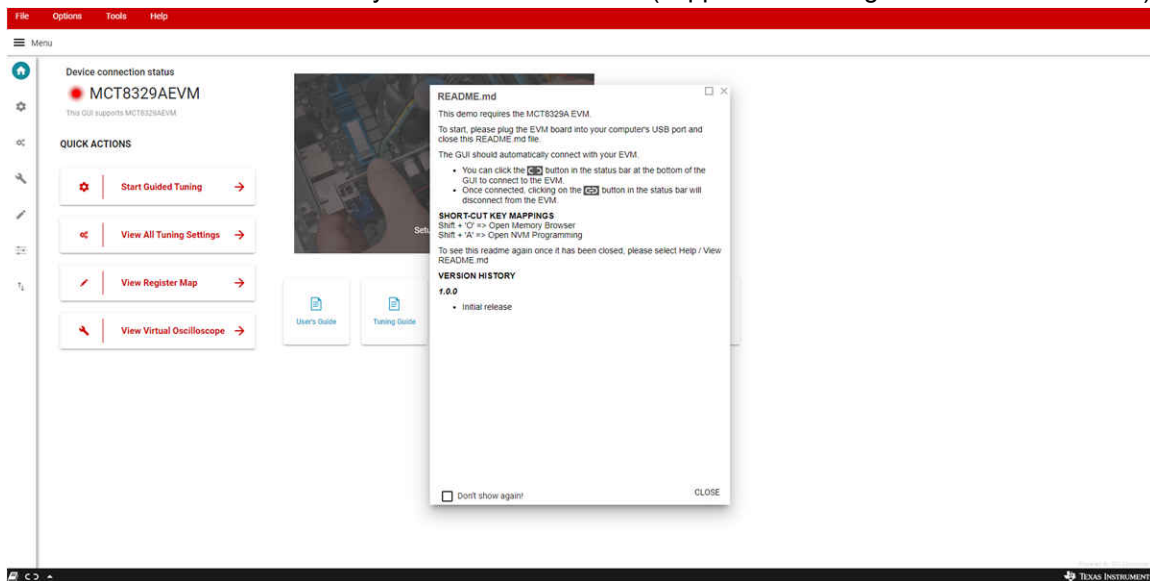

**Figure 6-1. MCT8329A GUI**

Once the GUI is loaded, follow the step-by-step Guided Tuning section of the GUI to configure the device.

### 6.2 Offline Installer

Alternatively, the MCT8329A GUI can be downloaded and installed offline using the download feature in the TI Cloud Gallery. Here are the steps to install MCT8329A GUI offline:

1. Go to [dev.ti.com/gallery](https://dev.ti.com/gallery) and search for *MCT8329*.
2. Place the cursor on the download (down arrow) button.
3. Select the appropriate operating system (Linux, MAC or Windows) and click the operating system. (Note: Do not click the runtime)
4. A zip file starts to download. Unzip the file and click the .exe file to install the offline MCT8329A GUI.

## 7 MSP430FR2355 Interface Firmware

The MSP430FR2355 on the MCT8329EVM comes pre-programmed with the firmware necessary for communicating with the PC GUI and the MCT8329. In order to reprogram or flash custom code on the MSP430FR2355, you will need an external MSP430 LaunchPad™ that includes the eZ-FET Debug Probe. In this example, we use the [MSP-EXP430FR2355 LaunchPad Development Kit](#) to provide the debug probe. Follow the steps below to download the code for the MCT8329EVM to use with the GUI.

### 7.1 Downloading Code Composer Studio and Importing MSP430FR2355 Interface Firmware Code

1. Extract the “MCT8329EVM\_MSP430FR2355\_Firmware\_GUI.zip” to a location on the computer.
2. Download the latest version of [Code Composer Studio](#). This download sets up a ti folder in the directory C:\ti.
  - a. Accept all agreements, default install locations, and hit *Next* to proceed through menus.
  - b. In the *Select Components* window, make sure to check *MSP430 Low-Power MCUs* to install the required packages for the MSP430 LaunchPad Evaluation Kits.
3. After installing, run CCS and select a folder or the default to use as the Workspace to store any new projects. The location and naming convention can be changed based on the user's preference. Click the OK button to accept.
4. In CCS, click on the Project tab and select *Import CCS Projects*. Click on *Browse*.
5. Select the *MCT8329EVM\_MSP430FR2355\_Firmware\_GUI* folder installed from step 1.
6. Import the project *MCT8329EVM\_MSP430FR2355\_Firmware\_GUI* into your workspace as shown in [Figure 7-1](#).

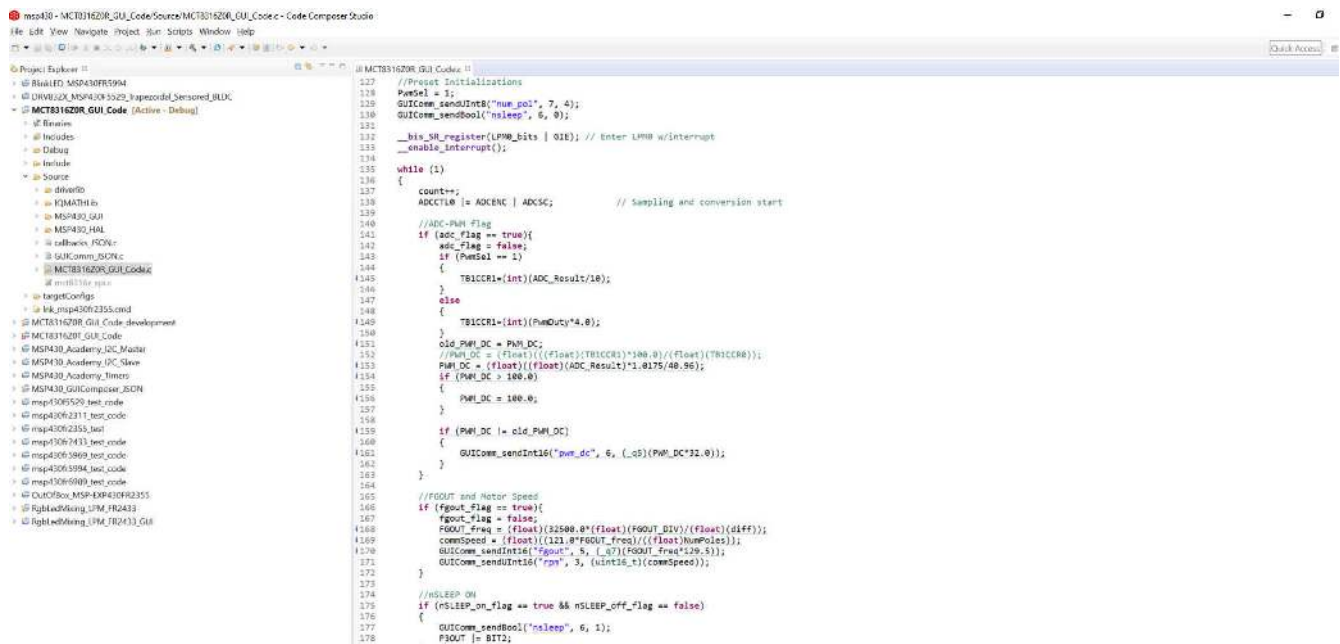

```

127 //Preset Initializations
128 PwMsel = 1;
129 GUIComm_sendInt16("num_poles", 7, 4);
130 GUIComm_sendBool("nsleep", 6, 0);
131
132
133 __bis_SR_register(LPM0_bits | 0x1E); // Enter LPM0 w/interrupt
134 __enable_interrupt();
135
136 while (1)
137 {
138     count++;
139     ADCCTL0 |= ADCENC | ADCSC; // Sampling and conversion start
140
141     //ADC-PWM Flag
142     if (adc_flag == true){
143         adc_flag = false;
144         if (PwMsel == 1)
145         {
146             TBCCR1=(int)(ADC_Result/10);
147         }
148         else
149         {
150             TBCCR1=(int)(PwmDuty*4.0);
151         }
152         cld_PWM_DC = PWM_DC;
153         //PWM_DC = (float)((float)(TBCCR1)*100.0)/(float)(TBCCR0);
154         PWM_DC = (float)((float)(ADC_Result)*1.0175/40.00);
155         if (PWM_DC > 100.0)
156         {
157             PWM_DC = 100.0;
158         }
159         if (PWM_DC != cld_PWM_DC)
160         {
161             GUIComm_sendInt16("pwm_dc", 6, (int)(PWM_DC*32.0));
162         }
163     }
164
165     //FGOUT and Motor Speed
166     if (fgout_flag == true){
167         fgout_flag = false;
168         FGOUT_freq = (float)(32500.0*(float)(FGOUT_DIV)/(float)(diff));
169         commSpeed = (float)((121.8*FGOUT_freq)/((float)numPoles));
170         GUIComm_sendInt16("fgout", 5, (int)(FGOUT_freq*129.5));
171         GUIComm_sendInt16("rpm", 3, (int)(121.8*commSpeed));
172     }
173
174
175 //NSLEEP ON
176 if (nsleep_on_flag == true && nsleep_off_flag == false)
177 {
178     GUIComm_sendBool("nsleep", 6, 1);
179     P3OUT |= BIT2;
180 }

```

Figure 7-1. MSP430FR2355 Interface Firmware Code in Code Composer Studio

## 7.2 Using the eZ-FET to Program the MSP430FR2355

The eZ-FET Debug Probe on the MSP430FR2355 LaunchPad uses a SPI-by-Wire JTAG interface to program the MSP430FR2355 MCU on the MCT8329EVM. Consult the [MSP430 LaunchPad Development Kits](#) for MSP430 LaunchPads that include an onboard eZ-FET Debug Probe.

1. Remove the GND, 3V3, SBWTDIO, and SBWTCK jumpers from the MSP430 LaunchPad.
2. Connect the top pins on the eZ-FET side of the LaunchPad of the GND, 3V3, SBWTCK, and SBWTDIO signals to their respective pins on J7 of the MCT8329EVM as shown in [Table 7-1](#) and [Figure 7-2](#).
3. Connect a micro-USB cable to the MSP430 LaunchPad and the PC.
4. Click on the Build Project icon or *Ctrl + B* to verify that the project builds successfully. Accept any updates if needed from the Console.
5. Click on Debug Project to set up a debug session and press the Play button to run the code.
6. Stop the debug session, close Code Composer Studio, disconnect the SPI-by-Wire jumpers, and unplug the micro-USB cable from the MSP430 LaunchPad.

**Table 7-1. SPY-BI-Wire Connections Needed to Program MSP430FR2355**

MSP430 LaunchPad (eZ-FET Debug Probe Side) (J101)	MCT8329EVM 4-pin SPI-by-Wire Header (J7)
GND	GND
3V3	3.3 V
SBWTDIO	SBWTDIO
SBWTCK	SBWTCK

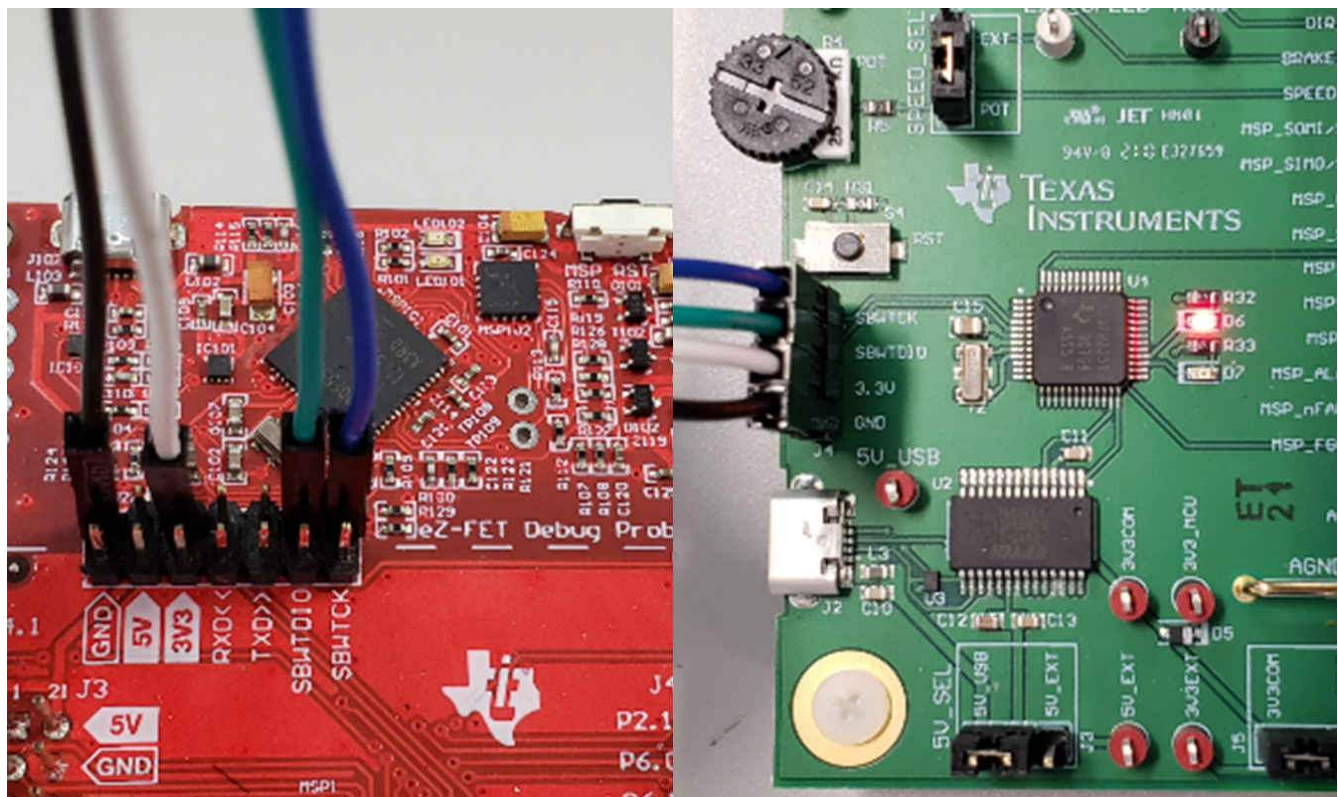

**Figure 7-2. MSP430 LaunchPad eZ-FET Probe Connected to MCT8329EVM**

## 8 Schematics

### 8.1 Main Supply

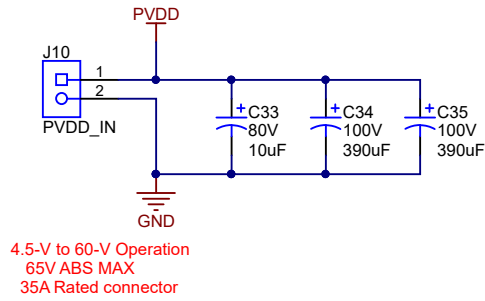

Figure 8-1. Main Supply

### 8.2 Connectors and Interface

### 8.3 USB to UART

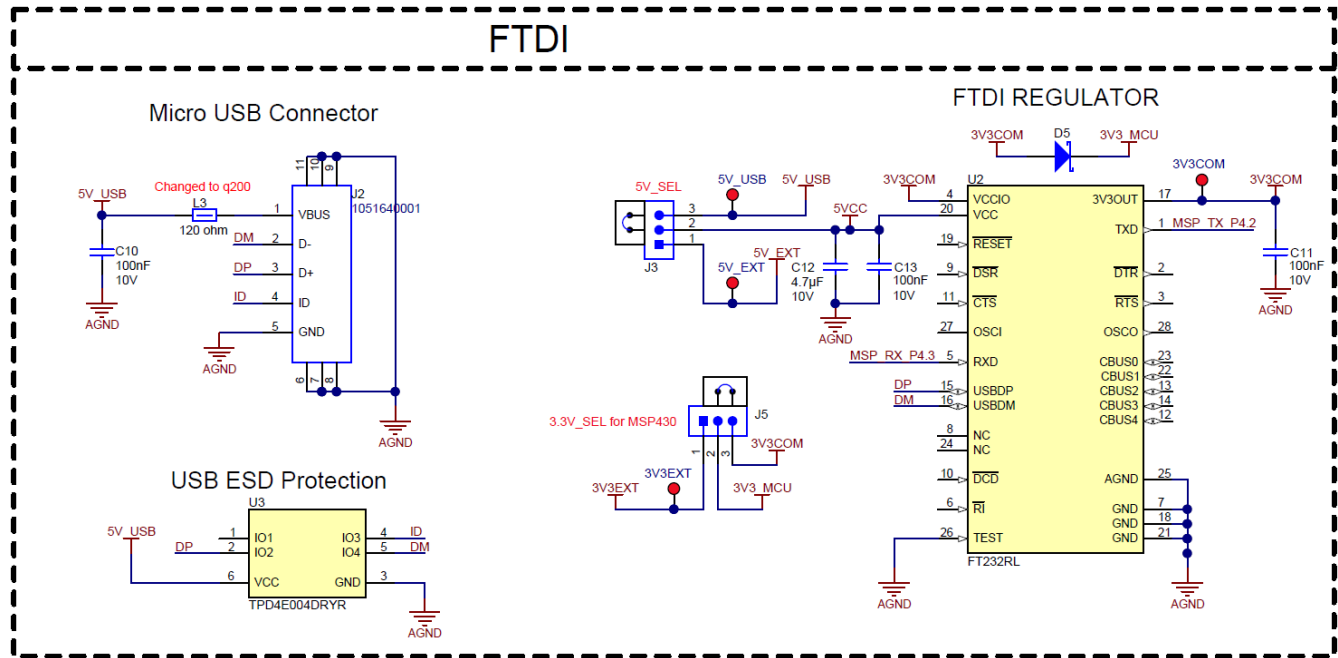

Figure 8-2. USB to UART Schematic



## 8.6 MCT8329 3-Phase Sensorless Trapezoidal Gate Driver

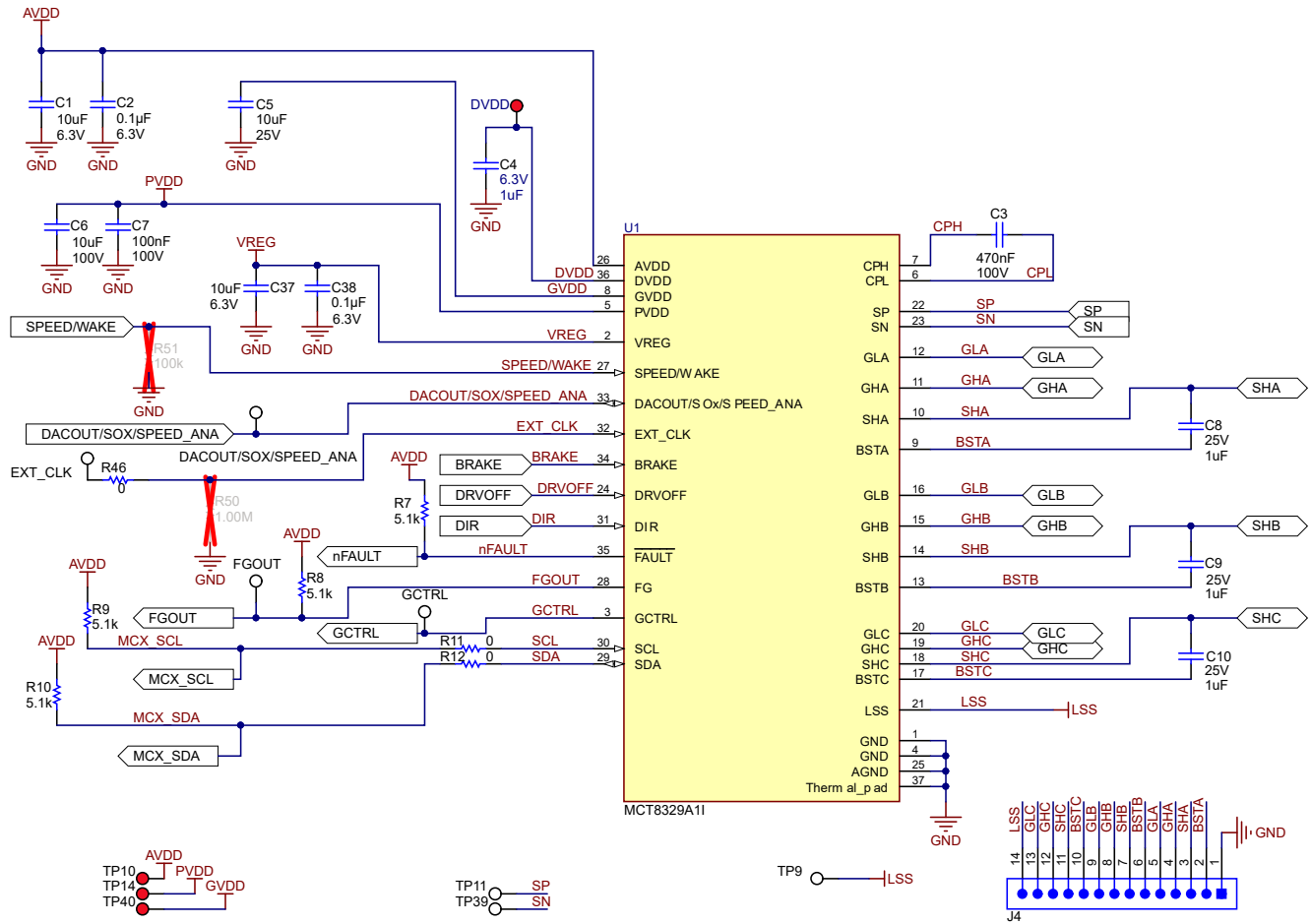

Figure 8-5. MCT8329A 3-Phase Sensorless Trapezoidal Gate Driver Schematic

## 8.7 Status LEDs

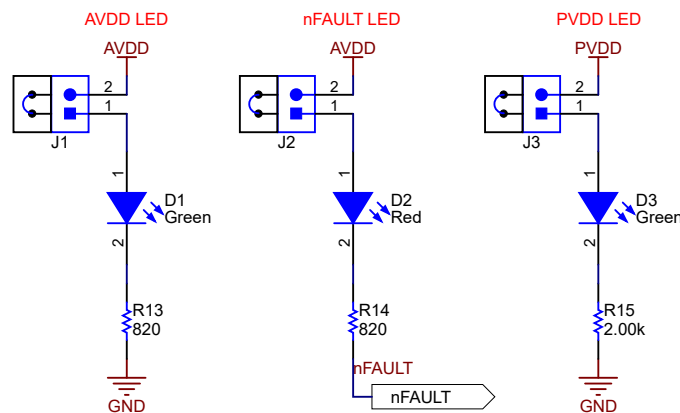

Figure 8-6. Status LEDs Schematic



## 8.8 Switches and Speed Input

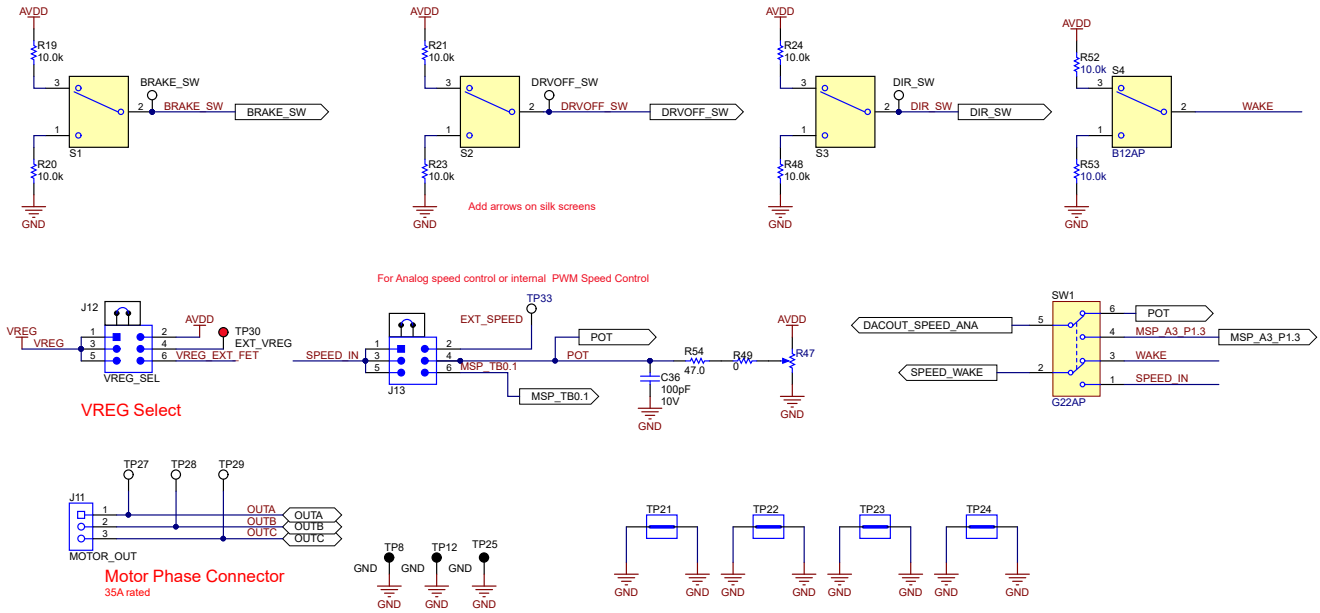

Figure 8-7. Switches and Speed Input

## 9 Revision History

NOTE: Page numbers for previous revisions may differ from page numbers in the current version.

<b>Changes from Revision * (December 2022) to Revision A (May 2023)</b>	<b>Page</b>
• Updated the quality of the images throughout the document.....	<a href="#">1</a>
• Changed all instances of legacy terminology to POCl and PICO where SPI is mentioned.....	<a href="#">8</a>

---

## STANDARD TERMS FOR EVALUATION MODULES

1. *Delivery:* TI delivers TI evaluation boards, kits, or modules, including any accompanying demonstration software, components, and/or documentation which may be provided together or separately (collectively, an "EVM" or "EVMs") to the User ("User") in accordance with the terms set forth herein. User's acceptance of the EVM is expressly subject to the following terms.
  - 1.1 EVMs are intended solely for product or software developers for use in a research and development setting to facilitate feasibility evaluation, experimentation, or scientific analysis of TI semiconductor products. EVMs have no direct function and are not finished products. EVMs shall not be directly or indirectly assembled as a part or subassembly in any finished product. For clarification, any software or software tools provided with the EVM ("Software") shall not be subject to the terms and conditions set forth herein but rather shall be subject to the applicable terms that accompany such Software
  - 1.2 EVMs are not intended for consumer or household use. EVMs may not be sold, sublicensed, leased, rented, loaned, assigned, or otherwise distributed for commercial purposes by Users, in whole or in part, or used in any finished product or production system.
2. *Limited Warranty and Related Remedies/Disclaimers:*
  - 2.1 These terms do not apply to Software. The warranty, if any, for Software is covered in the applicable Software License Agreement.
  - 2.2 TI warrants that the TI EVM will conform to TI's published specifications for ninety (90) days after the date TI delivers such EVM to User. Notwithstanding the foregoing, TI shall not be liable for a nonconforming EVM if (a) the nonconformity was caused by neglect, misuse or mistreatment by an entity other than TI, including improper installation or testing, or for any EVMs that have been altered or modified in any way by an entity other than TI, (b) the nonconformity resulted from User's design, specifications or instructions for such EVMs or improper system design, or (c) User has not paid on time. Testing and other quality control techniques are used to the extent TI deems necessary. TI does not test all parameters of each EVM. User's claims against TI under this Section 2 are void if User fails to notify TI of any apparent defects in the EVMs within ten (10) business days after delivery, or of any hidden defects with ten (10) business days after the defect has been detected.
  - 2.3 TI's sole liability shall be at its option to repair or replace EVMs that fail to conform to the warranty set forth above, or credit User's account for such EVM. TI's liability under this warranty shall be limited to EVMs that are returned during the warranty period to the address designated by TI and that are determined by TI not to conform to such warranty. If TI elects to repair or replace such EVM, TI shall have a reasonable time to repair such EVM or provide replacements. Repaired EVMs shall be warranted for the remainder of the original warranty period. Replaced EVMs shall be warranted for a new full ninety (90) day warranty period.

### **WARNING**

**Evaluation Kits are intended solely for use by technically qualified, professional electronics experts who are familiar with the dangers and application risks associated with handling electrical mechanical components, systems, and subsystems.**

**User shall operate the Evaluation Kit within TI's recommended guidelines and any applicable legal or environmental requirements as well as reasonable and customary safeguards. Failure to set up and/or operate the Evaluation Kit within TI's recommended guidelines may result in personal injury or death or property damage. Proper set up entails following TI's instructions for electrical ratings of interface circuits such as input, output and electrical loads.**

**NOTE:**

EXPOSURE TO ELECTROSTATIC DISCHARGE (ESD) MAY CAUSE DEGRADATION OR FAILURE OF THE EVALUATION KIT; TI RECOMMENDS STORAGE OF THE EVALUATION KIT IN A PROTECTIVE ESD BAG.

### 3 Regulatory Notices:

#### 3.1 United States

##### 3.1.1 Notice applicable to EVMs not FCC-Approved:

**FCC NOTICE:** This kit is designed to allow product developers to evaluate electronic components, circuitry, or software associated with the kit to determine whether to incorporate such items in a finished product and software developers to write software applications for use with the end product. This kit is not a finished product and when assembled may not be resold or otherwise marketed unless all required FCC equipment authorizations are first obtained. Operation is subject to the condition that this product not cause harmful interference to licensed radio stations and that this product accept harmful interference. Unless the assembled kit is designed to operate under part 15, part 18 or part 95 of this chapter, the operator of the kit must operate under the authority of an FCC license holder or must secure an experimental authorization under part 5 of this chapter.

##### 3.1.2 For EVMs annotated as FCC – FEDERAL COMMUNICATIONS COMMISSION Part 15 Compliant:

#### **CAUTION**

This device complies with part 15 of the FCC Rules. Operation is subject to the following two conditions: (1) This device may not cause harmful interference, and (2) this device must accept any interference received, including interference that may cause undesired operation.

Changes or modifications not expressly approved by the party responsible for compliance could void the user's authority to operate the equipment.

#### **FCC Interference Statement for Class A EVM devices**

*NOTE: This equipment has been tested and found to comply with the limits for a Class A digital device, pursuant to part 15 of the FCC Rules. These limits are designed to provide reasonable protection against harmful interference when the equipment is operated in a commercial environment. This equipment generates, uses, and can radiate radio frequency energy and, if not installed and used in accordance with the instruction manual, may cause harmful interference to radio communications. Operation of this equipment in a residential area is likely to cause harmful interference in which case the user will be required to correct the interference at his own expense.*

#### **FCC Interference Statement for Class B EVM devices**

*NOTE: This equipment has been tested and found to comply with the limits for a Class B digital device, pursuant to part 15 of the FCC Rules. These limits are designed to provide reasonable protection against harmful interference in a residential installation. This equipment generates, uses and can radiate radio frequency energy and, if not installed and used in accordance with the instructions, may cause harmful interference to radio communications. However, there is no guarantee that interference will not occur in a particular installation. If this equipment does cause harmful interference to radio or television reception, which can be determined by turning the equipment off and on, the user is encouraged to try to correct the interference by one or more of the following measures:*

- Reorient or relocate the receiving antenna.
- Increase the separation between the equipment and receiver.
- Connect the equipment into an outlet on a circuit different from that to which the receiver is connected.
- Consult the dealer or an experienced radio/TV technician for help.

#### 3.2 Canada

##### 3.2.1 For EVMs issued with an Industry Canada Certificate of Conformance to RSS-210 or RSS-247

#### **Concerning EVMs Including Radio Transmitters:**

This device complies with Industry Canada license-exempt RSSs. Operation is subject to the following two conditions:

(1) this device may not cause interference, and (2) this device must accept any interference, including interference that may cause undesired operation of the device.

#### **Concernant les EVMs avec appareils radio:**

Le présent appareil est conforme aux CNR d'Industrie Canada applicables aux appareils radio exempts de licence. L'exploitation est autorisée aux deux conditions suivantes: (1) l'appareil ne doit pas produire de brouillage, et (2) l'utilisateur de l'appareil doit accepter tout brouillage radioélectrique subi, même si le brouillage est susceptible d'en compromettre le fonctionnement.

#### **Concerning EVMs Including Detachable Antennas:**

Under Industry Canada regulations, this radio transmitter may only operate using an antenna of a type and maximum (or lesser) gain approved for the transmitter by Industry Canada. To reduce potential radio interference to other users, the antenna type and its gain should be so chosen that the equivalent isotropically radiated power (e.i.r.p.) is not more than that necessary for successful communication. This radio transmitter has been approved by Industry Canada to operate with the antenna types listed in the user guide with the maximum permissible gain and required antenna impedance for each antenna type indicated. Antenna types not included in this list, having a gain greater than the maximum gain indicated for that type, are strictly prohibited for use with this device.

### Concernant les EVMs avec antennes détachables

Conformément à la réglementation d'Industrie Canada, le présent émetteur radio peut fonctionner avec une antenne d'un type et d'un gain maximal (ou inférieur) approuvé pour l'émetteur par Industrie Canada. Dans le but de réduire les risques de brouillage radioélectrique à l'intention des autres utilisateurs, il faut choisir le type d'antenne et son gain de sorte que la puissance isotrope rayonnée équivalente (p.i.r.e.) ne dépasse pas l'intensité nécessaire à l'établissement d'une communication satisfaisante. Le présent émetteur radio a été approuvé par Industrie Canada pour fonctionner avec les types d'antenne énumérés dans le manuel d'usage et ayant un gain admissible maximal et l'impédance requise pour chaque type d'antenne. Les types d'antenne non inclus dans cette liste, ou dont le gain est supérieur au gain maximal indiqué, sont strictement interdits pour l'exploitation de l'émetteur.

#### 3.3 Japan

3.3.1 *Notice for EVMs delivered in Japan:* Please see [http://www.tij.co.jp/lstds/ti\\_ja/general/eStore/notice\\_01.page](http://www.tij.co.jp/lstds/ti_ja/general/eStore/notice_01.page) 日本国内に輸入される評価用キット、ボードについては、次のところをご覧ください。

<https://www.ti.com/ja-jp/legal/notice-for-evaluation-kits-delivered-in-japan.html>

3.3.2 *Notice for Users of EVMs Considered "Radio Frequency Products" in Japan:* EVMs entering Japan may not be certified by TI as conforming to Technical Regulations of Radio Law of Japan.

If User uses EVMs in Japan, not certified to Technical Regulations of Radio Law of Japan, User is required to follow the instructions set forth by Radio Law of Japan, which includes, but is not limited to, the instructions below with respect to EVMs (which for the avoidance of doubt are stated strictly for convenience and should be verified by User):

1. Use EVMs in a shielded room or any other test facility as defined in the notification #173 issued by Ministry of Internal Affairs and Communications on March 28, 2006, based on Sub-section 1.1 of Article 6 of the Ministry's Rule for Enforcement of Radio Law of Japan,
2. Use EVMs only after User obtains the license of Test Radio Station as provided in Radio Law of Japan with respect to EVMs, or
3. Use of EVMs only after User obtains the Technical Regulations Conformity Certification as provided in Radio Law of Japan with respect to EVMs. Also, do not transfer EVMs, unless User gives the same notice above to the transferee. Please note that if User does not follow the instructions above, User will be subject to penalties of Radio Law of Japan.

【無線電波を送信する製品の開発キットをお使いになる際の注意事項】 開発キットの中には技術基準適合証明を受けていないものがあります。技術適合証明を受けていないものご使用に際しては、電波法遵守のため、以下のいずれかの措置を取っていただく必要がありますのでご注意ください。

1. 電波法施行規則第6条第1項第1号に基づく平成18年3月28日総務省告示第173号で定められた電波暗室等の試験設備でご使用いただく。
2. 実験局の免許を取得後ご使用いただく。
3. 技術基準適合証明を取得後ご使用いただく。

なお、本製品は、上記の「ご使用にあたっての注意」を譲渡先、移転先に通知しない限り、譲渡、移転できないものとします。

上記を遵守頂けない場合は、電波法の罰則が適用される可能性があることをご留意ください。日本テキサス・インスツルメンツ株式会社  
東京都新宿区西新宿 6 丁目 2 4 番 1 号  
西新宿三井ビル

3.3.3 *Notice for EVMs for Power Line Communication:* Please see [http://www.tij.co.jp/lstds/ti\\_ja/general/eStore/notice\\_02.page](http://www.tij.co.jp/lstds/ti_ja/general/eStore/notice_02.page)

電力線搬送波通信についての開発キットをお使いになる際の注意事項については、次のところをご覧ください。 <https://www.ti.com/ja-jp/legal/notice-for-evaluation-kits-for-power-line-communication.html>

#### 3.4 European Union

3.4.1 *For EVMs subject to EU Directive 2014/30/EU (Electromagnetic Compatibility Directive):*

This is a class A product intended for use in environments other than domestic environments that are connected to a low-voltage power-supply network that supplies buildings used for domestic purposes. In a domestic environment this product may cause radio interference in which case the user may be required to take adequate measures.

- 
- 4 *EVM Use Restrictions and Warnings:*
    - 4.1 EVMS ARE NOT FOR USE IN FUNCTIONAL SAFETY AND/OR SAFETY CRITICAL EVALUATIONS, INCLUDING BUT NOT LIMITED TO EVALUATIONS OF LIFE SUPPORT APPLICATIONS.
    - 4.2 User must read and apply the user guide and other available documentation provided by TI regarding the EVM prior to handling or using the EVM, including without limitation any warning or restriction notices. The notices contain important safety information related to, for example, temperatures and voltages.
    - 4.3 *Safety-Related Warnings and Restrictions:*
      - 4.3.1 User shall operate the EVM within TI's recommended specifications and environmental considerations stated in the user guide, other available documentation provided by TI, and any other applicable requirements and employ reasonable and customary safeguards. Exceeding the specified performance ratings and specifications (including but not limited to input and output voltage, current, power, and environmental ranges) for the EVM may cause personal injury or death, or property damage. If there are questions concerning performance ratings and specifications, User should contact a TI field representative prior to connecting interface electronics including input power and intended loads. Any loads applied outside of the specified output range may also result in unintended and/or inaccurate operation and/or possible permanent damage to the EVM and/or interface electronics. Please consult the EVM user guide prior to connecting any load to the EVM output. If there is uncertainty as to the load specification, please contact a TI field representative. During normal operation, even with the inputs and outputs kept within the specified allowable ranges, some circuit components may have elevated case temperatures. These components include but are not limited to linear regulators, switching transistors, pass transistors, current sense resistors, and heat sinks, which can be identified using the information in the associated documentation. When working with the EVM, please be aware that the EVM may become very warm.
      - 4.3.2 EVMs are intended solely for use by technically qualified, professional electronics experts who are familiar with the dangers and application risks associated with handling electrical mechanical components, systems, and subsystems. User assumes all responsibility and liability for proper and safe handling and use of the EVM by User or its employees, affiliates, contractors or designees. User assumes all responsibility and liability to ensure that any interfaces (electronic and/or mechanical) between the EVM and any human body are designed with suitable isolation and means to safely limit accessible leakage currents to minimize the risk of electrical shock hazard. User assumes all responsibility and liability for any improper or unsafe handling or use of the EVM by User or its employees, affiliates, contractors or designees.
    - 4.4 User assumes all responsibility and liability to determine whether the EVM is subject to any applicable international, federal, state, or local laws and regulations related to User's handling and use of the EVM and, if applicable, User assumes all responsibility and liability for compliance in all respects with such laws and regulations. User assumes all responsibility and liability for proper disposal and recycling of the EVM consistent with all applicable international, federal, state, and local requirements.
  5. *Accuracy of Information:* To the extent TI provides information on the availability and function of EVMs, TI attempts to be as accurate as possible. However, TI does not warrant the accuracy of EVM descriptions, EVM availability or other information on its websites as accurate, complete, reliable, current, or error-free.
  6. *Disclaimers:*
    - 6.1 EXCEPT AS SET FORTH ABOVE, EVMS AND ANY MATERIALS PROVIDED WITH THE EVM (INCLUDING, BUT NOT LIMITED TO, REFERENCE DESIGNS AND THE DESIGN OF THE EVM ITSELF) ARE PROVIDED "AS IS" AND "WITH ALL FAULTS." TI DISCLAIMS ALL OTHER WARRANTIES, EXPRESS OR IMPLIED, REGARDING SUCH ITEMS, INCLUDING BUT NOT LIMITED TO ANY EPIDEMIC FAILURE WARRANTY OR IMPLIED WARRANTIES OF MERCHANTABILITY OR FITNESS FOR A PARTICULAR PURPOSE OR NON-INFRINGEMENT OF ANY THIRD PARTY PATENTS, COPYRIGHTS, TRADE SECRETS OR OTHER INTELLECTUAL PROPERTY RIGHTS.
    - 6.2 EXCEPT FOR THE LIMITED RIGHT TO USE THE EVM SET FORTH HEREIN, NOTHING IN THESE TERMS SHALL BE CONSTRUED AS GRANTING OR CONFERRING ANY RIGHTS BY LICENSE, PATENT, OR ANY OTHER INDUSTRIAL OR INTELLECTUAL PROPERTY RIGHT OF TI, ITS SUPPLIERS/LICENSORS OR ANY OTHER THIRD PARTY, TO USE THE EVM IN ANY FINISHED END-USER OR READY-TO-USE FINAL PRODUCT, OR FOR ANY INVENTION, DISCOVERY OR IMPROVEMENT, REGARDLESS OF WHEN MADE, CONCEIVED OR ACQUIRED.
  7. *USER'S INDEMNITY OBLIGATIONS AND REPRESENTATIONS.* USER WILL DEFEND, INDEMNIFY AND HOLD TI, ITS LICENSORS AND THEIR REPRESENTATIVES HARMLESS FROM AND AGAINST ANY AND ALL CLAIMS, DAMAGES, LOSSES, EXPENSES, COSTS AND LIABILITIES (COLLECTIVELY, "CLAIMS") ARISING OUT OF OR IN CONNECTION WITH ANY HANDLING OR USE OF THE EVM THAT IS NOT IN ACCORDANCE WITH THESE TERMS. THIS OBLIGATION SHALL APPLY WHETHER CLAIMS ARISE UNDER STATUTE, REGULATION, OR THE LAW OF TORT, CONTRACT OR ANY OTHER LEGAL THEORY, AND EVEN IF THE EVM FAILS TO PERFORM AS DESCRIBED OR EXPECTED.

8. *Limitations on Damages and Liability:*

8.1 *General Limitations.* IN NO EVENT SHALL TI BE LIABLE FOR ANY SPECIAL, COLLATERAL, INDIRECT, PUNITIVE, INCIDENTAL, CONSEQUENTIAL, OR EXEMPLARY DAMAGES IN CONNECTION WITH OR ARISING OUT OF THESE TERMS OR THE USE OF THE EVMS , REGARDLESS OF WHETHER TI HAS BEEN ADVISED OF THE POSSIBILITY OF SUCH DAMAGES. EXCLUDED DAMAGES INCLUDE, BUT ARE NOT LIMITED TO, COST OF REMOVAL OR REINSTALLATION, ANCILLARY COSTS TO THE PROCUREMENT OF SUBSTITUTE GOODS OR SERVICES, RETESTING, OUTSIDE COMPUTER TIME, LABOR COSTS, LOSS OF GOODWILL, LOSS OF PROFITS, LOSS OF SAVINGS, LOSS OF USE, LOSS OF DATA, OR BUSINESS INTERRUPTION. NO CLAIM, SUIT OR ACTION SHALL BE BROUGHT AGAINST TI MORE THAN TWELVE (12) MONTHS AFTER THE EVENT THAT GAVE RISE TO THE CAUSE OF ACTION HAS OCCURRED.

8.2 *Specific Limitations.* IN NO EVENT SHALL TI'S AGGREGATE LIABILITY FROM ANY USE OF AN EVM PROVIDED HEREUNDER, INCLUDING FROM ANY WARRANTY, INDEMNITY OR OTHER OBLIGATION ARISING OUT OF OR IN CONNECTION WITH THESE TERMS, , EXCEED THE TOTAL AMOUNT PAID TO TI BY USER FOR THE PARTICULAR EVM(S) AT ISSUE DURING THE PRIOR TWELVE (12) MONTHS WITH RESPECT TO WHICH LOSSES OR DAMAGES ARE CLAIMED. THE EXISTENCE OF MORE THAN ONE CLAIM SHALL NOT ENLARGE OR EXTEND THIS LIMIT.

9. *Return Policy.* Except as otherwise provided, TI does not offer any refunds, returns, or exchanges. Furthermore, no return of EVM(s) will be accepted if the package has been opened and no return of the EVM(s) will be accepted if they are damaged or otherwise not in a resalable condition. If User feels it has been incorrectly charged for the EVM(s) it ordered or that delivery violates the applicable order, User should contact TI. All refunds will be made in full within thirty (30) working days from the return of the components(s), excluding any postage or packaging costs.

10. *Governing Law:* These terms and conditions shall be governed by and interpreted in accordance with the laws of the State of Texas, without reference to conflict-of-laws principles. User agrees that non-exclusive jurisdiction for any dispute arising out of or relating to these terms and conditions lies within courts located in the State of Texas and consents to venue in Dallas County, Texas. Notwithstanding the foregoing, any judgment may be enforced in any United States or foreign court, and TI may seek injunctive relief in any United States or foreign court.

Mailing Address: Texas Instruments, Post Office Box 655303, Dallas, Texas 75265  
Copyright © 2023, Texas Instruments Incorporated

## IMPORTANT NOTICE AND DISCLAIMER

TI PROVIDES TECHNICAL AND RELIABILITY DATA (INCLUDING DATA SHEETS), DESIGN RESOURCES (INCLUDING REFERENCE DESIGNS), APPLICATION OR OTHER DESIGN ADVICE, WEB TOOLS, SAFETY INFORMATION, AND OTHER RESOURCES "AS IS" AND WITH ALL FAULTS, AND DISCLAIMS ALL WARRANTIES, EXPRESS AND IMPLIED, INCLUDING WITHOUT LIMITATION ANY IMPLIED WARRANTIES OF MERCHANTABILITY, FITNESS FOR A PARTICULAR PURPOSE OR NON-INFRINGEMENT OF THIRD PARTY INTELLECTUAL PROPERTY RIGHTS.

These resources are intended for skilled developers designing with TI products. You are solely responsible for (1) selecting the appropriate TI products for your application, (2) designing, validating and testing your application, and (3) ensuring your application meets applicable standards, and any other safety, security, regulatory or other requirements.

These resources are subject to change without notice. TI grants you permission to use these resources only for development of an application that uses the TI products described in the resource. Other reproduction and display of these resources is prohibited. No license is granted to any other TI intellectual property right or to any third party intellectual property right. TI disclaims responsibility for, and you will fully indemnify TI and its representatives against, any claims, damages, costs, losses, and liabilities arising out of your use of these resources.

TI's products are provided subject to [TI's Terms of Sale](#) or other applicable terms available either on [ti.com](https://www.ti.com) or provided in conjunction with such TI products. TI's provision of these resources does not expand or otherwise alter TI's applicable warranties or warranty disclaimers for TI products.

TI objects to and rejects any additional or different terms you may have proposed.

Mailing Address: Texas Instruments, Post Office Box 655303, Dallas, Texas 75265  
Copyright © 2023, Texas Instruments Incorporated