

- NOTES:
- PRECEDING ENG. NO. IN CHART DESIGNATES STANDARD PRODUCT.
 - SOLDERABILITY: WHEN PARTS ARE SOLDERED AT A TEMPERATURE OF 230°C (446°F) FOR 5 SECONDS, EACH SOLDERED SURFACE SHALL BE A MINIMUM OF 95% COVERED WITH A SMOOTH CONTINUOUS ADHERENT COATING. FOR OTHER INFORMATION SEE ES-152.
 - PIN PUSH OUT FORCE: PRIOR TO SOLDERING, A 3 POUND MINIMUM FORCE (IN EITHER DIRECTION) SHALL BE REQUIRED TO PUSH THE PIN OUT OF THE HEADER.
 - FOR ADDITIONAL INFORMATION AND TESTING PROCEDURES SEE PS-08-50.
 - PARTS ARE STACKABLE END TO END ON (3.96)/.156 CENTERS.
 - FOR PART WITH PEGS SEE DWG NO. SDA-42492
 - BURRS DUE TO CUTTING OFF OF PINS MUST NOT VARY FROM CENTERLINE OF PIN AT DATUM -D- BY MORE THAN .008 IN ANY DIRECTION.

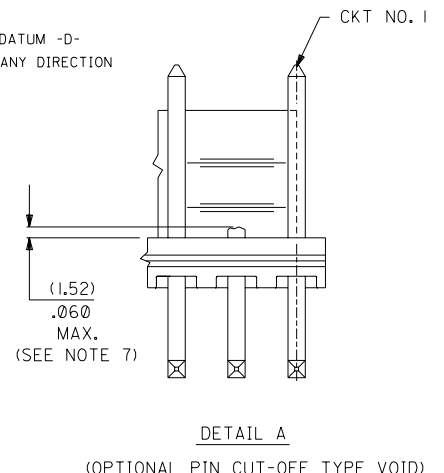

NO. OF CKT'S.	DIM. A	DIM. B
2	(3.96±.05) .156±.002	(7.77) .306
3	(7.92±.08) .312±.003	(11.73) .462
4	(11.89±.08) .468±.003	(15.70) .618
5	(15.85±.10) .624±.004	(19.66) .774
6	(19.81±.10) .780±.004	(23.62) .930
7	(23.77±.10) .936±.004	(27.58) 1.086
8	(27.74±.13) 1.092±.005	(31.55) 1.242
9	(31.70±.13) 1.248±.005	(35.51) 1.398
10	(35.66±.13) 1.404±.005	(39.47) 1.554
11	(39.62±.15) 1.560±.006	(43.43) 1.710
12	(43.59±.15) 1.716±.006	(47.40) 1.866
13	(47.55±.15) 1.872±.006	(51.36) 2.022
14	(51.51±.18) 2.028±.007	(55.32) 2.178
15	(55.47±.18) 2.184±.007	(59.28) 2.334
16	(59.44±.18) 2.340±.007	(63.25) 2.490
17	(63.40±.20) 2.496±.008	(67.21) 2.646
18	(67.36±.20) 2.652±.008	(71.17) 2.802

MATERIAL: HEADER: GLASS FILLED POLYESTER, 94V-0, MOLDED NATURAL (WHITE).
PIN: BRASS

PLATINGS:
(102) ELECTRO TIN .000450/.000200 OVER .000200/.000100 COPPER
(567) SELECT GOLD 15 M.I. MIN, SELECT TIN/LEAD 100 M.I. MIN., OVER NICKEL
(569) SELECT GOLD 30 M.I. MIN, SELECT TIN/LEAD 100 M.I. MIN., OVER NICKEL
FOR ADDITIONAL INFORMATION SE SDES-88.

DIMENSIONS SHOWN (METRIC) INCH UNLESS OTHERWISE SPECIFIED TOLERANCES: ANGULAR ± 1/2°		□ = 0 ▽ = 0 REVISE ONLY ON CAD SYSTEM	
3 PLACE ±	INCH	METRIC	
2 PLACE ±			
1 PLACE ±			
DRAFT WHERE APPLICABLE MUST REMAIN WITHIN DIMENSIONS		MOLEX INCORPORATED SHEET NO. DATE LISLE, ILL. 60532 U.S.A. 1 OF 6 09/09/87	
DRWG. BY: SAMIEC CHK'D. BY: PATEL		SEE CHART SDA-41792	
APP'D. BY: LENZ SCALE:		FILE NAME: S41792X1 DIV. SIZE MOLEX INC. AND SHOULD NOT BE USED WITHOUT WRITTEN PERMISSION. KK C	
LTR.	REVISIONS	LTR.	REVISIONS

6	E
5	E2
4	E1
3	E
2	E
1	E2

