

ITEM	Q'TY	PART NUMBER	PART DESCRIPTION
1	1	PM3-PL	3mm Polycarbonate Panel Mount Housing
2	1	PM3-FP22	2.2mm to 3mm Flexible Light Pipe Adapter
3	1	PM3-VS	3mm Sealing Ring
4	1	WASH-1009	M6 Internal Tooth Lock Washer
5	1	NUT-1004	M6x1 Thin Nut
6	1	FLPS1522-X.XXX	1.5mm x 2.2mm Flexible Light Pipe

REV.	DESCRIPTION	DATE	APPROVED
B	Engineering Release	06/19/12	T. Y.
C	Updated Descriptions	03/21/13	T. Y.
D	Corrected Length Call Out & Updated Title	08/23/16	J. C.

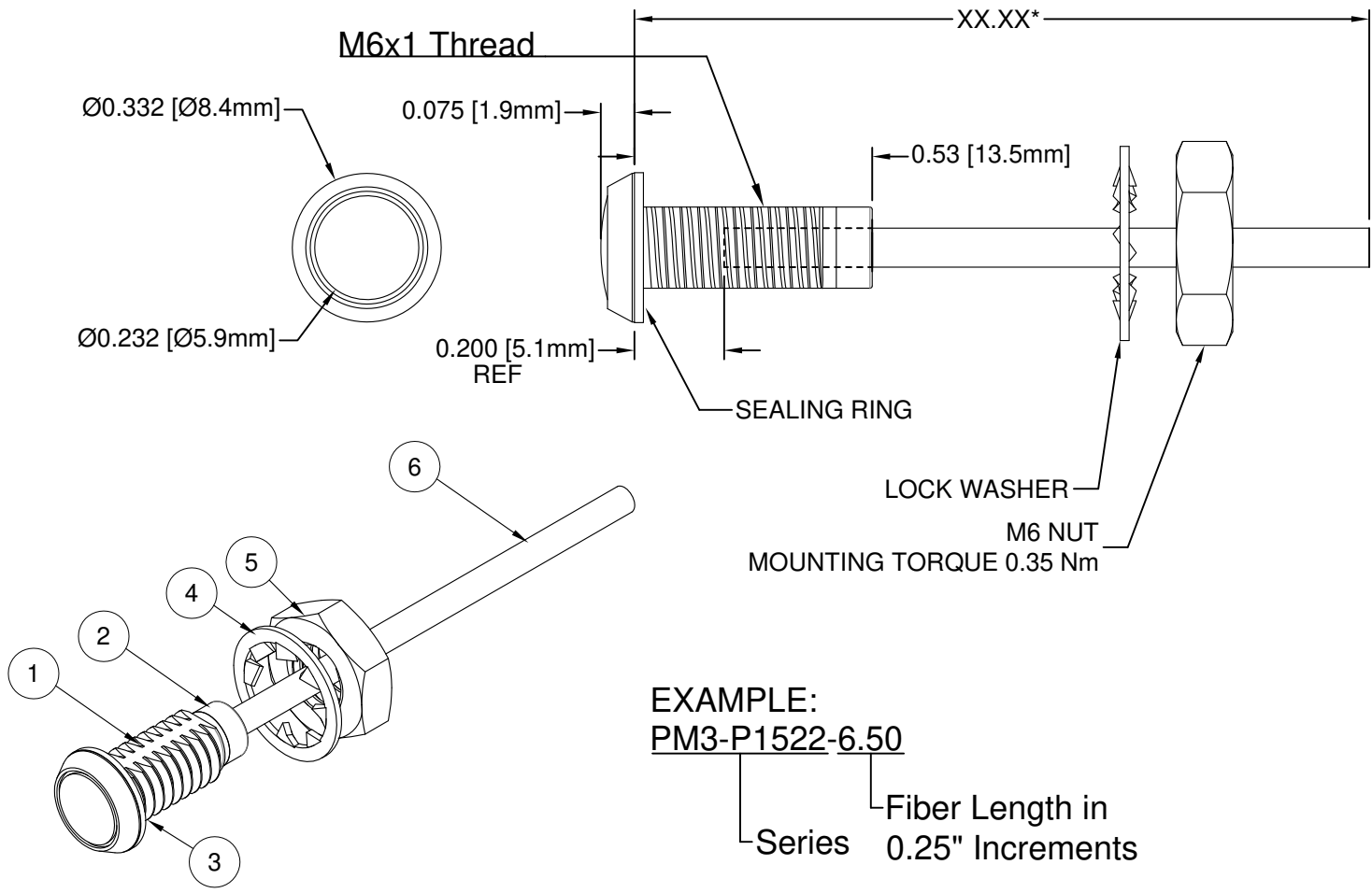

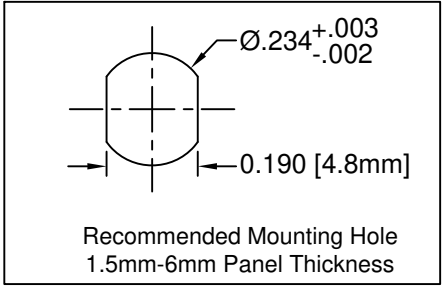

*Length "XX.XX"	Tolerance
1.00" ~ 16.00"	±0.05"
16.25" ~ 40.00"	±0.15"
40.25" ~ 80.00"	±0.30"
80.25" ~ 500.0"	±0.5%

EXAMPLE:
PM3-P1522-6.50
 Series Fiber Length in 0.25" Increments



- NOTES:
1. SEALED TO IP67 RATING
 2. ROHS COMPLIANT
 3. MOUNTING HARDWARE SHIPPED NON-ASSEMBLED
 4. INSERT SEALING RING ON PANEL MOUNT PRIOR TO PANEL INSERTION

STANDARD TOLERANCE (UNLESS OTHERWISE SPECIFIED)		 4 THOMAS, IRVINE, CA. 92618 TEL: (949) 951-8808 FAX: (949) 951-3974	
DECIMALS	ANGULAR		
.X ±.1	X° ± 1°		
.XX ±.02		 TITLE: IP67 Rated Panel Mount Flexible Light Pipe Indicator	
.XXX ±.010			
DESIGNED: B. Oliver	DATE: 04/12/12	PART NO: PM3-P1522-XX.XX	REVISION: D
CHECKED: T. Yin	DATE: 04/12/12	CAGE CODE : 32559	SHEET # 1 OF 1
CAD GENERATED DOCUMENT. DO NOT MEASURE DRAWING.			