

ATLANTIC VERSION TERMINATOR INTERFACE ADAPTER	PART NUMBER	REVISION	DESCRIPTION	FEED TYPE	CONVERT TO	PART NUMBERS REQUIRED					
	2150546-1	A	FINE CRIMP HEIGHT ADJUST	MECHANICAL	PNEUMATIC FEED	2119950-1	2119792-2	-	2119641-1	-	2063440-1
					SERVO LATCH PLATE	2119951-1	1901697-1	8-2150546-5	-	-	2168400-7 (QUANTITY 2)
					SMART APPLICATOR	2161326-1	-	8-2150546-4	-	-	-
	2150546-2	A	FINE CRIMP HEIGHT ADJUST	PNEUMATIC	MECHANICAL FEED	2119949-1	2063961-1	5-18022-5	2119653-1	-	-
					SERVO LATCH PLATE	2119951-1	1901697-1	8-2150546-5	-	-	2168400-7 (QUANTITY 2)
					SMART APPLICATOR	2161326-1	-	8-2150546-4	-	-	-
	2150546-5	A	FINE CRIMP HEIGHT ADJUST	SERVO LATCH PLATE	MECHANICAL FEED	2119949-1	2063961-1	5-18022-5	2119653-1	-	-
				PNEUMATIC FEED	2119950-1	2119792-2	-	2119641-1	-	2063440-1	
2150546-6	A	NON-CRIMP HEIGHT ADJUST	SERVO LATCH PLATE	-	-	-	-	-	-	-	
2150546-7	A	FINE CRIMP HEIGHT ADJUST	NONE	-	-	-	-	-	-	-	
7-2150546-7	A	CRIMP TOOLING KIT	-	-	-	-	-	-	-	-	

APPLICATOR DATA		
CRIMP	SIZE	TYPE
WIRE	1.57 mm [.062]	F
INSUL	1.78 mm [.070]	O
APPL INSTRUCTIONS 408-10390		

TERMINAL DATA: TE TERMINAL		TE CRIMP SPECIFICATION
TERMINAL NAME: FASTON RECEPTACLE .110 SERIES		
WIRE STRIP LENGTH		INSULATION DIAMETER RANGE
5.21-5.97 mm [.205-.235 IN]		Ø1.02-1.52 mm [.040-.060 IN]
TERMINAL APPLICATION SPECIFICATION	114-2036	
TERMINALS APPLIED		
TE TERMINAL	TE TERMINAL	TE TERMINAL
140716-2		

WIRE SIZE	CRIMP HEIGHT mm [INCH]	CRIMP HEIGHT REFERENCE SETTING
22 AWG OR 0.30mm2	0.81+/-0.05 [.032+/-0.002]	8.1
24 AWG OR 0.20mm2	0.76+/-0.05 [.030+/-0.002]	8.6

- 1 RECOMMENDED SPARE PARTS
- 2 GREASE BEARING SURFACES LIGHTLY
- 3 LUBRICATE DAILY PER THE APPLICATOR INSTRUCTION SHEET SUPPLIED WITH THE APPLICATOR.
- 4 APPLICATOR SPECIFIC DATA TO BE ENTERED INTO BLANK MEMORY CHIP AT ASSEMBLY. SEE BELOW FOR PART NUMBER:  
 MECHANICAL FEED WITH "SMART APPLICATOR" CONVERSION: 8-2150546-4  
 PNEUMATIC FEED WITH "SMART APPLICATOR" CONVERSION: 8-2150546-4  
 SERVO FEED WITH "FINE CRIMP HEIGHT ADJUST": 8-2150546-5  
 SERVO FEED WITH "NON-CRIMP HEIGHT ADJUST": 8-2150546-6
- 5. ADJUSTMENT OF THE STRIPPER MAY BE REQUIRED WHEN MOVING THE APPLICATOR BETWEEN BENCH AND LEADMAKER APPLICATIONS.
- 6 APPLY PART NUMBER 1-23419-5 LOCTITE TO THREADS OF ITEMS 62 & 180. APPLY PART NUMBER 2-23419-6 LOCTITE TO THREADS OF ITEM 242. FOR -6 ONLY APPLY PART NUMBER 1-23419-5 LOCTITE TO THREADS OF ITEMS 37 & 180.
- 7 GREASE THREADS, GROOVE AND O-RING ON ITEMS 35 & 252.
- 8 MAGNET, ITEM 166 MUST BE ORIENTED CORRECTLY IN ORDER TO PROPERLY ACTUATE THE COUNTER.
- 9 CRIMP HEIGHT REFERENCE SETTING WAS THE SETTING USED WHEN THE APPLICATOR WAS QUALIFIED AT THE FACTORY. ADJUSTMENT MAY BE NECESSARY WHEN RUNNING APPLICATOR IN THE FIELD.
- 10 SPARE FEED CAM STORAGE LOCATION REFER TO INSTRUCTION SHEET FOR ADDITIONAL INFORMATION.
- 11 THE RECOMMENDED SET-UP FOR END FEED APPLICATORS IS POST-FEED WITH ITEM 2119653-1. THE APPLICATOR CAN BE CONFIGURED FOR PRE-FEED WITH ITEM 2119652-1 BUT MAY ENCOUNTER PROBLEMS WITH SOME APPLICATIONS. FEED ISSUES OR TERMINAL JAMMING MAY OCCUR IN THE PRE-FEED CONFIGURATION.
- 12 WHEN ASSEMBLING -6 NON-CRIMP HEIGHT ADJUST APPLICATOR USE SHIM PACK 2119957-2 TO ALIGN APPLICATOR'S MAXIMUM WIRE CRIMP HEIGHT AT NORMAL TERMINATOR SHUT HEIGHT

**\*WARNING**  
 ON INSTALLATION, SET WIRE DISC, ITEM 40 TO LARGEST WIRE SIZE SETTING. USE OF SETTINGS BELOW MINIMUM REQUIRED CRIMP HEIGHT SETTING WILL CAUSE DAMAGE TO CRIMP TOOLING.

-77	-7	-6	-5	-2	-1	PART NO	DESCRIPTION	ITEM NO
-	-	1	-	-	-	2119957-2	APPLICATOR SHIM PACK	260
-	1	-	1	1	1	8-21084-0	O-RING, .676 ID, .070 DIA. MAT.	252
-	-	-	-	1	-	2119640-1	PUSH ROD, AIR FEED	250
-	-	-	-	1	-	2079988-1	BUSHING, LCH5-12, MISUMI	249
-	-	-	-	1	-	2119641-1	FEED CAM, AIR FEED	248
-	1	-	1	1	1	2119798-1	DETENT PIN	247
-	1	-	1	1	1	1-22279-3	SPRING, COMPRESSION	246
-	-	1	-	-	-	2119759-1	RAM, AMP STYLE, END FEED, NON-ADJUST	245

**ATLANTIC VERSION**  
 Shown on sheets 1 of 4 & 2 of 4  
 (Pacific version shown on sheets 3 of 4 & 4 of 4)

SET UP GAUGE	LOC	DIST	REVISIONS			
2119599-2	A	66	REV	DATE	BY	APPV
			1	DEVELOPMENT	16APR2015	JH UG
			A	RELEASED	21MAY2015	JH TE

-	1	1	1	1	1	2119082-4	CAM, SNAIL, INSULATION ADJUSTMENT	244	
-	1	1	1	1	1	2079764-1	WASHER, WAVE SPRING, CREST-TO-CREST	243	
-	1	1	1	1	1	2119083-1	RETAINER, INSULATION DIAL	242	
-	-	2	2	-	-	2168400-7	SHCS, LOW HEAD, RoHS, M5 X 10	240	
-	-	-	-	-	1	2119580-1	MECHANICAL FEED ASSEMBLY	239	
-	-	-	-	-	1	2063440-1	AIR FEED MODULE	238	
-	-	1	1	-	-	2119740-2	TAG, IDENTIFICATION	213	
-	-	REFREF	-	-	-	1901697-1	FEED FINGER ASSEMBLY, EF	183	
-	1	1	1	1	1	1-1752354-0	STANDOFF, HOLD-DOWN	180	
-	1	1	1	1	1	6-993111-6	PIN, SLOTTED SPRING 3.0 X 14.0	177	
-	1	1	1	1	1	8-22280-7	SPRING, COMPRESSION	176	
-	1	1	1	1	1	1752353-2	GUIDE PIN, HOLDDOWN	175	
-	1	1	1	1	1	1901680-2	GUIDE PIN, HOLDDOWN	174	
-	-	-	-	2	-	21045-3	RING, RETAIN, EXTERN, 3/16 CRESCENT	172	
-	1	1	1	1	1	994969-1	MAGNET, RARE EARTH HIGH ENERGY	166	
-	REFREF	REFREF	REFREF	REFREF	REFREF	994970-2	COUNTER, MAGNETIC	164	
-	-	-	-	-	1	240638-1	SPRING, FEED FINGER	163	
-	-	-	-	-	1	3-23627-7	PIN, RETAIN, GRVD, 3/16 X .854	137	
-	-	REFREF	-	-	-	SEE NOTE 4	MEMORY CHIP, PROGRAMMED	135	
-	-	1	1	-	-	1633743-1	SERVO FEED LATCH ASM	133	
-	1	1	1	1	1	455888-5	SPACER, CRIMPER	82	
-	1	1	1	1	1	2119956-2	DOCUMENTATION PACKAGE	71	
-	2	2	2	2	2	2-18032-2	SCR, SET, FLT POINT M3 X 10.0	70	
-	1	-	-	1	1	2119740-1	TAG, IDENTIFICATION	67	
-	2	2	2	2	2	2168078-1	SCREW, DRIVE, RH, RoHS, 2 x .188	66	
-	1	1	1	1	1	1901681-5	HOLDDOWN, TERMINAL	65	
-	2	2	2	2	2	2168400-8	SHCS, LOW HEAD, RoHS, M4 X 16	64	
-	1	-	1	1	1	2119793-1	LIMITER, ADJUSTMENT BOLT	63	
-	3	-	3	3	3	992763-5	SCR, SET, SOC, CONE POINT, M3 X 4.0	62	
-	1	1	1	1	1	2079383-4	SCR, BHSC, RoHS (M4 X 8)	60	
-	-	-	-	-	1	5-18022-5	SCR, HEX HD CAP, M4 X 6.0	59	
-	-	-	-	-	1	2063961-1	FEED FINGER	58	
-	3	3	3	3	3	2168400-4	SHCS, LOW HEAD, RoHS, M4 X 8	57	
-	2	2	2	2	2	2168083-2	SCR, SKT HD CAP, RoHS, M4 X 8.0	56	
-	2	2	2	2	2	5018030-2	NUT, HEX, REG, RoHS, M4	55	
-	2	2	2	2	2	5018030-1	NUT, HEX, REG, RoHS, M3	54	
-	2	2	2	2	2	986965-8	NUT, LOCK, HEX, TORQUE (M4)	53	
-	1	1	1	1	1	1-5018030-0	NUT, HEX, REG, RoHS, M3.5	52	
-	-	-	-	-	1	2119792-2	PAWL, EF, AIR	51	
-	-	-	-	-	1	2	18023-9	SCR, SKT HD CAP M4 X 6.0	49
-	-	-	-	-	1	2119652-1	FEED CAM, PRE FEED	48	
-	-	-	-	-	1	2119653-1	FEED CAM, POST FEED	47	
-	1	1	1	1	1	2119655-5	APPLICATOR BASIC ASSEMBLY, EF	46	
-	1	-	1	1	1	2119369-1	RAM, AMP STYLE, END FEED	44	
-	1	1	1	1	1	2079383-7	SCR, BHSC, RoHS (M8 X 25)	41	
-	1	-	1	1	1	2119645-1	DISC, NUMBERED FA WIRE ADJUSTMENT	40	
-	1	-	1	1	1	2119957-1	APPLICATOR SHIM PACK	39	
-	1	1	1	1	1	1-2119644-4	RAM WASHER, PRECISION	38	
-	1	1	1	1	1	2119085-1	FA HEAD, ATLANTIC STYLE	37	
-	1	-	1	1	1	2119092-1	BOLT, ADJUSTMENT	35	
-	7	7	7	7	7	1-18028-2	WASHER, FLAT, REG M4	33	
-	2	2	2	2	2	2168083-9	SCR, SKT HD CAP, RoHS, M4 X 20	31	
-	2	2	2	2	2	1-2168083-0	SCR, SKT HD CAP, RoHS, M4 X 10	29	
-	1	1	1	1	1	240639-1	STRIPPER (MACHINING)	27	
-	2	2	2	2	2	1320906-1	STUD, THREADED	25	
-	1	1	1	1	1	1752371-5	PLATE, STRIP GUIDE	24	
-	1	1	1	1	1	1-240825-1	PLATE, STRIP HOLD DOWN	23	
-	2	2	2	2	2	2-22281-3	SPRING, COMPRESSION	22	
-	1	1	1	1	1	1752373-4	DRAG	20	
-	2	2	2	2	2	1901259-2	GUIDE, LOWER STRIP	18	
-	4	4	4	4	4	1-2079383-1	SCR, BHSC, RoHS (M6 X 12)	17	
-	1	1	1	1	1	1752360-1	SPACER, HOLD-DOWN	13	
-	1	1	1	1	1	240644-1	PLATE, REAR SHEAR	11	
-	-	-	-	-	-	-	-	10	
-	1	1	1	1	1	690482-6	PLATE, FRONT SHEAR	9	
-	1	1	1	1	1	1333214-5	ANVIL, EF .062	8	
-	1	1	1	1	1	2217206-4	BLADE, SLUG	7	
-	-	-	-	-	-	-	-	6	
-	1	1	1	1	1	3-240641-0	SPACER	5	
-	1	1	1	1	1	238009-1	BLOCK, FL CRIMPER SPACER	4	
-	1	1	1	1	1	6-1803018-8	CRIMPER, INSULATION O	3	
-	1	1	1	1	1	455888-7	SPACER, CRIMPER	2	
-	1	1	1	1	1	1-456403-5	CRIMPER, WIRE PREMIUM	1	

DIMENSIONS:		TOLERANCES UNLESS OTHERWISE SPECIFIED:		DATE		NAME	
mm	0 PLC ±.5	1 PLC ±.5	2 PLC ±.13	3 PLC ±.013	4 PLC ±.0001	ANGLES ±.0001	FINISH
MATERIAL		FINISH		WEIGHT		SCALE	
Customer Accessible Production Drawing		SCALE 1:1		SHEET 1 OF 4		REV A	

REVISONS		DATE	OWN	APVD
A	66	SEE SHEET 1	-	-

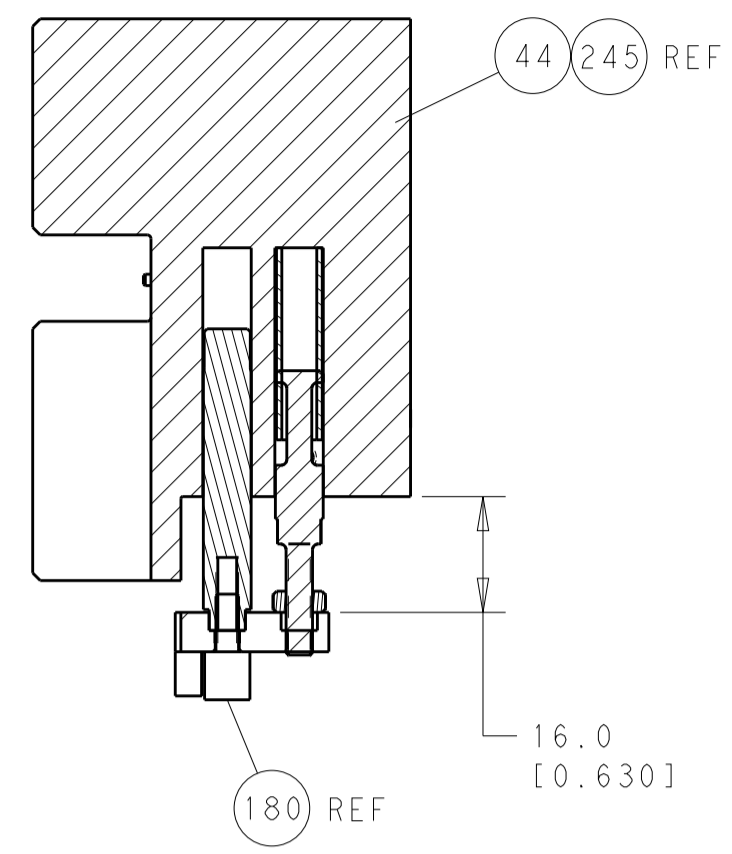

HOLDDOWN SET-UP

FEED TYPE  
MECHANICAL

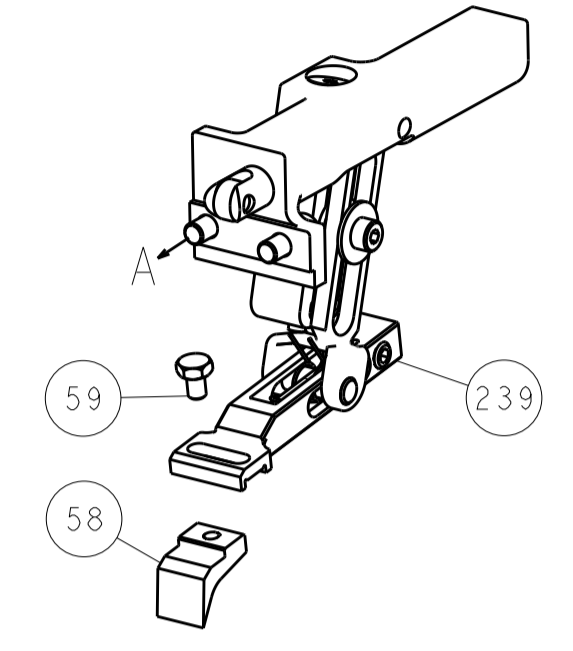

PNEUMATIC

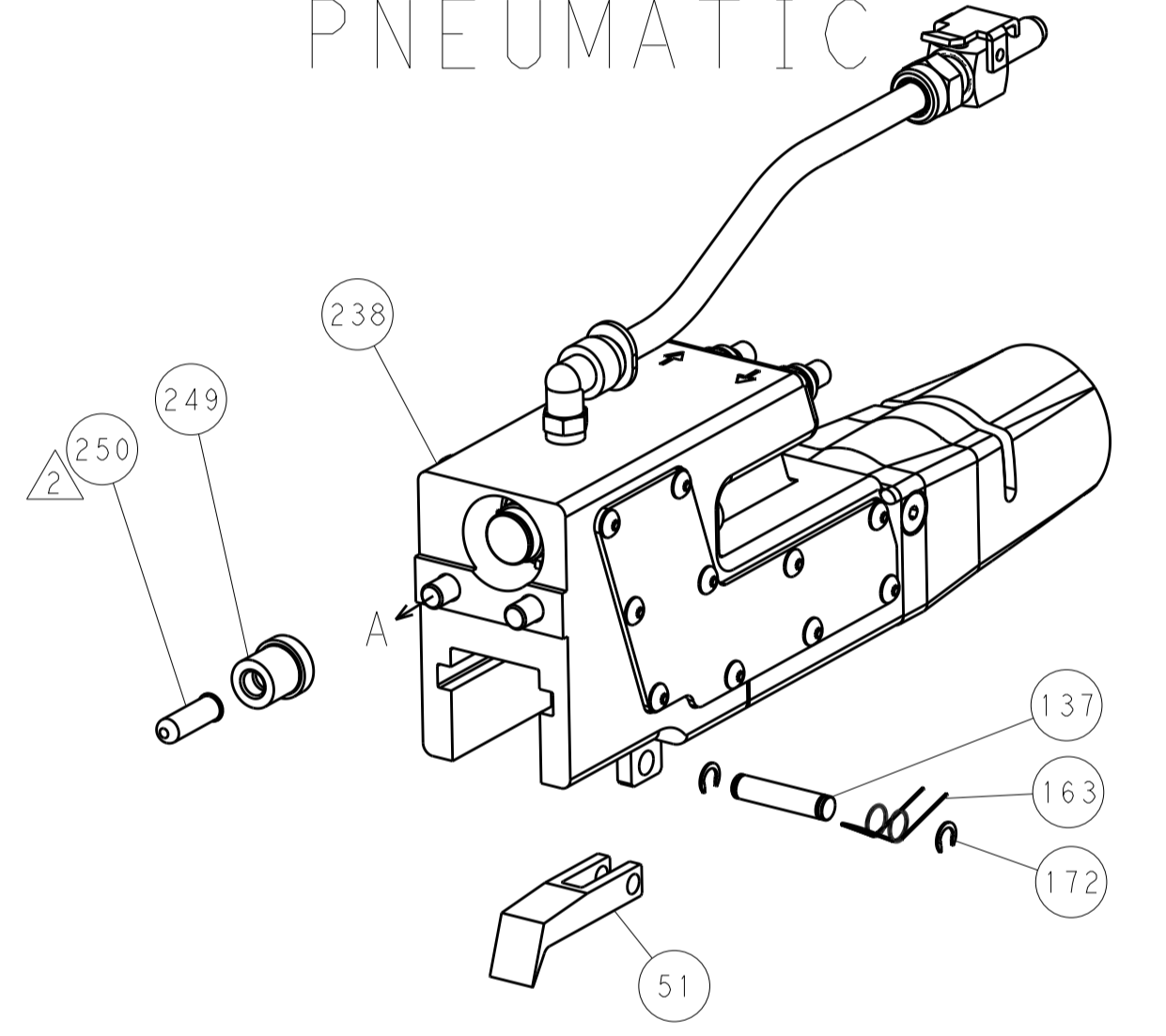

SERVO  
LATCH PLATE

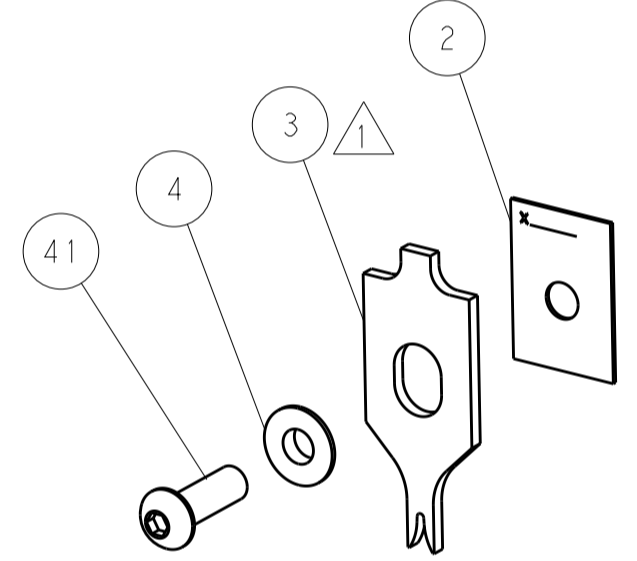
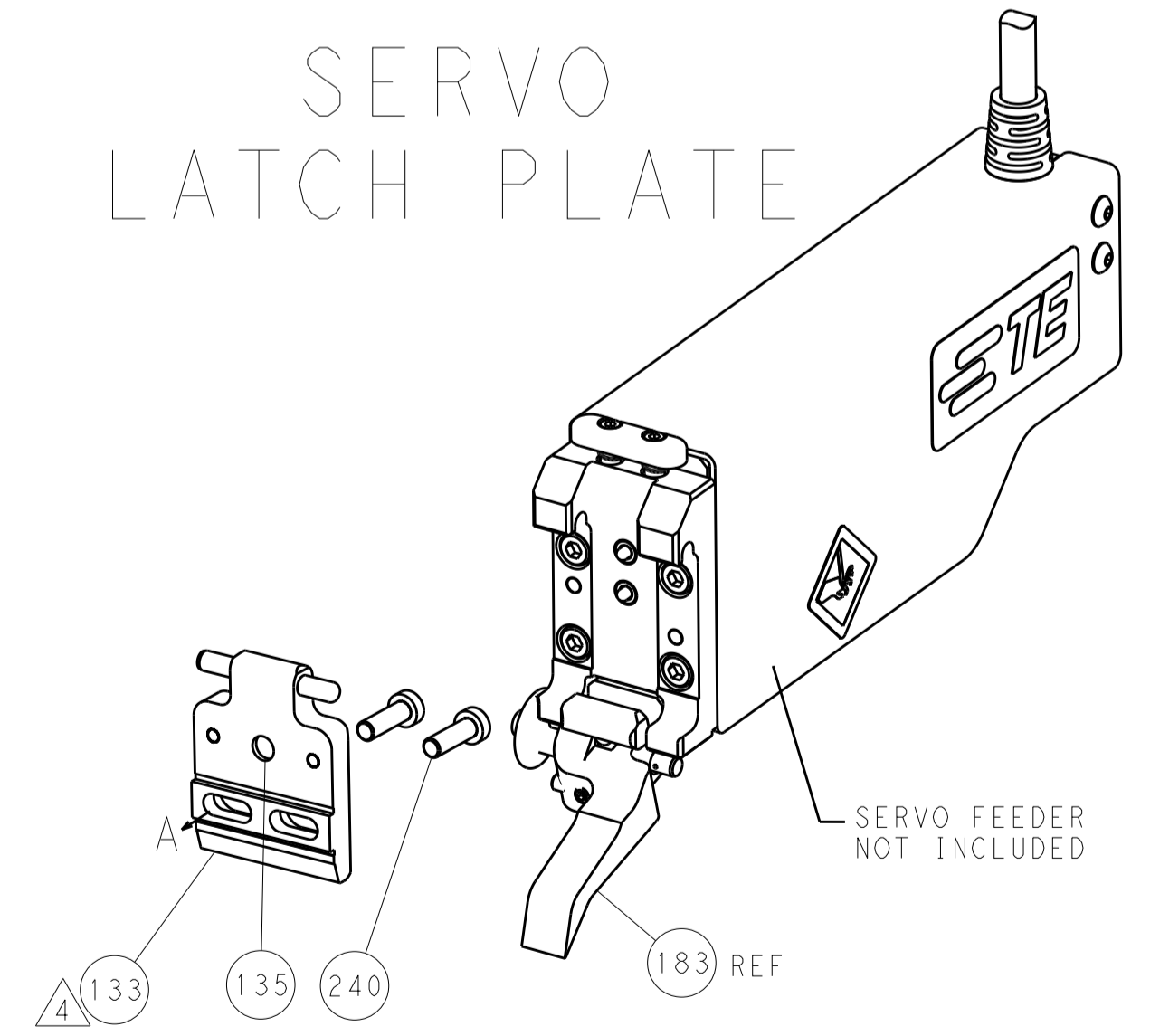

CAM POSITIONS

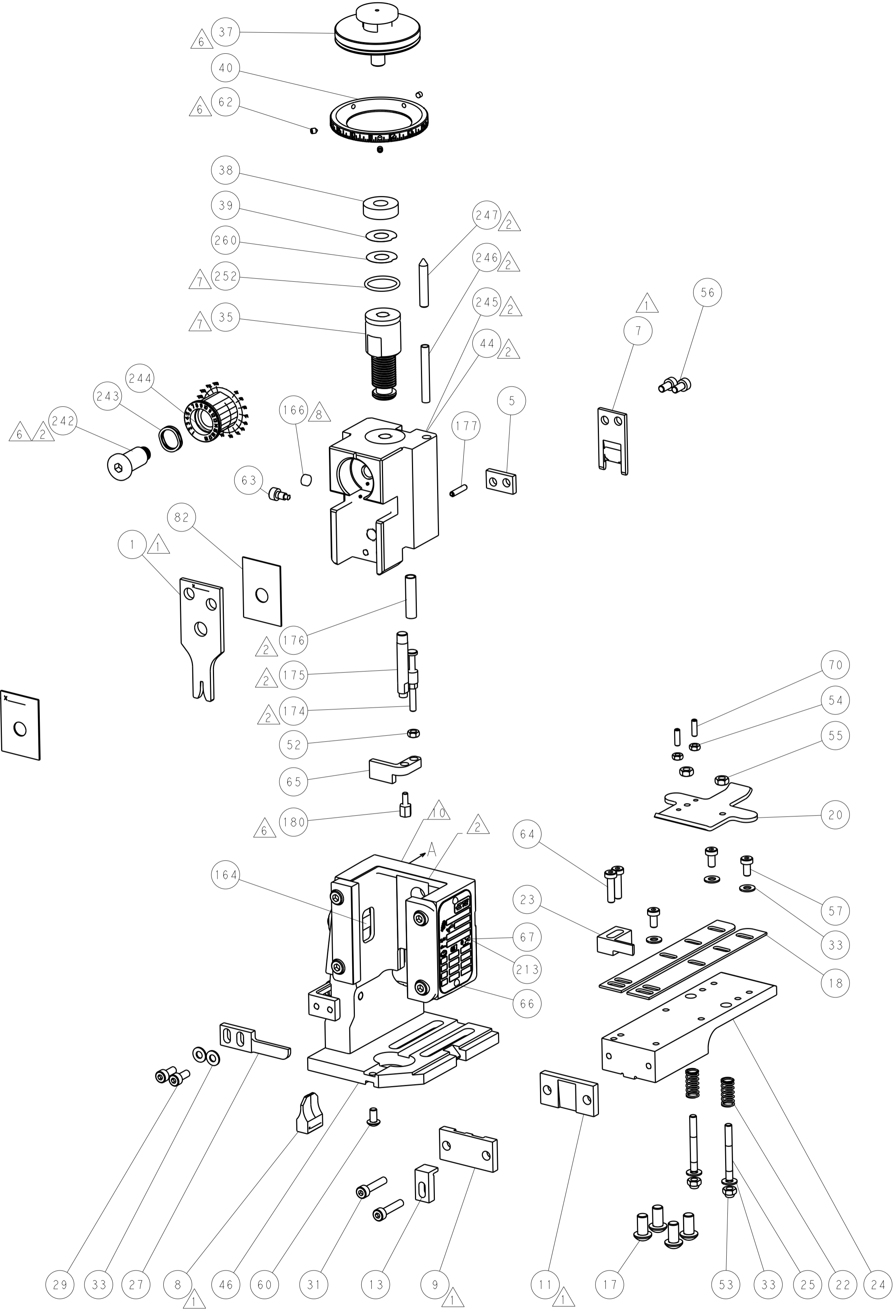
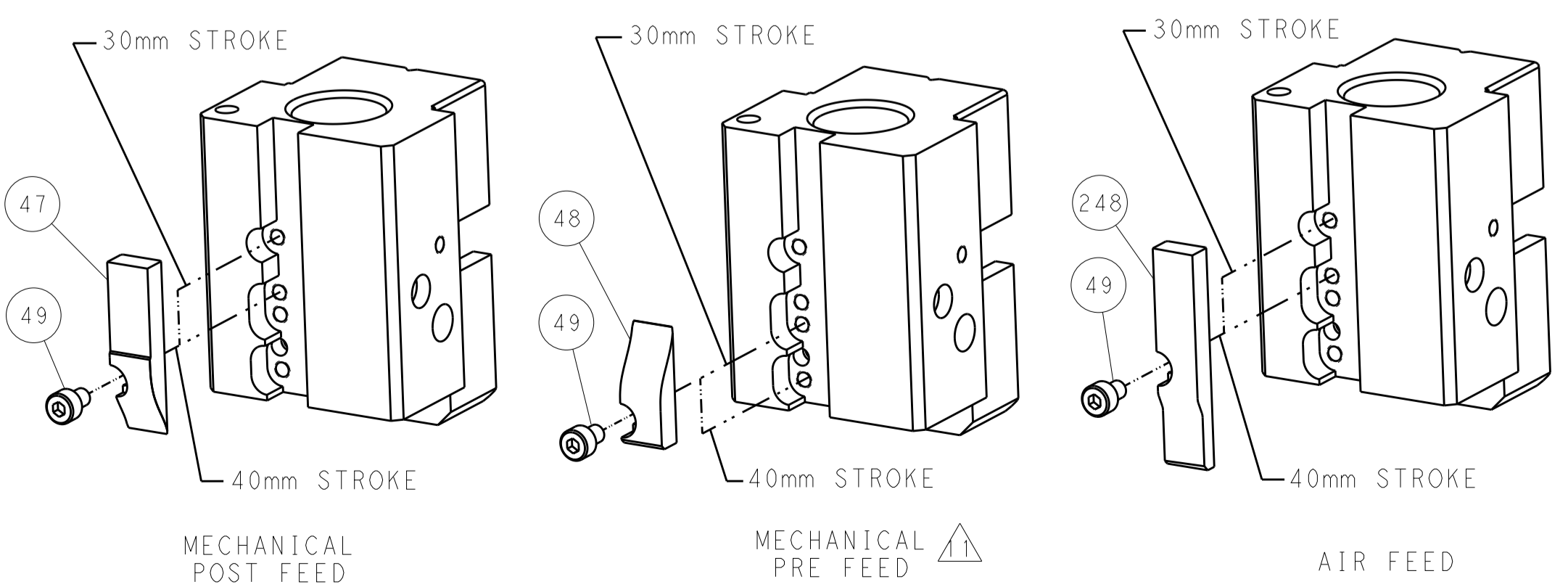

ATLANTIC VERSION  
Shown on sheets 1 of 4 & 2 of 4  
(Pacific version shown on sheets 3 of 4 & 4 of 4)

DIMENSIONS:		TOLERANCES UNLESS OTHERWISE SPECIFIED:		DWG: J. HOU 16APR2015		TE Connectivity	
mm		0 PLC ±.5		CHK: L. ZHANG 16APR2015		Harrisburg, PA 17105-3608	
Ø		1 PLC ±0.5		APPV: H. GUO 16APR2015		NAME: Ocean End Feed Applicator	
H		2 PLC ±0.13		PRODUCT SPEC		SIZE: CAGE CODE: DRAWING NO: RESTRICTED TO	
D		3 PLC ±0.013		APPLICATION SPEC		A11 00779 ©=2150546	
R		4 PLC ±0.001		WEIGHT		SCALE: 1:1 SHEET 2 OF 4 REV A	
ANGLES		±.1		Customer Accessible Production Drawing		SHEETS 3 & 4 ARE NOT REQUIRED FOR ATLANTIC VERSION	
FINISH		-		-		-	

PACIFIC VERSION TERMINATOR INTERFACE ADAPTER	PART NUMBER	REVISION	DESCRIPTION	FEED TYPE	APPLICATOR STYLE CONVERSION CHART						
					CONVERT TO	PART NUMBERS REQUIRED					
	2-2150546-1	A	FINE CRIMP HEIGHT ADJUST	MECHANICAL	PNEUMATIC FEED	2119950-1	2119792-2	-	2119641-2	-	2063440-1
					SERVO LATCH PLATE	2119951-1	1901697-1	8-2150546-5	-	-	2168400-7 (QUANTITY 2)
					SMART APPLICATOR	2161326-1	-	8-2150546-4	-	-	-
	2-2150546-2	A	FINE CRIMP HEIGHT ADJUST	PNEUMATIC	MECHANICAL FEED	2119949-1	2063961-1	5-18022-5	2119653-2	-	-
					SERVO LATCH PLATE	2119951-1	1901697-1	8-2150546-5	-	-	2168400-7 (QUANTITY 2)
					SMART APPLICATOR	2161326-1	-	8-2150546-4	-	-	-
	2-2150546-5	A	FINE CRIMP HEIGHT ADJUST	SERVO LATCH PLATE	MECHANICAL FEED	2119949-1	2063961-1	5-18022-5	2119653-2	-	-
					PNEUMATIC FEED	2119950-1	2119792-2	-	2119641-2	-	2063440-1
	2-2150546-7	A	FINE CRIMP HEIGHT ADJUST	NONE	-	-	-	-	-	-	-
	7-2150546-7	A	CRIMP TOOLING KIT	-	-	-	-	-	-	-	-

APPLICATOR DATA		
CRIMP SIZE	TYPE	
WIRE 1.57 mm (.062)	F	
INSUL 1.78 mm (.070)	Ø	
APPL INSTRUCTIONS 408-10390		

TERMINAL DATA: TE TERMINAL		TE CRIMP SPECIFICATION
TERMINAL NAME: FASTON RECEPTACLE .110 SERIES		
WIRE STRIP LENGTH 5.21-5.97 mm (.205-.235 IN)		INSULATION DIAMETER RANGE Ø1.02-1.52 mm (.040-.060 IN)
TERMINAL APPLICATION SPECIFICATION	114-2036	
TERMINALS APPLIED		
TE TERMINAL	TE TERMINAL	TE TERMINAL
140716-2		

WIRE SIZE	CRIMP HEIGHT mm [INCH]	CRIMP HEIGHT REFERENCE SETTING
22 AWG OR 0.30mm2	0.81+/-0.05 [.032+/-0.002]	8.1
24 AWG OR 0.20mm2	0.76+/-0.05 [.030+/-0.002]	8.6

- RECOMMENDED SPARE PARTS
- GREASE BEARING SURFACES LIGHTLY
- LUBRICATE DAILY PER THE APPLICATOR INSTRUCTION SHEET SUPPLIED WITH THE APPLICATOR.
- APPLICATOR SPECIFIC DATA TO BE ENTERED INTO BLANK MEMORY CHIP AT ASSEMBLY. SEE BELOW FOR PART NUMBER:  
 MECHANICAL FEED WITH "SMART APPLICATOR" CONVERSION: 8-2150546-4  
 PNEUMATIC FEED WITH "SMART APPLICATOR" CONVERSION: 8-2150546-4  
 SERVO FEED WITH "FINE CRIMP HEIGHT ADJUST": 8-2150546-5
- ADJUSTMENT OF THE STRIPPER MAY BE REQUIRED WHEN MOVING THE APPLICATOR BETWEEN BENCH AND LEADMAKER APPLICATIONS.
- APPLY PART NUMBER 1-23419-5 LOCTITE TO THREADS OF ITEMS 62 & 180.  
 APPLY PART NUMBER 2-23419-6 LOCTITE TO THREADS OF ITEM 242.
- GREASE THREADS, GROOVE AND O-RING ON ITEMS 139 & 153.
- MAGNET, ITEM 166 MUST BE ORIENTED CORRECTLY IN ORDER TO PROPERLY ACTUATE THE COUNTER.
- CRIMP HEIGHT REFERENCE SETTING WAS THE SETTING USED WHEN THE APPLICATOR WAS QUALIFIED AT THE FACTORY. ADJUSTMENT MAY BE NECESSARY WHEN RUNNING APPLICATOR IN THE FIELD.
- SPARE FEED CAM STORAGE LOCATION REFER TO INSTRUCTION SHEET FOR ADDITIONAL INFORMATION.
- THE RECOMMENDED SET-UP FOR END FEED APPLICATORS IS POST-FEED WITH ITEM 2119653-1. THE APPLICATOR CAN BE CONFIGURED FOR PRE-FEED WITH ITEM 2119652-1 BUT MAY ENCOUNTER PROBLEMS WITH SOME APPLICATIONS. FEED ISSUES OR TERMINAL JAMMING MAY OCCUR IN THE PRE-FEED CONFIGURATION.

**\*WARNING**  
 ON INSTALLATION, SET WIRE DISC, ITEM 40 TO LARGEST WIRE SIZE SETTING. USE OF SETTINGS BELOW MINIMUM REQUIRED CRIMP HEIGHT SETTING WILL CAUSE DAMAGE TO CRIMP TOOLING.

-	1	1	1	1	2119782-1	FINE ADJUST HEAD ASM, PACIFIC STYLE	251
-	-	-	1	-	2119640-1	PUSH ROD, AIR FEED	250
-	-	-	1	-	2079988-1	BUSHING, LCH5-12, MISUMI	249
-	1	1	1	1	1-22279-3	SPRING, COMPRESSION	246
-	1	1	1	1	2119082-4	CAM, SNAIL, INSULATION ADJUSTMENT	244
-	1	1	1	1	2079764-1	WASHER, WAVE SPRING, CREST-TO-CREST	243
-77-	27-	25-	22-	21	PART NO	DESCRIPTION	ITEM NO

**PACIFIC VERSION**  
 Shown on sheets 3 of 4 & 4 of 4  
 (Atlantic version shown on sheets 1 of 4 & 2 of 4)

SET UP GAUGE	LOC	DIST	REVISIONS			
2119599-2	A	66	REV	DATE	BY	APPV
			-	SEE SHEET 1	-	-

△	-	1	1	1	1	2119083-1	RETAINER, INSULATION DIAL	242
	-	-	2	-	-	2168400-7	SHCS, LOW HEAD, RoHS, M5 X 10	240
	-	-	-	-	1	2119580-1	MECHANICAL FEED ASSEMBLY	239
	-	-	-	1	-	2063440-1	AIR FEED MODULE	238
	-	-	1	-	-	2119740-2	TAG, IDENTIFICATION	213
	-	4	4	4	4	2079383-9	SCR, BHSC, RoHS (M6 X 20)	186
	-	-	REF	-	-	1901697-1	FEED FINGER ASSEMBLY, EF	183
△	-	1	1	1	1	1-1752354-0	STANDOFF, HOLD-DOWN	180
	-	1	1	1	1	6-993111-6	PIN, SLOTTED SPRING 3.0 X 14.0	177
	-	1	1	1	1	8-22280-7	SPRING, COMPRESSION	176
	-	1	1	1	1	1752353-2	GUIDE PIN, HOLDDOWN	175
	-	1	1	1	1	1901680-2	GUIDE PIN, HOLDDOWN	174
	-	-	-	2	-	21045-3	RING, RETAIN, EXTERN, 3/16 CRESCENT	172
	-	1	1	1	1	994969-1	MAGNET, RARE EARTH HIGH ENERGY	166
	-	REF	REF	REF	REF	994970-2	COUNTER, MAGNETIC	164
	-	-	-	1	-	240638-1	SPRING, FEED FINGER	163
	-	1	1	1	1	8-21084-1	O-RING, .801 ID, .070 DIA. MAT.	153
	-	-	-	1	-	2119641-2	FEED CAM, AIR FEED	152
	-	1	1	1	1	2119798-2	DETENT PIN	145
	-	1	1	1	1	2079383-8	SCR, BHSC, RoHS (M4 X 16)	144
	-	-	-	-	1	2119653-2	FEED CAM, POST FEED	142
	-	1	1	1	1	2119655-6	APPLICATOR BASIC ASSEMBLY, EF	141
	-	1	1	1	1	2119651-1	RAM, ASIAN STYLE, END FEED	140
	-	1	1	1	1	2119092-2	BOLT, ADJUSTMENT	139
	-	-	-	1	-	3-23627-7	PIN, RETAIN, GRVD, 3/16 X .854	137
	-	-	REF	-	-	SEE NOTE 4	MEMORY CHIP, PROGRAMMED	135
	-	-	1	-	-	1633743-1	SERVO FEED LATCH ASM	133
	-	1	1	1	1	455888-5	SPACER, CRIMPER	82
	-	1	1	1	1	2119956-2	DOCUMENTATION PACKAGE	71
	-	2	2	2	2	2-18032-2	SCR, SET, FLT POINT M3 X 10.0	70
	-	1	-	1	1	2119740-1	TAG, IDENTIFICATION	67
	-	2	2	2	2	2168078-1	SCREW, DRIVE, RH, RoHS, 2 x .188	66
	-	1	1	1	1	1901681-5	HOLDDOWN, TERMINAL	65
	-	2	2	2	2	2168400-8	SHCS, LOW HEAD, RoHS, M4 X 16	64
	-	1	1	1	1	2119793-1	LIMITER, ADJUSTMENT BOLT	63
△	-	3	3	3	3	992763-5	SCR, SET, SOC, CONE POINT, M3 X 4.0	62
	-	-	-	-	1	5-18022-5	SCR, HEX HD CAP, M4 X 6.0	59
	-	-	-	-	1	2063961-1	FEED FINGER	58
	-	3	3	3	3	2168400-4	SHCS, LOW HEAD, RoHS, M4 X 8	57
	-	2	2	2	2	2168083-2	SCR, SKT HD CAP, RoHS, M4 X 8.0	56
	-	2	2	2	2	5018030-2	NUT, HEX, REG, RoHS, M4	55
	-	2	2	2	2	5018030-1	NUT, HEX, REG, RoHS, M3	54
	-	2	2	2	2	986965-8	NUT, LOCK, HEX, TORQUE (M4)	53
	-	1	1	1	1	1-5018030-0	NUT, HEX, REG, RoHS, M3.5	52
	-	-	-	1	-	2119792-2	PAWL, EF, AIR	51
	-	-	-	1	2	18023-9	SCR, SKT HD CAP M4 X 6.0	49
	-	-	-	-	1	2119652-1	FEED CAM, PRE FEED	48
	-	1	1	1	1	2079383-7	SCR, BHSC, RoHS (M8 X 25)	41
	-	1	1	1	1	2119645-1	DISC, NUMBERED FA WIRE ADJUSTMENT	40
	-	1	1	1	1	2119957-1	APPLICATOR SHIM PACK	39
	-	1	1	1	1	1-2119644-4	RAM WASHER, PRECISION	38
	-	7	7	7	7	1-18028-2	WASHER, FLAT, REG M4	33
	-	2	2	2	2	2168083-9	SCR, SKT HD CAP, RoHS, M4 X 20	31
	-	2	2	2	2	1-2168083-0	SCR, SKT HD CAP, RoHS, M4 X 10	29
	-	1	1	1	1	240639-1	STRIPPER (MACHINING)	27
	-	2	2	2	2	1320906-1	STUD, THREADED	25
	-	1	1	1	1	1752371-5	PLATE, STRIP GUIDE	24
	-	1	1	1	1	1-240825-1	PLATE, STRIP HOLD DOWN	23
	-	2	2	2	2	2-22281-3	SPRING, COMPRESSION	22
	-	1	1	1	1	1752373-4	DRAG	20
	-	2	2	2	2	1901259-2	GUIDE, LOWER STRIP	18
	-	1	1	1	1	1752360-1	SPACER, HOLD-DOWN	13
△	-	1	1	1	1	240644-1	PLATE, REAR SHEAR	11
	-	-	-	-	-	-	-	10
△	-	1	1	1	1	690482-6	PLATE, FRONT SHEAR	9
△	1	1	1	1	1	1333214-5	ANVIL, EF .062	8
△	-	1	1	1	1	2217206-4	BLADE, SLUG	7
	-	-	-	-	-	-	-	6
	-	1	1	1	1	3-240641-0	SPACER	5
	-	1	1	1	1	238009-1	BLOCK, FL CRIMPER SPACER	4
△	1	1	1	1	1	6-1803018-8	CRIMPER, INSULATION O	3
	-	1	1	1	1	455888-7	SPACER, CRIMPER	2
△	1	1	1	1	1	1-456403-5	CRIMPER, WIRE PREMIUM	1
-77-	27-	25-	22-	21	PART NO	DESCRIPTION	ITEM NO	

DIMENSIONS:		TOLERANCES UNLESS OTHERWISE SPECIFIED:		DATE	BY	APPV	NAME
mm	0 PLC ±.5	1 PLC ±.13	2 PLC ±.013	16APR2015	J. HOU	L. ZHANG	TE Connectivity Harrisburg, PA 17105-3608
	3 PLC ±.013	4 PLC ±.0001	ANGLES	16APR2015	W. GUO		Ocean End Feed Applicator
MATERIAL:	FINISH:	WEIGHT:	SCALE:	SIZE:	CAGE CODE:	DRAWING NO:	RESTRICTED TO:
			Customer Accessible Production Drawing	A1	00779	©=2150546	

LOC		DIST		REVISIONS			
A	66	P	LTM	DESCRIPTION	DATE	OWN	APVD
		-	-	SEE SHEET 1	-	-	-

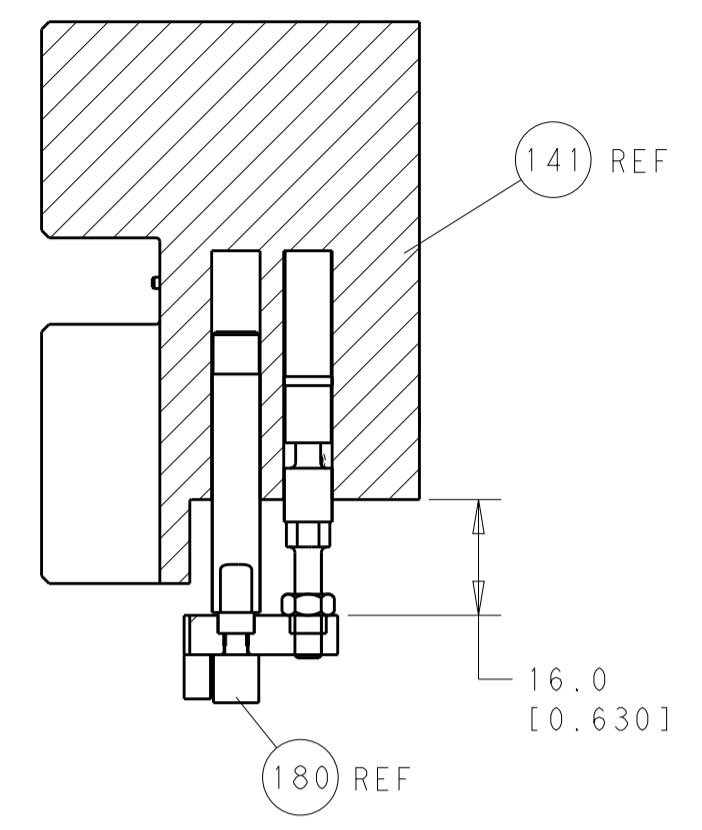

HOLDDOWN SET-UP

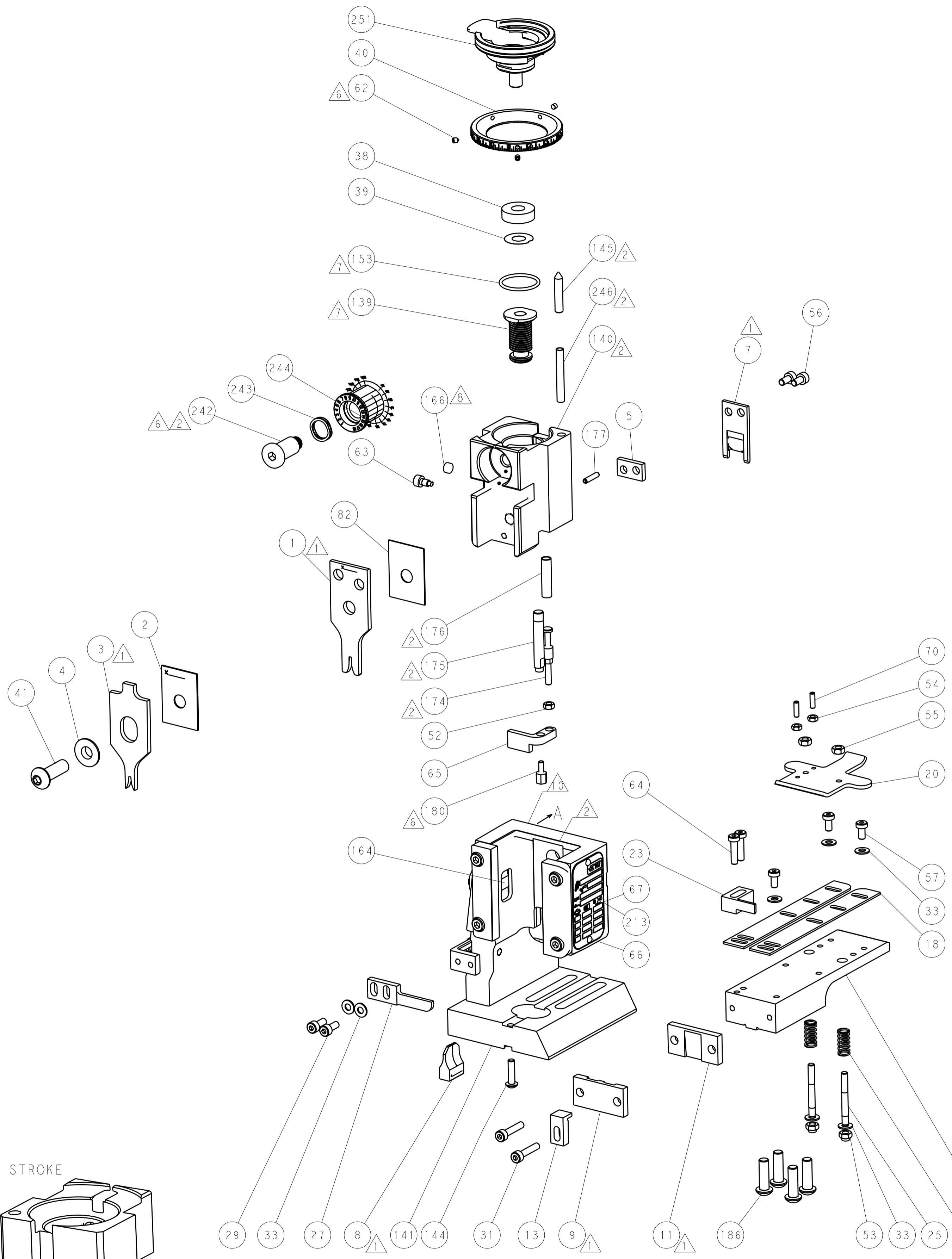

FEED TYPE  
MECHANICAL

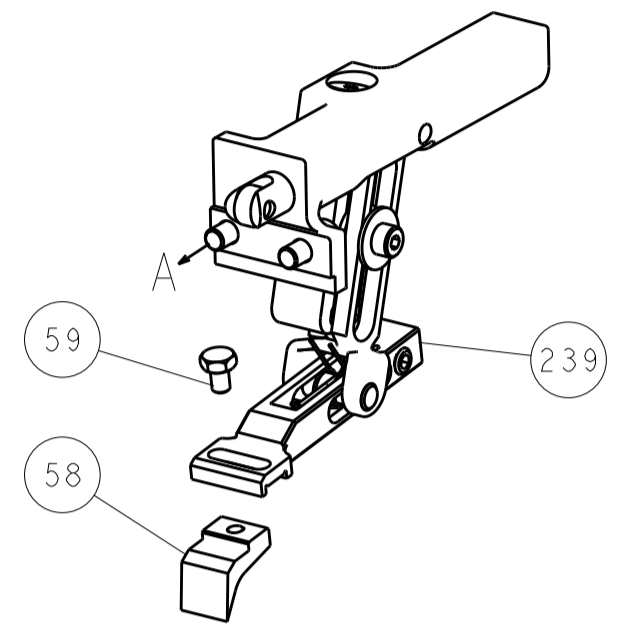

PNEUMATIC

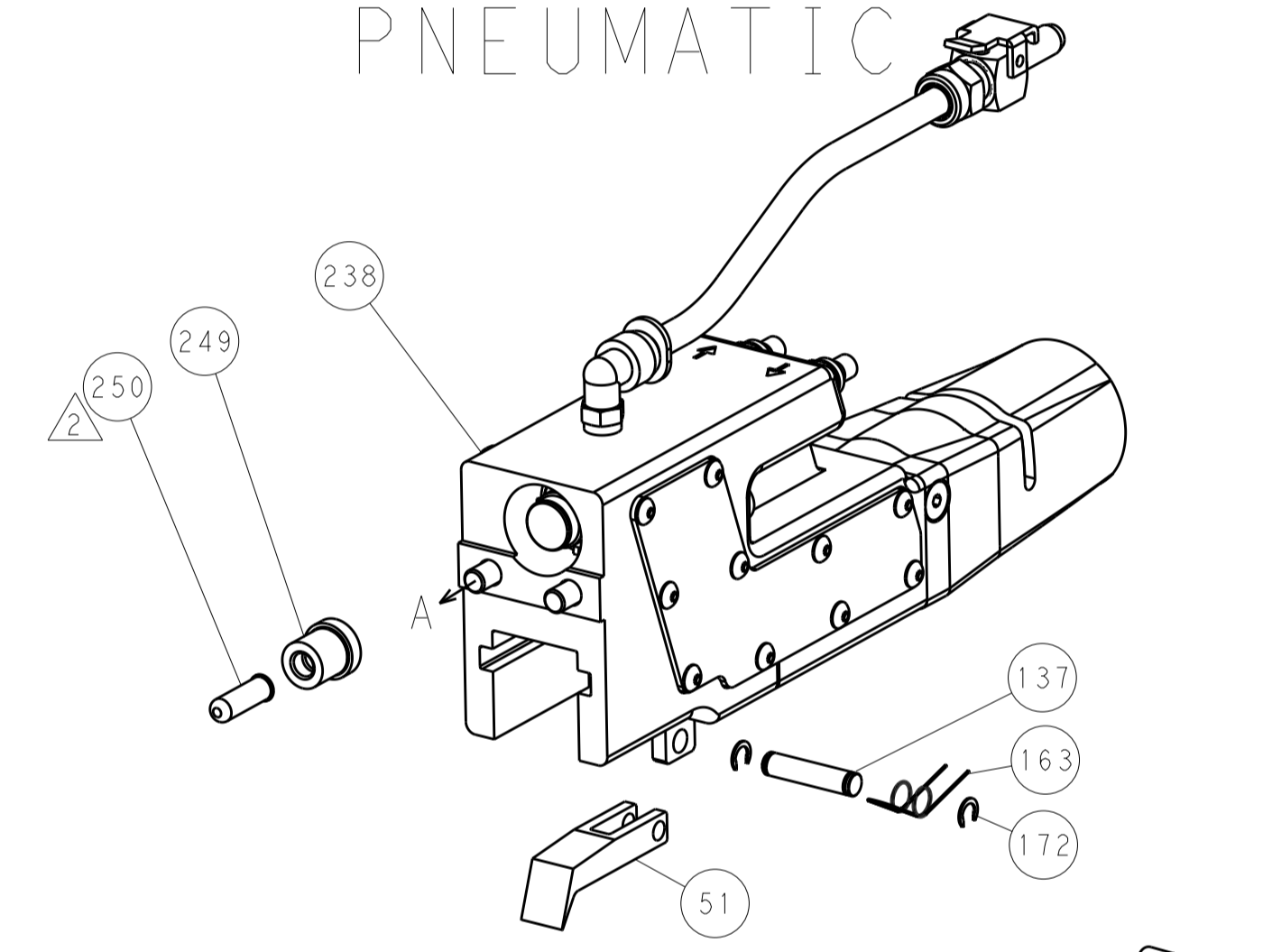

SERVO  
LATCH PLATE

CAM POSITIONS

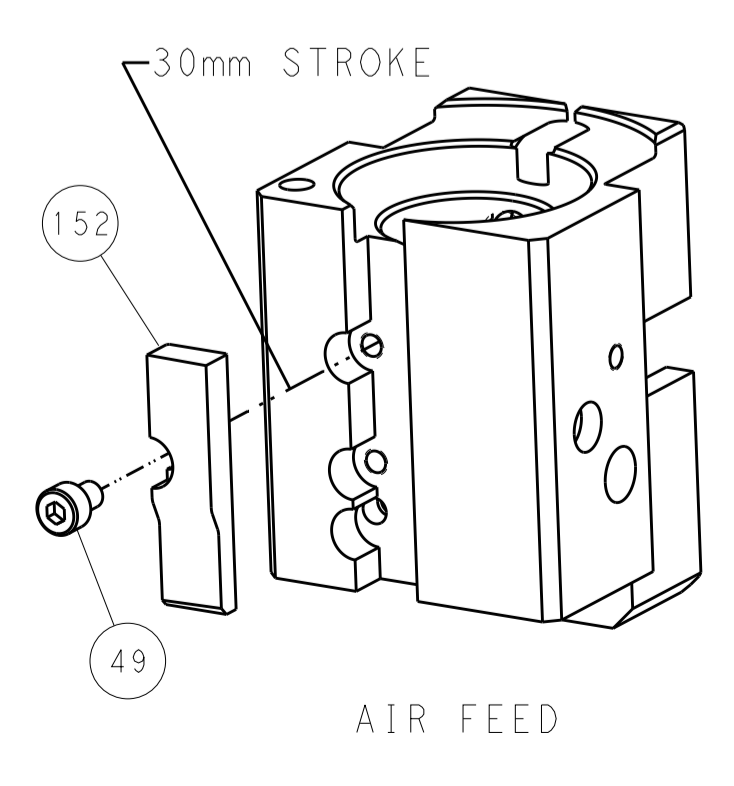
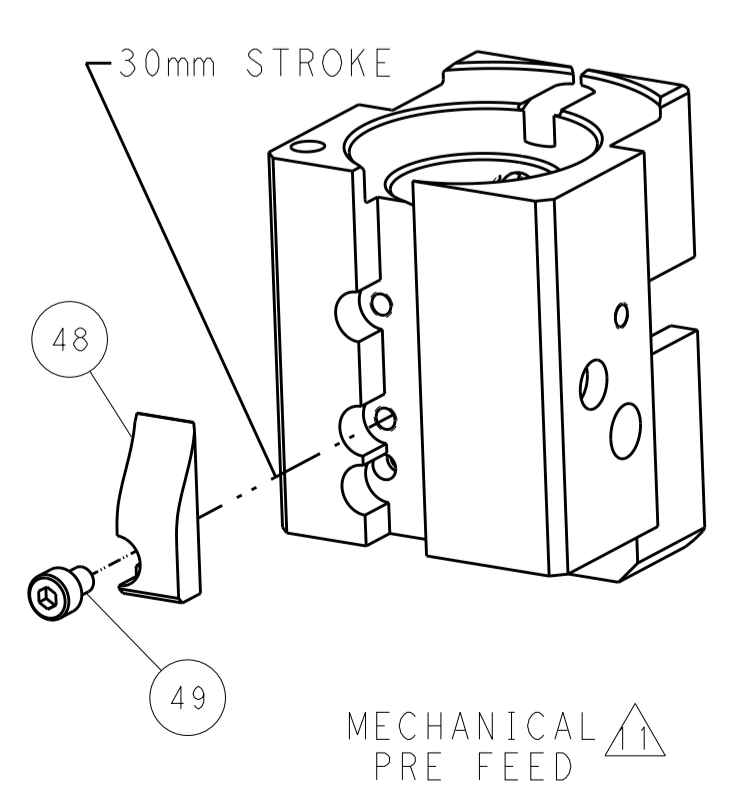
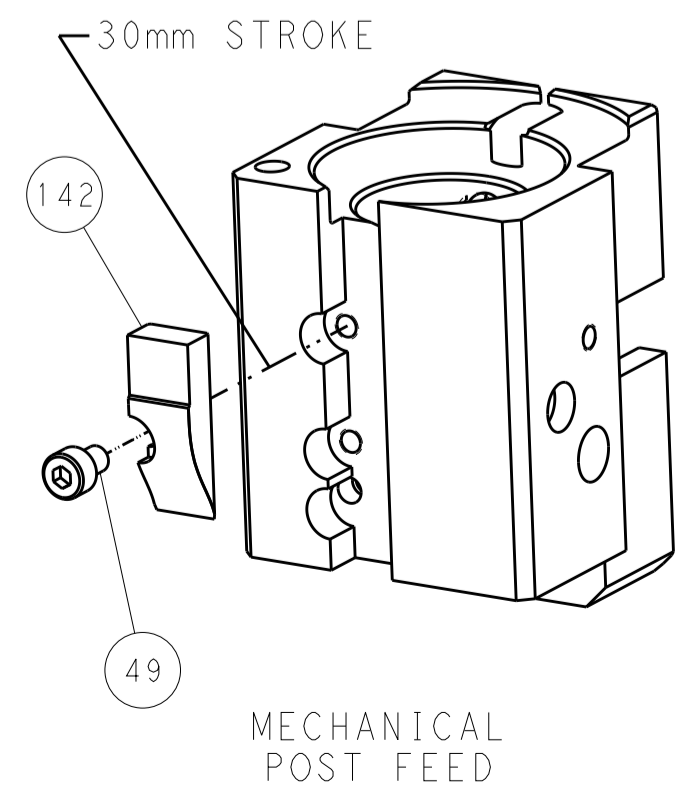

PACIFIC VERSION  
Shown on sheets 3 of 4 & 4 of 4  
(Atlantic version shown on sheets 1 of 4 & 2 of 4)

DIMENSIONS:		TOLERANCES UNLESS OTHERWISE SPECIFIED:		DWN: J. HOU 16APR2015		CHK: L. ZHANG 16APR2015		APVD: H. GUO 16APR2015		NAME: Ocean End Feed Applicator	
mm	0 PLC ±0.5	1 PLC ±0.13	2 PLC ±0.013	3 PLC ±0.001	4 PLC ±0.0001	ANGLES	FINISH	WEIGHT	SIZE: A1	CAGE CODE: 00779	DRAWING NO: C=2150546
MATERIAL:		FINISH:		REVISIONS:		SCALE: 1:1		SHEET: 4		REV: A	