

PART NUMBER	INSERT COLOR & WIRING	HOUSING FINISH
EHFw800X2	RED - CROSS WIRED	NICKEL
EHFw800X2B	RED - CROSS WIRED	BLACK CHROME

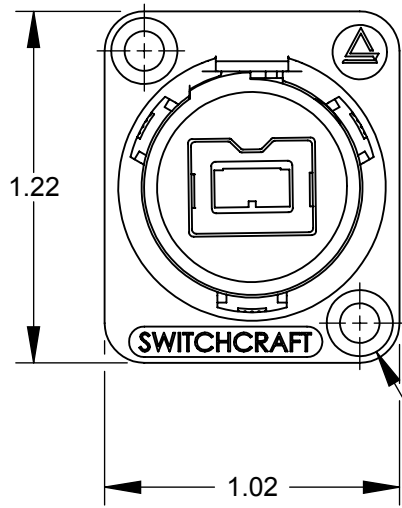

Ø0.138 THRU  
 ✓ Ø0.230 X 82°  
 (2) PLACES

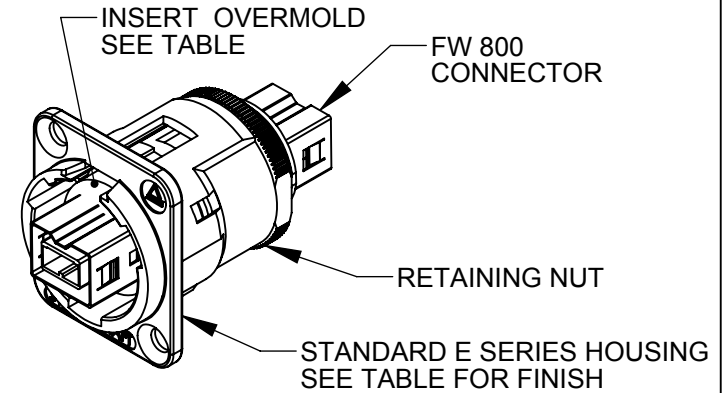
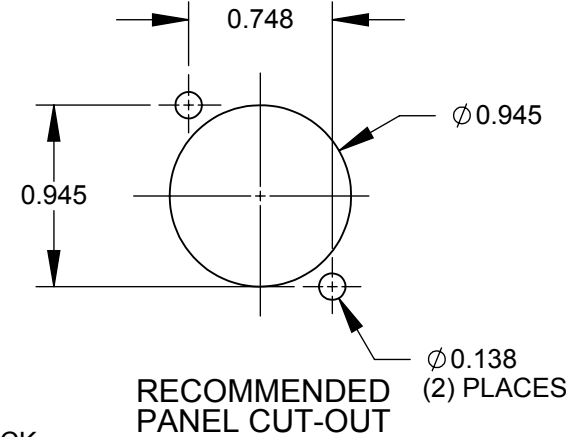
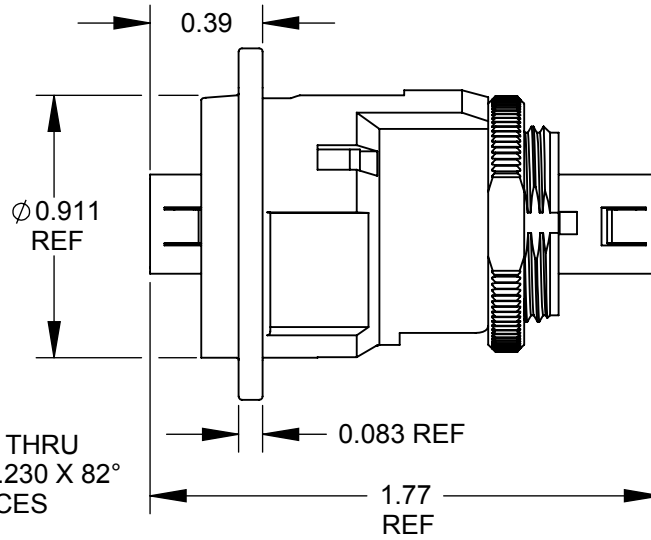

PIN ASSIGNMENT									
<b>EHFw800X2 &amp; EHFw800X2B</b>									
CROSS WIRED									
1	2	3	4	5	6	7	8	9	SHIELD
						NC			
3	4	1	2	9	6	7	8	5	SHIELD



**NOTES:**

1. MATERIALS:  
 INSERT OVERMOLD - THERMOPLASTIC, BLACK  
 RETAINING NUT - BRASS, NICKEL PLATED  
 HOUSING - ZINC ALLOY
2. THERE IS NO CONNECTION BETWEEN PINS 7 AND 7.
3. THIS PRODUCT IS RoHS COMPLIANT.

**CUSTOMER DRAWING**

					THIS DRAWING DESCRIBES A DESIGN CONSIDERED PROPRIETARY IN NATURE, DEVELOPED AND MANUFACTURED BY SWITCHCRAFT INC. AND IS RELEASED ON A CONFIDENTIAL BASIS FOR IDENTIFICATION PURPOSES ONLY.					
					SIZE	WIDTH	MULT	LBS/M	TEMPER	
					FINISH			MATERIAL		
					SPEC No.			SPEC No.		
					FIRST USED ON		SCALE 1.5:1			
D	26611	09/08/10	JEB	TJK	DATE DRAWN	BY	CHKD	APVD	<b>Switchcraft®</b>	
C	26467	11/30/09	RS	TJK	1/9/08	JGK	RS	TJK		
B	26415	7/17/09	TJK	TJK			5/1/09	5/1/09		
A	26308	12/1/08	RS	TJK	SHEET 1 OF 1					
REV	ECO NUMBER	DATE	BY	APVD	NAME				PART No.	REV
REVISIONS					FIREWIRE 800 FEED-THRU SERIES				EHFw800 SERIES	D

DO NOT SCALE DRAWING

SolidWorks CAD File

