

THIS DRAWING IS UNPUBLISHED. RELEASED FOR PUBLICATION
 © COPYRIGHT - By - ALL RIGHTS RESERVED.

REVISIONS					
P	LTR	DESCRIPTION	DATE	DWN	APVD
	H1	REVISED PER ECO-11-004917	11MAR11	RK	HMR
	H2	REVISED PER ECO-17-007400	28NOV2017	RS	DR

AMP WIRE RANGE	Listed	LR7189 Certified
12-10 AWG SOLID OR STRANDED	12-10 AWG SOLID OR STRANDED	12-10 AWG SOLID OR STRANDED

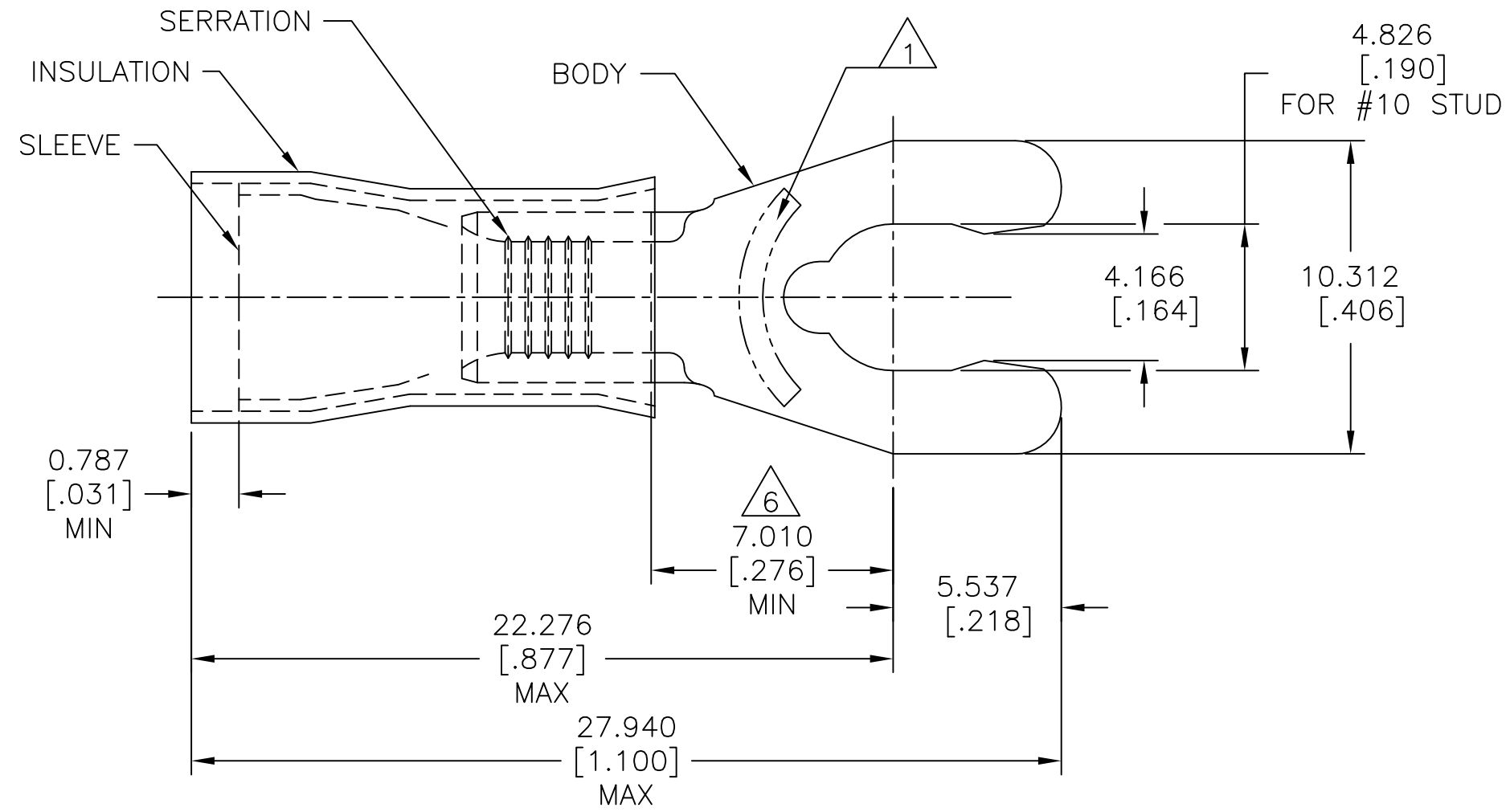

- 1 STAMP 10S AMP 12-10* APPROX AS SHOWN
- 2 WIRE INSULATION $\phi 3.810-6.350[\phi .150-.250]$
- 3 BODY MATERIAL THICKNESS $0.991 \pm 0.051[.039 \pm .002]$
- 4 MATERIAL: BODY - PHOS BRONZE PER ASTM B103
INSULATION - NYLON,
METAL SLEEVE - COPPER PER ASTM B152.
- 5 FINISH: BODY - TIN PLATE PER ASTM B545
METAL SLEEVE - TIN PLATE PER ASTM B545
INSULATION - COLOR- YELLOW.
- 6 APPLIES FROM EDGE OF METAL WIRE
BARREL TO CENTER OF STUD.

2500	ON TAPE	52943-1
500	LOOSE PIECE	52943
QTY	PACKAGE TYPE	PART NO

AMP INCORPORATED CUSTOMER SERVICE SYSTEMS		MAX RECOMMENDED OPERATING TEMPERATURE: 105°C [221°F]	THIS DRAWING IS A CONTROLLED DOCUMENT.		DWN jr_ruth 20MAR07	TE Connectivity				
FOR ADDITIONAL PRODUCT INFORMATION OR COPIES OF DRAWINGS AND TECHNICAL DOCUMENTS	PRODUCT INFORMATION CENTER 1-800-522-6752	VOLTAGE RATING: 300 V MAX	DIMENSIONS: mm [INCHES]	TOLERANCES UNLESS OTHERWISE SPECIFIED:	CHK T MICHELUTTI 20MAR07				NAME TERMINAL, SPRING SPADE, STUB, PIDG WIRE SIZE: 12-10	
FOR APPLICATION TOOLING INFORMATION	TOOLING ASSISTANCE CENTER 1-800-722-1111	CIRCULAR MIL AREA: 2.62-6.64mm ² [5,180-13,100] SOLID OR STRANDED		0 PLC ± - 1 PLC ± - 2 PLC ± - 3 PLC ± 0.127[.005] 4 PLC ± - ANGLES ± 5°	APVD T MICHELUTTI 20MAR07	PRODUCT SPEC UL 486 A-B	SIZE	CAGE CODE	DRAWING NO	RESTRICTED TO
FOR ORDER ENTRY	1-800-526-5142	THIS DRAWING IS A CONTROLLED DOCUMENT FOR AMP INCORPORATED. IT IS SUBJECT TO CHANGE AND THE CONTROLLING ENGINEERING ORGANIZATION SHOULD BE CONTACTED FOR THE LATEST REVISION.	MATERIAL 4	FINISH 5	APPLICATION SPEC 114-2157	WEIGHT -	A3	00779	C=52943	-
CUSTOMER DRAWING						SCALE	5:1	SHEET	1 OF 1	REV H2