

THIS DRAWING IS UNPUBLISHED. RELEASED FOR PUBLICATION 20
 © COPYRIGHT 20 BY - ALL RIGHTS RESERVED.

LOC	DIST	REVISIONS					
AF	50	P	LTR	DESCRIPTION	DATE	DWN	APVD
		B5		REVISED PER ECO-18-007263	09MAY2018	RS	DS
		B6		REVISED PER ECR-19-006167	07MAY2019	BDA	DH
		B7		REVISED PER ECR-19-017221	28JAN2020	BDA	DS
		C		REVISED PER ECN-22-147652	08APR2022	MK	ES

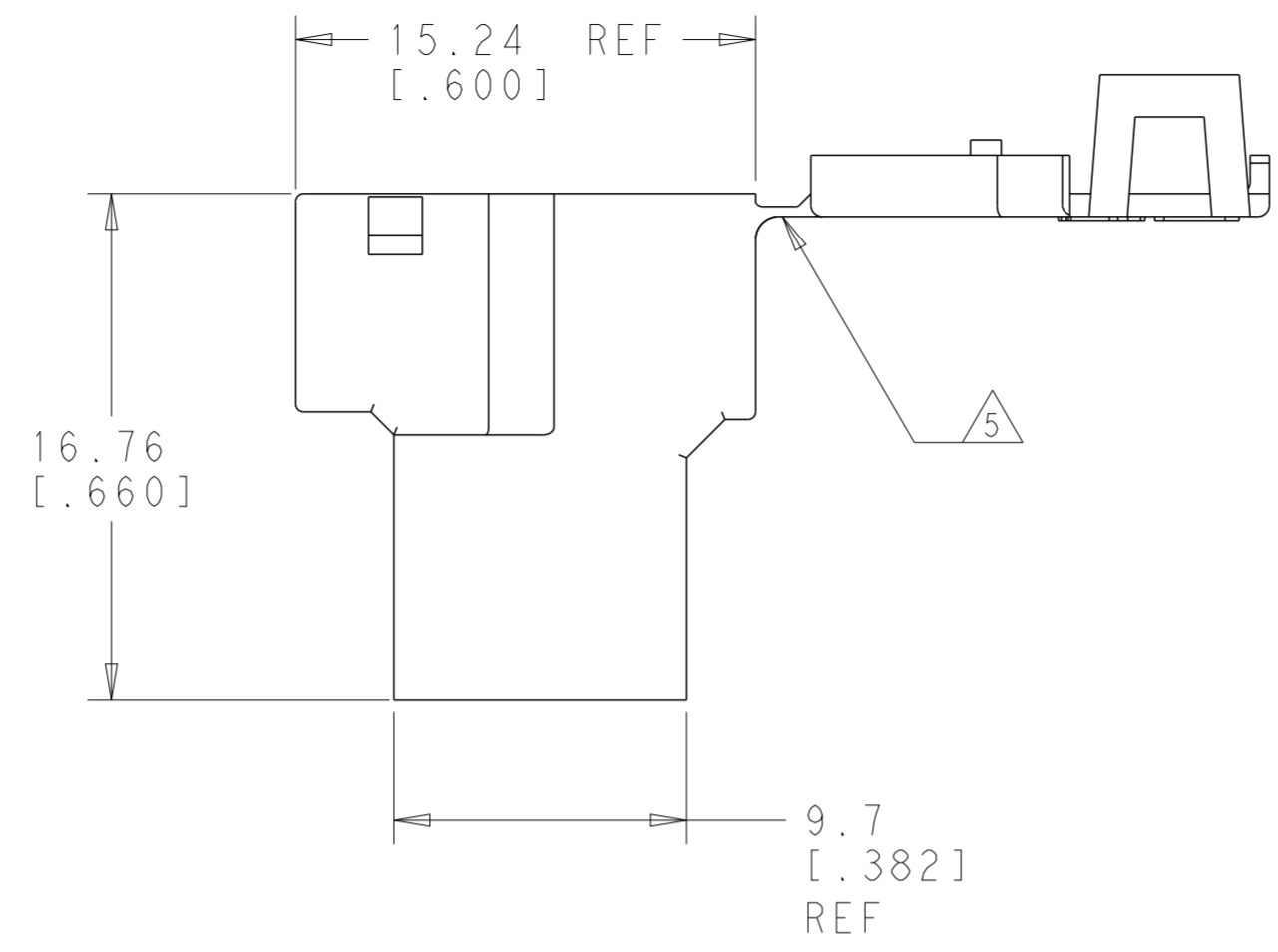

- ① MATERIAL -NATURAL, 6 NYLON, 150°C, V0
- ② MATERIAL -BLACK, 6 NYLON, 150°C, V0
- ③ MATERIAL -NATURAL, 66 NYLON, V2, GLOW WIRE MATERIAL
- ④ MATERIAL - NATURAL 66 NYLON V0, GLOW WIRE MATERIAL
- 5 REFER TO SPECIFICATION 408-143119 FOR GUIDANCE ON RE-MOISTURIZATION AND PART STORAGE

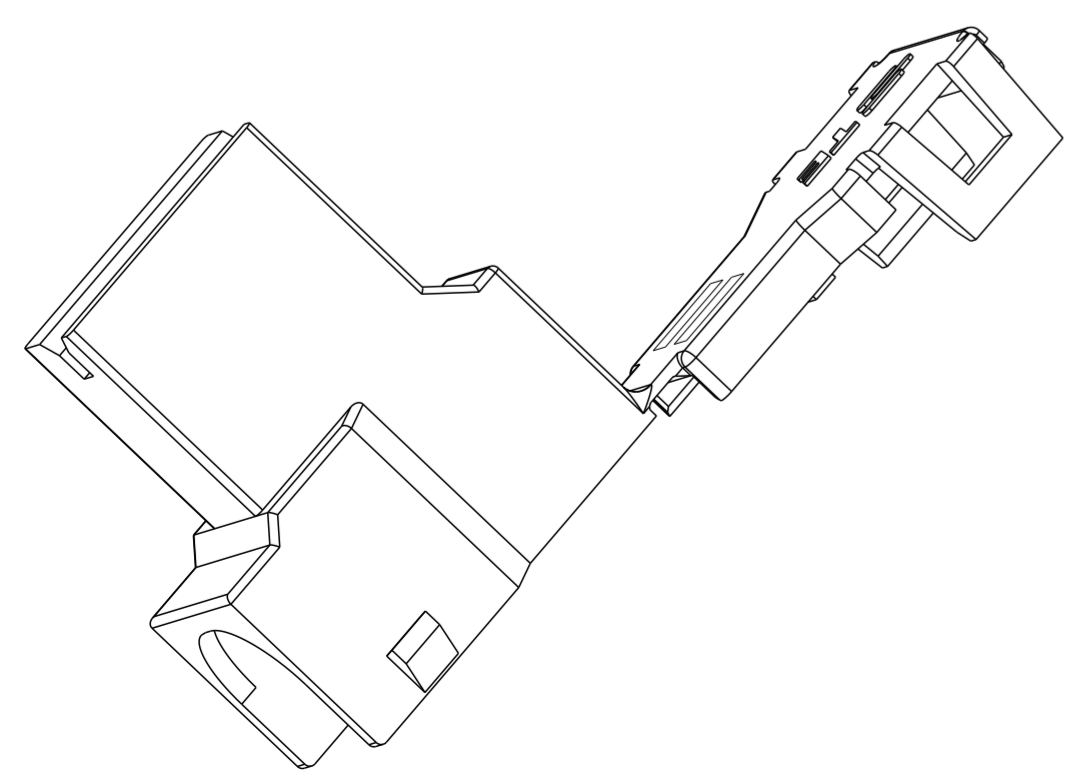
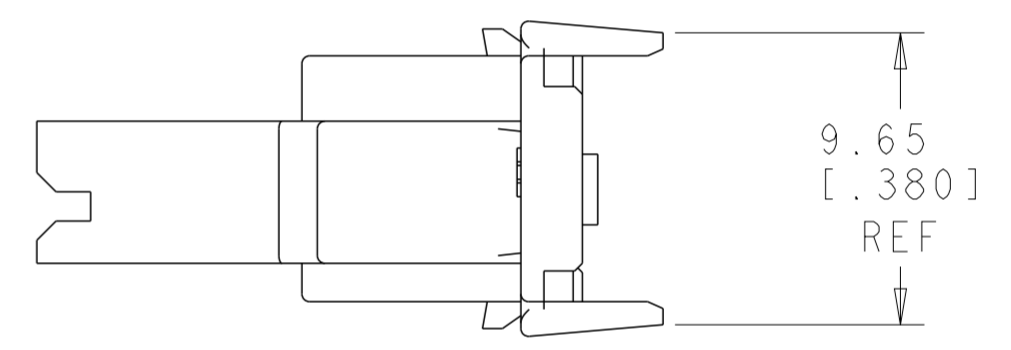
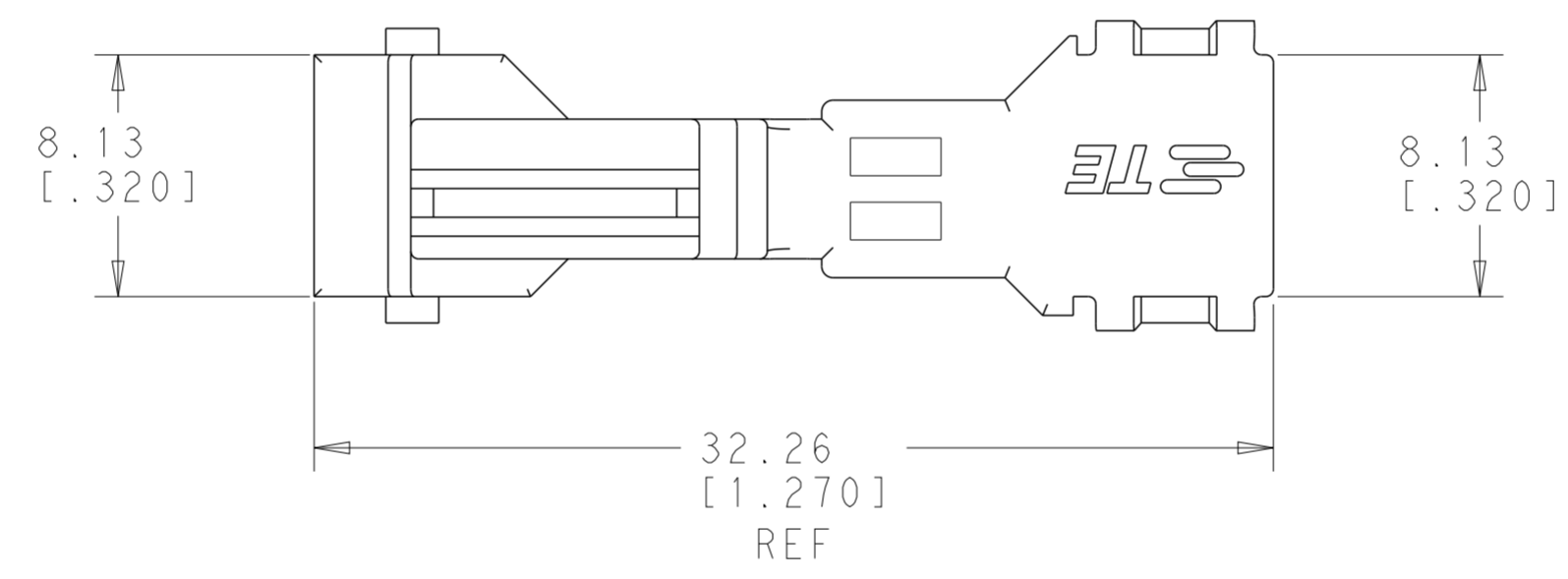
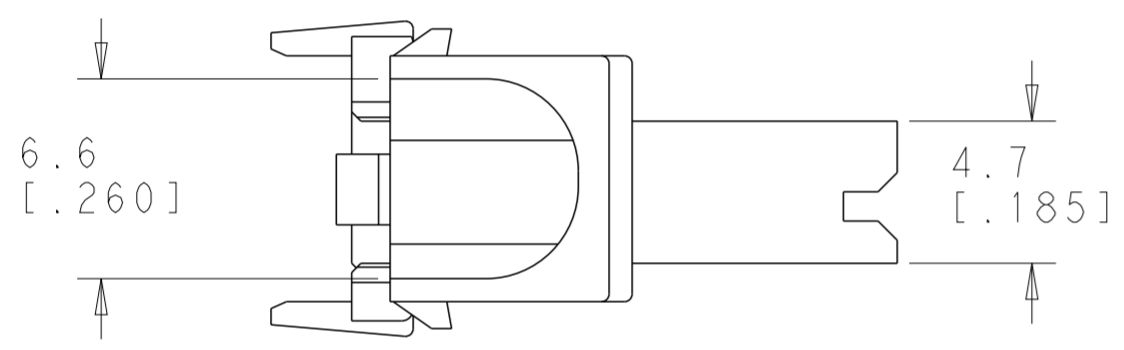

SUPERSEDED BY 1969507-9

④	1969507-9
③	1969507-4
②	1969507-3
①	1969507-2
MATERIAL	PART NO.

THIS DRAWING IS A CONTROLLED DOCUMENT.		DWN	JR RUTH	03APR12	TE Connectivity	NAME			HOUSING, RECEPTACLE, FLAG FASTON, CLOSED BACK, .250 SERIES										
DIMENSIONS: mm [INCHES]		CHK	PETE DESANTIS	03APR12		PRODUCT SPEC			SIZE	CAGE CODE	DRAWING NO	RESTRICTED TO							
TOLERANCES UNLESS OTHERWISE SPECIFIED:		APVD	PETE DESANTIS	03APR12		APPLICATION SPEC			A2	00779	C-1969507	-							
0 PLC ±		MATERIAL		FINISH		WEIGHT			CUSTOMER DRAWING			SCALE	4:1	SHEET	1	OF	1	REV	C
1 PLC ±		SEE TABLE																	
2 PLC ±0.38 [.015]																			
3 PLC ±																			
4 PLC ±																			
ANGLES ±																			