

REVISIONS					
REV	ECO	DESCRIPTION	DATE	BY	APPR
B1	-	RELEASED DRAWING	Nov-17-2014	Ben	Tommy
B2	-	VOLTAGE UPDATE AND ADD KEY ICON	Nov-20-2020	Ronald	Tommy

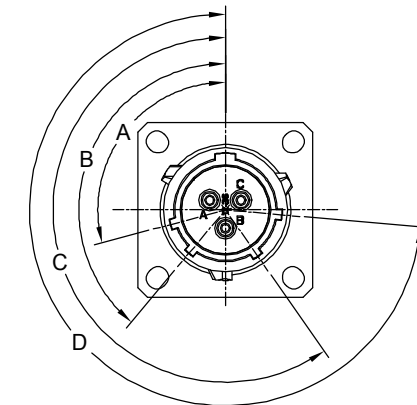

NOTES : (UNLESS OTHERWISE SPECIFIED)

- MATERIAL :
 SHELL : ZINC ALLOY , NICKEL PLATED.
 INSERT : THERMOPLASTIC , UL94 V-0.
 END CAP : THERMOPLASTIC , UL94 V-0.
 PLASTIC BUSHING : THERMOPLASTIC , UL94 V-0.
 SEAL GASKET : NBR/SILICONE RUBBER.
 O-RING : NBR/SILICONE RUBBER.
 WIRE SEAL : SILICONE RUBBER.
- SPECIFICATIONS :
 2.1 RATED CURRENT : 13A (MAX).
 2.2 RATED VOLTAGE : 500V (AC/DC) .
 2.3 OPERATING TEMPERATURE : SEE CHART.
 2.4 DIELECTRIC WITHSTANDING VOLTAGE : LESS THAN
 2 MILLIAMPS CURRENT LEAKAGE@2000 VOLTS AC.
 2.5 INSULATION RESISTANCE : 5000 MEGOHMS MIN.
 2.6 IP--CLASS : IP67 (MATED CONDITION).
 2.7 MATING CYCLES DURABILITY : 500 CYCLES MIN.
 2.8 ROHS COMPLIANT.
- SUITABLE CONTACTS : 16# CONTACTS.
- ALL DIMENSIONS ARE FOR REFERENCE USE ONLY.
- CONTACT SIZE AND REAR SEAL WIRE RANGE :

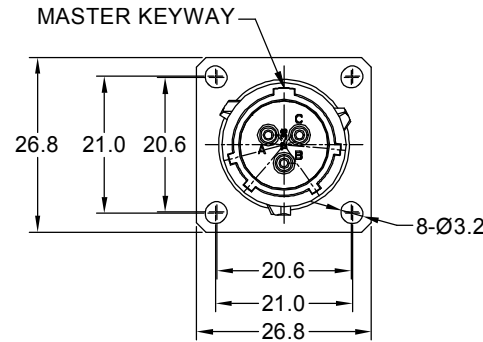
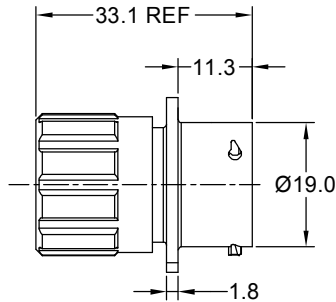
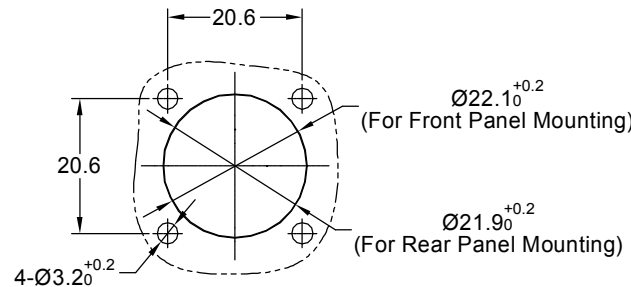

PANEL CUT OUT REFERENCE

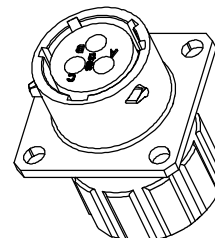

KEY POS	PART NUMBER		A	B	C	D
	-40°C ~ 105°C	-40°C ~ 125°C				
N	RT00123SNHEC	RT00123SNHEC03	105°	140°	215°	265°
W	RT00123SWHEC	RT00123SWHEC03	60°	140°	215°	265°
X	RT00123SXHEC	RT00123SXHEC03	105°	155°	215°	265°
Y	RT00123SYHEC	RT00123SYHEC03	105°	140°	225°	265°
Z	RT00123SZHEC	RT00123SZHEC03	105°	140°	215°	295°

QUANTITY	SEE PART NUMBER CHART	PART NUMBER	DESCRIPTION	ITEM
MATERIALS LIST				
UNLESS OTHERWISE SPECIFIED 1) All dimensions are in metric(mm). 2) Tolerances are as follows: 1 PL DEC ±0.30 2 PL DEC ±0.15 3 PL DEC ±0.08 Fractions ±1/64 Angles ±1° 3) Note reference =		SIGNATURES DRAWN: Ronald Nov-20-2020 CHECKED: Flan Nov-23-2020 ENGINEER: APPROVAL: Tommy Nov-24-2020 CUSTOMER:	Amphenol Sine Systems - www.amphenol-sine.com 44724 Morley Drive Clinton Township, MI 48036	
MATERIAL SPECIFICATIONS: PROCESS SPECIFICATIONS: NEXT ASSY:		THIS DRAWING IS SUPPLIED FOR INFORMATION ONLY. DESIGN FEATURES, SPECIFICATIONS AND PERFORMANCE DATA SHOWN HEREON ARE THE PROPERTY OF THE AMPHENOL CORPORATION. NO RIGHTS OF REPRODUCTION ARE IMPLIED. ALL DIMENSIONS ARE SUBJECT TO NORMAL MANUFACTURING VARIATIONS.		
SIZE: B TYPE: C- SCALE: NONE		DWG NO: RT00123S*HEC REVISION: B2		SHEET 1 OF 1

CONTACT SIZE	MIN. INSUL O.D.	MAX. INSUL O.D.	WIRE RANGE
16#	Ø2.0mm	Ø3.2mm	14 - 24AWG

TITLE: ECOMATE RM,RECEPTACLE SIZE 12,3POS,SOCKET,END CAP
 DWG NO.: RT00123S*HEC
 REV: B2
 SH: 1
 OF: 1