

SLA7029M/SMA7022MU/SMA7029M

2-Phase Excitation

■ Absolute Maximum Ratings

(T_a=25°C)

Parameter	Symbol	Ratings			Unit
		SLA7029M	SMA7022MU	SMA7029M	
Motor Supply Voltage	V _{CC}	46			V
FET Drain-Source Voltage	V _{DSS}	100			V
Control Supply Voltage	V _S	46			V
TTL Input Voltage	V _{IN}	7			V
Reference Voltage	V _{REF}	2			V
Output Current	I _O	1.5	1	1.5	A
Power Dissipation	P _{DI}	4.5 (Without Heatsink)		4.0 (Without Heatsink)	W
	P _{DI}	35 (T _C =25°C)		28 (T _C =25°C)	W
Channel Temperature	T _{ch}	+150			°C
Storage Temperature	T _{stg}	-40 to +150			°C

■ Electrical Characteristics

(T_a=25°C)

Parameter	Symbol	Ratings									Unit
		SLA7029M			SMA7022MU			SMA7029M			
		min.	typ.	max.	min.	typ.	max.	min.	typ.	max.	
Control Supply Current	I _S		10	15		10	15		10	15	mA
	Condition	V _S =44V			V _S =44V			V _S =44V			
Control Supply Voltage	V _S	10	24	44	10	24	44	10	24	44	V
FET Drain-Source Voltage	V _{DSS}	100			100			100			V
	Condition	V _S =44V, I _{OSS} =250μA			V _S =44V, I _{OSS} =250μA			V _S =44V, I _{OSS} =250μA			
FET ON Voltage	V _{DS}			0.6			0.85			0.6	V
	Condition	I _O =1A, V _S =14V			I _O =1A, V _S =14V			I _O =1A, V _S =14V			
FET Drain Leakage Current	I _{DSS}			4			4			4	mA
	Condition	V _{DSS} =100V, V _S =44V			V _{DSS} =100V, V _S =44V			V _{DSS} =100V, V _S =44V			
FET Diode Forward Voltage	V _{SD}			1.1			1.2			1.1	V
	Condition	I _O =1A			I _O =1A			I _O =1A			
TTL Input Current	I _{IN}			40			40			40	μA
	Condition	V _{IN} =2.4V, V _S =44V			V _{IN} =2.4V, V _S =44V			V _{IN} =2.4V, V _S =44V			
	I _{IL}			-0.8			-0.8			-0.8	mA
Condition	V _{IL} =0.4V, V _S =44V			V _{IL} =0.4V, V _S =44V			V _{IL} =0.4V, V _S =44V				
TTL Input Voltage (Active High)	V _{IN}	2			2			2			V
	Condition	I _O =1A			I _O =1A			I _O =1A			
	V _{IL}			0.8			0.8			0.8	
TTL Input Voltage (Active Low)	V _{IN}	2			2			2			V
	Condition	V _{DSS} =100V			V _{DSS} =100V			V _{DSS} =100V			
	V _{OL}			0.8			0.8			0.8	
Switching Time	T _r		0.5			0.5			0.5		μs
	Condition	V _S =24V, I _O =1A			V _S =24V, I _O =0.8A			V _S =24V, I _O =1A			
	T _{sp}		0.7			0.7			0.7		
	Condition	V _S =24V, I _O =1A			V _S =24V, I _O =0.8A			V _S =24V, I _O =1A			
	T _f		0.1			0.1			0.1		
Condition	V _S =24V, I _O =1A			V _S =24V, I _O =0.8A			V _S =24V, I _O =1A				

Internal Block Diagram

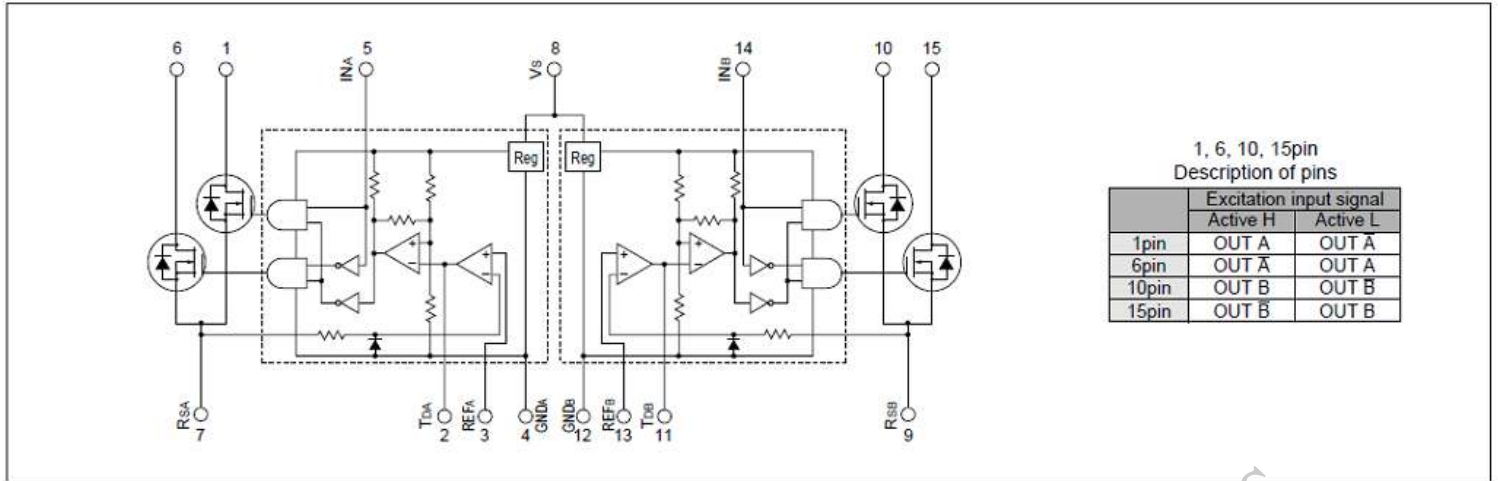

Typical Connection Diagram (Recommended component values)

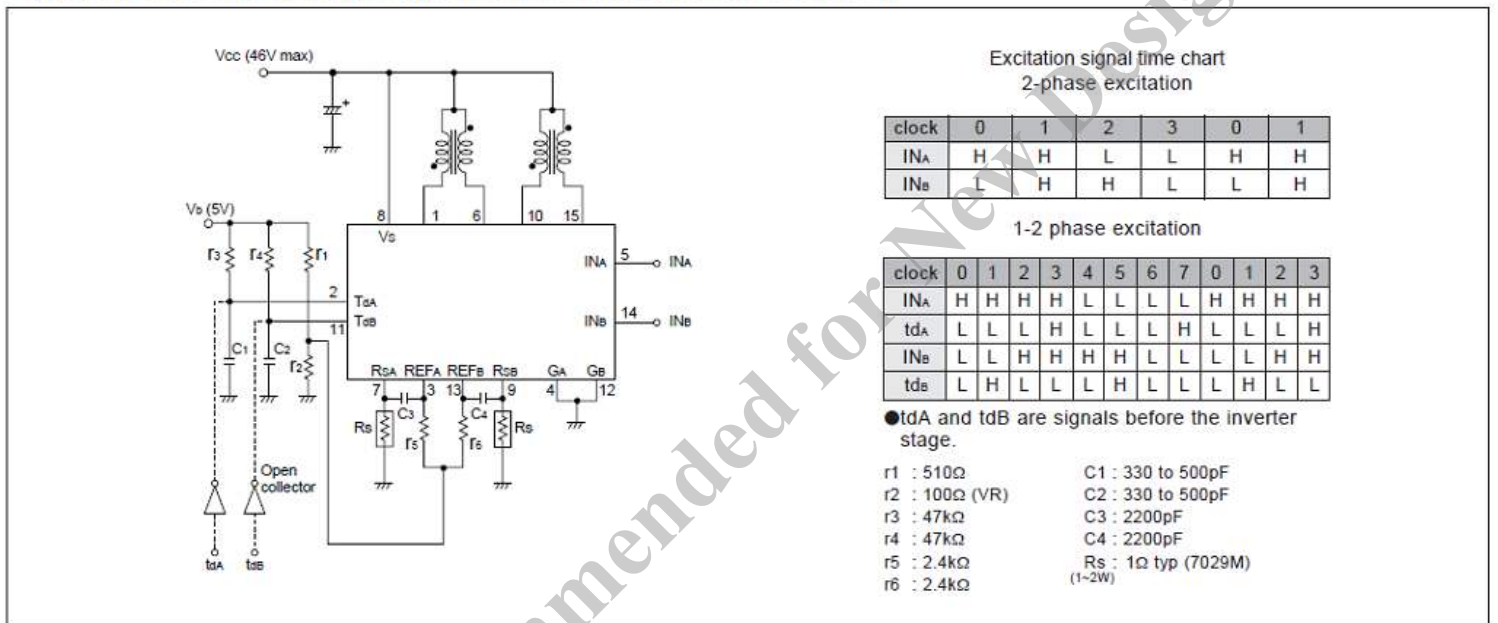

External Dimensions (ZIP15 with Fin [SLA15Pin] /ZIP15[SMA15Pin])

(Unit:mm)

