

DESCRIPTION

The LX8816 is a dual channel positive-voltage linear regulator. This dual regulator has one fixed output coupled with an adjustable output. Each channel features low-dropout and high accuracy.

The LX8816 provides designers with a flexible power management solution, minimal printed circuit board area and shorter design cycles.

Each channel can supply up to one amp independently with a regulator design optimized for system efficiency by consuming minimal ground current and directing quiescent current to the load.

The LX8816 features on-chip trimming of the internal voltage

enabling precise output voltages, typically $\pm 1\%$ of its specified value, while the BiPolar output transistor has a low dropout voltage even at full output current ($V_{DO} < 1.2V$ typ. @ 1A).

Thermal and Short Circuit Current Protection are integrated on-chip and operate independently for each regulator output.

The LX8816 regulator is stable with a low-value output capacitor, typically $2.2\mu F$ on the outputs, allowing designers flexibility in external component selection.

Microsemi's S-PAK package enables maximum power dissipation and ease of assembly using surface mount technology.

KEY FEATURES

- Two Independent Regulated Outputs
- Accurate Output Voltages
- Typical Dropout of 1.2V at 1A and 1.1V at 500mA
- Independent Thermal and Current Limit Protection
- Low Profile 5 Lead SMT Power Package
- Low Tolerance Load Regulation
- Wide DC Supply Voltage of 4.3V to 10V
- Loop Stability Independent of Output Capacitor Type

APPLICATIONS/BENEFITS

- 5V to 3.3V / ADJ Regulators
- Hard Disk Drives, CD-ROMs
- ADSL and Cable Modems
- Battery Charging Circuits
- Instrumentation
- PC Peripherals

IMPORTANT: For the most current data, consult MICROSEMI's website: <http://www.microsemi.com>

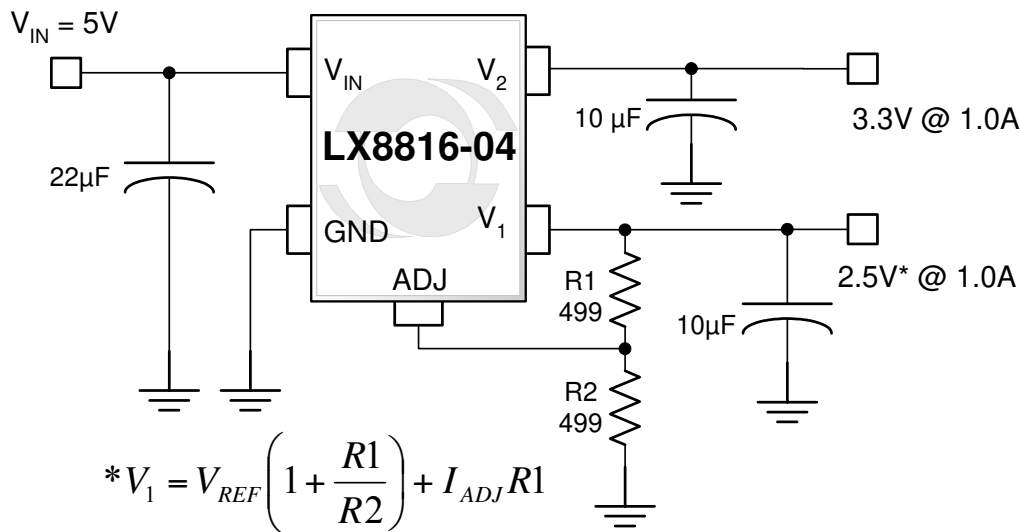
APPLICATION CIRCUITS

PACKAGE ORDER INFO

T_J (°C)	OUTPUT V_1 (PIN 4)	OUTPUT V_2 (PIN 5)	DF Plastic S-PAK 5-PIN RoHS Compliant Transition DC: 0515
0 to 125	Adj.	3.3V	LX8816-04CDF

Note: Available in Tape & Reel. Append the letters "TR" to the part number. (i.e. LX8816-04CDF-TR)

ABSOLUTE MAXIMUM RATINGS

Input Voltage (V_{BAT}).....	13.5V
Load Current (Internally Limited).....	1A
Power Dissipation.....	Internally Limited
Short-Circuit Protection.....	Indefinite
Operating Junction Temperature.....	150°C
Storage Temperature Range.....	-65°C to 150°C
Peak Package Solder Reflow Temperature (40 seconds maximum exposure).....	260°C (+0, -5)

Note: Exceeding these ratings could cause damage to the device. All voltages are with respect to Ground. Currents are positive into, negative out of specified terminal.

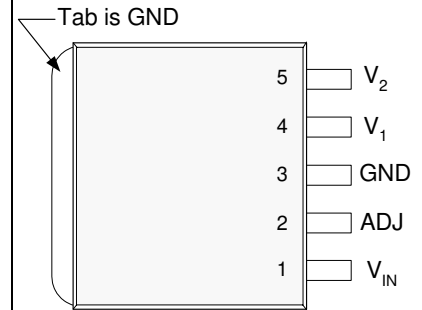
PACKAGE PIN OUT

DF PACKAGE
(Top View)

RoHS 100% Matte Tin Lead Finish

THERMAL DATA
DF Plastic S-Pak 5-Pin

THERMAL RESISTANCE-JUNCTION TO TAB, θ_{JT}	4.5°C/W
THERMAL RESISTANCE-JUNCTION TO AMBIENT, θ_{JA}	24.5°C/W

Junction Temperature Calculation: $T_J = T_A + (P_D \times \theta_{JA})$.

The θ_{JA} numbers are guidelines for the thermal performance of the device/pc-board system. All of the above assume no ambient airflow. θ_{JA} can vary from 25°C/W to > 40°C/W depending on mounting technique. (See Application Notes Section: Thermal considerations)

FUNCTIONAL PIN DESCRIPTION

PIN NAME	DESCRIPTION
V_{IN}	Positive unregulated supply input for the regulator. Bypass to GND with at least 2.2 μ F capacitance having low ESR for good transient response.
ADJ	Adjustable Input. The output voltage can be set by two external resistors with the following relationship: $V_1 = V_{REF} * (1 + R1 / R2) + I_{ADJ} * R1$ where R1 is the resistor connected between V_1 and ADJ, and R2 is the resistor connected between ADJ and GND.
GND	Common terminal for ground reference. The input and output bypass capacitors should be connected to this pin. In addition the tab on the S-Pak package and pin 3 are also used for heat sinking the device.
V_1	Adjustable regulator output (Regulator #1) It is recommended to bypass to GND with at least 2.2 μ F. Size your output capacitor to meet the transient loading requirement. If you have a very dynamic load, a lower ESR capacitor will improve the response to these load steps.
V_2	Fixed regulator output (Regulator #2). It is recommended to bypass to GND with at least 2.2 μ F. Size your output capacitor to meet the transient loading requirement. For dynamic loads, a lower ESR capacitor will improve the response to these load steps.

RECOMMENDED OPERATING CONDITIONS

Parameter	Symbol	LX8816-04			Units
		Min	Typ	Max	
Input Voltage	V_{IN}	4.5		10	V
Output Voltage (adjustable)	V_{OUT}			5.5	V
Load Current each output (with adequate heat sinking)		0		1000	mA
Input Capacitor (V_{IN} to GND)		2.2	20		μ F
Output Capacitor (V_{OUT} to GND)		1.0	10*		μ F

* Size your output capacitor to meet the transient loading requirement. If you have a very dynamic load, a lower ESR and larger value capacitor will improve the response to these load steps.

ELECTRICAL CHARACTERISTICS

Unless otherwise specified, the following specifications apply over the operating ambient temperature $0^{\circ}\text{C} \leq T_A \leq 125^{\circ}\text{C}$ except where otherwise noted and the following test conditions: $V_{IN} = 5\text{V}$, $I_{OUT} = 10\text{mA}$, $C_1 = 10\mu\text{F}$ (Tantalum), $C_2 = C_3 = 4.7\mu\text{F}$ (Tant.), & $T_J = T_A$ using low duty cycling methods.

Parameter	Symbol	Test Conditions	LX8816-04			Units
			Min	Typ	Max	
Adjustable Output (Output 1)						
Reference Voltage	V_{REF}	$5\text{mA} < I_1 < 1\text{A}$, $4.75\text{V} < V_{IN} < 10\text{V}$	1.225	1.25	1.273	V
Line Regulation	$\Delta V_1(V_{IN})$	$4.75\text{V} < V_{IN} < 5.5\text{V}$, $I_{OUT} = 5\text{mA}$		1.5	2.5	mV
Line Regulation	$\Delta V_1(V_{IN})$	$4.50\text{V} < V_{IN} < 10\text{V}$, $I_{OUT} = 5\text{mA}$		0.17	0.22	%V
Load Regulation	$\Delta V_{REF}(I_1)$	$5\text{mA} < I_1 < 1\text{A}$, $V_{IN} = 4.75\text{V}$		0.04	0.15	%V
Dropout Voltage	ΔV	$I_{LOAD} = 1\text{A}$, $\Delta V_1 = -2\%$		1.2	1.3	V
Current Limit	$I_{OUT(MAX)}$		1.0	1.4		A
Minimum Load Current	I_L	Note 1, The external resistor divider current can be included in this requirement.		2	3	mA
Adjust Pin Bias Current	I_{ADJ}	Bias current flows into part.		0.12	1	μ A
Fixed Output (Output 2)						
Output Voltage	V_2	$5\text{mA} < I_2 < 1\text{A}$, $4.75\text{V} < V_{IN} < 10\text{V}$	3.234	3.30	3.3825	V
Line Regulation	$\Delta V_2(V_{IN})$	$4.75\text{V} < V_{IN} < 5.5\text{V}$, $I_{OUT} = 5\text{mA}$		6	8	mV
Line Regulation	$\Delta V_2(V_{IN})$	$4.50\text{V} < V_{IN} < 10\text{V}$, $I_{OUT} = 5\text{mA}$		0.17	0.22	%V
Load Regulation	$\Delta V_2(I_2)$	$5\text{mA} < I_2 < 1\text{A}$, $V_{IN} = 4.75\text{V}$		2.6	6	mV
Dropout Voltage	ΔV	$I_{LOAD} = 1\text{A}$, $\Delta V_2 = -2\%$		1.2	1.3	V
Current Limit	$I_{OUT(MAX)}$		1.0	1.4		A
Minimum Load Current	I_L	Note 1			0	mA
Entire Regulator						
Quiescent Current	I_Q	$V_{IN} < 10\text{V}$, $I_1 = 5\text{mA}$, $I_2 = 5\text{mA}$		2.6	3.8	mA
Quiescent Current	I_Q	$V_{IN} \leq 10\text{V}$, $I_1 = 1\text{A}$, $I_2 = 1\text{A}$		3.5	6	mA
Ripple Rejection	PSRR	$f=120\text{Hz}$, $V_{IN} = 5\text{V}$	60	75		dB
RMS Output Noise (% of V_{OUT})	$V_{OUT(RMS)}$	$10\text{Hz} < f < 10\text{kHz}$		0.003		%V
Thermal Shutdown	T_{JSD}		135	140		$^{\circ}\text{C}$

Note 1: Minimum load current is defined as the amount of output current required to maintain regulation.

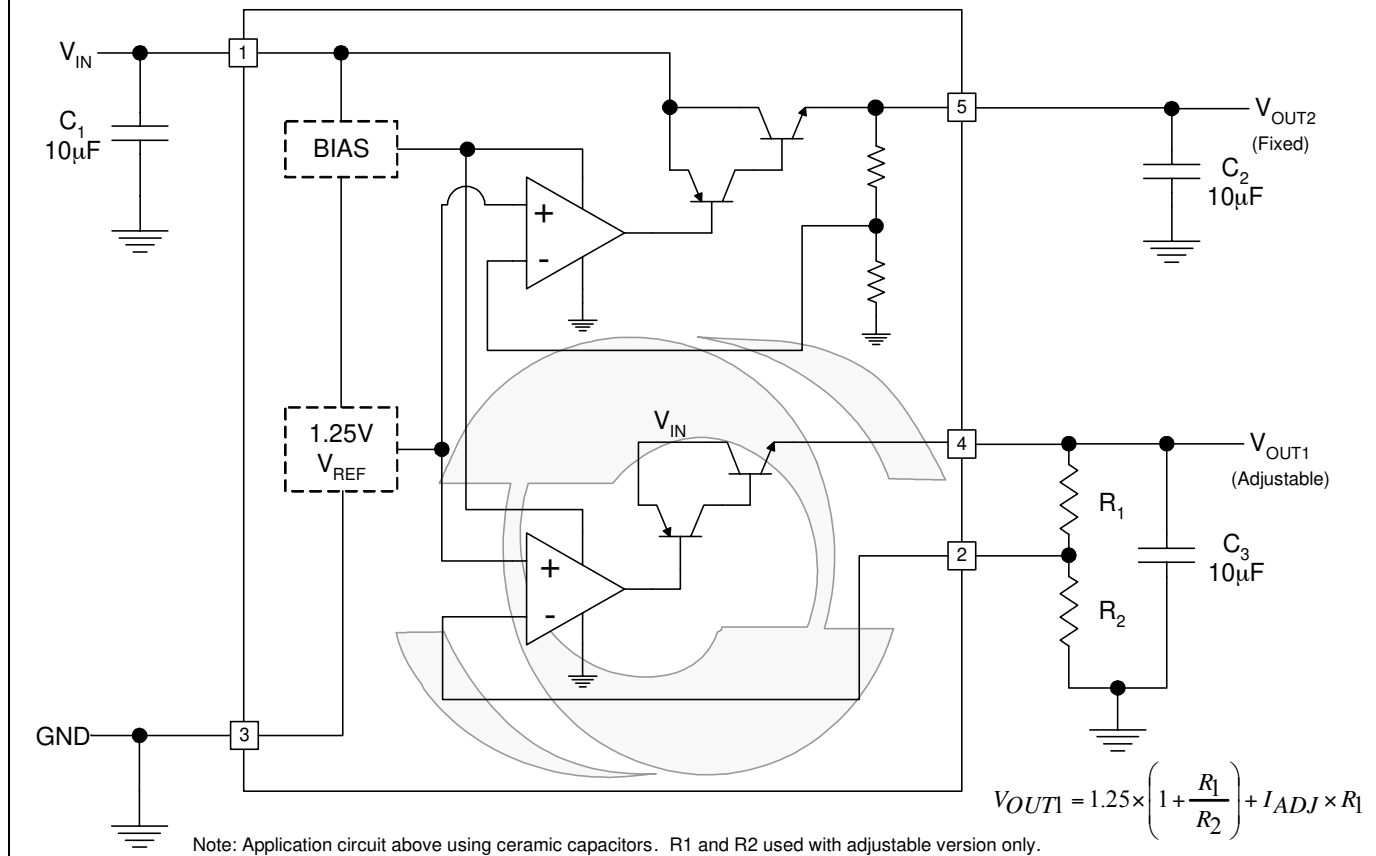
BLOCK DIAGRAM

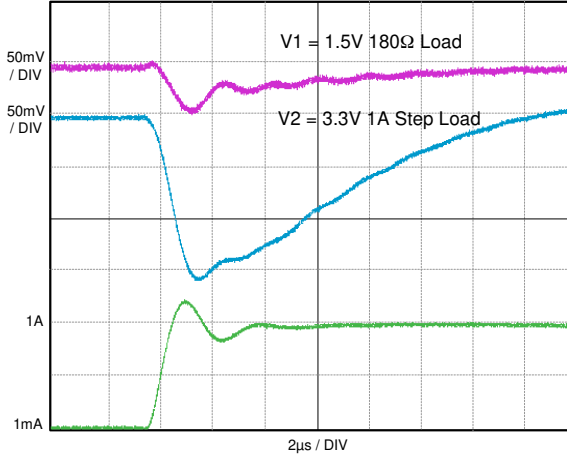
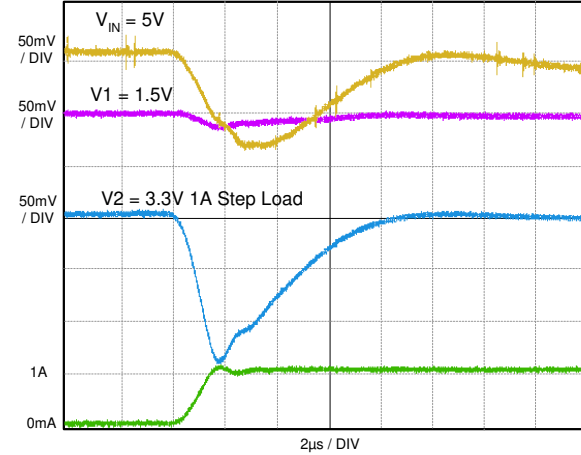
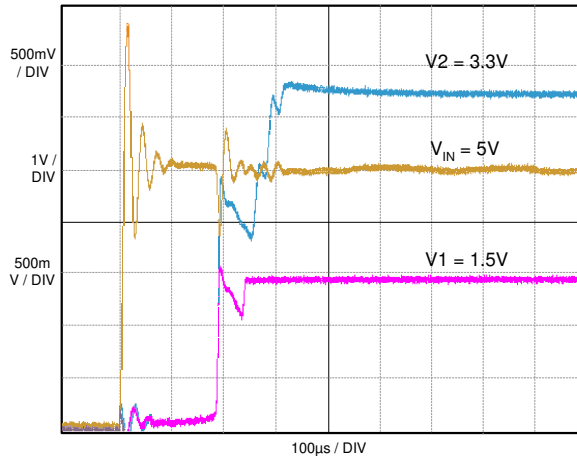
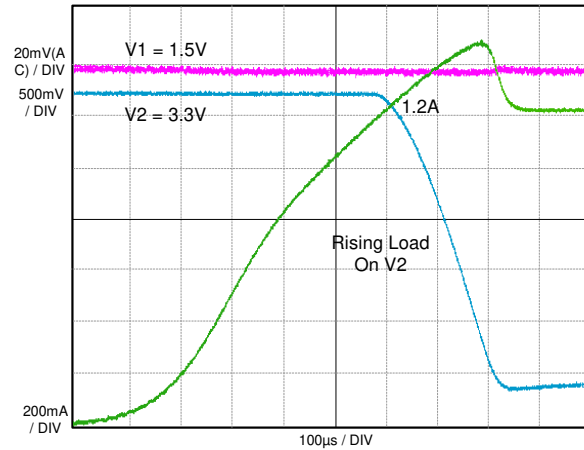
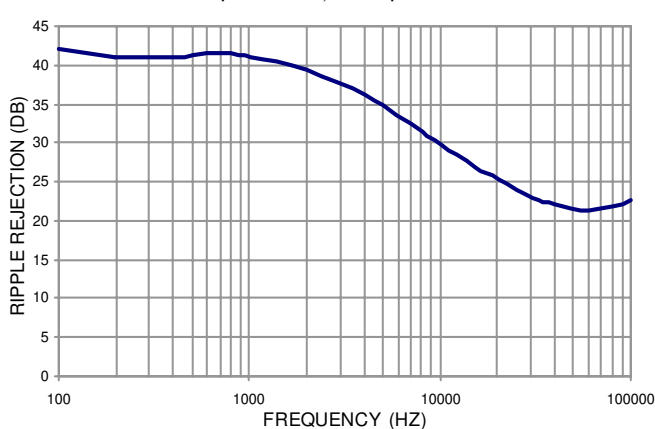
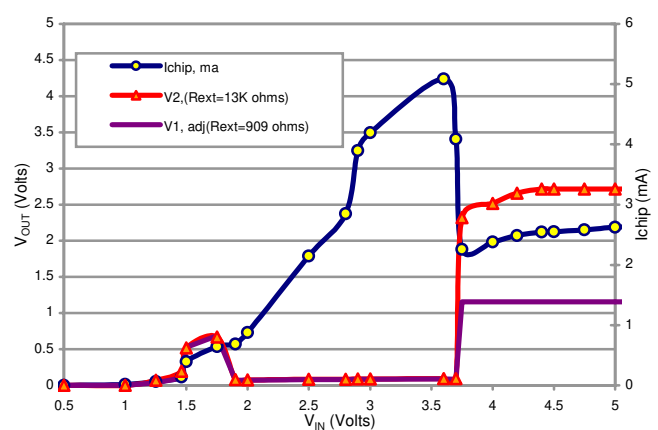
Figure 1 – Simplified Block Diagram

CHARACTERISTIC CURVES
LOAD TRANSIENT RESPONSE
 $V_{IN} = 20\mu\text{F Ceramic, ESR}=45\text{m}\Omega; V1, V2 = 10\mu\text{F Ceramic, ESR}=75\text{m}\Omega$

LOAD TRANSIENT RESPONSE
 $V_{IN} = 22\mu\text{F Tantalum, ESR}=232\text{m}\Omega; V1, V2 = 10\mu\text{F Tantalum, ESR}=198\text{m}\Omega$

TURN ON CHARACTERISTICS

CURRENT LIMIT RESPONSE

RIPPLE REJECTION VS. FREQUENCY
 $V_{IN} = 5\text{V, } C_{IN} = 22\mu\text{F, } C_{OUT1,2} = 10\mu\text{F, } V_2=3.3\text{V, } I_{OUT2}=1\text{A}$

 V_{OUT} AND I_{CHIP} VS. V_{IN} RAMP

APPLICATION INFORMATION
Description

The LX8816 is part of a family of Dual LDO (Low Drop-Out) linear regulators in Microsemi's S-PAK power package, which offer maximum power dissipation in a low profile surface mount technology. The family includes combination fixed and adjustable versions. Each channel can supply up to one amp independently with a regulator design optimized for system efficiency by consuming minimal ground current and directing quiescent current to the load.

Input Capacitor

To improve load transient response and noise rejection a input bypass capacitor is of at least 2.2uF is required. Generally we recommend a 20uF ceramic or tantalum or 22uF electrolytic capacitor.

Output Capacitor

The regulator requires output capacitors connected between V_1 , V_2 and GND to stabilize the internal control loop. Many types of capacitors are available, with different capacitance values tolerances, temperature coefficients and equivalent series resistance. We recommend a minimum of 4.7uF. To ensure good transient response from the power supply system under rapidly changing current load conditions, designers generally use additional output capacitors connected in parallel. Such an arrangement serves to minimize the effects of the parasitic resistance (ESR) and inductance (ESL) that are present in all capacitors. The regulator has been tested stable with capacitor ESR's in the range of 0.05 to 2 ohms. We have found it best to use the same type of capacitor for both input and output bypass.

Adjustable Output Voltage

The LX8816 develops a 1.25V reference voltage between the adjust terminal and GND (See Figure 2). By placing a resistor, R2, between these two terminals, a constant current is caused to flow through R1 and down through R2 to set the overall output voltage. Because I_{ADJ} is very small and constant when compared with the current through R2, it represents a small error and can usually be ignored.

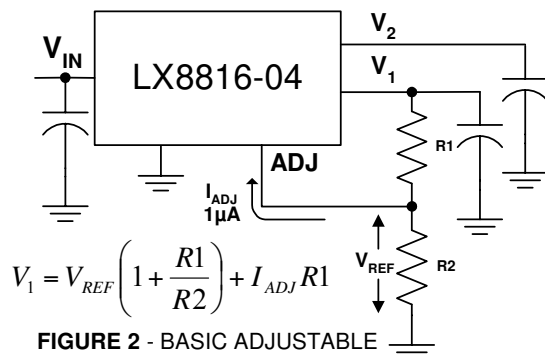

FIGURE 2 - BASIC ADJUSTABLE REGULATOR

Minimum Load Requirement

The LX8816 has a minimum load is requirement for proper output regulation. This minimum current is specified at 0mA for the fixed output and 2ma for the adjustable output regulators.

Temperature Protection

The thermal protection shuts the LX8816 down when the junction temperature exceeds 140°C. Each output has independent thermal shutdown capability. Exposure to absolute maximum rated conditions for extended periods may affect device reliability, see Thermal Considerations below.

Current Limit Protection

The LX8816 includes over current protection, when the output load current exceeds typically 1.4A the circuit forces the regulator decrease in output.

Thermal Considerations

Thermal shutdown protects the integrated circuit from thermal overload caused from a rise in junction temperature during power dissipation. This means of protection is intended for fault protection only and not as a means of current or power limiting during normal application usage. Proper thermal evaluation should be done to ensure that the junction temperature dose not exceed it's maximum rating. Operating at the maximum T_J of 150°C can impact reliability. Due to variation in individual device electrical characteristics and thermal resistance, the built in thermal overload protection may be activated at power levels slightly above or below the rated dissipation. Also peak output power should be considered for each individual output.

Power dissipation for regulator can be calculated using the following equation:

$$P_D = (V_{IN(MAX)} - V_1) * I_1 + (V_{IN(MAX)} - V_2) * I_2$$

(Note: power dissipation resulting from quiescent (ground) current is negligible)

For the S-PAK package, thermal resistance, $\theta_{TAB-AMB}$ is 25-45°C/W depending on mounting technique when mounted on a FR4 copper clad PCB. Junction temperature of the integrated circuit can be calculated using:

$$T_{JUNCTION} = T_{JUNCTION-TAB RISE} + T_{TAB-AMB RISE} + T_{AMB}$$

$$T_{TAB} = P_{D MAX} * \theta_{JT} ; T_{TAB-AMB} = (P_{D REG1} + P_{D REG2}) * \theta_{PCB}$$

An example: Given conditions: $T_A = 50^\circ C$, $V_{IN} = 5.0V$, $V_1 = 2.5V$, $I_1 = 210mA$, $V_2 = 3.3V$ $I_2 = 1A$.

Calculated values:

$$T_{J-TAB REG1} = (5V - 2.5V) * (210mA) * 4.5^\circ C/W = (0.525) * 4.5^\circ C/W = 2.4^\circ C$$

$$T_{J-TAB REG2} = (5V - 3.3V) * (1.0A) * 4.5^\circ C/W = (1.7) * 4.5^\circ C/W = 7.7^\circ C$$

$$T_{TAB-AMB RISE} = (0.525W + 1.7W) * 30^\circ C/W = 66.8^\circ C$$

$$T_{JUNCTION} = 10.1^\circ C + 66.8^\circ C + 50^\circ C = 126.9^\circ C$$

It is important to note that although each output of the regulator will produce up to 1A in current, the individual or total power dissipation may limit the useful total current draw. The junction temperature should be calculated for each individual output as well as the combined outputs to insure the maximum junction temperature in not exceeded.

APPLICATION INFORMATION
Layout Consideration

The layout must be done with low impedance paths for V_{IN} , V_1 , V_2 and Ground by using sufficiently wide traces to avoid voltage drops and noise pick up. The output capacitors must be placed as close as possible to the voltage regulator output pins. To allow the same voltage reference for all circuits, use a star configuration from the output capacitors to the different loads. The input capacitor should be connected between V_{IN} and ground with short leads. Although it may not be immediately obvious, best load regulation for the adjustable output is obtained when the top of the resistor divider, ($R1$), is connected *as close as possible* to the case of the regulator, *not to the load*.

Heatsink Consideration

The PCB copper can be used as a heatsink for the surface mounted S-Pak. Using the minimum size as shown in the recommended pad layout limits the usable power to about 1W for ambient temperature of 50°C. Since most applications require greater than 2W there is the need to provide additional heat sinking. This can be accomplished by using additional copper area both on the PCB surface as shown in the possible heat sink layout below, or to an embedded ground plane. Since the die pad (copper tab) is in electrical contact with ground, the designer can use thermal vias on the surface of the PCB taking advantage of the heat-spreading (Cu) layer of an internal ground plane.

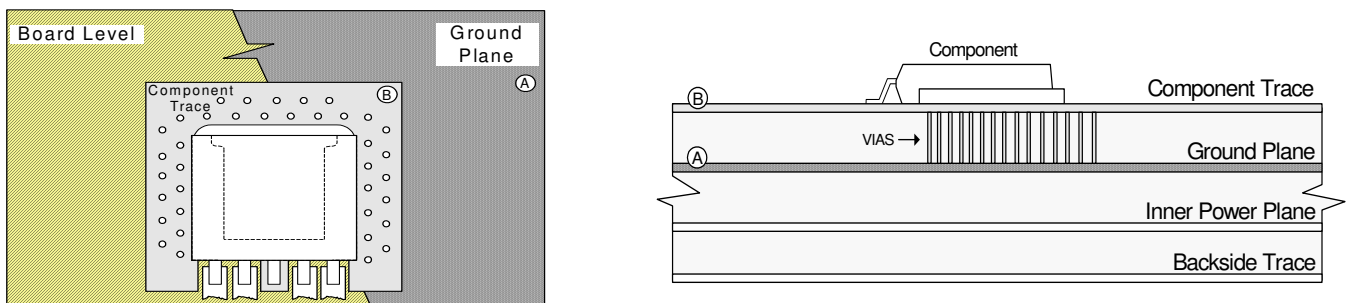
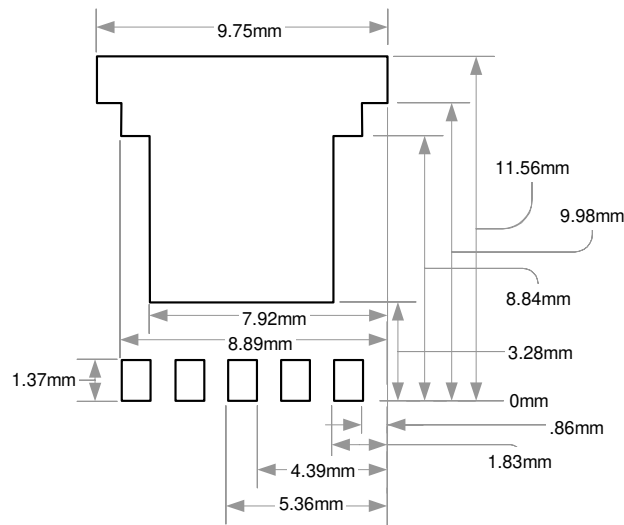
HEAT SINK LAYOUT

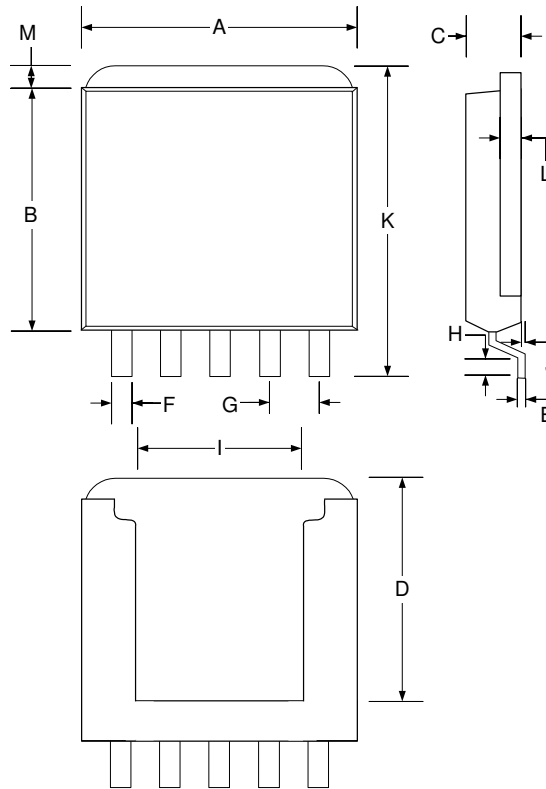
Figure 3 - Heatsink
RECOMMENDED MINIMUM PCB FOOTPRINT

PACKAGE DIMENSIONS
DF 5-Pin Plastic S-Pak

Dim	MILLIMETERS		INCHES	
	MIN	MAX	MIN	MAX
A	9.27	9.52	0.365	0.375
B	7.87	8.13	0.310	0.320
C	1.78	2.03	0.070	0.080
D	8.03 BSC		0.316 BSC	
E	0.25 BSC		0.010 BSC	
F	0.63	0.79	0.025	0.031
G	1.70 BSC		0.067 BSC	
H	0.79	1.04	0.031	0.041
I	6.50 BSC		0.256 BSC	
J	0.03	0.13	0.001	0.005
K	10.41	10.67	0.410	0.420
L	0.25 BSC		0.01 BSC	
M	0.76	1.27	0.03	0.05

Note: Dimensions do not include mold flash or protrusions; these shall not exceed 0.155mm(.006") on any side. Lead dimension shall not include solder coverage.



LX8816

Dual Channel 1A Low Dropout Regulator

PRODUCTION DATA SHEET

NOTES

PRODUCTION DATA – Information contained in this document is proprietary to Microsemi and is current as of publication date. This document may not be modified in any way without the express written consent of Microsemi. Product processing does not necessarily include testing of all parameters. Microsemi reserves the right to change the configuration and performance of the product and to discontinue product at any time.