

*Cheval*

# PF-19 Series

**NEW**

**Aluminum Design**



The PF-19 Series of rack mounted 19" Enclosures is very versatile and user friendly. Designed for both professional users and home hobbyists alike, our latest version continues the trend of reducing hardware and maximizing user convenience. The high grade aluminum body features perforated, removable top and bottom panels providing ample ventilation and easy access to work inside. The 3.00 mm thick Aluminum outer front panel covers the easily worked inner front panel to give your project a professional look.

Our customized extruded aluminum component mounting bars are slotted to allow for convenient PCB and component installation. PF-19 is provided with self adhesive rubber feet if rack mounting is not required.

## Standards and Materials

- Heights from 1U to 6U
- Depths of 245mm, 335mm and 425mm
- Dimensions conform to IEC-60297-3
- Premium grade (AL 5052) aluminum.
- Designed and manufactured under ISO 9001:2008 and ISO 14001:2004
- All materials RoHS compliant.



International Inquiries: Email: [commce@chevalgrp.com](mailto:commce@chevalgrp.com)  
Thailand Inquiries: Email: [domestic\\_sales@chevalgrp.com](mailto:domestic_sales@chevalgrp.com)

Tel: +66 2315 1504-5  
Tel: +66 2744 1632

Fax: +66 2315 1506  
Fax: +66 2399 1783



Cheval Electronic Enclosure Co., Ltd

[www.chevalgrp.com](http://www.chevalgrp.com)

# Key Features

- Light weight and strong
- Very durable all aluminum (AL 5052) construction
- Easy to assemble
- Extensive top/bottom and side/side ventilation
- Inner front panel for component mounting allows outer front panel to remain “clean” appearance
- Two pieces of extruded aluminum component mounting bars for components fixing are included in the basic kit. Additional bars may be ordered as needed.
- Optional mounting plates for PCB and heavy components such as transformers
- Optional solid side covers for air flow control or decorative look in non 19” rack mounted applications
- 19” rack mounted or free standing
- Flat pack for efficient storage and shipping

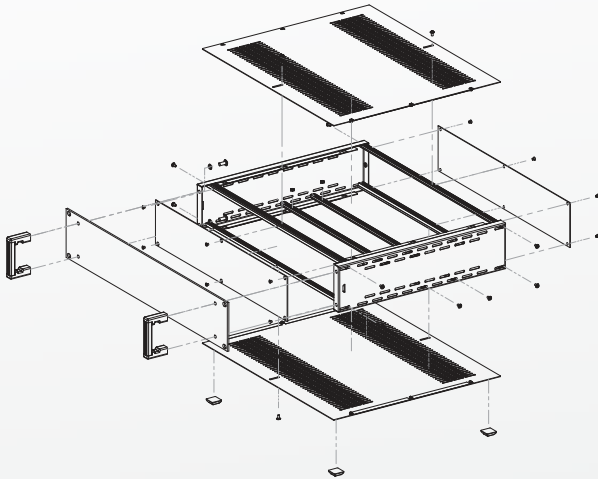

▶ “Open Frame” design maximizes user convenience for component assembly

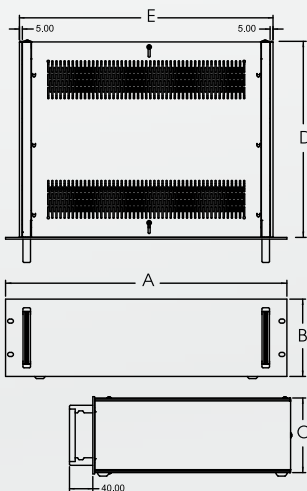

Part Number	Front Panel Size (mm.) (A x B)	Cabinet Size (mm.) (C x D x E)	Unit Gross Weight (kg.)	Carton Dimension H x W x D (mm.)
PF19AL1UD1	482.60 x 43.70 x 3.00	38.70 x 245.00 x 425.00	1.77	70 x 281.70 x 498.40
PF19AL1UD2	482.60 x 43.70 x 3.00	38.70 x 335.00 x 425.00	2.14	70 x 371.70 x 498.40
PF19AL1UD3	482.60 x 43.70 x 3.00	38.70 x 425.00 x 425.00	2.52	70 x 461.70 x 498.40
PF19AL2UD1	482.60 x 88.10 x 3.00	83.10 x 245.00 x 425.00	2.16	70 x 281.70 x 498.40
PF19AL2UD2	482.60 x 88.10 x 3.00	83.10 x 335.00 x 425.00	2.57	70 x 371.70 x 498.40
PF19AL2UD3	482.60 x 88.10 x 3.00	83.10 x 425.00 x 425.00	2.95	70 x 461.70 x 498.40
PF19AL3UD2	482.60 x 132.60 x 3.00	127.60 x 335.00 x 425.00	2.94	70 x 371.70 x 498.40
PF19AL3UD3	482.60 x 132.60 x 3.00	127.60 x 425.00 x 425.00	3.37	70 x 461.70 x 498.40
PF19AL4UD2	482.60 x 177.00 x 3.00	172.00 x 335.00 x 425.00	3.36	70 x 371.70 x 498.40
PF19AL4UD3	482.60 x 177.00 x 3.00	172.00 x 425.00 x 425.00	3.79	70 x 461.70 x 498.40
PF19AL5UD2	482.60 x 221.50 x 3.00	216.50 x 335.00 x 425.00	3.78	70 x 371.70 x 498.40
PF19AL5UD3	482.60 x 221.50 x 3.00	216.50 x 425.00 x 425.00	4.21	70 x 461.70 x 498.40
PF19AL6UD3	482.60 x 265.90 x 3.00	261.00 x 425.00 x 425.00	4.42	70 x 461.70 x 498.40
PF19AL6UD4	482.60 x 265.90 x 3.00	261.00 x 465.00 x 425.00	4.63	70 x 502.00 x 498.40