

8V Input, Low Quiescent Current Linear Regulator

UM1550S SOT23-3
UM1550Y SOT89-3
UM1550B SOT89-3
UM1550DA DFN6 2.0×2.0
UM1550DB DFN4 1.0×1.0
UM1560S SOT23-5
UM1560P SOT343
UM1560DA DFN6 2.0×2.0
UM1560DB DFN4 1.0×1.0

General Description

The UM1550/1560 series is a set of high input voltage low quiescent current regulator implemented in CMOS technology. They can deliver 300mA output current and allow an input voltage as high as 8V. They are available with several fixed output voltages ranging from 1.2V to 5.0V. CMOS technology ensures low voltage drop and low quiescent current.

The UM1550 is available in SOT23-3, SOT89-3, DFN6 2.0×2.0 and DFN4 1.0×1.0 packages. The UM1560 is available in SOT23-5, SOT343, DFN6 2.0×2.0 and DFN4 1.0×1.0 packages.

Applications

- Communication Equipments
- Audio/Video Equipments
- Portable Games
- Portable AV Equipments
- Battery-Powered Equipments

Features

- Input Voltage Range: 1.8V to 8V
- 300mA Guaranteed Output Current
- Low Dropout Voltage: 250mV (Typical) at 200mA
- Low Quiescent Current: 2.5 μ A@V_{IN}=8V (Typical)
- Low Noise: 115 μ V_{RMS} (10Hz to 100kHz)
- Available Fixed Output Voltage from 1.2V to 5.0V with 0.1V Step
- With Shutdown Control (UM1560)
- Output Current Limit
- Low Profile SOT23-3, SOT23-5, SOT89-3, SOT343, DFN6 2.0×2.0 and DFN4 1.0×1.0 Packages

Typical Application Circuits

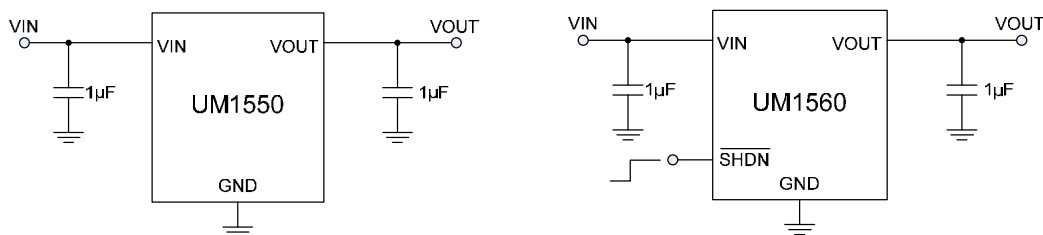

Pin Configurations

Top View

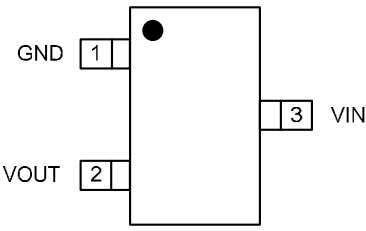
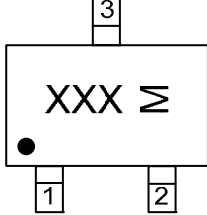
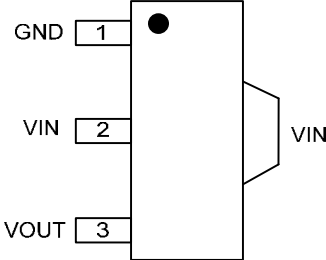
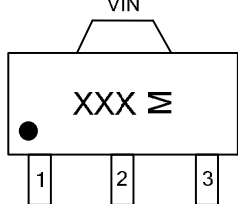
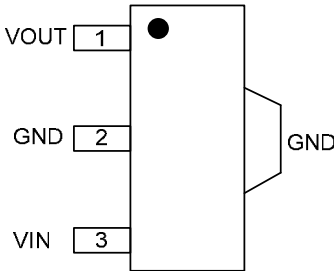
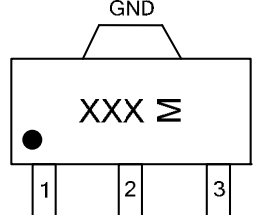
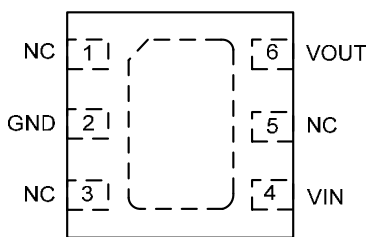
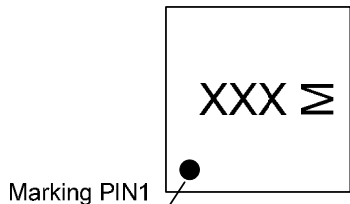
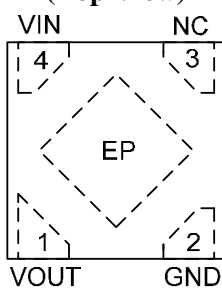
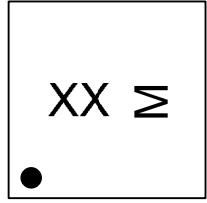
 <p style="text-align: center;">UM1550S</p>	 <p style="text-align: center;">M: Month Code UM1550S SOT23-3</p>
 <p style="text-align: center;">UM1550Y</p>	 <p style="text-align: center;">M: Month Code UM1550Y SOT89-3</p>
 <p style="text-align: center;">UM1550B</p>	 <p style="text-align: center;">M: Month Code UM1550B SOT89-3</p>
<p style="text-align: center;">(Top View)</p>  <p style="text-align: center;">UM1550DA</p>	 <p style="text-align: center;">M: Month Code UM1550DA DFN6 2.0x2.0</p>
<p style="text-align: center;">(Top View)</p>  <p style="text-align: center;">UM1550DB</p>	 <p style="text-align: center;">M: Month Code UM1550DB DFN4 1.0x1.0</p>

Pin Configurations

Top View

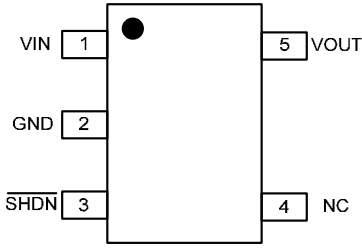
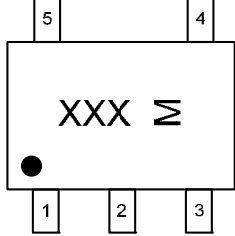
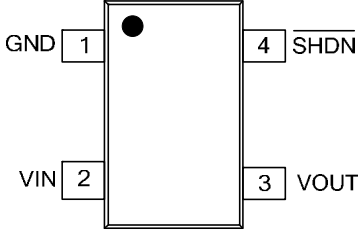
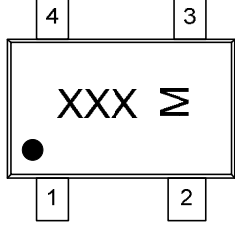
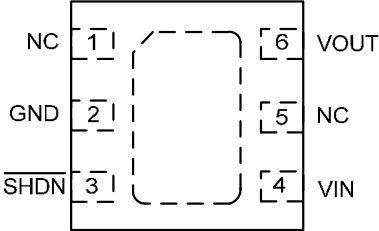
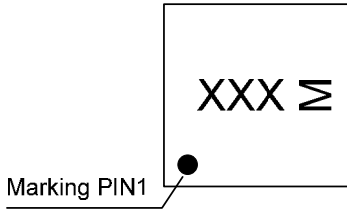
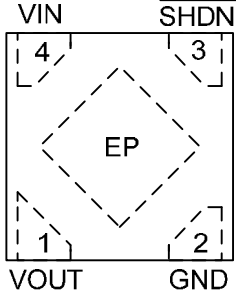
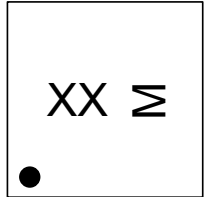
 <p style="text-align: center;">UM1560S</p>	 <p style="text-align: center;">M: Month Code UM1560S SOT23-5</p>
 <p style="text-align: center;">UM1560P</p>	 <p style="text-align: center;">M: Month Code UM1560P SOT343</p>
<p style="text-align: center;">(Top View)</p>  <p style="text-align: center;">UM1560DA</p>	 <p style="text-align: center;">M: Month Code UM1560DA DFN6 2.0x2.0</p>
<p style="text-align: center;">(Top View)</p>  <p style="text-align: center;">UM1560DB</p>	 <p style="text-align: center;">M: Month Code UM1560DB DFN4 1.0x1.0</p>

Pin Description

Pin Name	Pin Function
SHDN	Shutdown Control Input: High=Activate LDO, Low=Shutdown LDO
GND	Ground
VIN	Supply Input
VOUT	Voltage Regulated Output
NC	Not Connected
EP	Exposed Pad. Not connected.

Naming Information

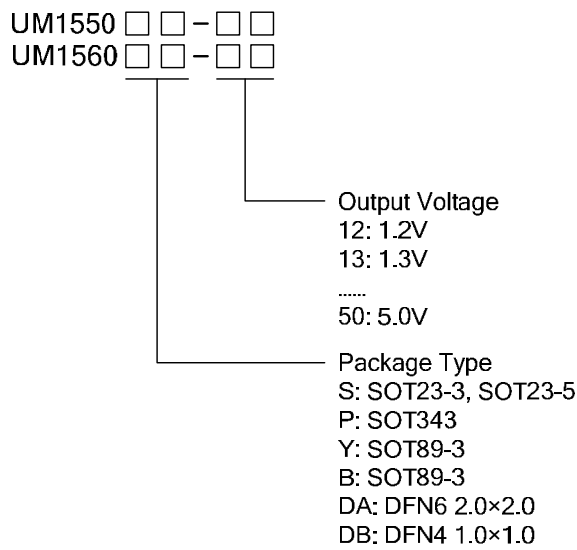

Absolute Maximum Ratings (Note 1)

Symbol	Parameter	Value	Unit	
V _{IN}	Supply Voltage on VIN Pin	-0.3 to +10	V	
V _{OUT}	Voltage on VOUT Pin	-0.3 to +10	V	
T _J	Operating Junction Temperature (Note 2, 3)	-40 to +125	°C	
T _{STG}	Storage Temperature Range	-65 to +150	°C	
T _L	Lead Temperature for Soldering 10 Seconds	+260	°C	
P _D (Note 4)	Power Dissipation@25°C	SOT23-3	0.40	W
		SOT89-3	1.0	
		SOT23-5	0.43	
		SOT343	0.40	
		DFN6 2.0×2.0	0.9	
		DFN4 1.0×1.0	0.4	
θ _{JA}	Package Thermal Resistance	SOT23-3	250	°C/W
		SOT89-5	100	
		SOT23-5	230	
		SOT343	250	
		DFN6 2.0×2.0	110	
		DFN4 1.0×1.0	250	

Note 1: Absolute Maximum Ratings are those values beyond which the life of a device may be impaired.

Note 2: The UM1550/1560 is tested and specified under pulse load conditions such that $T_J \approx T_A$. Specifications over the -40°C to 125°C operating junction temperature range are assured by design, characterization and correlation with statistical process controls.

Note 3: This IC includes over temperature protection that is intended to protect the device during momentary overload conditions. Junction temperature will exceed 125°C when over temperature protection is active. Continuous operation above the specified maximum operating junction temperature may impair device reliability.

Note 4: The maximum allowable power dissipation of any T_A (ambient temperature) is $P_{D\text{MAX}} = (T_{J\text{MAX}} - T_A) / \theta_{JA}$. Exceeding the maximum allowable power dissipation will result in excessive die temperature and the regulator will go into thermal shutdown.

Electrical Characteristics
 $V_{IN} = V_{OUT} + 1V$, $C_{IN} = C_{OUT} = 1\mu F$, $T_A = 25^\circ C$.

Symbol	Parameter	Test Conditions	Min	Typ	Max	Unit
V_{IN}	Input Voltage Range		1.8		8	V
V_{OUT}	Output Voltage Range		1.2		5.0	V
I_Q	Operating Quiescent Current	$V_{IN} = 8V$, $I_{OUT} = 0mA$		2.5	3.5	μA
	Shut Down Quiescent Current	$V_{IN} = 8V$, $\overline{SHDN} = GND$			1	μA
$I_{\overline{SHDN}}$	\overline{SHDN} Input Current	$\overline{SHDN} = V_{IN}$ or GND			1	μA
I_{OUT}	Output Current		300			mA
	Output Voltage Accuracy	$1mA \leq I_{OUT} \leq 250mA$	-2.5		+2.5	%
ΔV_{DO}	Dropout Voltage	$I_{OUT} = 200mA$		250	330	mV
I_{LIMIT}	Output Current Limit	$R_L = 1\Omega$	350	450	550	mA
t	Startup Time Response	$V_{OUT} = 3.3V$, $R_L = 68\Omega$, $C_{OUT} = 1\mu F$		80		μs
V_{IL}	\overline{SHDN} Input Low Voltage	$V_{IN} = 1.8V$ to 8V			0.4	V
V_{IH}	\overline{SHDN} Input High Voltage	$V_{IN} = 1.8V$ to 8V	1.2			V
	Output Voltage TC	$-40^\circ C$ to $+125^\circ C$		60		ppm/ $^\circ C$
	Line Regulation	$V_{OUT} + 0.3V \leq V_{IN} \leq 8.0V$ or $V_{IN} > 1.8V$ $I_{OUT} = 10mA$			0.3	%/V
	Load Regulation	$V_{IN} = V_{OUT} + 1V$ or $V_{IN} > 1.8V$ $1mA \leq I_{OUT} \leq 250mA$			0.6	%
	Output Voltage Noise	$V_{OUT} = 3.0V$, $f = 10Hz$ to $100kHz$, $C_{IN} = 1\mu F$, $I_{OUT} = 100mA$		115		μV_{RMS}
PSRR	Power Supply Ripple Rejection	$V_{IN} = V_{OUT} + 1V$ $I_{OUT} = 100mA$	$f = 100Hz$		56	dB
			$f = 1kHz$		42	
	ESD Rating	Human Body Mode	2			kV

Typical Operating Characteristics (Shown for 3.0V Output Option)

($C_{IN}=1.0\mu F$, $C_{OUT}=1.0\mu F$, $T_A=25^\circ C$, unless otherwise specified.)

Quiescent Current vs. Input Voltage
 $I_{OUT}=0mA$

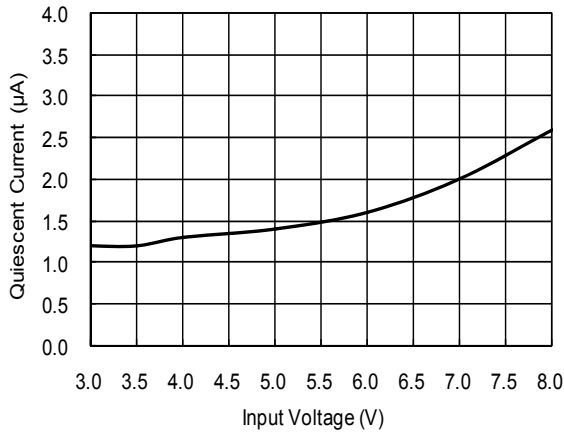

Quiescent Current vs. Temperature
 $V_{IN}=8V$, $I_{OUT}=0mA$

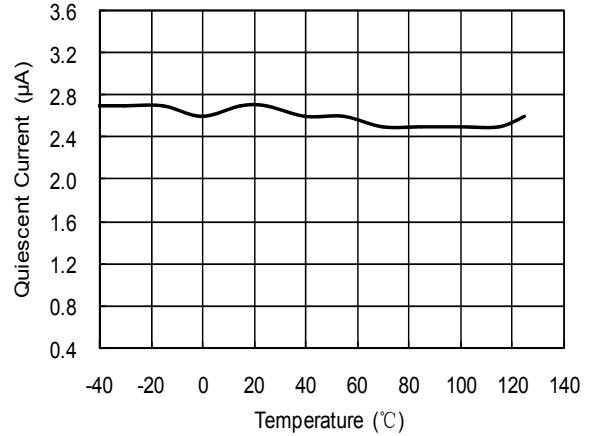

Output Voltage vs. Input Voltage
UM1560S-30

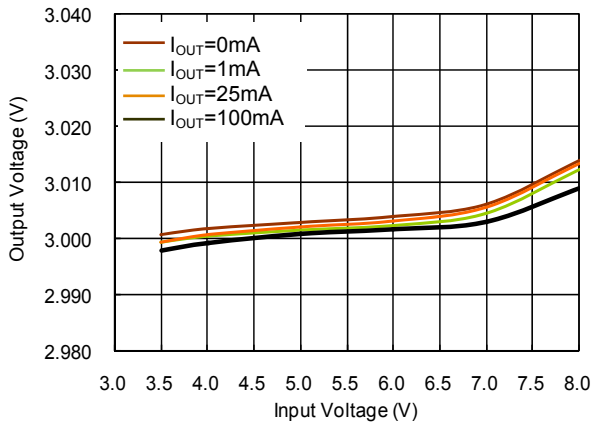

Output Voltage vs. Output Current
UM1560S-30, $V_{IN}=4.0V$

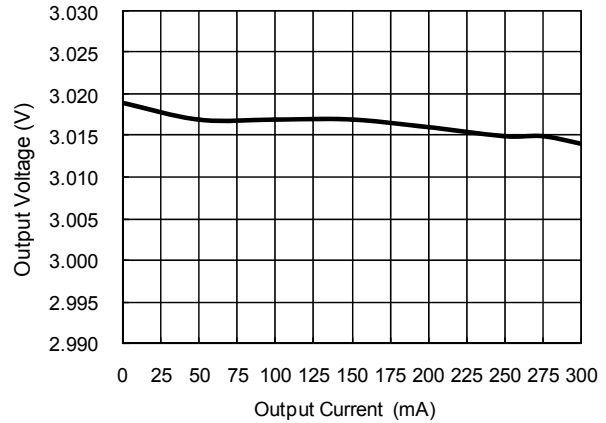

Output Voltage vs. Temperature
UM1560S-30, $V_{IN}=4V$, $I_{OUT}=3mA$

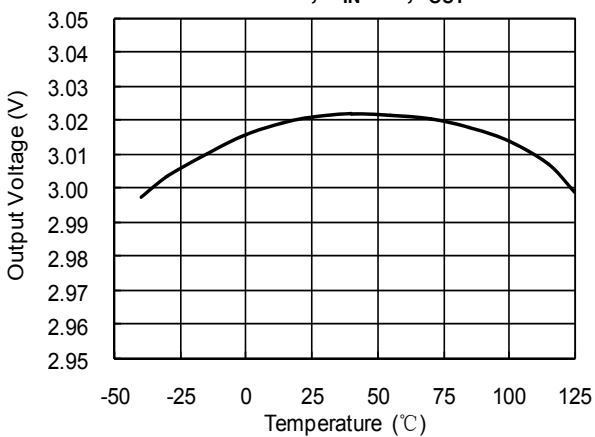

Dropout Voltage vs. Output Current

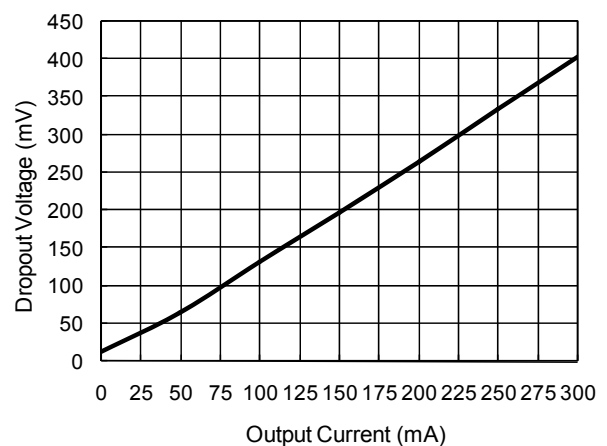

Typical Operating Characteristics (Continued) (Shown for 3.0V Output Option) (C_{IN}=1.0μF, C_{OUT}=1.0μF, T_A=25°C, unless otherwise specified.)

Enable Threshold Voltage vs. Input Voltage

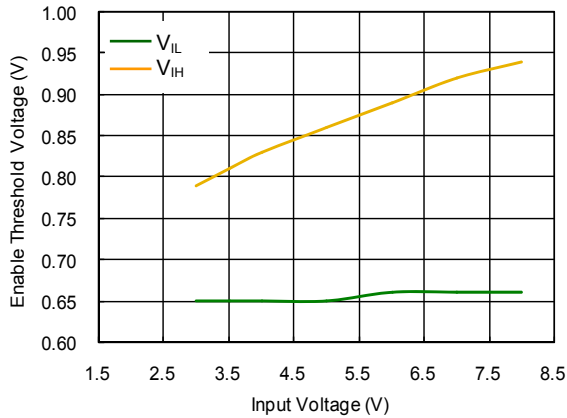

PSRR vs. Frequency UM1560S-30

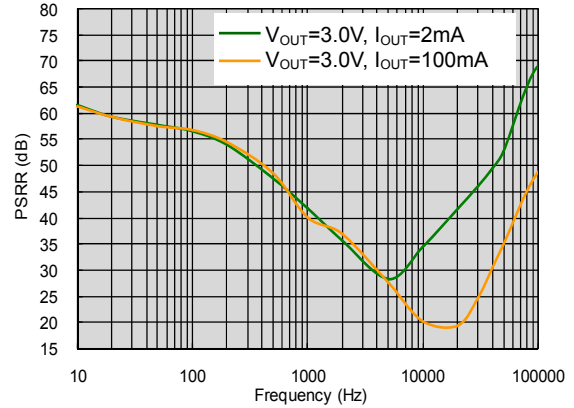

Noise

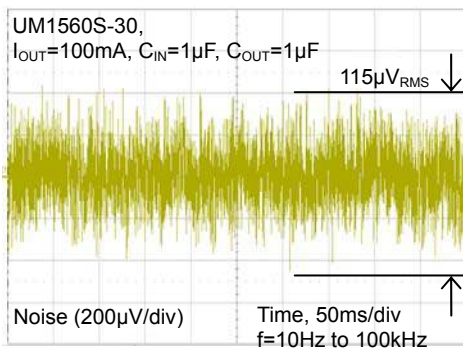

Load Transient Response

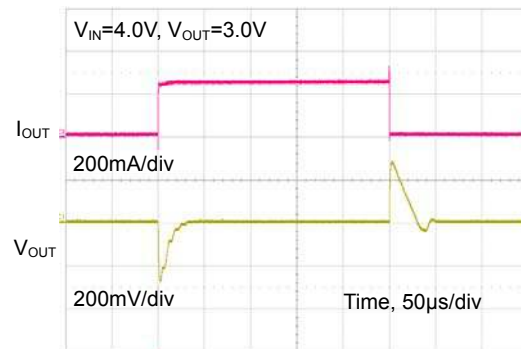

Line Transient Response

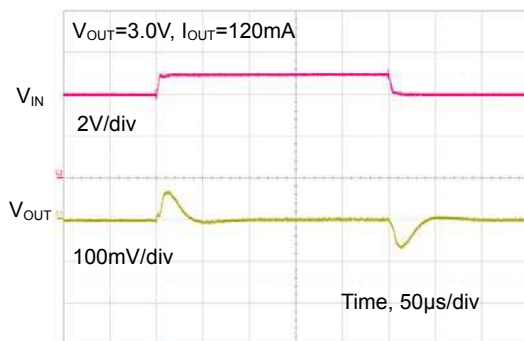

Start Up Response

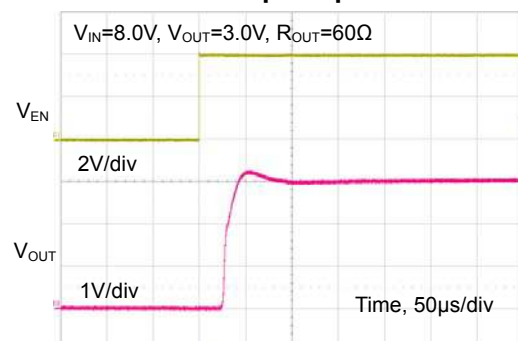

Package Information

UM1550S: SOT23-3

Outline Drawing

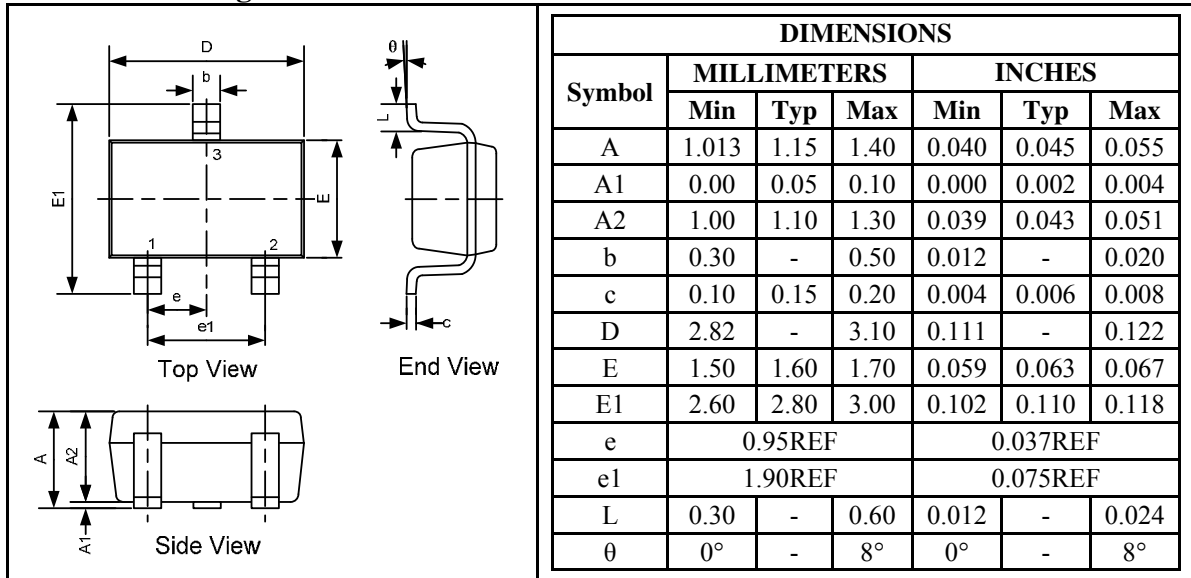

Land Pattern

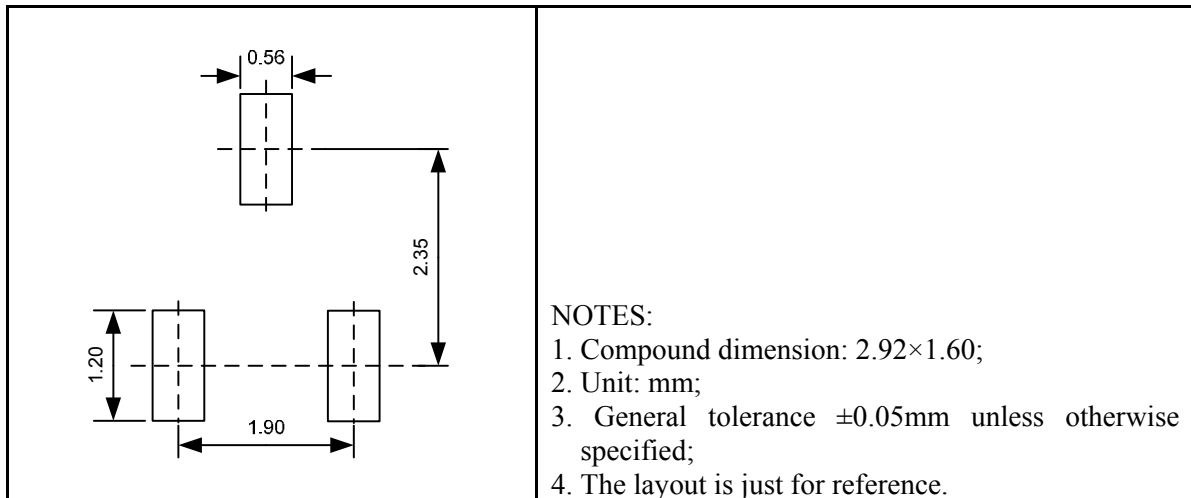

Tape and Reel Orientation

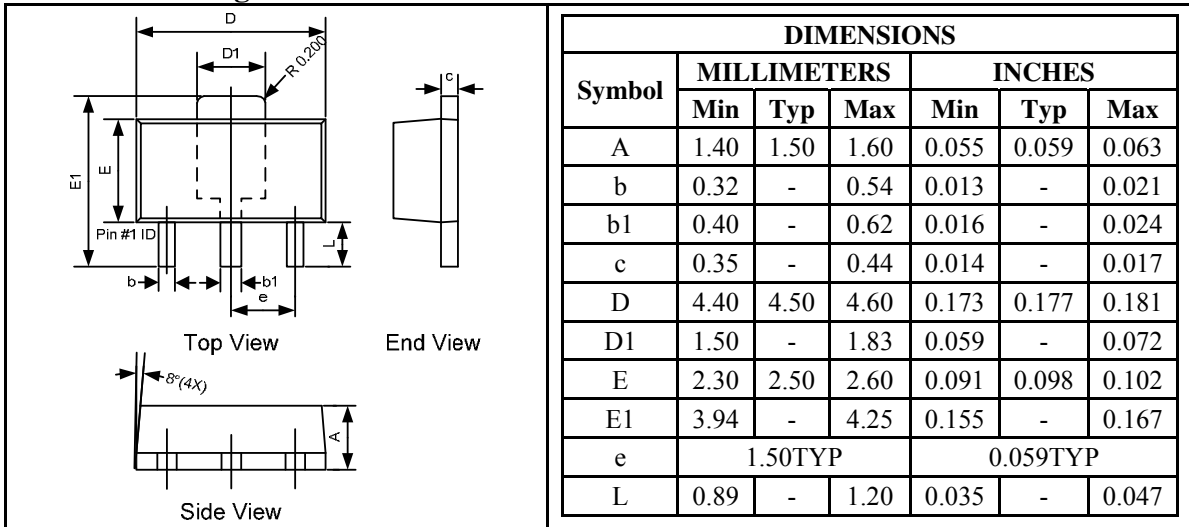
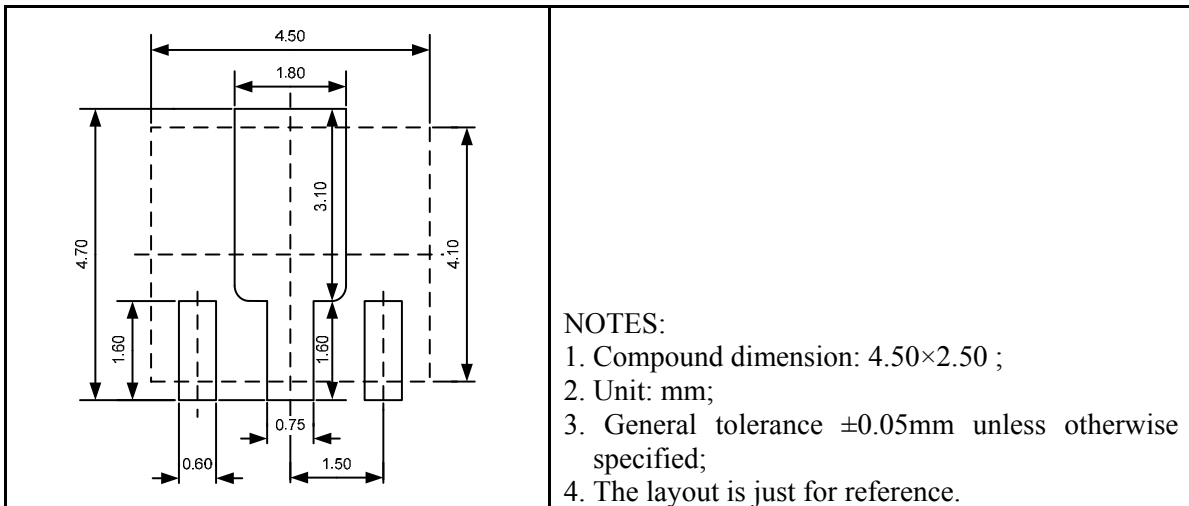

UM1550Y, UM1550B: SOT89-3
Outline Drawing

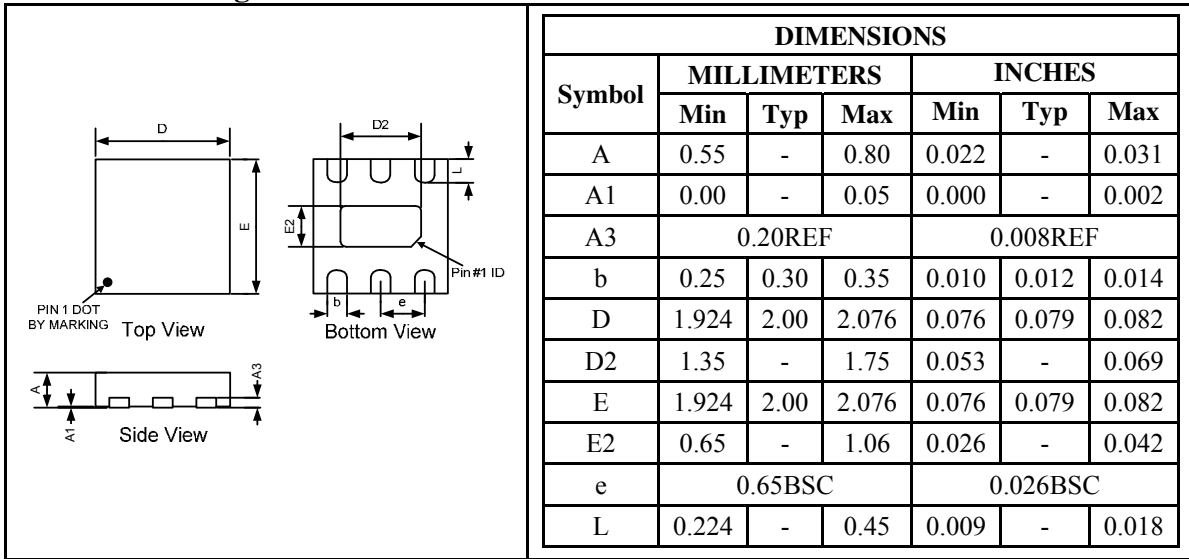
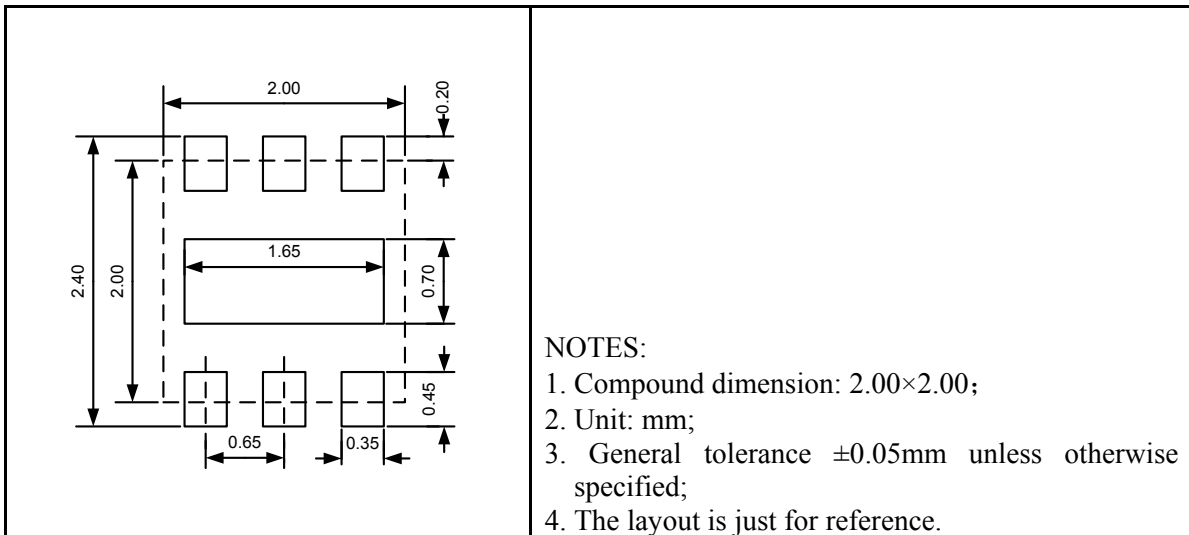
Land Pattern

Tape and Reel Orientation

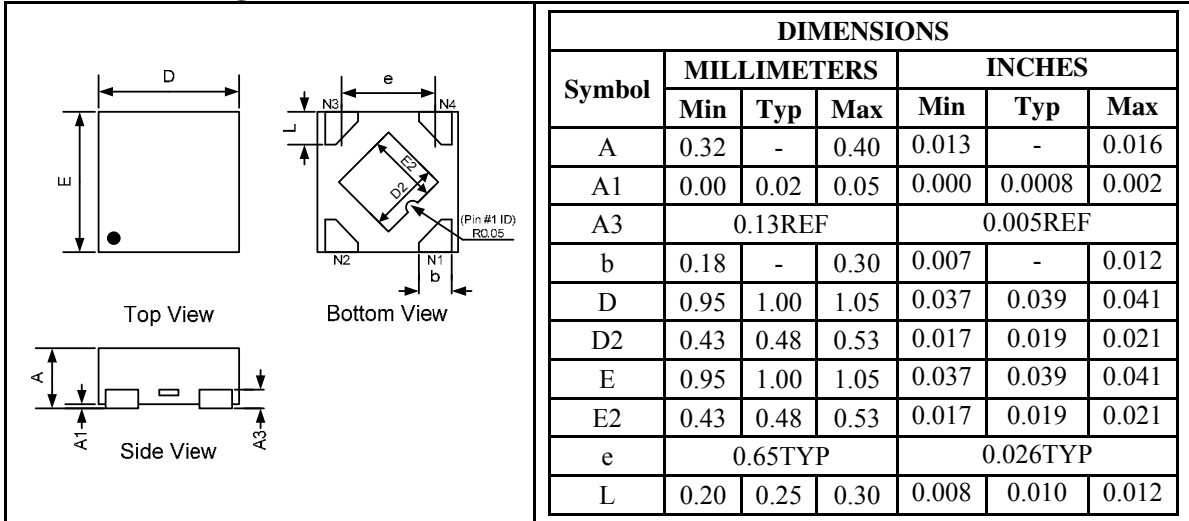

UM1550DA, UM1560DA: DFN6 2.0×2.0
Outline Drawing

Land Pattern

Tape and Reel Orientation

UM1550DB, UM1560DB: DFN4 1.0×1.0

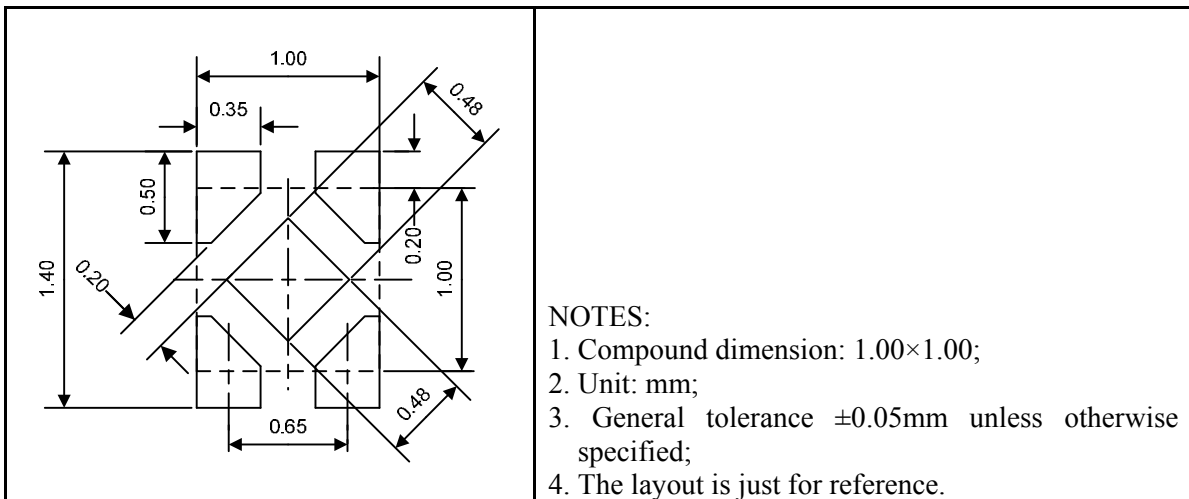
Outline Drawing



Land Pattern



Tape and Reel Orientation



UM1560S: SOT23-5

Outline Drawing

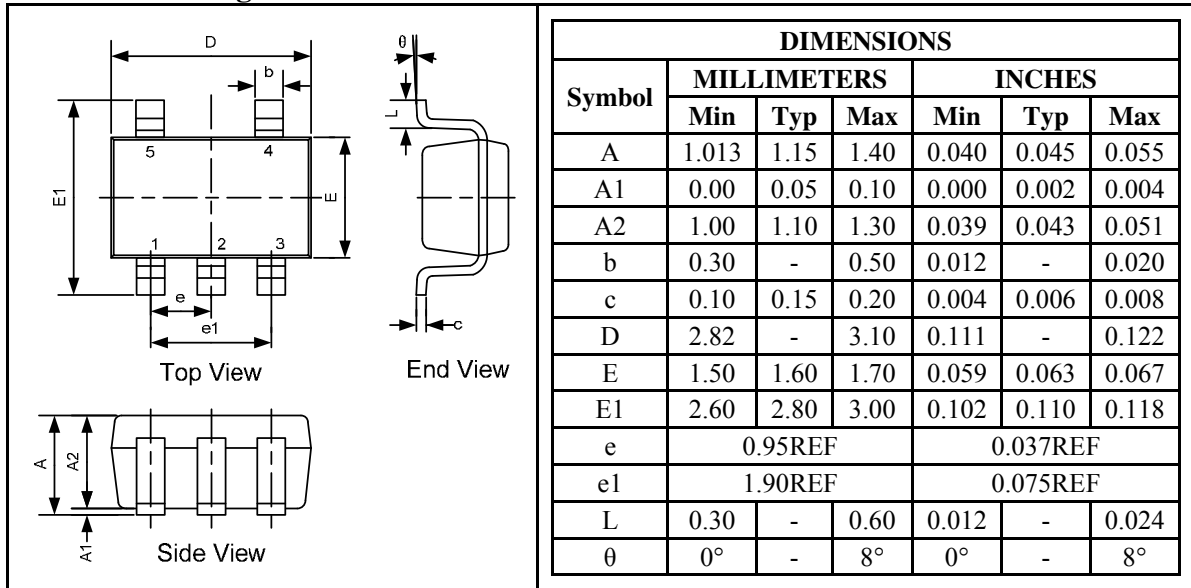

Land Pattern

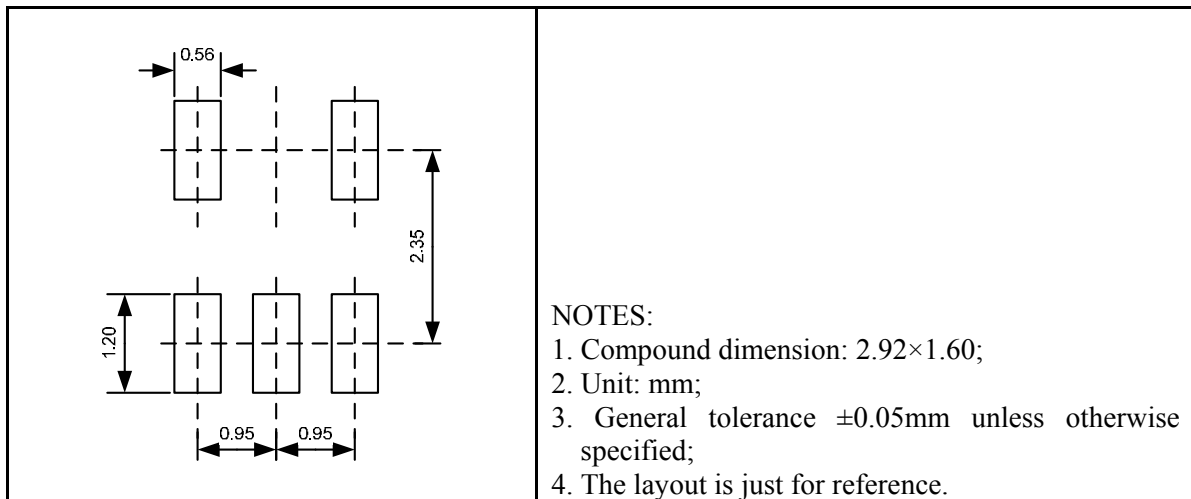

Tape and Reel Orientation

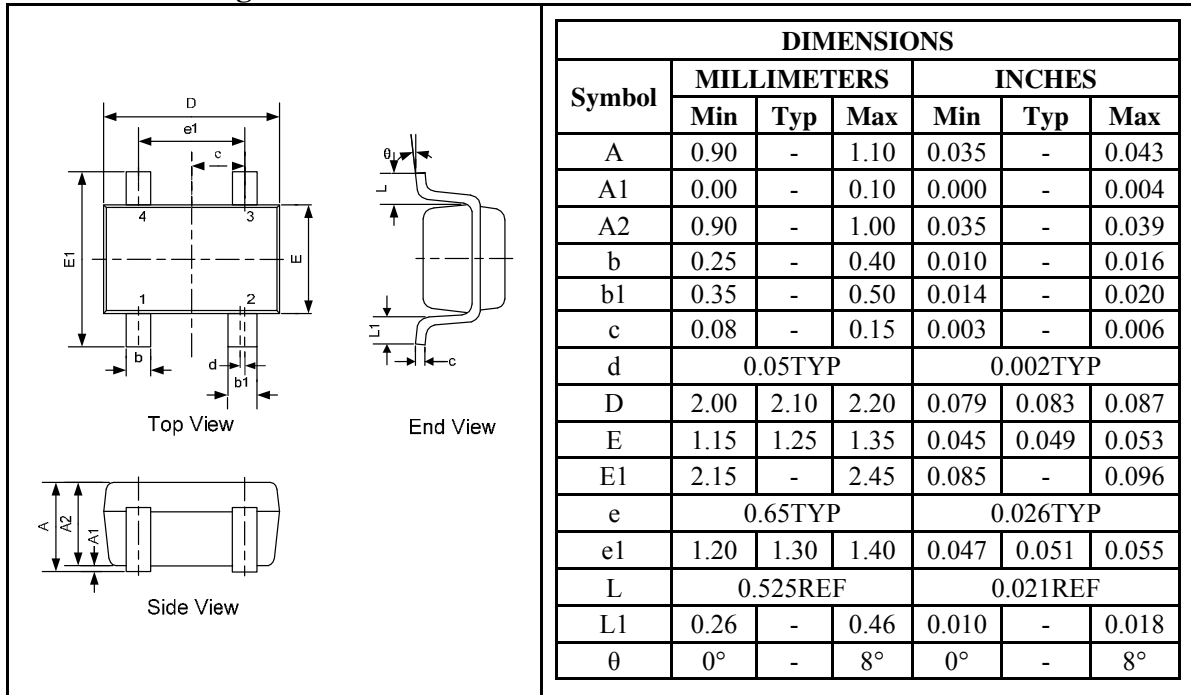
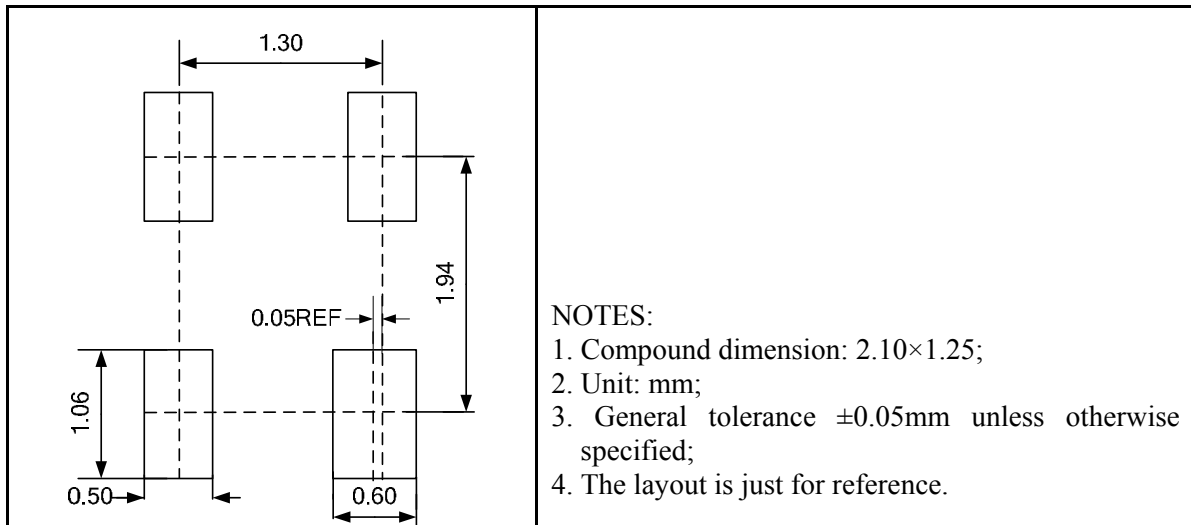

UM1560P: SOT343
Outline Drawing

Land Pattern

Tape and Reel Orientation

Ordering Information

Part Number	Output Voltage	Packaging Type	Marking Code	Shipping Qty
UM1550S-12	1.2V	SOT23-3	5B2	3000pcs/7Inch Tape & Reel
UM1550S-13	1.3V		5B3	
UM1550S-14	1.4V		5B4	
UM1550S-15	1.5V		5B5	
UM1550S-16	1.6V		5B6	
UM1550S-17	1.7V		5B7	
UM1550S-18	1.8V		5B8	
UM1550S-19	1.9V		5B9	
UM1550S-20	2.0V		5RF	
UM1550S-21	2.1V		5RH	
UM1550S-22	2.2V		5RL	
UM1550S-23	2.3V		5RM	
UM1550S-24	2.4V		5RJ	
UM1550S-25	2.5V		5RK	
UM1550S-26	2.6V		5RN	
UM1550S-27	2.7V		5RP	
UM1550S-28	2.8V		5RQ	
UM1550S-29	2.9V		5RR	
UM1550S-30	3.0V		5RS	
UM1550S-31	3.1V		5RT	
UM1550S-32	3.2V		5RY	
UM1550S-33	3.3V		5RU	
UM1550S-34	3.4V		5RZ	
UM1550S-35	3.5V		5A5	
UM1550S-36	3.6V		5A6	
UM1550S-37	3.7V		5A7	
UM1550S-38	3.8V		5A8	
UM1550S-39	3.9V		5A9	
UM1550S-40	4.0V		5AL	
UM1550S-41	4.1V		5AM	
UM1550S-42	4.2V	5L2		
UM1550S-43	4.3V	5L3		
UM1550S-44	4.4V	5L4		
UM1550S-45	4.5V	5L5		
UM1550S-46	4.6V	5L6		
UM1550S-47	4.7V	5L7		
UM1550S-48	4.8V	5L8		
UM1550S-49	4.9V	5L9		
UM1550S-50	5.0V	5AY		

Ordering Information (Continued)

Part Number	Output Voltage	Packaging Type	Marking Code	Shipping Qty
UM1550Y-12	1.2V	SOT89-3	CA2	1000pcs/7Inch Tape & Reel
UM1550Y-13	1.3V		CA3	
UM1550Y-14	1.4V		CA4	
UM1550Y-15	1.5V		CA5	
UM1550Y-16	1.6V		CA6	
UM1550Y-17	1.7V		CA7	
UM1550Y-18	1.8V		CA8	
UM1550Y-19	1.9V		CA9	
UM1550Y-20	2.0V		CAA	
UM1550Y-21	2.1V		CAB	
UM1550Y-22	2.2V		CB2	
UM1550Y-23	2.3V		CB3	
UM1550Y-24	2.4V		CB4	
UM1550Y-25	2.5V		CB5	
UM1550Y-26	2.6V		CB6	
UM1550Y-27	2.7V		CB7	
UM1550Y-28	2.8V		CB8	
UM1550Y-29	2.9V		CB9	
UM1550Y-30	3.0V		CBA	
UM1550Y-31	3.1V		CBB	
UM1550Y-32	3.2V		CC2	
UM1550Y-33	3.3V		CC3	
UM1550Y-34	3.4V		CC4	
UM1550Y-35	3.5V		CC5	
UM1550Y-36	3.6V		CC6	
UM1550Y-37	3.7V		CC7	
UM1550Y-38	3.8V		CC8	
UM1550Y-39	3.9V		CC9	
UM1550Y-40	4.0V		CCA	
UM1550Y-41	4.1V		CCB	
UM1550Y-42	4.2V		CD2	
UM1550Y-43	4.3V		CD3	
UM1550Y-44	4.4V		CD4	
UM1550Y-45	4.5V		CD5	
UM1550Y-46	4.6V		CD6	
UM1550Y-47	4.7V		CD7	
UM1550Y-48	4.8V		CD8	
UM1550Y-49	4.9V		CD9	
UM1550Y-50	5.0V		CDA	

Ordering Information (Continued)

Part Number	Output Voltage	Packaging Type	Marking Code	Shipping Qty
UM1550B-12	1.2V	SOT89-3	CAC	1000pcs/7Inch Tape & Reel
UM1550B-13	1.3V		CAD	
UM1550B-14	1.4V		CAE	
UM1550B-15	1.5V		CAF	
UM1550B-16	1.6V		CAH	
UM1550B-17	1.7V		CAL	
UM1550B-18	1.8V		CAM	
UM1550B-19	1.9V		CAJ	
UM1550B-20	2.0V		CAK	
UM1550B-21	2.1V		CAN	
UM1550B-22	2.2V		CAP	
UM1550B-23	2.3V		CAQ	
UM1550B-24	2.4V		CAR	
UM1550B-25	2.5V		CAS	
UM1550B-26	2.6V		CAT	
UM1550B-27	2.7V		CAY	
UM1550B-28	2.8V		CAU	
UM1550B-29	2.9V		CAZ	
UM1550B-30	3.0V		CBC	
UM1550B-31	3.1V		CBD	
UM1550B-32	3.2V		CBE	
UM1550B-33	3.3V		CBF	
UM1550B-34	3.4V		CBH	
UM1550B-35	3.5V		CBL	
UM1550B-36	3.6V		CBM	
UM1550B-37	3.7V		CBJ	
UM1550B-38	3.8V		CBK	
UM1550B-39	3.9V		CBN	
UM1550B-40	4.0V		CBP	
UM1550B-41	4.1V		CBQ	
UM1550B-42	4.2V		CBR	
UM1550B-43	4.3V		CBS	
UM1550B-44	4.4V		CBT	
UM1550B-45	4.5V		CBY	
UM1550B-46	4.6V		CBU	
UM1550B-47	4.7V		CBZ	
UM1550B-48	4.8V		CCC	
UM1550B-49	4.9V		CCD	
UM1550B-50	5.0V		CCE	

Ordering Information (Continued)

Part Number	Output Voltage	Packaging Type	Marking Code	Shipping Qty
UM1550DA-12	1.2V	DFN6 2.0×2.0	AH2	3000pcs/7Inch Tape & Reel
UM1550DA-13	1.3V		AH3	
UM1550DA-14	1.4V		AH4	
UM1550DA-15	1.5V		AH5	
UM1550DA-16	1.6V		AH6	
UM1550DA-17	1.7V		AH7	
UM1550DA-18	1.8V		AH8	
UM1550DA-19	1.9V		AH9	
UM1550DA-20	2.0V		AHA	
UM1550DA-21	2.1V		AHB	
UM1550DA-22	2.2V		AHC	
UM1550DA-23	2.3V		AHD	
UM1550DA-24	2.4V		AHE	
UM1550DA-25	2.5V		AHF	
UM1550DA-26	2.6V		AHG	
UM1550DA-27	2.7V		AHH	
UM1550DA-28	2.8V		AHJ	
UM1550DA-29	2.9V		AHK	
UM1550DA-30	3.0V		AHL	
UM1550DA-31	3.1V		AHN	
UM1550DA-32	3.2V		AHP	
UM1550DA-33	3.3V		AHQ	
UM1550DA-34	3.4V		AHR	
UM1550DA-35	3.5V		AHS	
UM1550DA-36	3.6V		AHT	
UM1550DA-37	3.7V		AHU	
UM1550DA-38	3.8V		AHV	
UM1550DA-39	3.9V		AHZ	
UM1550DA-40	4.0V		AJA	
UM1550DA-41	4.1V		AJB	
UM1550DA-42	4.2V		AJ2	
UM1550DA-43	4.3V		AJ3	
UM1550DA-44	4.4V		AJ4	
UM1550DA-45	4.5V		AJ5	
UM1550DA-46	4.6V		AJ6	
UM1550DA-47	4.7V		AJ7	
UM1550DA-48	4.8V		AJ8	
UM1550DA-49	4.9V		AJ9	
UM1550DA-50	5.0V		AJC	

Ordering Information (Continued)

Part Number	Output Voltage	Packaging Type	Marking Code	Shipping Qty
UM1550DB-12	1.2V	DFN4 1.0×1.0	JD	10000pcs/7Inch Tape & Reel
UM1550DB-13	1.3V		JE	
UM1550DB-14	1.4V		JF	
UM1550DB-15	1.5V		JG	
UM1550DB-16	1.6V		JH	
UM1550DB-17	1.7V		JJ	
UM1550DB-18	1.8V		JK	
UM1550DB-19	1.9V		JL	
UM1550DB-20	2.0V		JN	
UM1550DB-21	2.1V		JP	
UM1550DB-22	2.2V		JQ	
UM1550DB-23	2.3V		JR	
UM1550DB-24	2.4V		JS	
UM1550DB-25	2.5V		JT	
UM1550DB-26	2.6V		JU	
UM1550DB-27	2.7V		JV	
UM1550DB-28	2.8V		JZ	
UM1550DB-29	2.9V		KD	
UM1550DB-30	3.0V		KE	
UM1550DB-31	3.1V		KF	
UM1550DB-32	3.2V		KG	
UM1550DB-33	3.3V		KH	
UM1550DB-34	3.4V		KJ	
UM1550DB-35	3.5V		KK	
UM1550DB-36	3.6V		KL	
UM1550DB-37	3.7V		KN	
UM1550DB-38	3.8V		KP	
UM1550DB-39	3.9V		KQ	
UM1550DB-40	4.0V		KR	
UM1550DB-41	4.1V		KS	
UM1550DB-42	4.2V		KT	
UM1550DB-43	4.3V		KU	
UM1550DB-44	4.4V	KV		
UM1550DB-45	4.5V	KZ		
UM1550DB-46	4.6V	ND		
UM1550DB-47	4.7V	NE		
UM1550DB-48	4.8V	NF		
UM1550DB-49	4.9V	NG		
UM1550DB-50	5.0V	NH		

Ordering Information (Continued)

Part Number	Output Voltage	Packaging Type	Marking Code	Shipping Qty
UM1560S-12	1.2V	SOT23-5	6D2	3000pcs/7Inch Tape & Reel
UM1560S-13	1.3V		6D3	
UM1560S-14	1.4V		6D4	
UM1560S-15	1.5V		6D5	
UM1560S-16	1.6V		6D6	
UM1560S-17	1.7V		6D7	
UM1560S-18	1.8V		6D8	
UM1560S-19	1.9V		6D9	
UM1560S-20	2.0V		6DA	
UM1560S-21	2.1V		6DB	
UM1560S-22	2.2V		6G2	
UM1560S-23	2.3V		6G3	
UM1560S-24	2.4V		6G4	
UM1560S-25	2.5V		6G5	
UM1560S-26	2.6V		6G6	
UM1560S-27	2.7V		6G7	
UM1560S-28	2.8V		6G8	
UM1560S-29	2.9V		6G9	
UM1560S-30	3.0V		6GA	
UM1560S-31	3.1V		6GB	
UM1560S-32	3.2V		6H2	
UM1560S-33	3.3V		6H3	
UM1560S-34	3.4V		6H4	
UM1560S-35	3.5V		6H5	
UM1560S-36	3.6V		6H6	
UM1560S-37	3.7V		6H7	
UM1560S-38	3.8V		6H8	
UM1560S-39	3.9V		6H9	
UM1560S-40	4.0V		6HA	
UM1560S-41	4.1V		6HB	
UM1560S-42	4.2V		6J2	
UM1560S-43	4.3V		6J3	
UM1560S-44	4.4V	6J4		
UM1560S-45	4.5V	6J5		
UM1560S-46	4.6V	6J6		
UM1560S-47	4.7V	6J7		
UM1560S-48	4.8V	6J8		
UM1560S-49	4.9V	6J9		
UM1560S-50	5.0V	6JA		

Ordering Information (Continued)

Part Number	Output Voltage	Packaging Type	Marking Code	Shipping Qty
UM1560P-12	1.2V	SOT343	U42	3000pcs/7Inch Tape & Reel
UM1560P-13	1.3V		U43	
UM1560P-14	1.4V		U44	
UM1560P-15	1.5V		U45	
UM1560P-16	1.6V		U46	
UM1560P-17	1.7V		U47	
UM1560P-18	1.8V		U48	
UM1560P-19	1.9V		U49	
UM1560P-20	2.0V		U4A	
UM1560P-21	2.1V		U4B	
UM1560P-22	2.2V		U4C	
UM1560P-23	2.3V		U4D	
UM1560P-24	2.4V		U4E	
UM1560P-25	2.5V		U4F	
UM1560P-26	2.6V		U4H	
UM1560P-27	2.7V		U4L	
UM1560P-28	2.8V		U4M	
UM1560P-29	2.9V		U4J	
UM1560P-30	3.0V		U4K	
UM1560P-31	3.1V		U4N	
UM1560P-32	3.2V		U4P	
UM1560P-33	3.3V		U4Q	
UM1560P-34	3.4V		U4R	
UM1560P-35	3.5V		U4S	
UM1560P-36	3.6V		U4T	
UM1560P-37	3.7V		U4Y	
UM1560P-38	3.8V		U4U	
UM1560P-39	3.9V		U4Z	
UM1560P-40	4.0V		U5A	
UM1560P-41	4.1V		U5B	
UM1560P-42	4.2V		U52	
UM1560P-43	4.3V		U53	
UM1560P-44	4.4V		U54	
UM1560P-45	4.5V	U55		
UM1560P-46	4.6V	U56		
UM1560P-47	4.7V	U57		
UM1560P-48	4.8V	U58		
UM1560P-49	4.9V	U59		
UM1560P-50	5.0V	U5C		

Ordering Information (Continued)

Part Number	Output Voltage	Packaging Type	Marking Code	Shipping Qty
UM1560DA-12	1.2V	DFN6 2.0×2.0	AK2	3000pcs/7Inch Tape & Reel
UM1560DA-13	1.3V		AK3	
UM1560DA-14	1.4V		AK4	
UM1560DA-15	1.5V		AK5	
UM1560DA-16	1.6V		AK6	
UM1560DA-17	1.7V		AK7	
UM1560DA-18	1.8V		AK8	
UM1560DA-19	1.9V		AK9	
UM1560DA-20	2.0V		AKA	
UM1560DA-21	2.1V		AKB	
UM1560DA-22	2.2V		AKC	
UM1560DA-23	2.3V		AKD	
UM1560DA-24	2.4V		AKE	
UM1560DA-25	2.5V		AKF	
UM1560DA-26	2.6V		AKG	
UM1560DA-27	2.7V		AKH	
UM1560DA-28	2.8V		AKJ	
UM1560DA-29	2.9V		AKK	
UM1560DA-30	3.0V		AKL	
UM1560DA-31	3.1V		AKN	
UM1560DA-32	3.2V		AKP	
UM1560DA-33	3.3V		AKQ	
UM1560DA-34	3.4V		AKR	
UM1560DA-35	3.5V		AKS	
UM1560DA-36	3.6V		AKT	
UM1560DA-37	3.7V		AKU	
UM1560DA-38	3.8V		AKV	
UM1560DA-39	3.9V		AKZ	
UM1560DA-40	4.0V		ANA	
UM1560DA-41	4.1V		ANB	
UM1560DA-42	4.2V		AN2	
UM1560DA-43	4.3V		AN3	
UM1560DA-44	4.4V		AN4	
UM1560DA-45	4.5V		AN5	
UM1560DA-46	4.6V		AN6	
UM1560DA-47	4.7V		AN7	
UM1560DA-48	4.8V		AN8	
UM1560DA-49	4.9V		AN9	
UM1560DA-50	5.0V		ANC	

Ordering Information (Continued)

Part Number	Output Voltage	Packaging Type	Marking Code	Shipping Qty
UM1560DB-12	1.2V	DFN4 1.0×1.0	D2	10000pcs/7Inch Tape & Reel
UM1560DB-13	1.3V		D3	
UM1560DB-14	1.4V		D4	
UM1560DB-15	1.5V		D5	
UM1560DB-16	1.6V		D6	
UM1560DB-17	1.7V		D7	
UM1560DB-18	1.8V		D8	
UM1560DB-19	1.9V		D9	
UM1560DB-20	2.0V		DA	
UM1560DB-21	2.1V		DB	
UM1560DB-22	2.2V		F2	
UM1560DB-23	2.3V		F3	
UM1560DB-24	2.4V		F4	
UM1560DB-25	2.5V		F5	
UM1560DB-26	2.6V		F6	
UM1560DB-27	2.7V		F7	
UM1560DB-28	2.8V		F8	
UM1560DB-29	2.9V		F9	
UM1560DB-30	3.0V		FA	
UM1560DB-31	3.1V		FB	
UM1560DB-32	3.2V		H2	
UM1560DB-33	3.3V		H3	
UM1560DB-34	3.4V		H4	
UM1560DB-35	3.5V		H5	
UM1560DB-36	3.6V		H6	
UM1560DB-37	3.7V		H7	
UM1560DB-38	3.8V		H8	
UM1560DB-39	3.9V		H9	
UM1560DB-40	4.0V		HA	
UM1560DB-41	4.1V		HB	
UM1560DB-42	4.2V	P2		
UM1560DB-43	4.3V	P3		
UM1560DB-44	4.4V	P4		
UM1560DB-45	4.5V	P5		
UM1560DB-46	4.6V	P6		
UM1560DB-47	4.7V	P7		
UM1560DB-48	4.8V	P8		
UM1560DB-49	4.9V	P9		
UM1560DB-50	5.0V	PA		

GREEN COMPLIANCE

Union Semiconductor is committed to environmental excellence in all aspects of its operations including meeting or exceeding regulatory requirements with respect to the use of hazardous substances. Numerous successful programs have been implemented to reduce the use of hazardous substances and/or emissions.

All Union components are compliant with the RoHS directive, which helps to support customers in their compliance with environmental directives. For more green compliance information, please visit:

http://www.union-ic.com/index.aspx?cat_code=RoHSDeclaration

IMPORTANT NOTICE

The information in this document has been carefully reviewed and is believed to be accurate. Nonetheless, this document is subject to change without notice. Union assumes no responsibility for any inaccuracies that may be contained in this document, and makes no commitment to update or to keep current the contained information, or to notify a person or organization of any update. Union reserves the right to make changes, at any time, in order to improve reliability, function or design and to attempt to supply the best product possible.



Union Semiconductor, Inc

Add: Unit 606, No.570 Shengxia Road, Shanghai 201210

Tel: 021-51093966

Fax: 021-51026018

Website: www.union-ic.com