

Adjustable inverting negative output current mode PWM regulators

Features

- 2.7V to 11V input to adjustable negative output conversion
- 1W guaranteed output power ($V_I > 4.5V$, $T_A \leq 70^\circ C$)
- 68% typ. efficiency at 6V
- Very low quiescent current: 1.2mA in on mode, 10 μ A in shut down mode
- Soft start
- Very low noise output
- 160KHz fixed frequency oscillator
- Mixed bipolar-CMOS technology

Description

The ST755 is an adjustable inverting switch-mode DC-DC regulator with internal Power MOSFET that generates an adjustable negative output from a voltage input of 2.7V to 11V, output current guaranteed at 200mA (for $V_I > 4.5V$, $V_O = -5V$

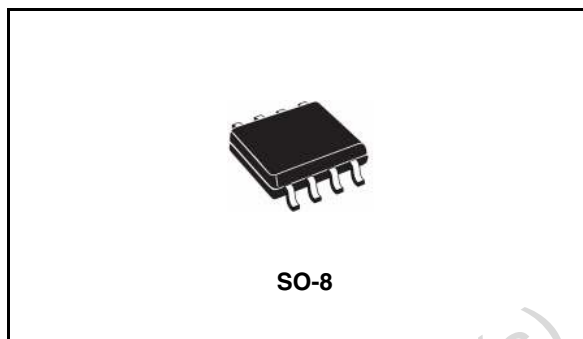

and $T_A = 0^\circ C$ to $70^\circ C$) and 275mA (typical value at $T_A = 25^\circ C$, $V_O = -5V$).

A logic controlled shut down pin that interfaces directly with microprocessor reduces supply current to only 10mA. Input to Output differential voltage is limited to $|V_I + V_O| < 12.7V$. No load supply current is 1.2mA

Table 1. Device summary

Part number	Package	Packaging
ST755C	ST755CD-TR	SO-8 (tape & reel)

Contents

1	Diagram	3
2	Pin configuration	4
3	Maximum ratings	5
4	Electrical characteristics	6
5	Application information	7
6	Application circuit	8
7	Typical performance characteristics	10
8	Package mechanical data	12
9	Revision history	15

1 Diagram

Figure 1. Schematic diagram

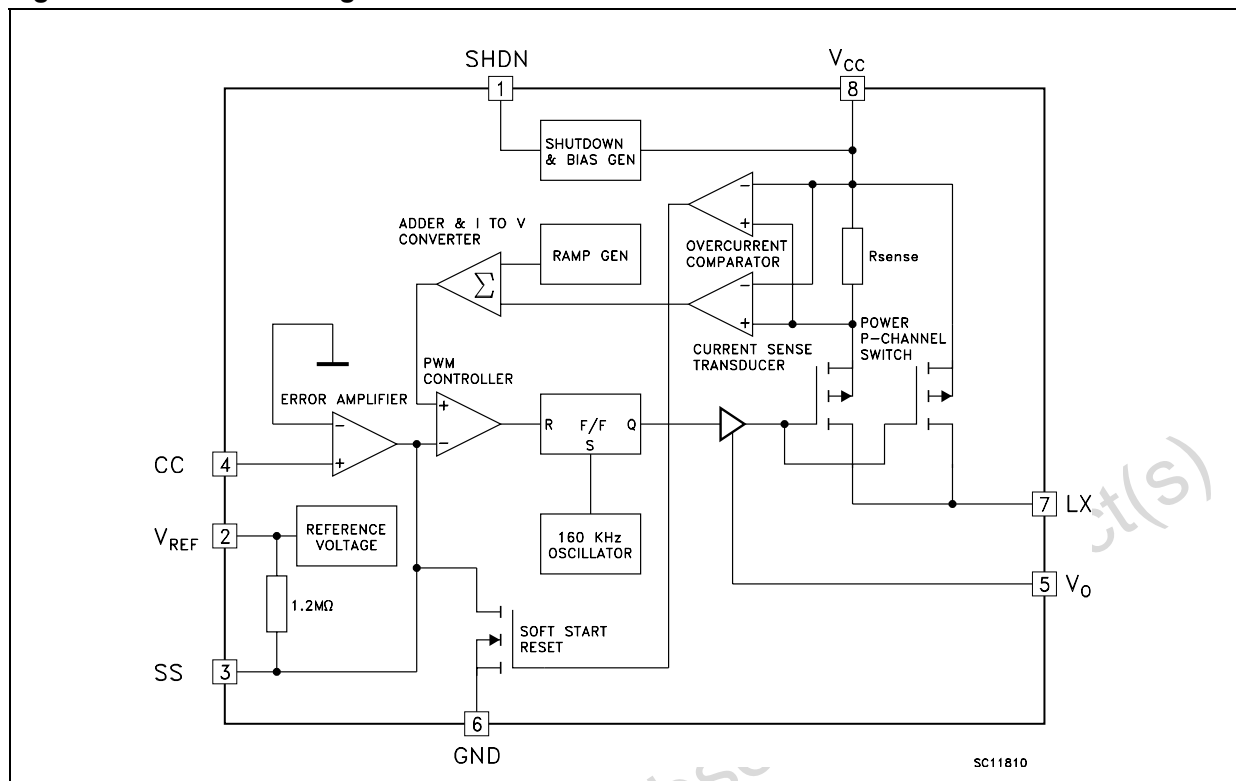

Obsolete Product(s) - Obs

2 Pin configuration

Figure 2. Pin connections (top view)

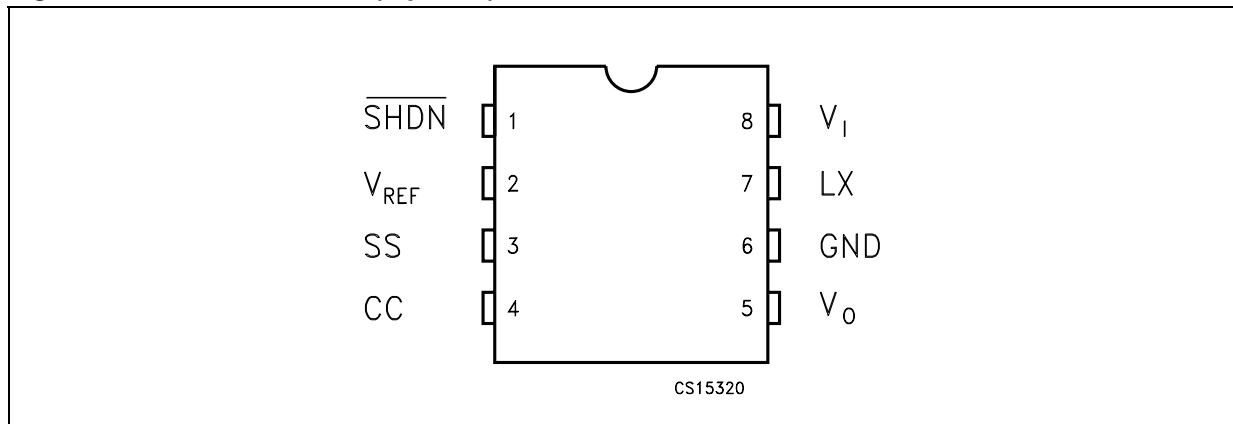

Table 2. Pin description

Pin N°	Symbol	Name and function
1	$\overline{\text{SHDN}}$	SHUT-DOWN control ($V_{CC} = \text{ON}$, $\text{GND} = \text{Shutdown}$)
2	V_{REF}	Reference output voltage: (1.25V)
3	SS	Soft start
4	CC	Compensation input
5	V_{O}	Negative output voltage
6	GND	Ground
7	LX	Switch output
8	V_{CC}	Supply voltage input

3 Maximum ratings

Table 3. Absolute maximum ratings

Symbol	Parameter	Value	Unit
V_{CC}	DC input voltage to GND ⁽¹⁾	-0.3 to 12	V
V_{SHDN}	Shutdown voltage, SS Voltage, CC Voltage	-0.3 to ($V_{CC} + 0.3$)	V
V_{LX}	Switch voltage (LX to V_{CC})	-12.5 to + 0.3	V
V_{FB}	Feedback voltage (V_O to GND)	-11 to + 0.9	V
I_{LX}	Peak switch current	2	A
P_{TOT}	Continuous power dissipation at $T_A = 70^\circ\text{C}$ (SO-8)	470	mW
T_{op}	Operating junction temperature range (C series)	-40 to 185	$^\circ\text{C}$
T_{stg}	Storage temperature range	-55 to +150	$^\circ\text{C}$

1. The input to output differential voltage is limited to $V_{CC} + |V_O| < 12.7\text{V}$

Note: Absolute Maximum Ratings are those values beyond which damage to the device may occur. Functional operation under these condition is not implied

Table 4. Thermal data

Symbol	Parameter	SO-8	Unit
R_{thJA}	Thermal resistance junction-ambient ⁽¹⁾	160	$^\circ\text{C}/\text{W}$

1. This value depends from thermal design of PCB on which the device is mounted.

4 Electrical characteristics

Table 5. Electrical characteristics (Refer to the test circuits, $V_{CC} = 5V$, $V_O = -5.25$ to $-4.75V$, $I_{LOAD} = 0mA$, $T_A = T_{MIN}$ to T_{MAX} , unless otherwise specified. Typical value are referred at $T_A = 25^\circ C$)

Symbol	Parameter	Test conditions	Min.	Typ.	Max.	Unit
V_I	Input voltage		4		11	V
V_O	Output voltage	$V_{CC} = 4.5$ to $6.2V$, $I_O = 0$ to $200mA$	4.75	5	5.25	V
I_O	Output current	$V_{CC} = 4.5$ to $6.2V$, $T_A = 0$ to $70^\circ C$	200	275		mA
		$V_{CC} = 4.5$ to $6.2V$, $T_A = -40$ to $85^\circ C$	175			
		$V_{CC} = 4V$, $V_O = -5V$		175		
		$V_{CC} = 2.7V$, $V_O = -5V$		125		
I_{SUPPLY}	Supply current (including switching current)	No Load, $V_{SHDN} = V_{CC}$		1.2	3.5	mA
I_{OFF}	Standby current)	No Load, $V_{SHDN} = 0V$		10	100	μA
I_{SC}	Short circuit current)			1.2		A
ΔV_O	Line regulation	$V_{CC} = 4$ to $6.2V$		0.1		%/V
ΔV_O	Load regulation	$I_O = 0$ to $200mA$		0.003		%/mA
V_{REF}	Reference voltage	$T_A = 25^\circ C$	1.18	1.25	1.32	V
ΔV_{REF}	Reference drift	$T_A = T_{MIN}$ to T_{MAX}		50		ppm/ $^\circ C$
R_{DSON}	LX on resistance			0.7		Ω
I_{LEAK}	LX leakage current)	$V_{DS} = 10V$		1		μA
I_{SH}	Shutdown pin current)				1	μA
V_{IH}	SHDN input high threshold		2			V
V_{IL}	SHDN input low threshold				0.25	V
f_{OSC}	Oscillator frequency			160		KHz
h	Power efficiency	$I_O = 100mA$		68		%
CC	Compensation pin impedance			7.5		K Ω

Note: Do not overload or short the Output to Ground. If the above conditions are observed, the device may be damaged.

5 Application information

The ST755 is an IC developed for voltage conversion from an input voltage ranging from +2.4V to 11V to a regulated adjustable negative output limited by $|V_{O}| \leq 12.7V - V_I$. The circuit adopts a current-mode PWM control scheme to achieve good efficiency, high stability and low noise performance. The figure in the first page shown the detailed block diagram of the device.

ST755 is realized in a BCD technology in order to achieve high temperature stability, the best REFERENCE precision, a very low quiescent current and jitter free operations. The final stage is built around a 0.7 Ω - 2A P-Channel Power MOS. A fraction of the output current is splitted out for current detection. Internal clock frequency is fixed to 160KHz. Error amplifier drives the PWM comparator in order to keep 0V on the CC input. So R_3 and R_4 resistors are calculated by the following formulae $R_4 = (|V_O|/V_{REF}) * R_3$ (see [Figure 3](#)). For R_3 can be choose any value between 2K Ω and 20K Ω Soft-Start (SS) input is a voltage dependent-output current limit (see [Figure 11](#), Switch Current Limit vs. SS Input Voltage). SS pin is internally pulled to V_{REF} through a 1.2 M Ω resistor. Applying an appropriate capacitor at SS input is possible to obtain a soft-start current imitation during power up. Forcing Soft-Start (SS) input to a lower voltage through a resistive voltage driver (R_1 and R_2), the maximum LX current limit can be lowered according the diagram showed in [Figure 11](#). When SHDN input is low, the total current consumption is reduced to 10 μ A.

6 Application circuit

To achieve the best performances from switching power supply topology, particular care to layout drawing is needed, in order to minimize EMI and obtain low noise, jitter free operation moreover, it ensures the full device functionality. Layout design proposed on demoboard (see [Figure 4.](#)) helps to lower the developing time. Wire lengths must be minimized, filter and by-pass capacitors C_1 , C_2 and C_3 must be low ESR type, placed as close possible to the integrated circuit. The $10\mu\text{H}$ inductor must be chosen built on a core, taking care that saturation current should be higher than the peak LX switch current. See the Peak inductor current vs. load current graph ([Figure 6.](#)).

Figure 3. Typical application circuit

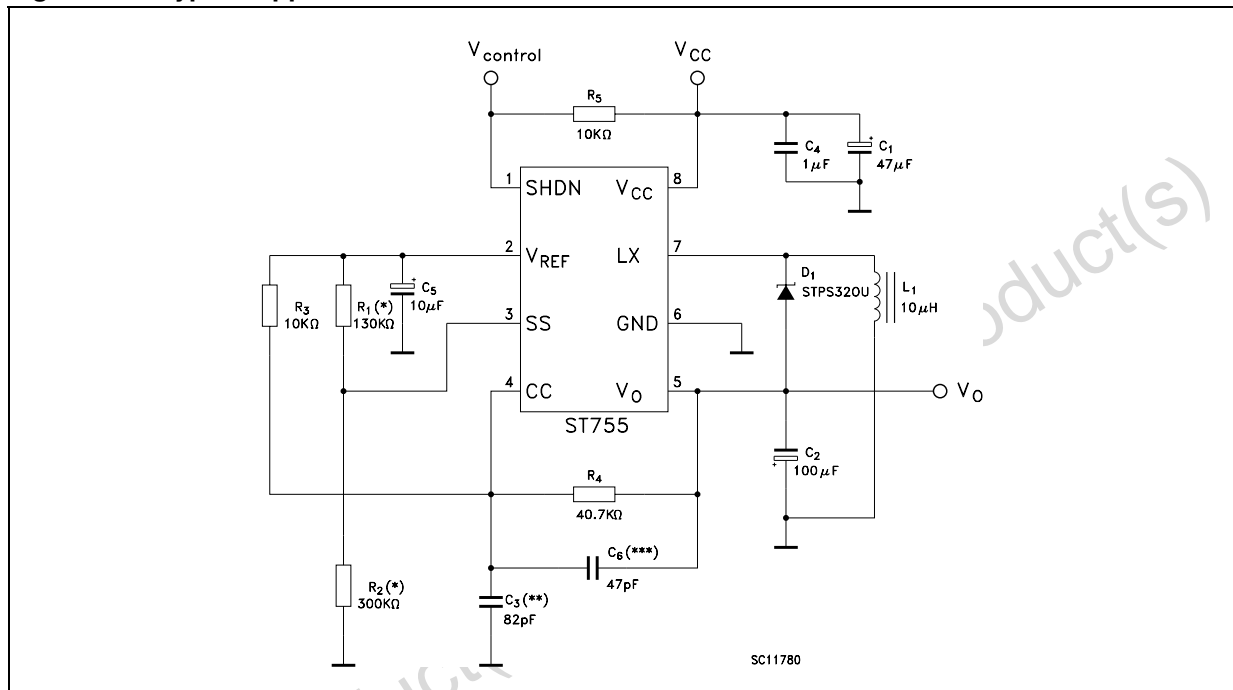

(*) R1 and R2 can be omitted for $I_O < 200\text{mA}$.

(**) C6: Very low noise but poor transient and load response speed.

(***) C3 (alternative to C6): faster transient and load response.

Figure 4. Printed demoboard

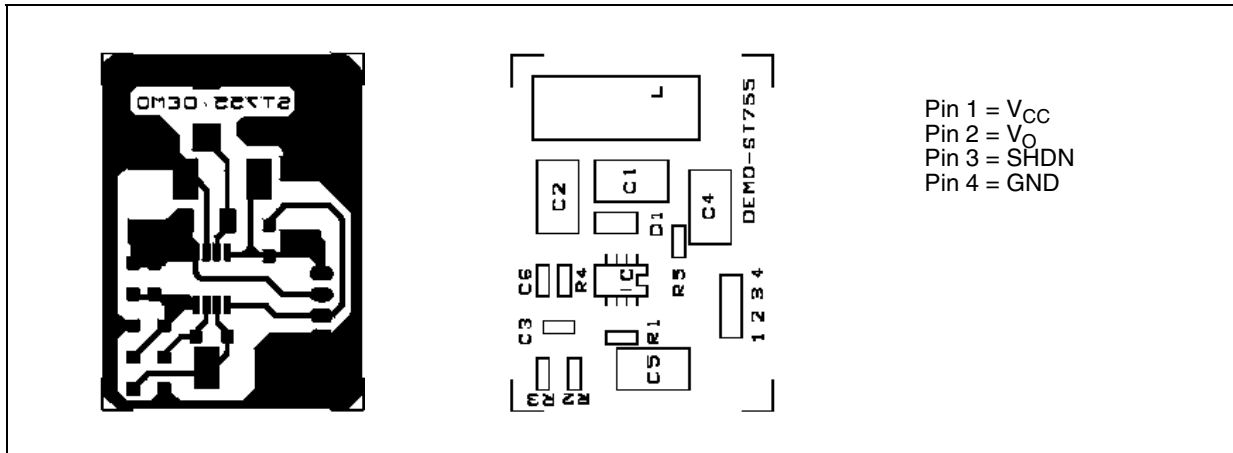

Note: Drawings not in scale

Table 6. Component values

Capacitor	Value	Unit	Resistor	Value	Unit
C1	47	μF	R1	130	$\text{K}\Omega$
C2	100	μF	R2	300	$\text{K}\Omega$
C3	82	pF	R3	10	$\text{K}\Omega$
C4	1	μF	R4	40.7	$\text{K}\Omega$
C5	10	μF	R5	10	$\text{K}\Omega$
C6	47	pF			

7 Typical performance characteristics

(Unless otherwise specified $T_J = 25^\circ\text{C}$)

Figure 5. Load current vs supply voltage

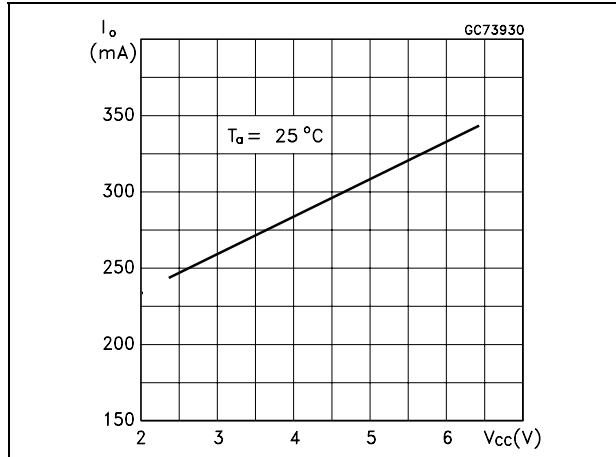

Figure 6. Peak inductor current vs load curr.

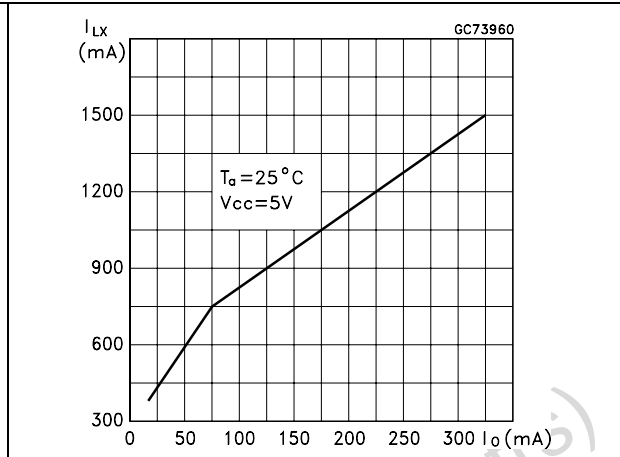

Figure 7. Load current vs supply voltage

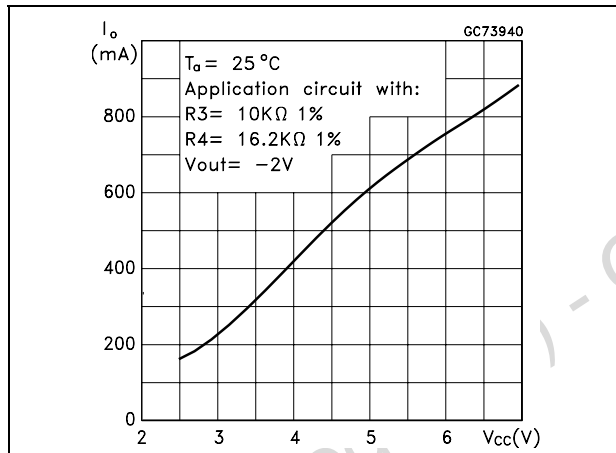

Figure 8. Switch ON resist. vs supply voltage

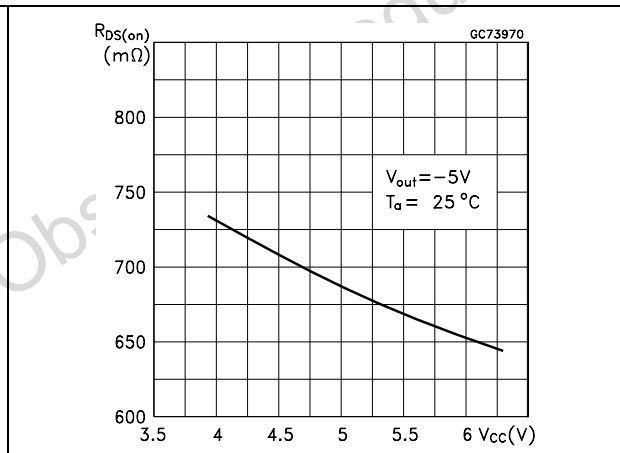

Figure 9. Efficiency vs load current

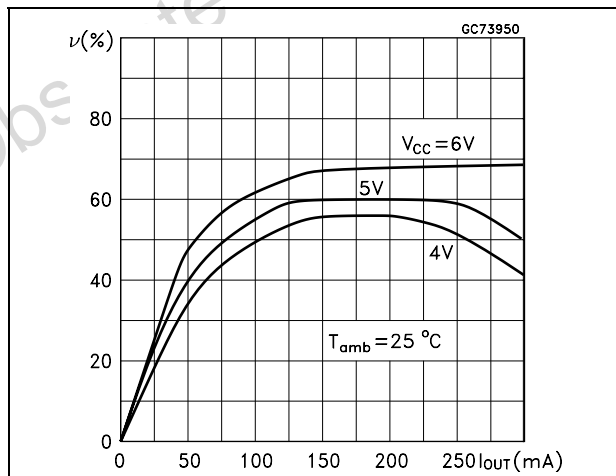

Figure 10. Oscillator frequency vs temperature & supply voltage

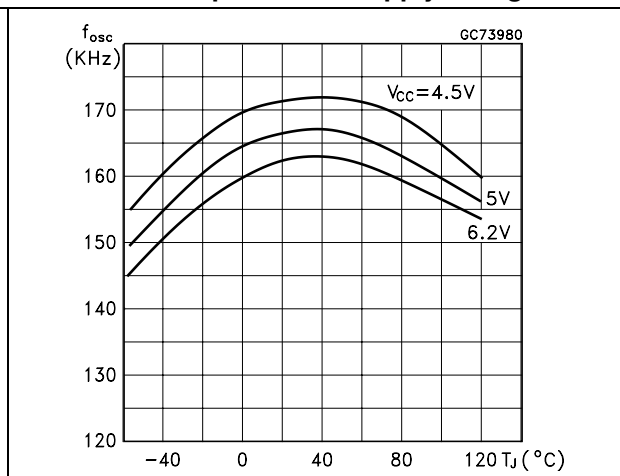

Figure 11. Switch current limit vs soft start voltage

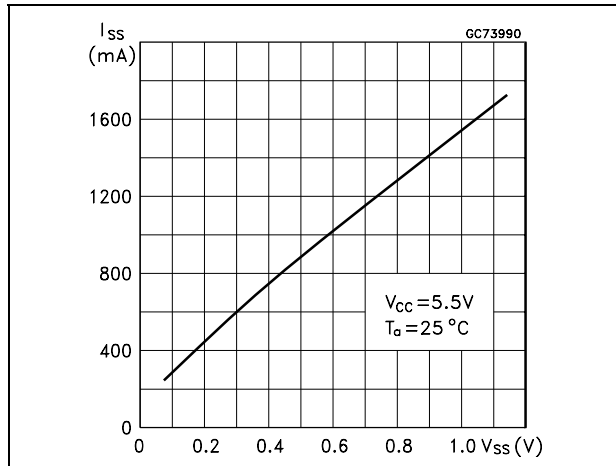

Figure 12. Reference voltage vs temperature

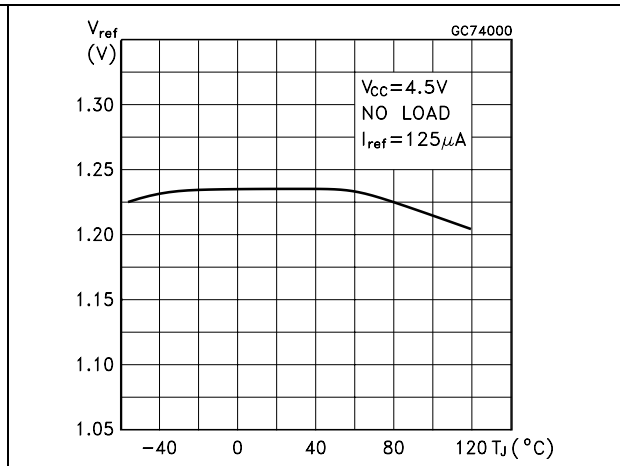
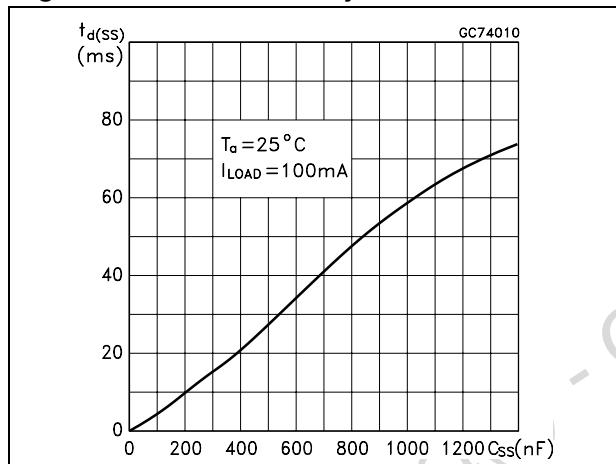

Figure 13. Soft start delay time



8 Package mechanical data

In order to meet environmental requirements, ST offers these devices in ECOPACK® packages. These packages have a Lead-free second level interconnect. The category of second Level Interconnect is marked on the package and on the inner box label, in compliance with JEDEC Standard JESD97. The maximum ratings related to soldering conditions are also marked on the inner box label. ECOPACK is an ST trademark. ECOPACK specifications are available at: www.st.com.

Obsolete Product(s) - Obsolete Product(s)

SO-8 MECHANICAL DATA

DIM.	mm.			inch		
	MIN.	TYP	MAX.	MIN.	TYP.	MAX.
A	1.35		1.75	0.053		0.069
A1	0.10		0.25	0.04		0.010
A2	1.10		1.65	0.043		0.065
B	0.33		0.51	0.013		0.020
C	0.19		0.25	0.007		0.010
D	4.80		5.00	0.189		0.197
E	3.80		4.00	0.150		0.157
e		1.27			0.050	
H	5.80		6.20	0.228		0.244
h	0.25		0.50	0.010		0.020
L	0.40		1.27	0.016		0.050
k	8° (max.)					
ddd			0.1			0.04

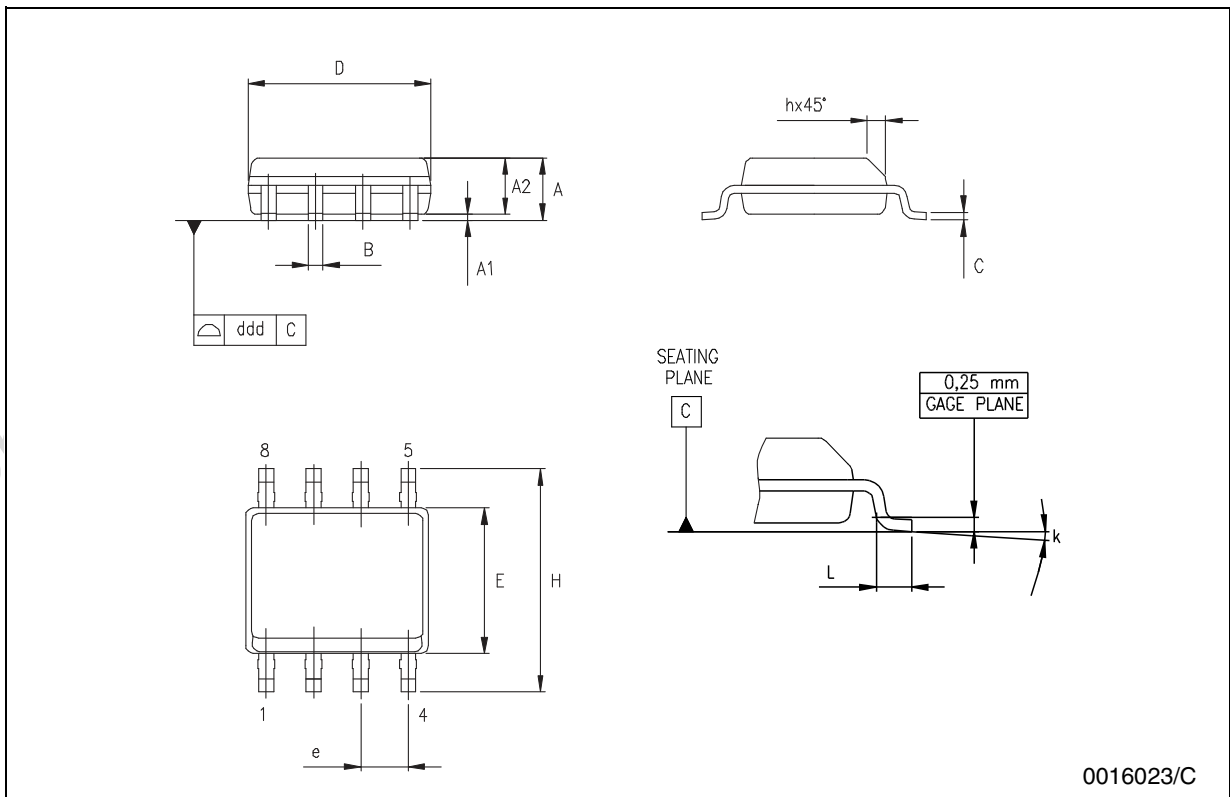

Tape & Reel SO-8 MECHANICAL DATA

DIM.	mm.			inch		
	MIN.	TYP	MAX.	MIN.	TYP.	MAX.
A			330			12.992
C	12.8		13.2	0.504		0.519
D	20.2			0.795		
N	60			2.362		
T			22.4			0.882
Ao	8.1		8.5	0.319		0.335
Bo	5.5		5.9	0.216		0.232
Ko	2.1		2.3	0.082		0.090
Po	3.9		4.1	0.153		0.161
P	7.9		8.1	0.311		0.319

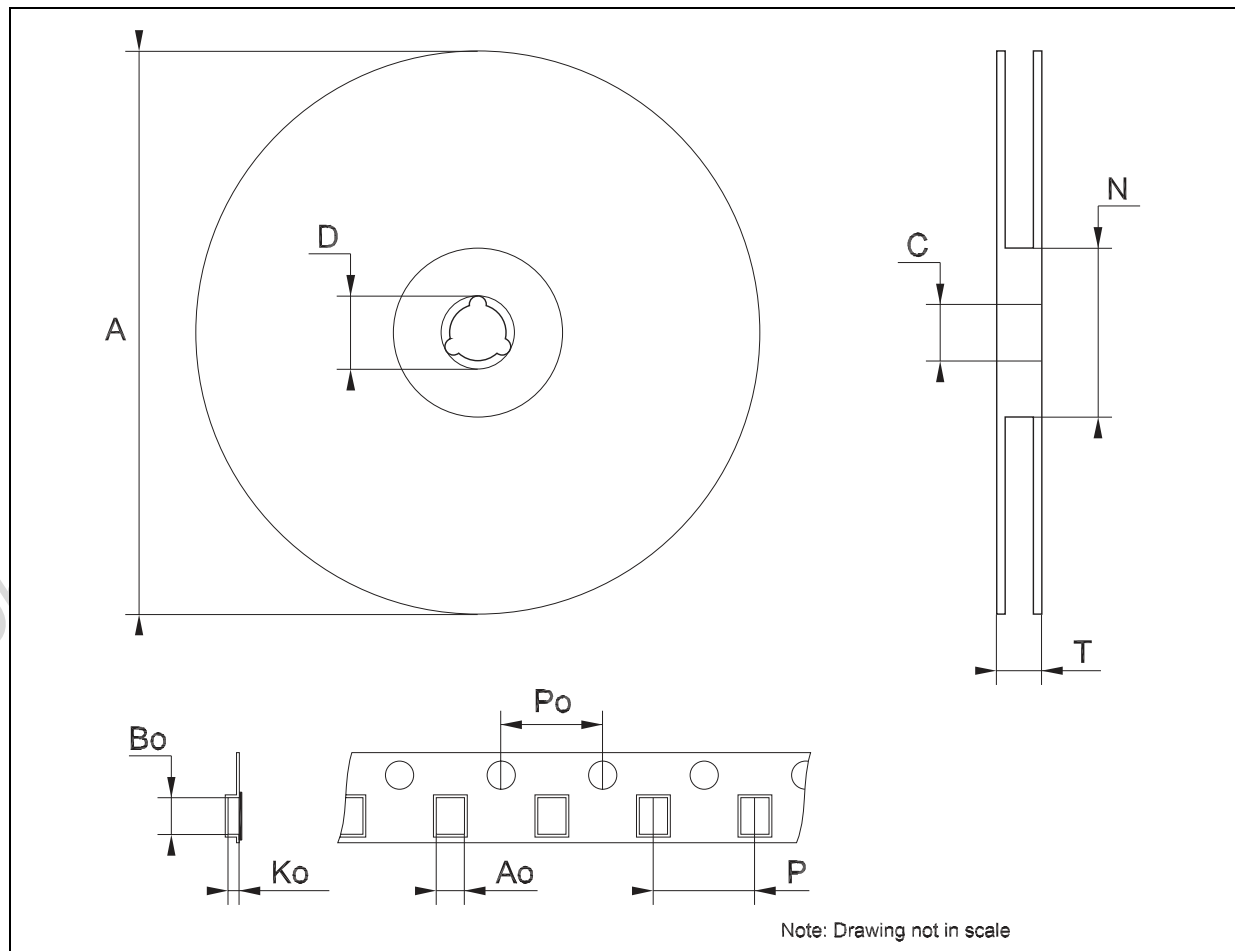

9 Revision history

Table 7. Revision history

Date	Revision	Changes
06-Jul-2007	5	Device summary updated and the document has been reformatted.

Obsolete Product(s) - Obsolete Product(s)

Please Read Carefully:

Information in this document is provided solely in connection with ST products. STMicroelectronics NV and its subsidiaries ("ST") reserve the right to make changes, corrections, modifications or improvements, to this document, and the products and services described herein at any time, without notice.

All ST products are sold pursuant to ST's terms and conditions of sale.

Purchasers are solely responsible for the choice, selection and use of the ST products and services described herein, and ST assumes no liability whatsoever relating to the choice, selection or use of the ST products and services described herein.

No license, express or implied, by estoppel or otherwise, to any intellectual property rights is granted under this document. If any part of this document refers to any third party products or services it shall not be deemed a license grant by ST for the use of such third party products or services, or any intellectual property contained therein or considered as a warranty covering the use in any manner whatsoever of such third party products or services or any intellectual property contained therein.

UNLESS OTHERWISE SET FORTH IN ST'S TERMS AND CONDITIONS OF SALE ST DISCLAIMS ANY EXPRESS OR IMPLIED WARRANTY WITH RESPECT TO THE USE AND/OR SALE OF ST PRODUCTS INCLUDING WITHOUT LIMITATION IMPLIED WARRANTIES OF MERCHANTABILITY, FITNESS FOR A PARTICULAR PURPOSE (AND THEIR EQUIVALENTS UNDER THE LAWS OF ANY JURISDICTION), OR INFRINGEMENT OF ANY PATENT, COPYRIGHT OR OTHER INTELLECTUAL PROPERTY RIGHT.

UNLESS EXPRESSLY APPROVED IN WRITING BY AN AUTHORIZED ST REPRESENTATIVE, ST PRODUCTS ARE NOT RECOMMENDED, AUTHORIZED OR WARRANTED FOR USE IN MILITARY, AIR CRAFT, SPACE, LIFE SAVING, OR LIFE SUSTAINING APPLICATIONS, NOR IN PRODUCTS OR SYSTEMS WHERE FAILURE OR MALFUNCTION MAY RESULT IN PERSONAL INJURY, DEATH, OR SEVERE PROPERTY OR ENVIRONMENTAL DAMAGE. ST PRODUCTS WHICH ARE NOT SPECIFIED AS "AUTOMOTIVE GRADE" MAY ONLY BE USED IN AUTOMOTIVE APPLICATIONS AT USER'S OWN RISK.

Resale of ST products with provisions different from the statements and/or technical features set forth in this document shall immediately void any warranty granted by ST for the ST product or service described herein and shall not create or extend in any manner whatsoever, any liability of ST.

ST and the ST logo are trademarks or registered trademarks of ST in various countries.

Information in this document supersedes and replaces all information previously supplied.

The ST logo is a registered trademark of STMicroelectronics. All other names are the property of their respective owners.

© 2007 STMicroelectronics - All rights reserved

STMicroelectronics group of companies

Australia - Belgium - Brazil - Canada - China - Czech Republic - Finland - France - Germany - Hong Kong - India - Israel - Italy - Japan - Malaysia - Malta - Morocco - Singapore - Spain - Sweden - Switzerland - United Kingdom - United States of America

www.st.com