

Introduction

The evaluation board is designed to help the customer evaluate the 5P49V5907/08, the latest addition to the family of programmable devices in IDT's Timing portfolio. When the board is connected to a PC running IDT Timing Commander™ Software through USB, the device can be configured and programmed to generate frequencies with best-in-class performances.

Board Overview

Use the following diagram and table to identify: power supply jacks, USB connector, input and output frequency SMA connectors.

Figure 1. Board Overview

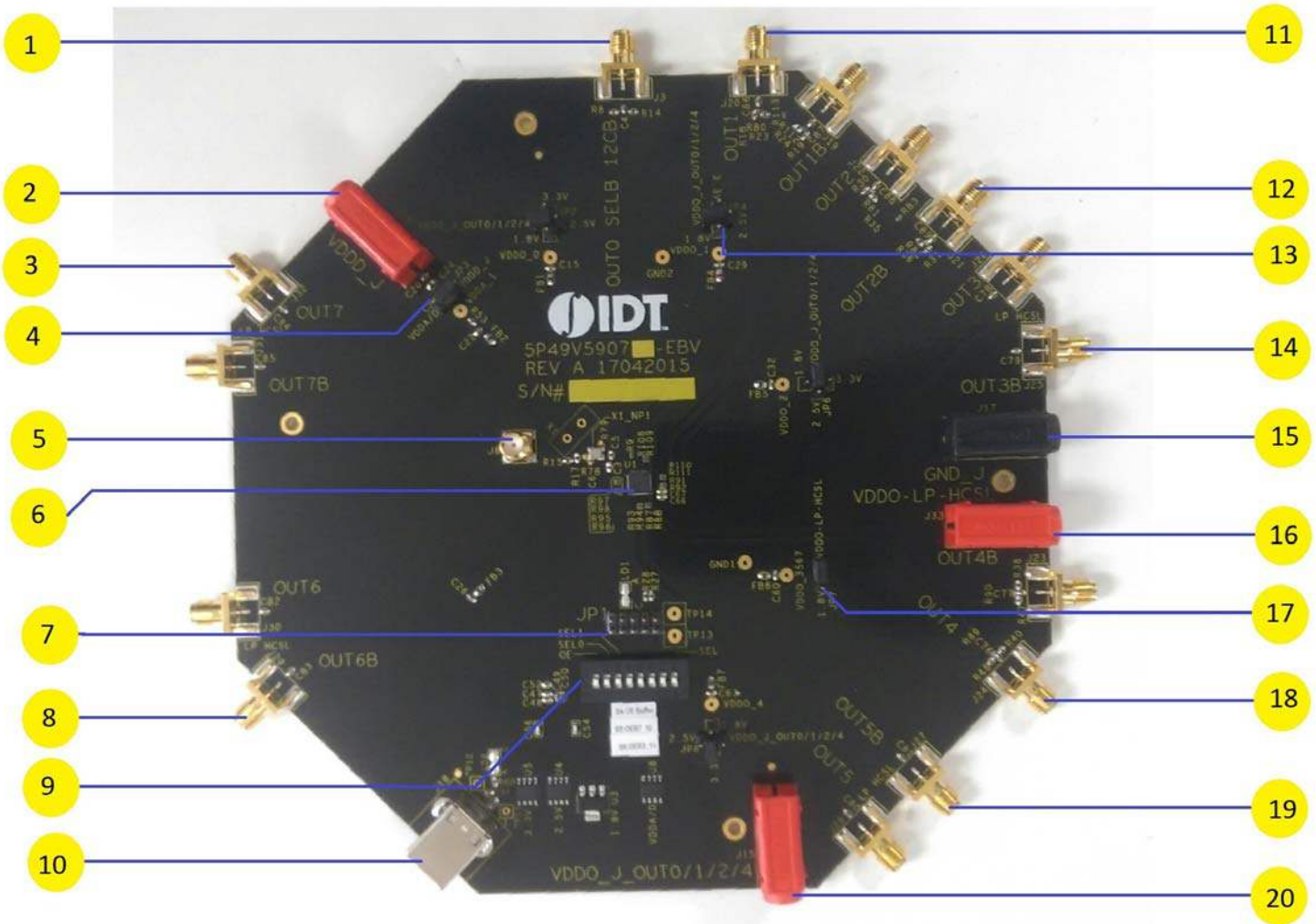

Table 1: EBV Pins and Functions

Item	Name	On-Board Connector Label	Function
1	Output 0	J3	Single ended buffered output of input reference clock
2	Power Supply Jack	J16	Connect 1.8V for the core voltage of the device
3	Output 7/7B	J32/31	Low Power HCSL differential output
4	Output Voltage Power Supply Selector	JP3	Provides selection of 1.8V supply from regulators or supply from J16
5	Xin	J6	Single ended clock input. Maximum full swing limited to 1.2V
6	5P49V5907/08	U1	Evaluation Device
7	Aardvark Connector	JP1	For Aardvark connection
8	Output 6/6B	J30/J29	Low Power HCSL differential output
9	DIP Switch	U2	S1: Output Enable (OE/SD) S2: Sel0 S3: Sel1 S4: Output Enable Buffer (OE_BUFFER) S5: Output Enable Buffer (for outputs 3 and 5) S6: Output Enable Buffer (for outputs 6 and 7) S8: Sel [1:0] ; Default: I ² C mode
10	USB Interface	J18	Used for connection with a PC and for interaction with the IDT Timing Commander Software.
11	Output 1/1B	J20/J19	Can be differential pair output or two individual single ended outputs
12	Output 2/2B	J22/J21	Can be differential pair output or two individual single ended outputs
13	Output Voltage Power Supply Selector	<i>OUT0_SELB_I2C</i> :JP2 <i>OUT1</i> :JP4 <i>OUT2</i> :JP6 <i>OUT4</i> :JP8	4-way header to select a power supply method for outputs 0,1,2 and 4. The center pin is the output voltage. Use jumper J15 to select a 1.8V, 2.5V or 3.3V supply. VDDO_J_OUT0/1/2/4 is the voltage from J15
14	Output 3/3B	J26/J25	Low Power HCSL differential output
15	Ground Jack	J17	Used for grounding. If J15 and/or J16 is used for power supply, this jack functions as the power return.
16	Output Voltage Jack	J33	Low power HCSL voltage jack that provides 1.8V supply
17	Output Voltage Power Supply Selector	JP7	3-way header to select a power supply of 1.8V through regulator supply or the output voltage from J33 to the LP-HCSL outputs 3, 5 - 7 outputs for the 5P49V5907 and output 3, 5-11 for the 5P49V5908. The center pin is the output voltage. VDDO_LP_HCSL is the voltage from J33
18	Output 4/4B	J24/J23	Low Power HCSL differential output
19	Output 5/5B	J28/J27	Low Power HCSL differential output
20	Output Voltage Jack	J15	Connect to 1.8V, 2.5V or 3.3V to provide output voltage supply

In addition to the 5P49V5907 pinouts, 5P49V5908 has the following four outputs (refer to [Table 2](#) below):

Table 2: 5P49V5908 Extra Outputs

Item	Name	On-Board Connector Label	Function
21	Output 8/8B	J34/J33	Low Power HCSL differential output
22	Output 9/9B	J36/J35	Low Power HCSL differential output
23	Output 10/10B	J38/J37	Low Power HCSL differential output
24	Output 11/11B	J40/J39	Low Power HCSL differential output

Board Power Supply

Power Supply Options

Bench Power Supply – An external power supply can be used to supply a 1.8V supply. To supply VDDA_1 with a bench power supply, connect power to J16. Concurrently, place the jumpers in JP3 to connect VDDA_1 to VDDD_J.

USB Power Supply – When the board is connected to a PC through a USB cable, on-board voltage regulators will generate a 3.3V for the device. In this case, place the jumpers in JP3 to connect VDDA_1 to VDDA/D. See JP3 jumper position for VDDA/D in the [Figure 2](#). USB power source is recommended for ease of use.

Figure 2. Selecting the VDDA/D side will select power source from on-board regulators powered by USB; Selecting the VDDD_J side will select external bench power supply



Output Clock Voltages

Similar to VDDA/D having two sources, each output voltage is also provided with two sources to choose from: Bench power supply or USB power supply connection. The selection is made by a 4-way header as shown in [Figure 3](#) below and a 3-way header as shown in [Figure 4](#). Selection of VDDO_J_OUT0/1/2/4 will enable external power supply (J15 and J16 are connected to external power supply); Selection of 1.8V, 2.5V or 3.3V will enable each on-board voltage regulators powered by USB port.

Figure 3. In the 4-way header, the central pin is the output and the other pins are 1.8V, 2.5V, 3.3V and VDDO_J_OUT 0/1/2/4(from J15) respectively. Jumper settings are selected according to the output voltage required for outputs 0, 1, 2 and 4.

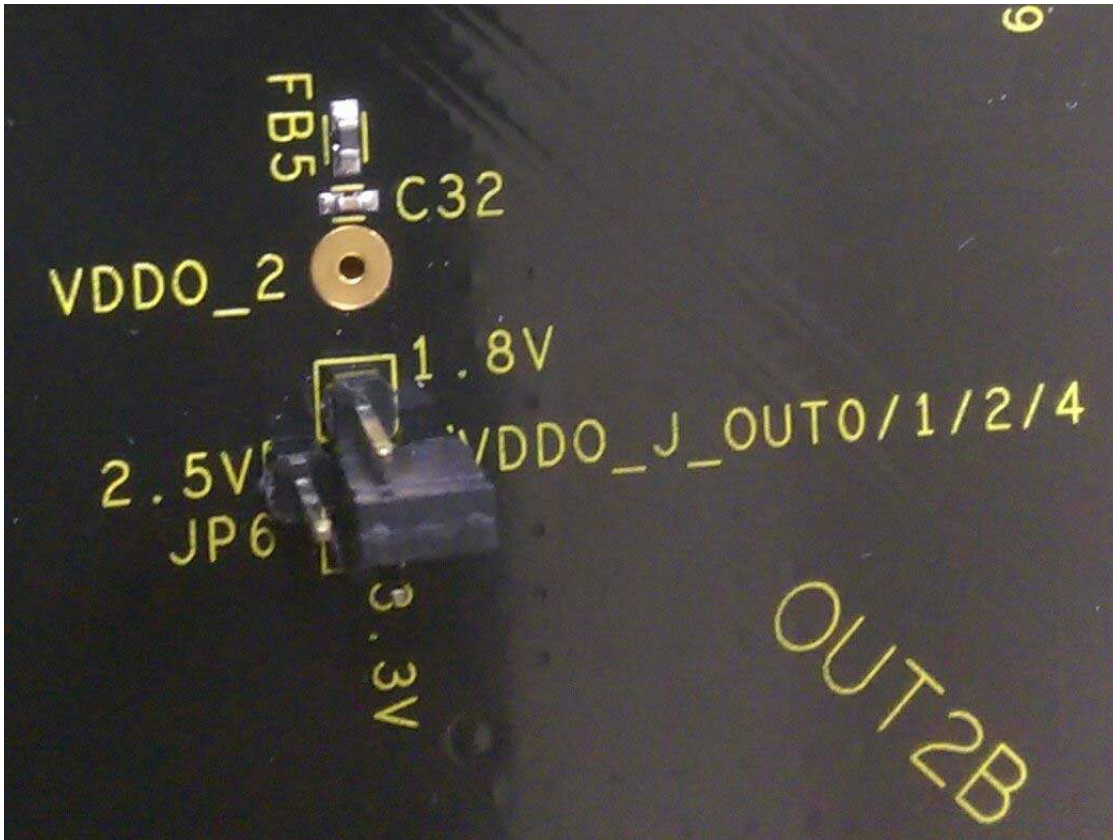

Note: Each output voltage can be individually selected. Use table 3 to select the jumper pin for its respective output:

Table 3: Output Voltage Selection for 5P49V5907/5P49V5908

5P49V5907		5P49V5908	
Pin Label	Output	Pin Label	Output
VDDO_0	OUT0	VDDO_0	OUT0
VDDO_1	OUT1	VDDO_1	OUT1
VDDO_2	OUT2	VDDO_2	OUT2
VDDO_4	OUT4	VDDO_4	OUT4
VDDO_3_5_6_7	OUT3, OUT5, OUT6, OUT7	VDDO_3_5-11	OUT3, OUT5, OUT6, OUT7, OUT8, OUT9, OUT10, OUT11

Figure 4. In the 3-way header, the middle pin is the output node and the 1.8V and VDDO_LP_HCSL on either side. Jumper settings are selected according to the output voltage required for outputs 3, 5, 6 and 7.



Connecting the Board

The board is connected to a PC through a USB connector for configuring and programming the device, as shown in [Figure 5](#) below. The USB interface will also provide +5V power supply to the board, from which on-board voltage regulators generate various voltages for the core as well as for each output.

The board can also be powered by a bench power supply by connecting two banana jacks J15, J16 for output and core voltages, respectively. Please see board power supply section for details.

Note: The USB port only supports USB 2.0; USB 3.0 is not supported at this time.

Figure 5. Connecting 5P49V5907 - EBV USB Port for Communications with Timing Commander Software and input voltage supplies Software

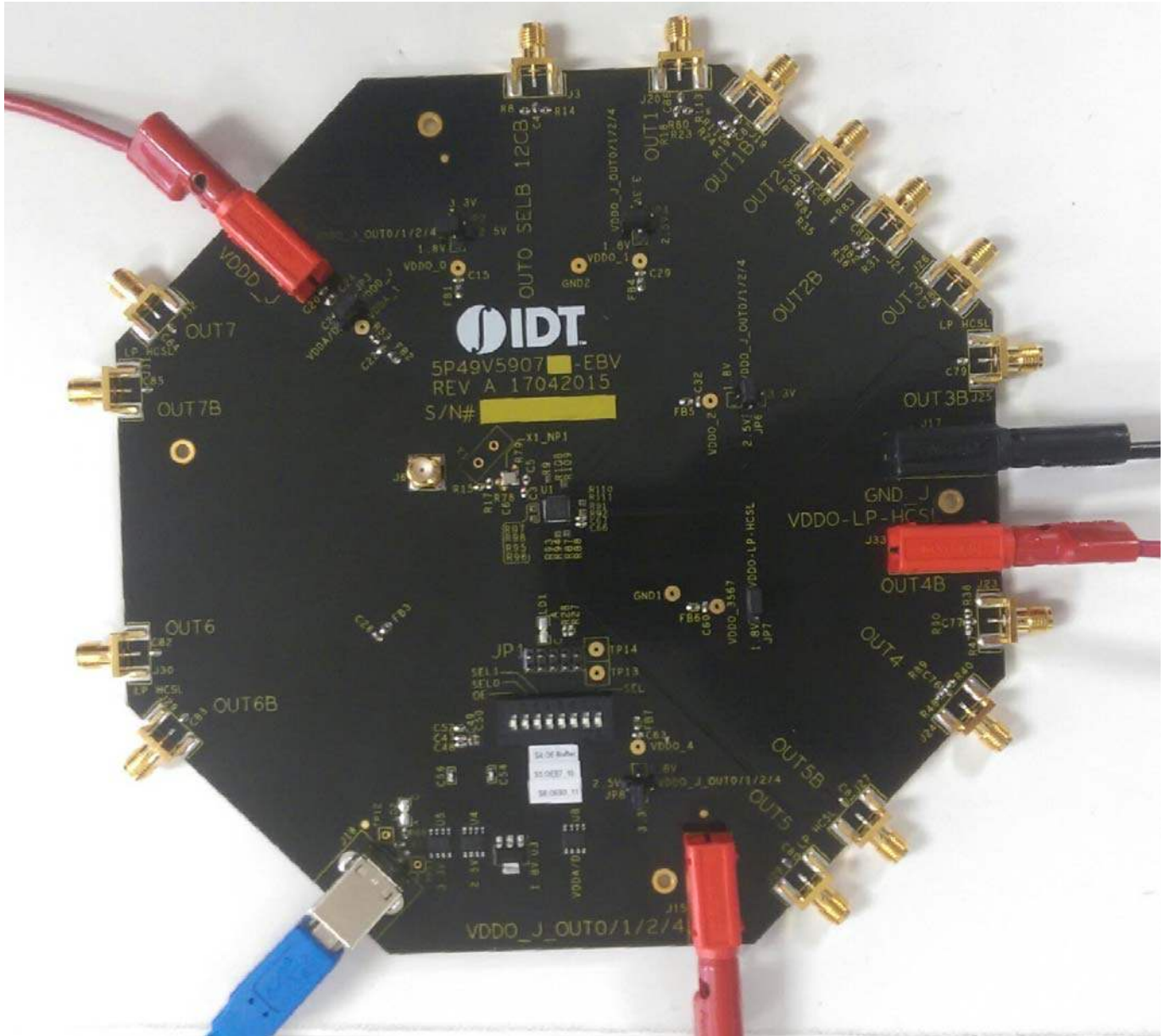

On-Board Crystal

A 25MHz crystal is installed on the board.

Board Default Frequency Output

When 25MHz crystal is installed, the device will have two default outputs: OUT0 = 25MHz, OUT1 = 100MHz.

Configuration and Setup

Use the following steps to setup the board using I²C and start the configuration of the board.

1. Set SEL pin (pin 8) of dip switch (U2) to "0" to select I2C mode.
2. Connect J18 to a USB port of the PC using the supplied I2C cable.
3. Launch VC5 Timing Commander Software (refer to VC5 Timing Commander User Guide - Getting Started Step 1~7)
[Download the VersaClock 5 Timing Commander User Guide Here](#)
4. Following the Getting Started steps in the Timing Commander software, an I2C connection is established between the GUI software and the VersaClock 5 chip.
5. Select "Open Settings File" if you have existing settings or "New Settings File" and select 5P49V5907 or 5P49V5908 depending on your evaluation board. In the same screen, browse for a personality file, by clicking on the button at the bottom right, to be used with the evaluation board.
6. Connect to the EVB by clicking on the microchip icon located at the top right of the Timing Commander.



7. Once connected, new options will be available on a green background indicating that the EVB has successfully connected with the board. Write the settings to the chip by clicking on the write all registers to the chip option.



8. All intended outputs should now be available for measurement.

Board Schematics

Evaluation board schematics are shown on the following pages.

Figure 6. 5P49V5907 VersaClock 5 Evaluation Board Schematics – Page 1

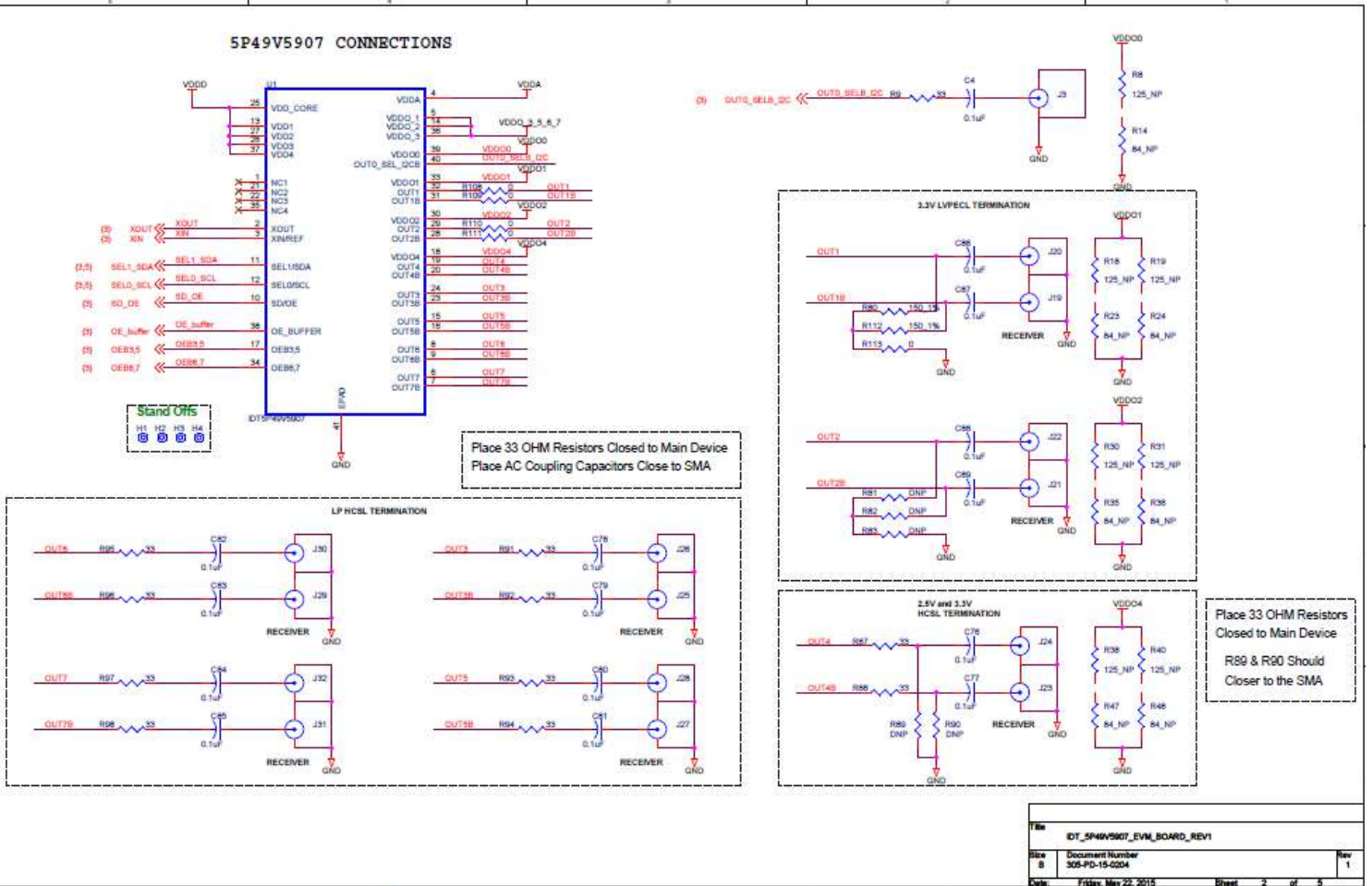

Figure 7. 5P49V5907 VersaClock 5 Evaluation Board Schematics – Page 2

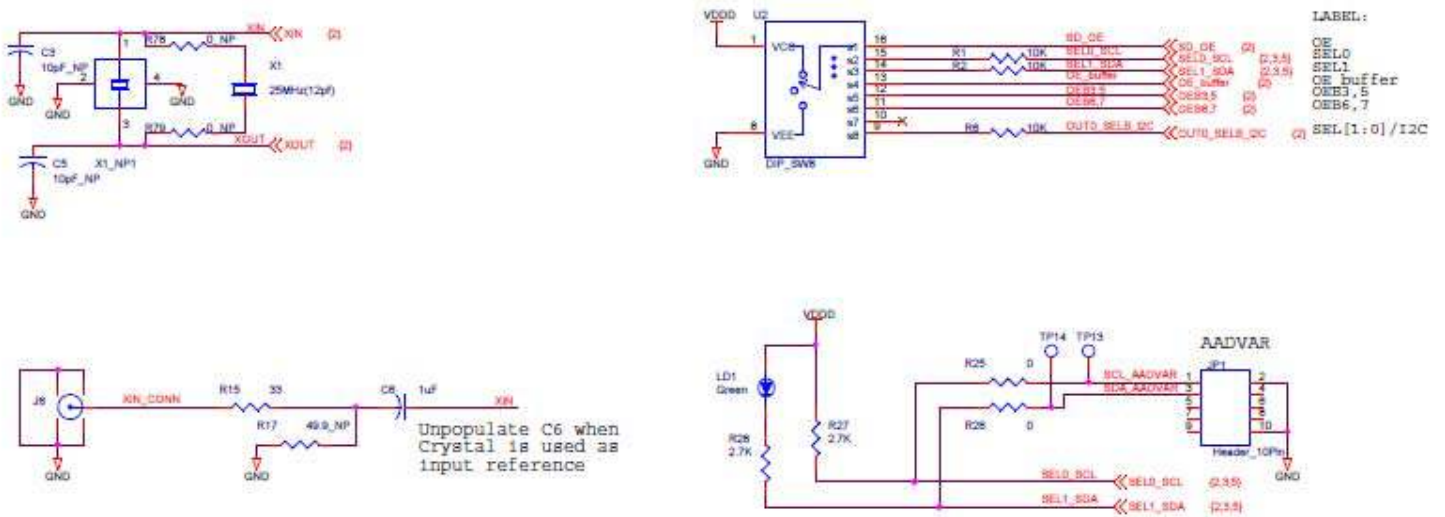

Figure 8. 5P49V5907 Evaluation Board Schematics – Page 3

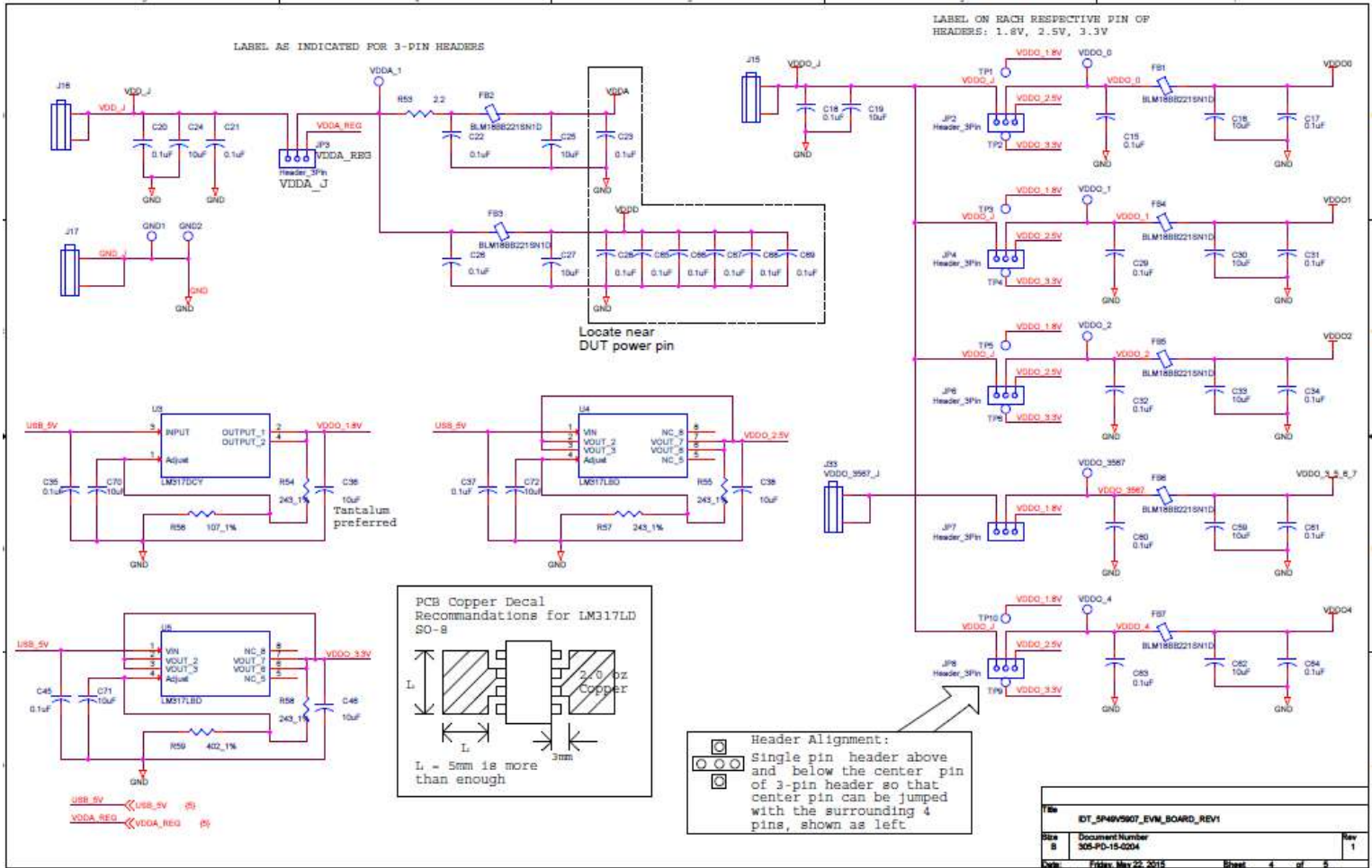

Figure 12. 5P49V5908 Evaluation Board Schematics – Page 3

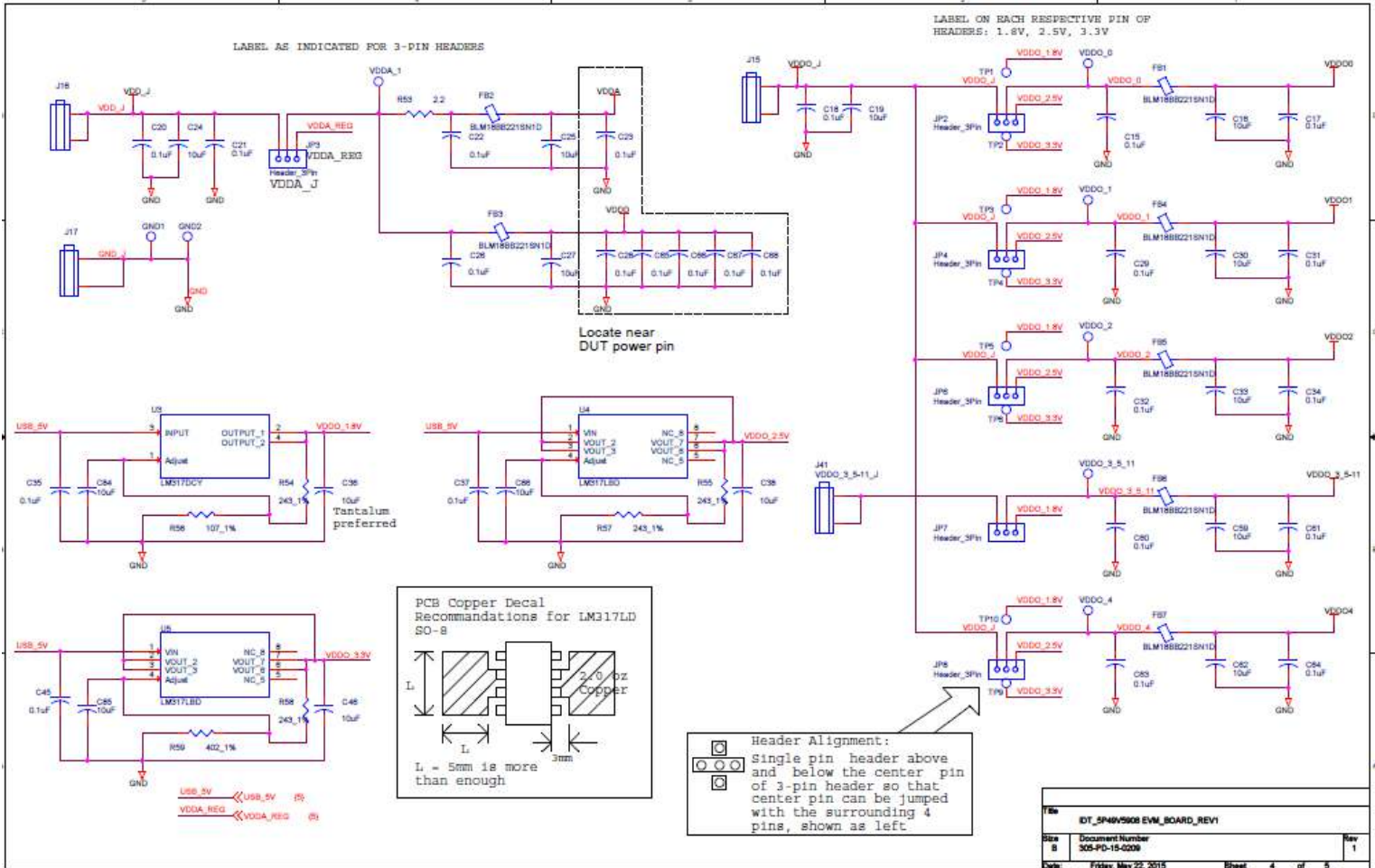
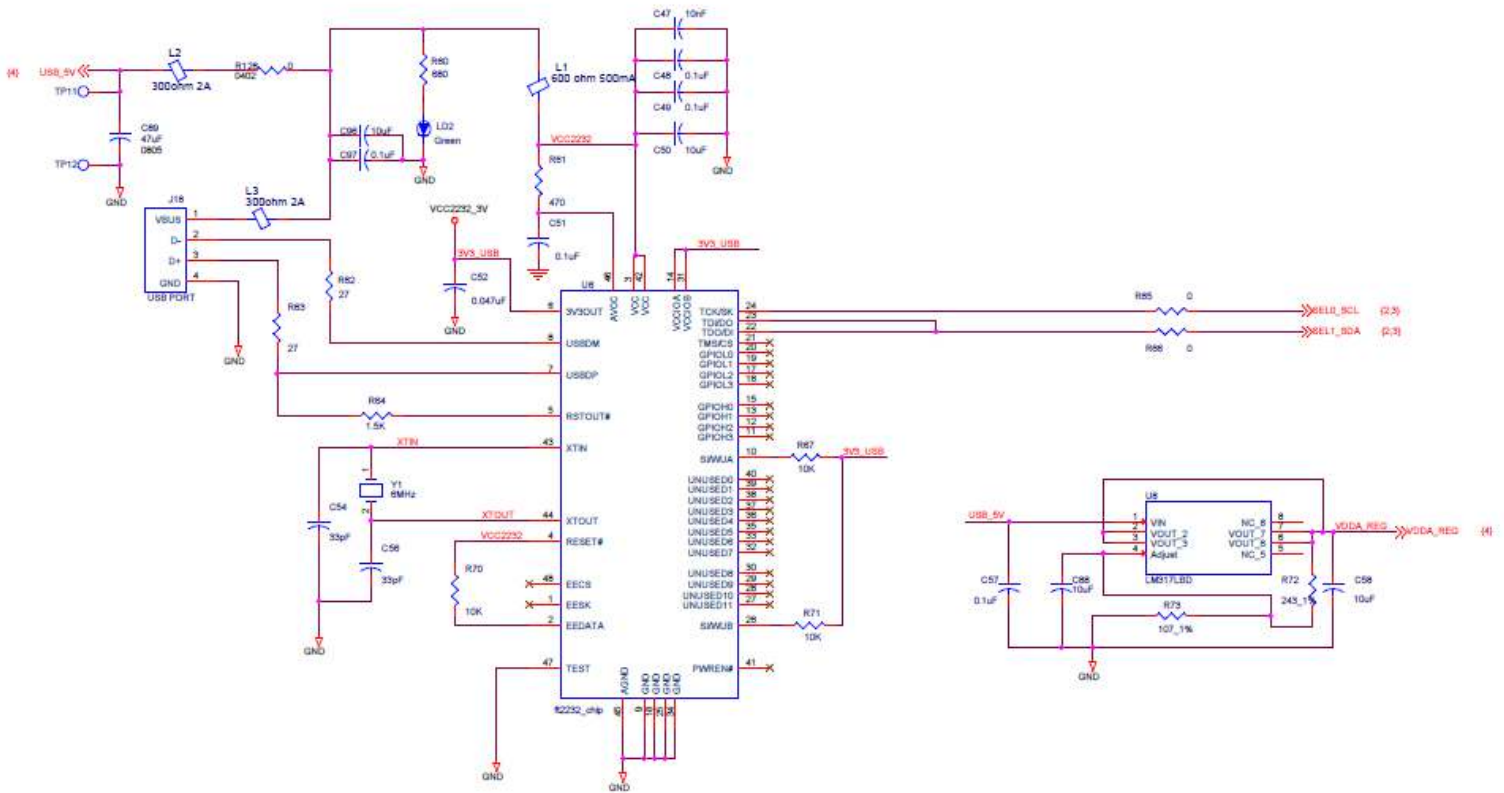

Figure 13. 5P49V5908 Evaluation Board Schematics – Page 4



Signal Termination Options

Termination options for OUTPUT 1 - 7 for the 5P49V5907 EBV board are displayed in Figure 14 and termination options for OUTPUT 1 - 7 for the 5P49V5908 EBV board are displayed in Figure 15 and Figure 16. The termination circuits are designed to optionally terminate the output clocks in LVPECL, LVDS, LVCMOS and LP-HCSL signal types by populating (or not-populating) some resistors. Default termination configurations which are pre-installed on the EVB are indicated in the tables. DC or AC coupling of these outputs are also supported.

Table 4 – 7, tabulate component installations to support LVPECL, LP-HCSL, LVCMOS and LVDS signal types for OUTPUT1- 7 on the 5P49V5907 EBV and Table 8 – 11, tabulate component installations to support LVPECL, LP-HCSL, LVCMOS and LVDS signal types for OUTPUT1- 11 on the 5P49V5908 EBV, respectively. Please note that by doing so, the output signals will be measured and terminated by an oscilloscope with a 50Ω internal termination.

Figure 14. 5P49V5907 Output Termination Options

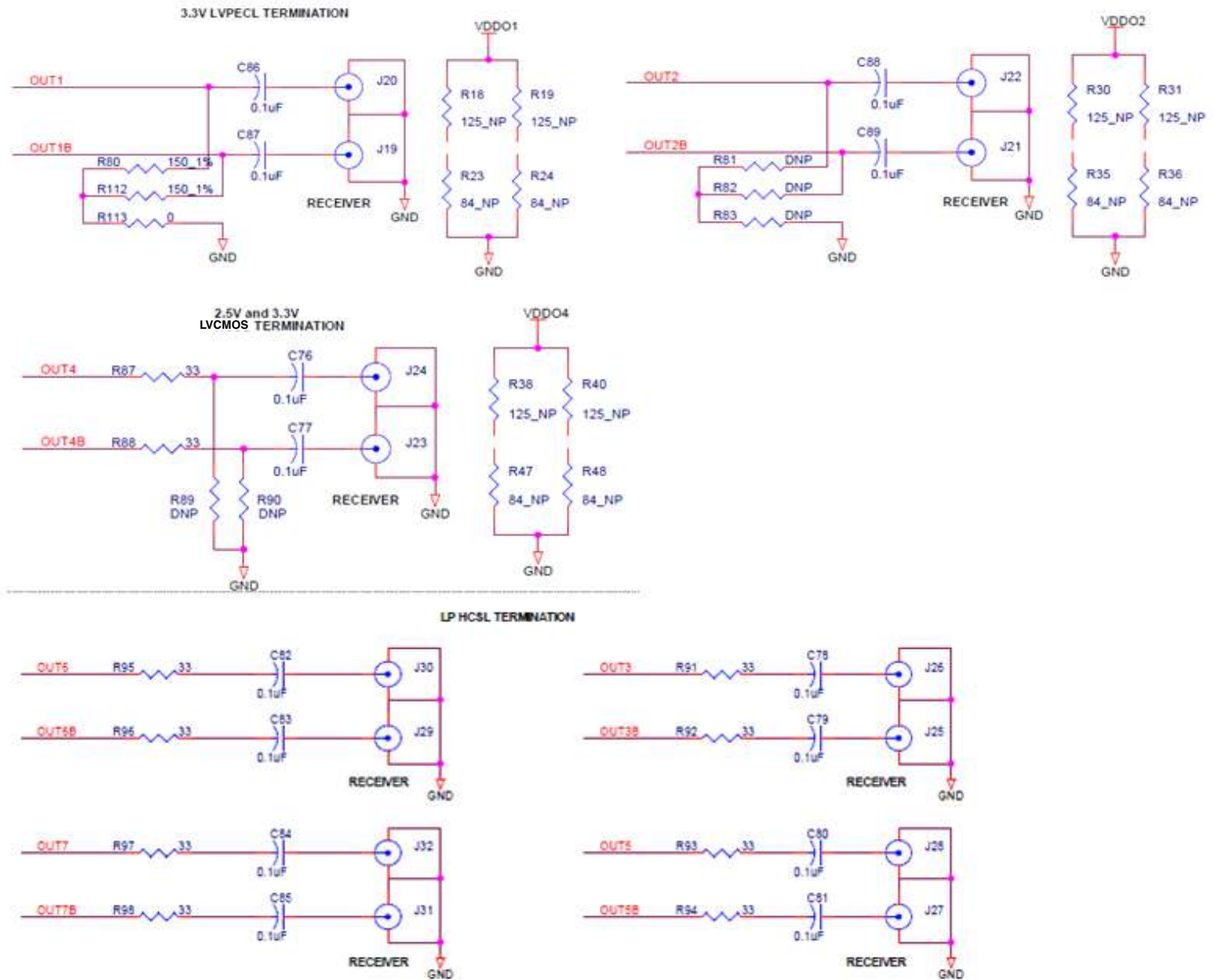

Termination Options for 5P49V5907

Table 4: Termination Configuration for OUTPUT1

Signal Type	Series Resistors: R108,R109	Pull-down Resistors: R80, R112, R113	Series Capacitor: C86, C87	Resistor Network: R18, R19, R23, R24
LVPECL*	0 Ω	R80=R112=150 Ω , R113=0 Ω ,	0.1 μ F	Not installed

Table 5: Termination Configuration for OUTPUT2

Signal Type	Series Resistors: R110,R111	150-ohm pull-down: R81, R82, R83	Series Capacitor: C88, C89	Resistor Network: R30, R31, R35, R36
LVDS*	0 Ω	Not installed	0.1 μ F	Not installed

Table 6: Termination Configuration for OUTPUT3, 5–7

Signal Type	Series Resistors: R91,R92; R93,R94; R95,R96; R97,R98	150-ohm pull-down: R21, R22	Series Capacitor: C78,C79; C80,C81; C82,C83; C84,C85	Resistor Network: R41, R42, R51, R52
LPHCSL*	33 Ω	Not Installed	0.1 μ F	Not installed

Table 7: Termination Configuration for OUTPUT4

Signal Type	Series Resistors: R87, R88	150-ohm pull-down: R89, R90	Series Capacitor: C76, C77	Resistor Network: R38, R40, R47, R48
LVC MOS*	33 Ω	Not installed	0.1 μ F	Not installed
LVDS	Not Installed	Not installed	0.1 μ F	Not installed

As noted, 4-resistor network is not installed in Table 4–7 because oscilloscope with internal 50 Ω termination is utilized for signal termination and measurement. If an AC-coupled, stand-alone LVPECL output is needed (without oscilloscope connections), the 4-resistor network needs to be installed accordingly.

* This signal type is the default configuration for the evaluation board. Contact IDT if user wants to change termination configurations to support other output signal types.

Figure 15. 5P49V5908 Output Termination Options (a)

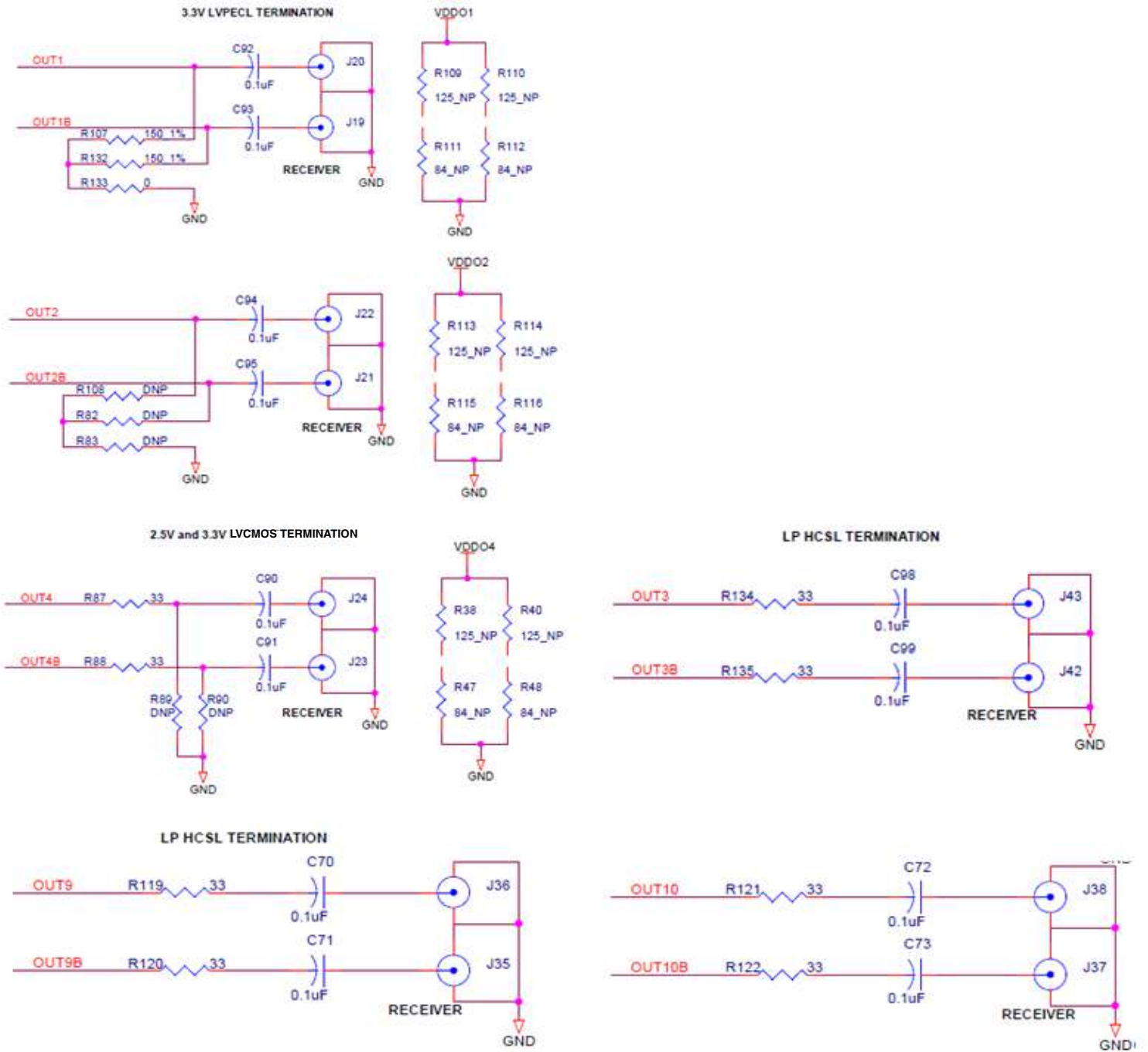

Note: For 2.5V and 3.3V HCSL termination, the C90 and C91 positions need to be assembled with 0 Ω resistors.

Figure 16. 5P49V5908 Output Termination Options (b)

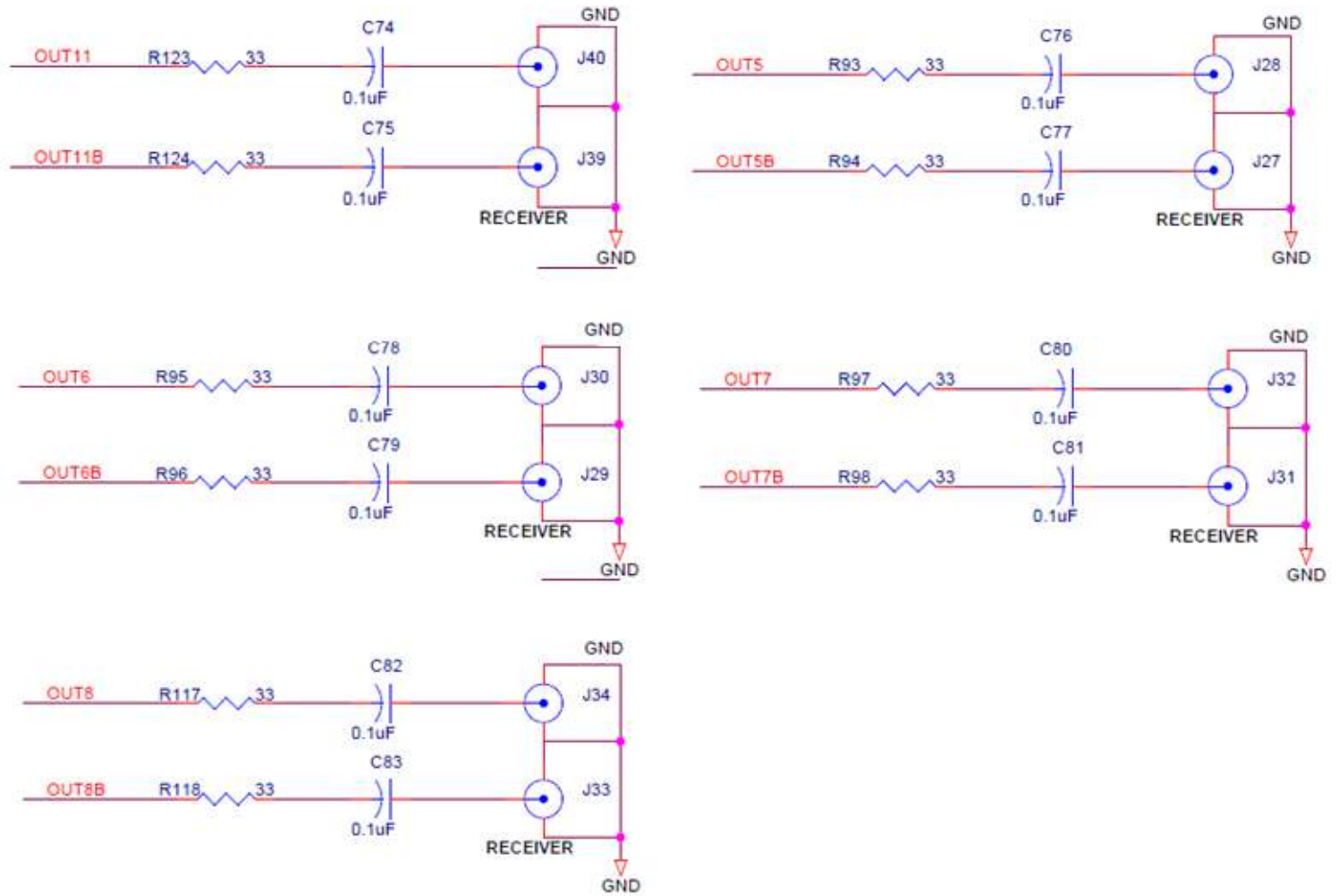

Termination Options for 5P49V5908

Table 8: Termination Configuration for OUTPUT1

Signal Type	Series Resistors: R127,R128	Pull-down Resistors: R107, R132, R133	Series Capacitor: C92, C93	Resistor Network: R109, R110, R111, R112
LVPECL*	0 Ω	R107=R132=150 Ω, R133=0 Ω	0.1 μF	Not installed

Table 9: Termination Configuration for OUTPUT2

Signal Type	Series Resistors: R129,R130	Pull-down Resistors: R108, R82, R83	Series Capacitor: C94, C95	Resistor Network: R113, R114, R115, R116
LVDS*	0 Ω	Not installed	0.1 μF	Not installed

Table 10: Termination Configuration for OUTPUT3, 5–11

Signal Type	Series Resistors: R134, R135; R93, R94; R95, R96; R97, R98; R117, R118; R119, R120; R121, R122; R123, R124;	150-ohm pull-down: R21, R22	Series Capacitor: C12, C14	Resistor Network: R41, R42, R51, R52
LPHCSL*	33 Ω	Installed	0.1 μF	Not installed

Table 11: Termination Configuration for OUTPUT4

Signal Type	Series Resistors: R87, R88	150-ohm pull-down: R89, R90	Series Capacitor: C90, C91	Resistor Network: R38, R40, R47, R48
LVC MOS*	33 Ω	Not installed	0.1 μF	Not installed

As noted, 4-resistor network is not installed in Table 8–11 because oscilloscope with internal 50Ω termination is utilized for signal termination and measurement. If an AC-coupled, stand-alone LVPECL output is needed (without oscilloscope connections), the 4-resistor network needs to be installed accordingly.

* This signal type is the default configuration for the evaluation board. Contact IDT if user wants to change termination configurations to support other output signal types.

Orderable Part Numbers

The following evaluation board part numbers are available for order.

Table 12: Orderable Part Numbers

Part Number	Description
EVKVC5-5907ALL	5P49V5907 Evaluation board with one output of each type of signal termination.
EVKVC5-5908ALL	5P49V5908 Evaluation board with one output of each type of signal termination.

IMPORTANT NOTICE AND DISCLAIMER

RENESAS ELECTRONICS CORPORATION AND ITS SUBSIDIARIES (“RENESAS”) PROVIDES TECHNICAL SPECIFICATIONS AND RELIABILITY DATA (INCLUDING DATASHEETS), DESIGN RESOURCES (INCLUDING REFERENCE DESIGNS), APPLICATION OR OTHER DESIGN ADVICE, WEB TOOLS, SAFETY INFORMATION, AND OTHER RESOURCES “AS IS” AND WITH ALL FAULTS, AND DISCLAIMS ALL WARRANTIES, EXPRESS OR IMPLIED, INCLUDING, WITHOUT LIMITATION, ANY IMPLIED WARRANTIES OF MERCHANTABILITY, FITNESS FOR A PARTICULAR PURPOSE, OR NON-INFRINGEMENT OF THIRD PARTY INTELLECTUAL PROPERTY RIGHTS.

These resources are intended for developers skilled in the art designing with Renesas products. You are solely responsible for (1) selecting the appropriate products for your application, (2) designing, validating, and testing your application, and (3) ensuring your application meets applicable standards, and any other safety, security, or other requirements. These resources are subject to change without notice. Renesas grants you permission to use these resources only for development of an application that uses Renesas products. Other reproduction or use of these resources is strictly prohibited. No license is granted to any other Renesas intellectual property or to any third party intellectual property. Renesas disclaims responsibility for, and you will fully indemnify Renesas and its representatives against, any claims, damages, costs, losses, or liabilities arising out of your use of these resources. Renesas' products are provided only subject to Renesas' Terms and Conditions of Sale or other applicable terms agreed to in writing. No use of any Renesas resources expands or otherwise alters any applicable warranties or warranty disclaimers for these products.

(Disclaimer Rev.1.0 Mar 2020)

Corporate Headquarters

TOYOSU FORESIA, 3-2-24 Toyosu,
Koto-ku, Tokyo 135-0061, Japan
www.renesas.com

Contact Information

For further information on a product, technology, the most up-to-date version of a document, or your nearest sales office, please visit:
www.renesas.com/contact/

Trademarks

Renesas and the Renesas logo are trademarks of Renesas Electronics Corporation. All trademarks and registered trademarks are the property of their respective owners.