

REVISONS		DATE	BY	APPROVED
E	REVISED PER ECO-17-018523	19JAN2018	PHM	CT

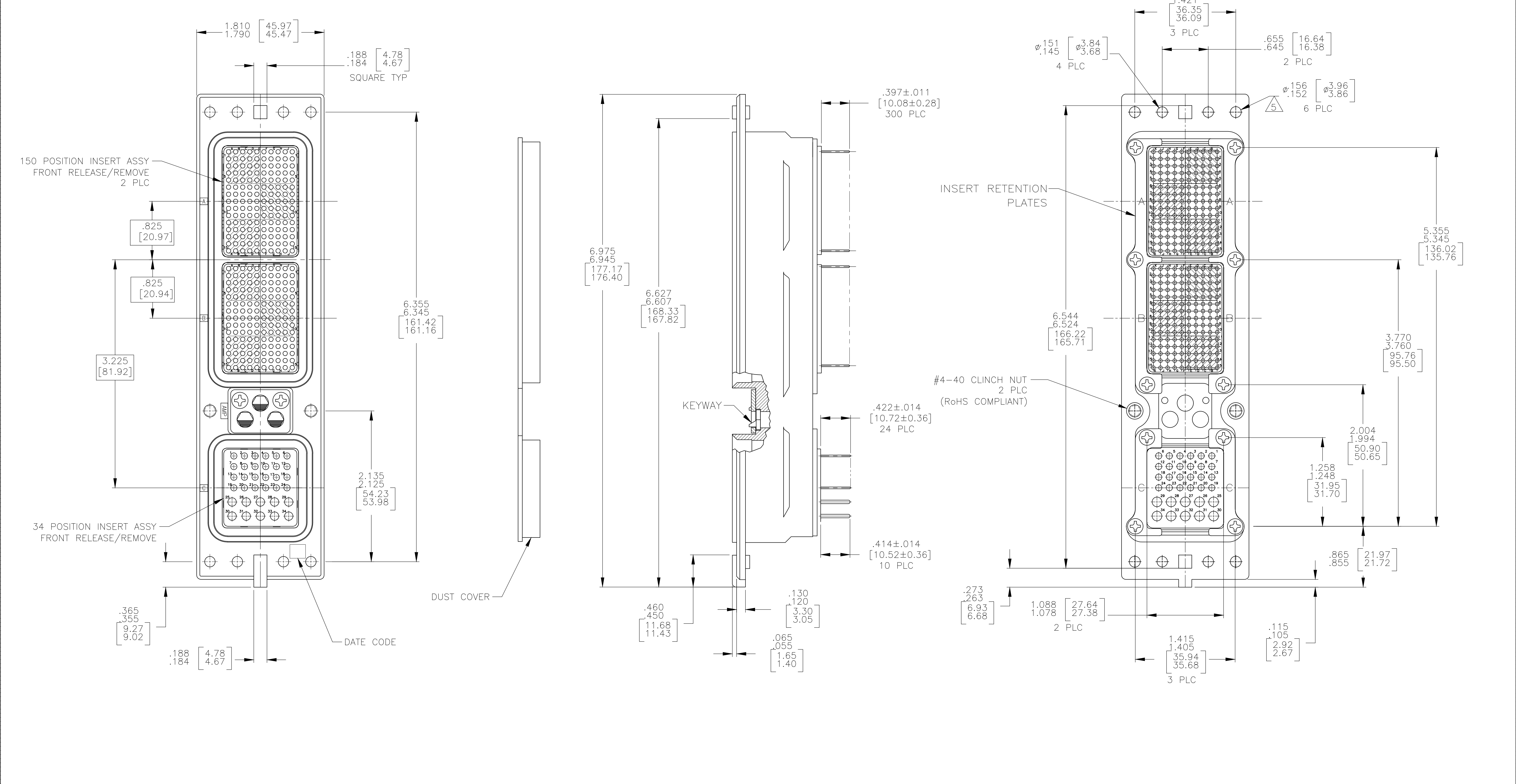

- CONNECTOR DIMENSIONS ARE PER ARINC 600 SPECIFICATION
 - DUST COVER INSTALLED FOR SHIPPING.
 - KEYING SHOWN IN POSITION "01" FOR REFERENCE ONLY. SEE TABLE FOR KEYING POSITION. FOR POSITION "00" KEYING SHIPPED UNASSEMBLED.
 - CONTACTS NOT SHOWN IN FRONT AND REAR VIEWS FOR CLARITY.
- 5 TWO OF THE SIX .154 NOMINAL HOLES HAVE #4-40 CLINCH NUTS INSTALLED.

COMPONENT	MATERIAL	FINISH
SHELL	DIE CAST ALUMINUM PER ASTM-B-85	CHROMATE CONVERSION PER MIL-C-5541, TYPE II, CLASS 3
INSERT RETENTION PLATES	ALUMINUM ALLOY PER ASTM-B-209	CHROMATE CONVERSION PER MIL-C-5541, TYPE II, CLASS 3
SCREWS	STEEL OR STAINLESS STEEL	STAINLESS STEEL OR PASSIVATED
POLARIZING KEYS	ZINC ALLOY PER ASTM-B-86	-
POLARIZING KEY RETAINING PLATE	ALUMINUM ALLOY PER ASTM-B-209	BLUE ANODIZED PER MIL-A-8625
INSERTS	THERMOSET OR THERMOPLASTIC PPS PER MIL-M-24519	-
DUST COVER	CONDUCTIVE THERMOPLASTIC	-

"01"	MODULE A 211431-6 (SZ 22 POSTED SOCKET CONTACT; QTY=150)	2157235-1
	MODULE B 211431-6 (SZ 22 POSTED SOCKET CONTACT; QTY=150)	
KEYING POSITION	MODULE C 2-448138-6 (SZ 20 POSTED PIN CONTACT; QTY=24)	CONTACTS INCLUDED AND INSTALLED
	448139-6 (SZ 16 POSTED PIN CONTACT; QTY=10)	

THIS DRAWING IS A CONTROLLED DOCUMENT.		DIN C.C.THOMAS 1-11-11	TE Connectivity
DIMENSIONS: INCHES		CHK K.THACKSTON 1-11-11	
TOLERANCES UNLESS OTHERWISE SPECIFIED:		APVD K.THACKSTON 1-11-11	NAME
0 PLC ± -	1 PLC ± -	PRODUCT SPEC	RCPT ASSY, SIZE 2, ARINC 600 (150/150/34), FR
2 PLC ± -	3 PLC ± -	APPLICATION SPEC	SIZE
4 PLC ± -	ANGLES ± -	WEIGHT	CAGE CODE
MATERIAL SEE TABLE	FINISH SEE TABLE	CUSTOMER DRAWING	DRAWING NO A100779
		SCALE	RESTRICTED TO
		3:2	1 OF 1