

"Mini" SiSonic™ Microphone Specification  
With Enhanced RF Protection - *Halogen Free*

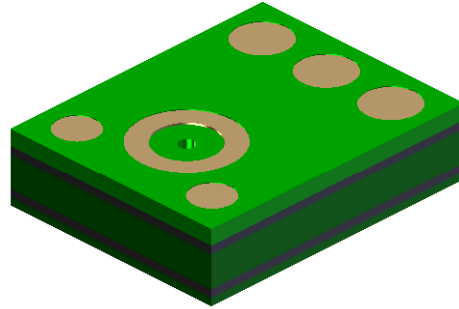
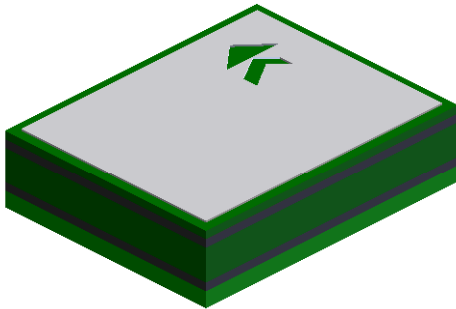

**Knowles Acoustics**  
1151 Maplewood Drive  
Itasca, IL 60143

## 1. DESCRIPTION AND APPLICATION

### 1.1 DESCRIPTION

"Mini" Surface Mount Silicon Microphone with  
Enhanced RF Protection - *Halogen Free*

### 1.2 APPLICATION

Consumer electronics devices

## 2. PART MARKING

Identification Number Convention

S 1 2 3

4 5 6 7

S: Manufacturing Location

"S" - Knowles Electronics Suzhou  
Suzhou, China

"No Alpha Character" - Knowles Electronics  
Itasca, IL USA

"E" - Engineering Samples

Digits 1-7: Job Identification Number

## 3. TEMPERATURE RANGE

3.1 Operating Temperature Range: -40°C to +100°C

3.2 Storage Temperature Range: -40°C to +100°C

#### 4. ACOUSTIC & ELECTRICAL SPECIFICATIONS

TEST CONDITIONS: +20 °C, 60-70% R.H.

	Symbol	Condition	Limits			Unit
			Min.	Nom.	Max.	
Directivity		Omni-directional	—	—	—	
Sensitivity	S	@ 1kHz (0dB-1V/Pa)	-41	-38	-35	dB
Output Impedance	Z <sub>OUT</sub>	@ 1kHz (0dB-1V/Pa)	—	—	300	Ω
Current Consumption	I <sub>DDs</sub>	Across 1.5 to 3.6 volts	—	—	250	μA
Signal to Noise Ratio	S/N	@ 1kHz (0dB-1V/Pa)	—	62	—	dB
Supply Voltage	V <sub>s</sub>		1.5	—	3.6	V
Sensitivity Loss Across Voltage		Change in sensitivity over 3.6V to 1.5V	No Change Across Voltage Range			dB
Total Harmonic Distortion	THD	At 100dB SPL, THD < 1% At 115dB SPL, THD ≤ 10%				

#### 5. FREQUENCY RESPONSE CURVE

**TYPICAL FREE FIELD RESPONSE  
NORMALIZED TO 1kHz**

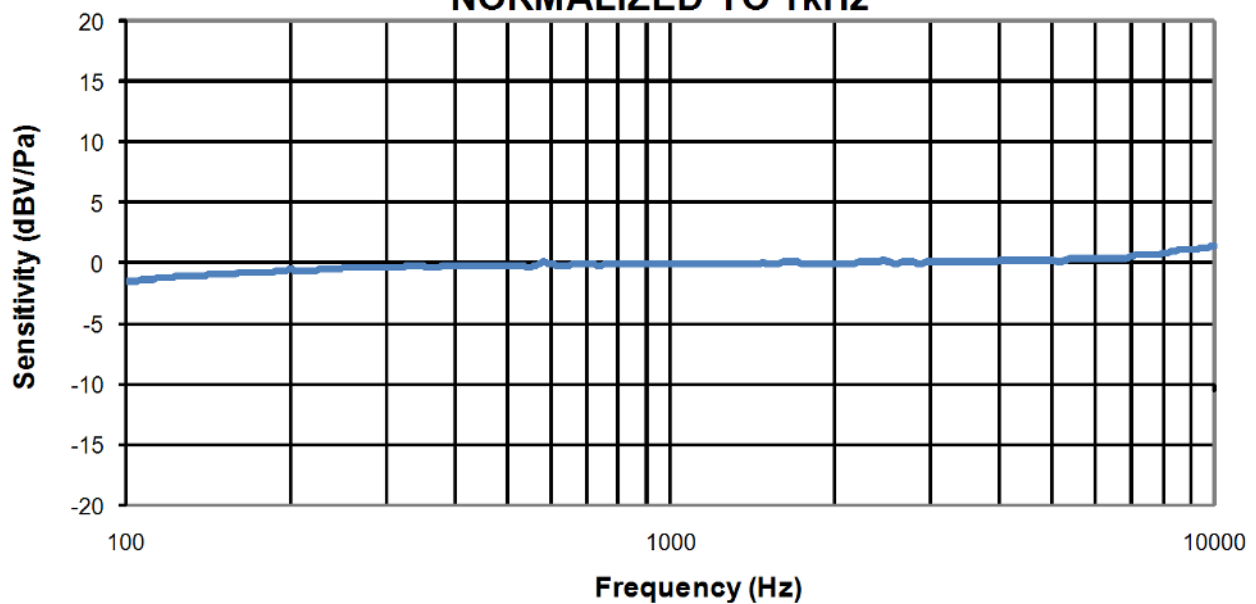

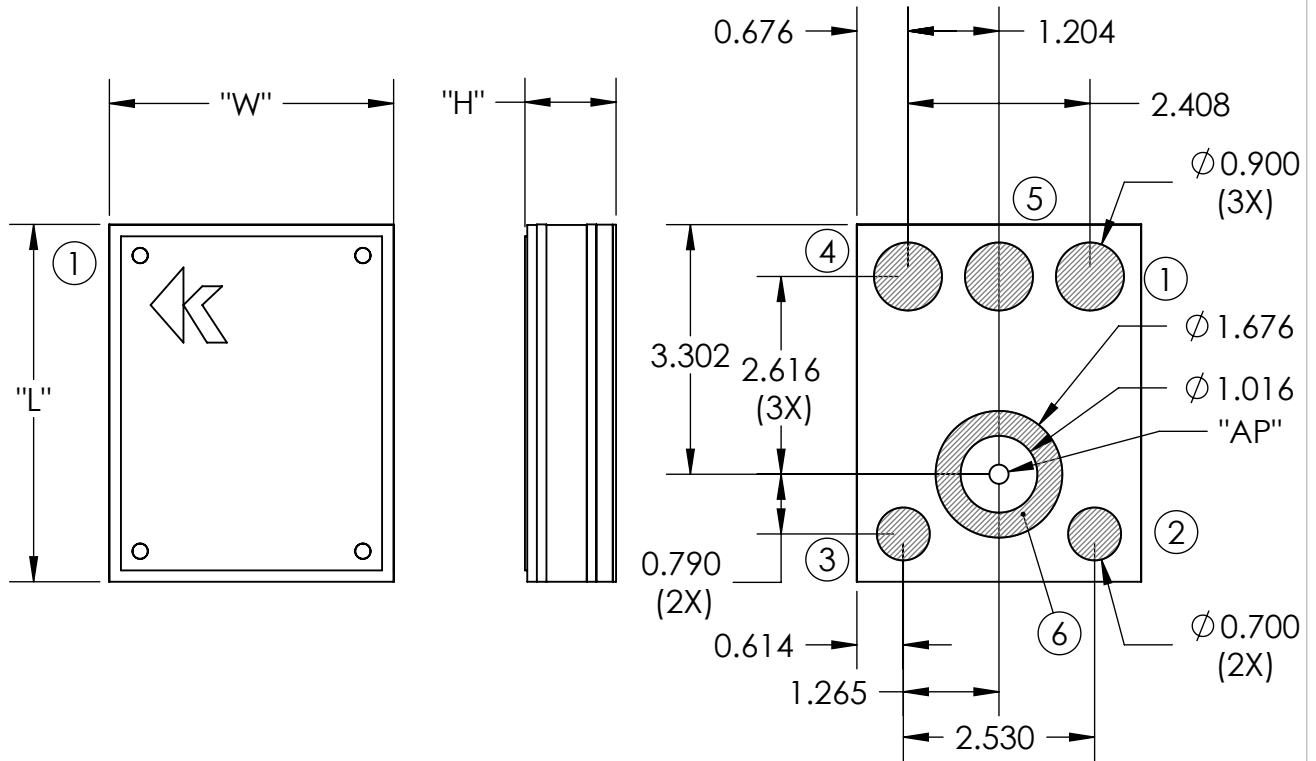
**6. MECHANICAL SPECIFICATIONS**

ITEM	DIMENSION	TOLERANCE	UNITS
LENGTH (L)	4.724	±0.100	mm
WIDTH (W)	3.759	±0.100	mm
HEIGHT (H)	1.250	±0.100	mm
ACOUSTIC PORT (AP)	Ø0.254	±0.100	mm

PIN OUTPUT	
PIN #	FUNCTION
1	OUTPUT
2	GROUND
3	GROUND
4	POWER (Vdd)
5	GROUND
6	GROUND

**Note:**

**Dimensions are in millimeters unless otherwise specified.**

**Tolerance ±0.15mm unless otherwise specified.**

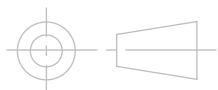

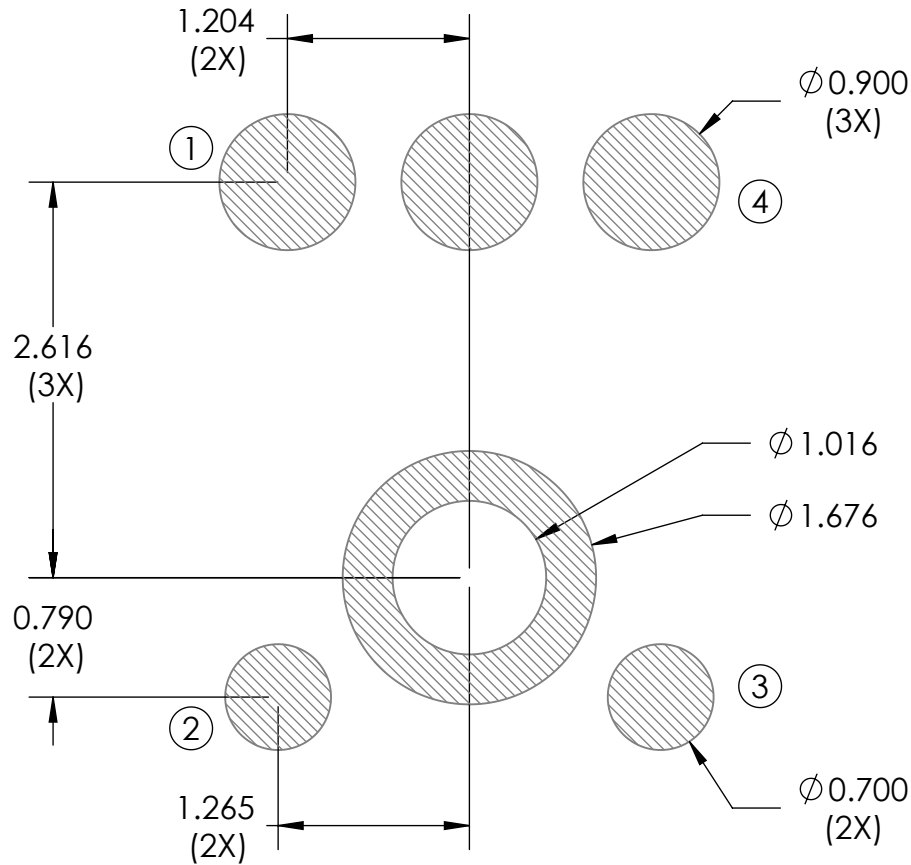
**7. RECOMMENDED CUSTOMER LAND PATTERN**

**8. RECOMMENDED SOLDER STENCIL PATTERN**

N/A

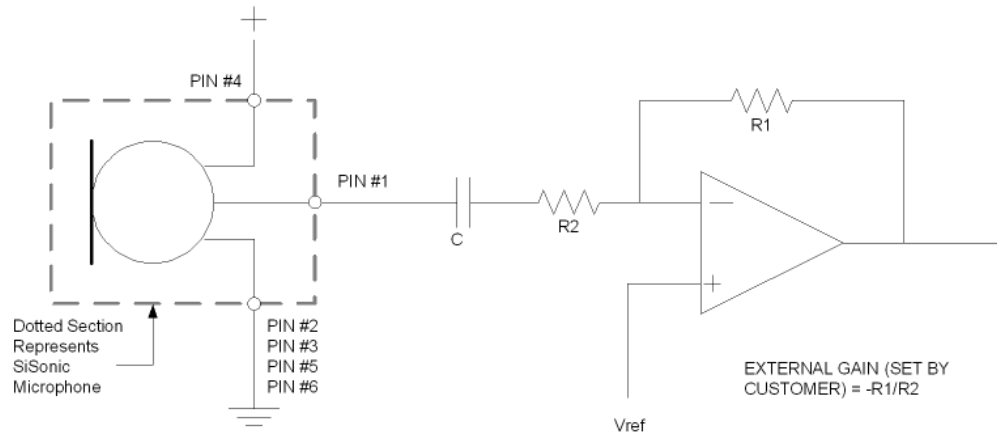
## 9. RECOMMENDED INTERFACE CIRCUIT

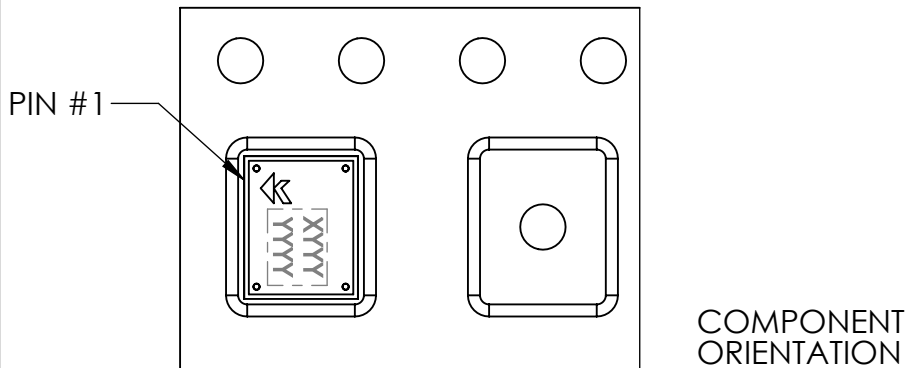
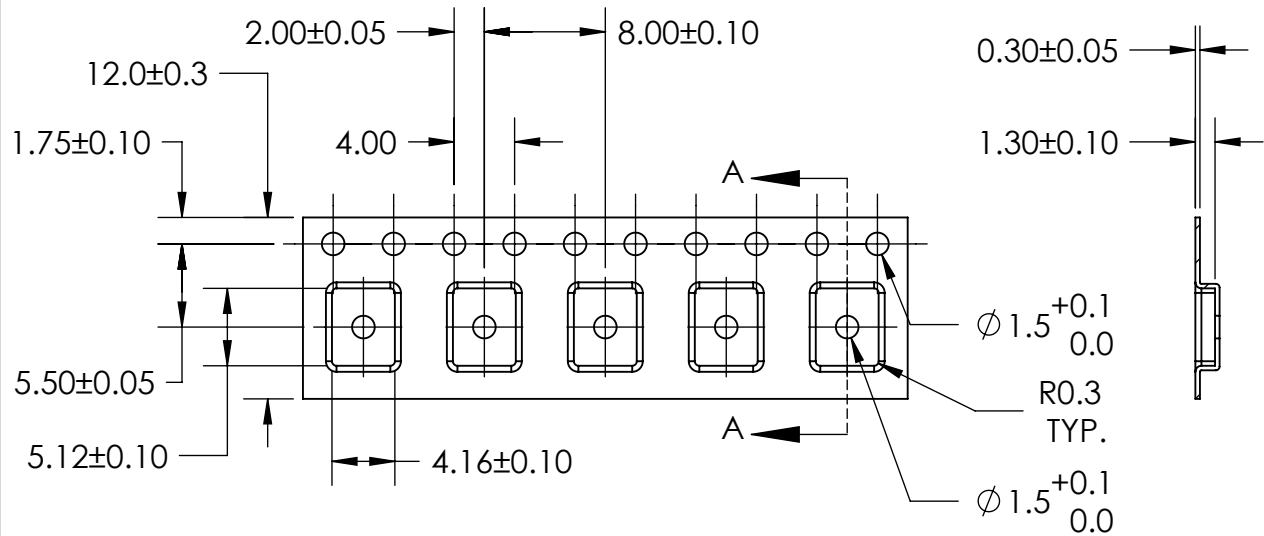

**10. PACKAGING DETAIL**

MODEL NUMBER	SUFFIX	REEL DIAMETER	QUANTITY PER REEL
SPM0404LE5H-QB	-2	7"	1,200
	-6	13"	4,800

TAPE & REEL	PER EIA-481
LABEL	LABEL APPLIED TO EXTERNAL PACKAGE & DIRECT TO REEL.

**Note:**

**Dimensions are in millimeters unless otherwise specified.**

## 11. SOLDER FLOW PROFILE

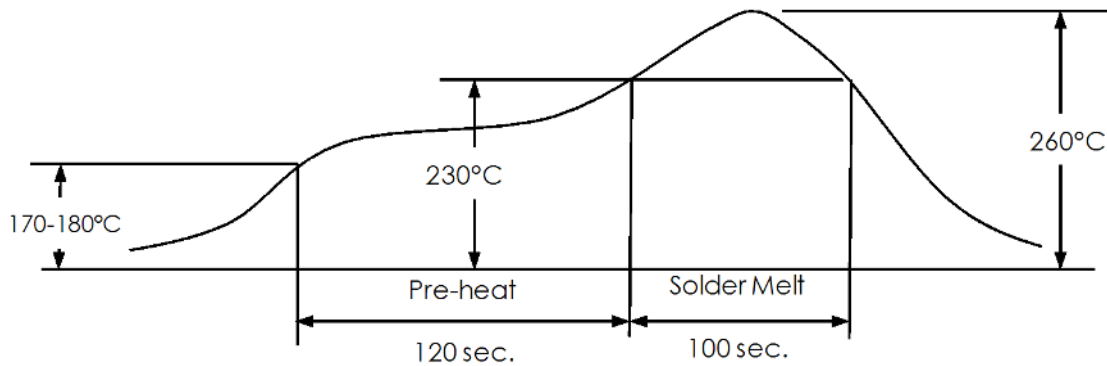

Stage	Temperature Profile	Time (maximim)
Pre-heat	170 ~ 180°C	120 sec.
Solder Melt	Above 230°C	100 sec.
Peak	260°C maximum	30 sec.

## 12. ADDITIONAL NOTES

- (A) Shelf life: Twelve (12) months when devices are to be stored in factory supplied, unopened ESD moisture sensitive bag under maximum environmental conditions of 30°C, 70% R.H.
- (B) MSL (moisture sensitivity level) Class 2a.
- (C) Do not pull a vacuum over port hole of the microphone. Pulling a vacuum over the port hole can damage the device.
- (D) Do not board wash after the reflow process. Board washing and cleaning agents can damage the device. Do not expose to ultrasonic processing or cleaning.
- (E) Do not brush board after the reflow process. Brushing the board with/without solvents can damage the device.
- (F) Do not insert any object in port hole of device at any time as this can damage the device.
- (G) Number of reflow - Recommend no more than 3 cycles.



### 13. RELIABILITY SPECIFICATIONS

**Note:** After test conditions are performed, the sensitivity of the microphone shall not deviate more than 3dB from its initial value.

Test	Description
Thermal Shock	100 cycles of air-air thermal shock from -40°C to +125°C with 15 minute soaks. (ICE 68-2-4)
High Temperature Storage	+105°C environment for 1,000 hours. (ICE 68-2-2 Test Ba)
Low Temperature Storage	-40°C environment for 1,000 hours. (ICE 68-2-2 Test Aa)
High Temperature Bias	+105°C environment while under bias for 1,000 hours. (ICE 68-2-2 Test Ba)
Low Temperature Bias	-40°C environment while under bias for 1,000 hours. (ICE 68-2-2 Test Aa)
Temperature / Humidity Bias	+85°C/85% R.H. environment while under bias for 1,000 hours. (JESD22-A101A-B)
Vibration	4 cycles lasting 12 minutes from 20 TO 2,000 Hz in X, Y and Z direction with peak acceleration of 20g. (MIL 883E, Method 2007.2, A)
Electrostatic Discharge	3 discharges at +/-8kV direct contact to lid when unit is grounded (IEC 61000-4-2) and 3 discharges at +/-2kV direct contact to I/O pins. (MIL 883E, Method 3015.7)
Reflow	5 reflow cycles with peak temperature of +260°C.
Mechanical Shock	3 pulses of 10,000g in the X, Y and Z direction. (IEC 68-2-27, Test Ea)

**14. SPECIFICATION REVISIONS**

Revision	Detailed Specification Changes	Date
D	Initial release. (DMS, C10109839)	7-20-2009
E	ROTATED LASER MARKING 90-DEGREES, CW TO MATCH PRODUCTION; ADDED DIMENSION FOR CORNER RADII OF CARRIER TAPE. (DMS, C10110197)	10-23-2009

The information contained in this literature is based on our experience to date and is believed to be reliable and it is subject to change without notice. It is intended as a guide for use by persons having technical skill at their own discretion and risk. We do not guarantee favorable results or assume any liability in connection with its use. Dimensions contained herein are for reference purposes only. For specific dimensional requirements consult factory. This publication is not to be taken as a license to operate under, or recommendation to infringe any existing patents. This supersedes and voids all previous literature.