

REVISIONS				
ZONE	REV	DESCRIPTION	DATE	APPROVED

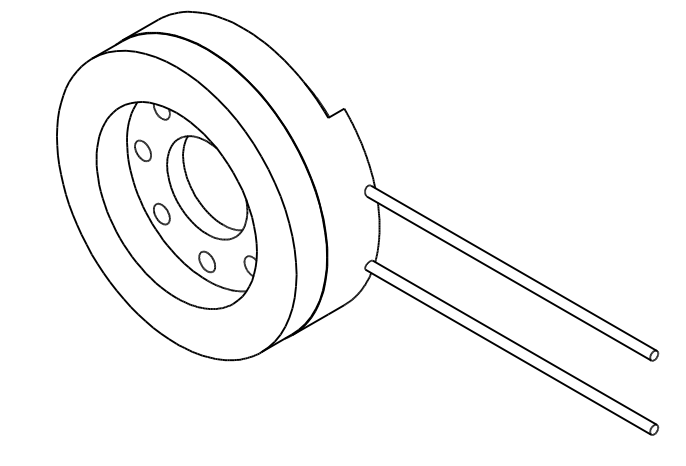

No.	Part Name	Material	Quantity
1	Wire (45mm)	UL1571 AWG32#	2
2	PCB	0.4 Tinplate	1
3	Frame	PBT	1
4	Magnet	NdFeB	1
5	Plate	SPCC	1
6	Voice Coil	Cu	1
7	Membrane	PEN	1
8	Cap	SUS201	1
9	Screen Gasket	PE + Double-sided adhesive +180Mesh	1
10	Gasket	PE+ Double-sided adhesive	1

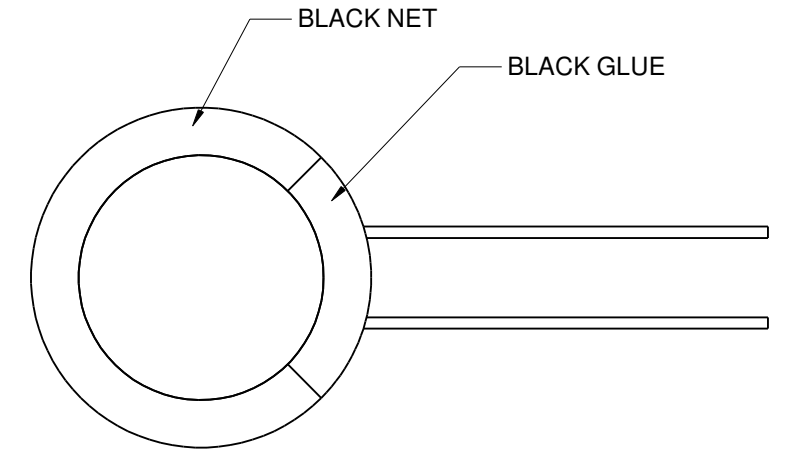
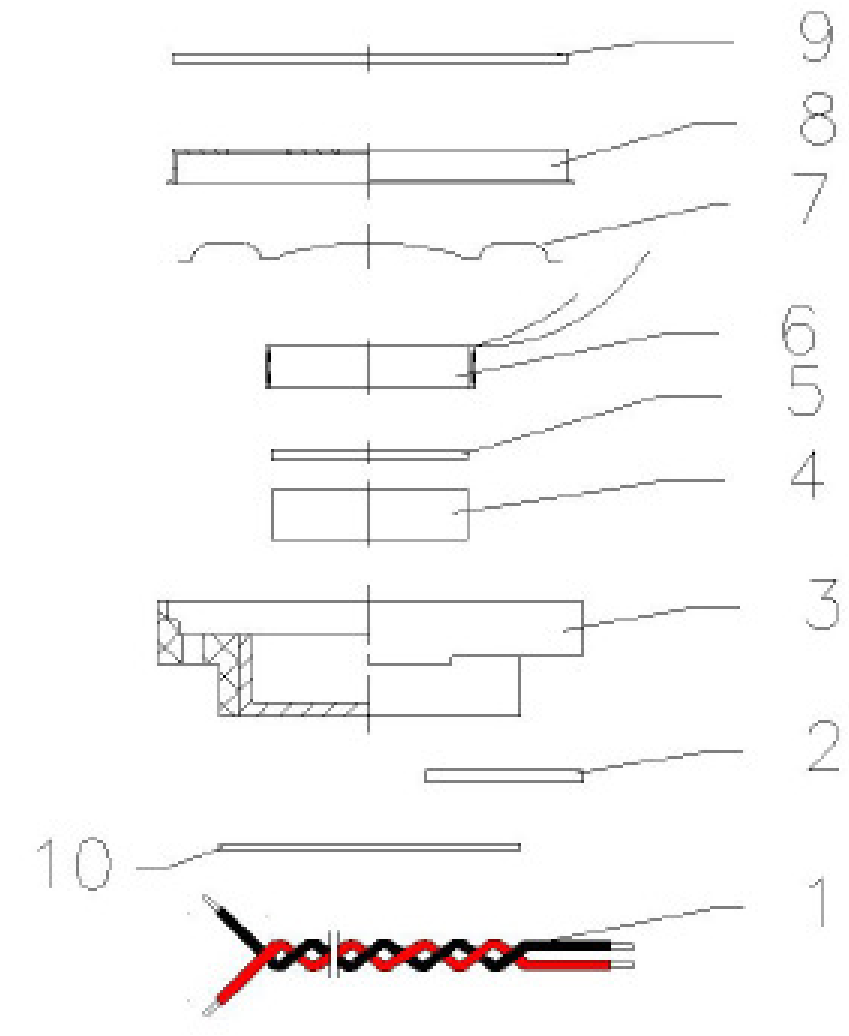