

TMC2209 SilentStepStick

Document Revision V1.20 • Hardware Revision V2.0 • 2020-Aug-12

Module Top View

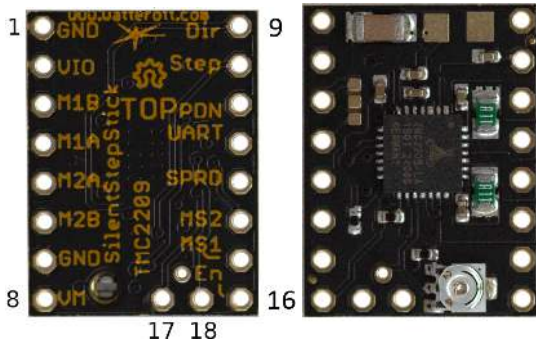

Features and additional Resources

- TMC2209-LA stepper motor controller & driver
- Supply voltage 4.75-28V
- Continuous $I_{phase} = 1.4A_{RMS}$
- I_{phase} up to $1.77A_{RMS} = 2.5A_{peak}$ for a short time
- Quiet operation with StealthChop™
- Sensorless homing with StallGuard4™
- Energy savings with CoolStep™
- Configuration and extended diagnostics via UART
- Control via Step&Dir interface
- Board width 0.6", board height 0.8"
- 2x8 pin 0.1" header rows for pins/connectors
- Link to [additional information and IC data sheet](#)

Pin List

Left	Signal	Right	Signal
1	GND	9	Dir
2	VIO	10	Step
3	M1B (Motor Phase B)	11	PDN
4	M1A (Motor Phase A)	12	UART
5	M2A (Motor Phase A)	13	SPRD
6	M2B (Motor Phase B)	14	MS2
7	GND	15	MS1
8	VM	16	EN
17	INDEX	18	DIAG

Bill of Materials

Pcs.	MPN	Value	Footprint	Description
1	100nF	100nF, 10V	0402	Capacitor
3	100nF	100nF, 50V	0402	Capacitor
2	10uF	10uF, 35V	1206	Capacitor
1	1uF	1uF, 50V	0805	Capacitor
1	POT-EVM3R	20k	POT_EVM3R	Potentiometer
3	RESISTOR-0402	20k	0402	Resistor
1	CAPACITOR-0402	22n/50V	0402	Capacitor
1	CAPACITOR-0402	4u7/6V3	0402	Capacitor
2	OR11	R0805/OR11	0805	Resistor
1	TMC2209-LA	TMC2209-LA	QFN28-PAD3.7	TRINAMIC TMC2209

Schematics

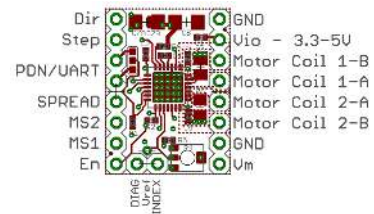
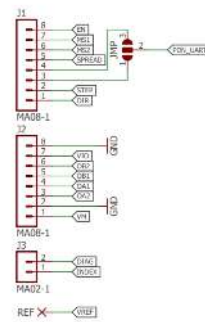
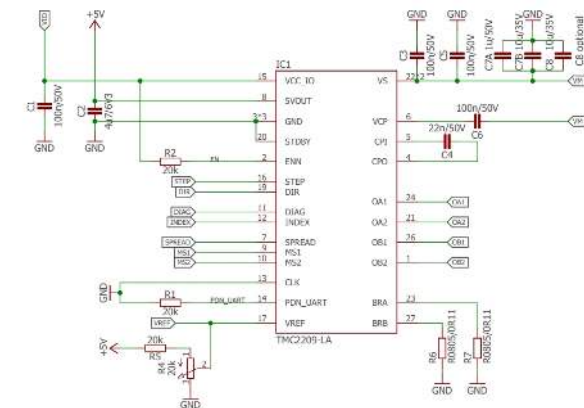

V_{Ref} 0...2.8V (0.11 Ohm sense resistor)
 >=2.55V 100% - 1.77A RMS
 1.25V 80% - 0.88A RMS
 0.55V 20% - 0.35A RMS

EN (with pull-up)
 GND driver enabled
 VCC driver disabled

PDN/UART (with pull-down)
 GND automatic standstill current reduction
 VCC automatic standstill power down disable
 optional UART interface

MS1	MS2	Steps	Interpolation
GND	GND	0	Yes to 256
UID	SND	32	Yes to 256
GND	UID	64	Yes to 256
UID	UID	16	Yes to 256

SPREAD (with pull-down)
 GND stealthChop
 UID spreadCycle

To access all other modes you have to use the UART interface.

©2020 TRINAMIC Motion Control GmbH & Co. KG, Hamburg, Germany
 Terms of delivery and rights to technical change reserved.
 Download newest version at www.trinamic.com

