



74ACTQ32

Quiet Series Quad 2-Input OR Gate

Features

- I_{CC} reduced by 50%
- Guaranteed simultaneous switching noise level and dynamic threshold performance
- Improved latch-up immunity
- Minimum 4kV ESD protection
- TTL-compatible inputs
- Outputs source/sink 24mA

General Description

The ACTQ320 contains four, 2-input OR gates and utilizes Fairchild Quiet Series technology to guarantee quiet output switching and improved dynamic threshold performance. FACT Quiet Series™ features GTO™ output control and undershoot corrector in addition to a split ground bus for superior ACMOS performance.

Ordering Information

| Order Number | Package Number | Package Description |
|--------------|----------------|--|
| 74ACTQ32SC | M14A | 14-Lead Small Outline Integrated Circuit (SOIC), JEDEC MS-012, 0.150" Narrow |
| 74ACTQ32SJ | M14D | 14-Lead Small Outline Package (SOP), EIAJ TYPE II, 5.3mm Wide |

Device also available in Tape and Reel. Specify by appending suffix letter "X" to the ordering number.

Connection Diagram

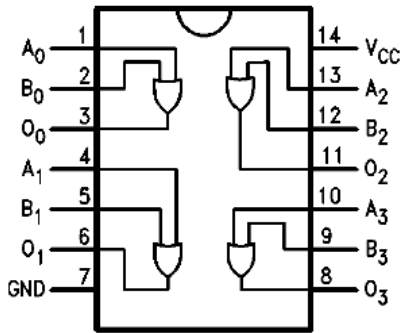

Logic Symbol

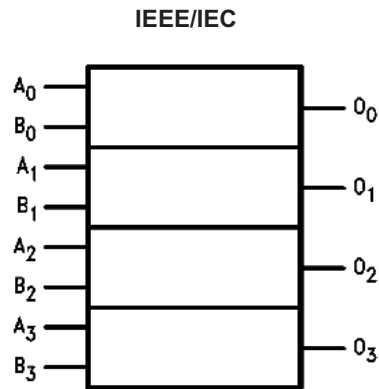

Pin Description

| Pin Names | Descriptions |
|-------------|--------------|
| A_n, B_n | Inputs |
| \bar{O}_n | Outputs |

FACT™, FACT Quiet Series™, and GTO™ are trademarks of Fairchild Semiconductor Corporation.

Absolute Maximum Ratings

Stresses exceeding the absolute maximum ratings may damage the device. The device may not function or be operable above the recommended operating conditions and stressing the parts to these levels is not recommended. In addition, extended exposure to stresses above the recommended operating conditions may affect device reliability. The absolute maximum ratings are stress ratings only.

| Symbol | Parameter | Rating |
|-----------------------|--|--------------------------|
| V_{CC} | Supply Voltage | -0.5V to +7.0V |
| I_{IK} | DC Input Diode Current | |
| | $V_I = -0.5V$ $V_I = V_{CC} + 0.5V$ | -20mA +20mA |
| V_I | DC Input Voltage | -0.5V to $V_{CC} + 0.5V$ |
| I_{OK} | DC Output Diode Current | |
| | $V_O = -0.5V$ $V_O = V_{CC} + 0.5V$ | -20mA +20mA |
| V_O | DC Output Voltage | -0.5V to $V_{CC} + 0.5V$ |
| I_O | DC Output Source or Sink Current | $\pm 50mA$ |
| I_{CC} or I_{GND} | DC V_{CC} or Ground Current per Output Pin | $\pm 50mA$ |
| T_{STG} | Storage Temperature | -65°C to +150°C |
| | DC Latch-Up Source or Sink Current | $\pm 300mA$ |
| T_J | Junction Temperature | 140°C |

Recommended Operating Conditions

The Recommended Operating Conditions table defines the conditions for actual device operation. Recommended operating conditions are specified to ensure optimal performance to the datasheet specifications. Fairchild does not recommend exceeding them or designing to absolute maximum ratings.

| Symbol | Parameter | Rating |
|-----------------------|---|----------------|
| V_{CC} | Supply Voltage | 4.5V to 5.5V |
| V_I | Input Voltage | 0V to V_{CC} |
| V_O | Output Voltage | 0V to V_{CC} |
| T_A | Operating Temperature | -40°C to +85°C |
| $\Delta V / \Delta t$ | Minimum Input Edge Rate: V_{IN} from 0.8V to 2.0V, V_{CC} @ 4.5V, 5.5V | 125mV/ns |

DC Electrical Characteristics

| Symbol | Parameter | V _{CC} (V) | Conditions | T _A = +25°C | | T _A = -55°C to +125°C | T _A = -40°C to +85°C | Units |
|------------------|---|------------------------|---|------------------------|-------------------|-------------------------------------|------------------------------------|-------|
| | | | | Typ. | Guaranteed Limits | | | |
| V _{IH} | Minimum HIGH Level Input Voltage | 4.5 | V _{OUT} = 0.1V or V _{CC} - 0.1V | 1.5 | 2.0 | 2.0 | 2.0 | V |
| | | 5.5 | | 1.5 | 2.0 | 2.0 | 2.0 | |
| V _{IL} | Maximum LOW Level Input Voltage | 4.5 | V _{OUT} = 0.1V or V _{CC} - 0.1V | 1.5 | 0.8 | 0.8 | 0.8 | V |
| | | 5.5 | | 1.5 | 0.8 | 0.8 | 0.8 | |
| V _{OH} | Minimum HIGH Level Output Voltage | 4.5 | I _{OUT} = -50μA | 4.49 | 4.4 | 4.4 | 4.4 | V |
| | | 5.5 | | 5.49 | 5.4 | 5.4 | 5.4 | |
| | | 4.5 | V _{IN} = V _{IL} or V _{IH} : I _{OH} = -24mA | | 3.86 | 3.70 | 3.76 | |
| | | 5.5 | I _{OH} = -24mA ⁽¹⁾ | | 4.86 | 4.70 | 4.76 | |
| V _{OL} | Maximum LOW Level Output Voltage | 4.5 | I _{OUT} = 50μA | 0.001 | 0.1 | 0.1 | 0.1 | V |
| | | 5.5 | | 0.001 | 0.1 | 0.1 | 0.1 | |
| | | 4.5 | V _{IN} = V _{IL} or V _{IH} : I _{OL} = 24mA | | 0.36 | 0.50 | 0.44 | |
| | | 5.5 | I _{OL} = 24mA ⁽¹⁾ | | 0.36 | 0.50 | 0.44 | |
| I _{IN} | Maximum Input Leakage Current | 5.5 | V _I = V _{CC} , GND | | ±0.1 | ±1.0 | ±1.0 | μA |
| I _{CCT} | Maximum I _{CC} /Input | 5.5 | V _I = V _{CC} - 2.1V | 0.6 | | 1.6 | 1.5 | mA |
| I _{OLD} | Minimum Dynamic Output Current ⁽²⁾ | 5.5 | V _{OLD} = 1.65V Max. | | | 50 | 75 | mA |
| I _{OHD} | | 5.5 | V _{OHD} = 3.85V Min. | | | -50 | -75 | mA |
| I _{CC} | Maximum Quiescent Supply Current | 5.5 | V _{IN} = V _{CC} or GND | | 2.0 | 40.0 | 20.0 | μA |
| V _{OLP} | Quiet Output Maximum Dynamic V _{OL} | 5.0 | Figures 1 & 2 ⁽³⁾ | 1.1 | 1.5 | | | V |
| V _{OLV} | Quiet Output Minimum Dynamic V _{OL} | 5.0 | Figures 1 & 2 ⁽³⁾ | -0.6 | -1.2 | | | V |
| V _{IHD} | Minimum HIGH Level Dynamic Input Voltage | 5.0 | ⁽⁴⁾ | 1.9 | 2.2 | | | V |
| V _{ILD} | Maximum LOW Level Dynamic Input Voltage | 5.0 | ⁽⁴⁾ | 1.2 | 0.8 | | | V |

Notes:

- All outputs loaded; thresholds on input associated with output under test.
- Maximum test duration 2.0ms, one output loaded at a time.
- Max number of outputs defined as (n). Data inputs are 0V to 3V. One output @ GND.
- Max number of data inputs (n) switching. (n-1) inputs switching 0V to 3V (ACTQ). Input-under-test switching: 3V to threshold (V_{ILD}), 0V to threshold (V_{IHD}), f = 1MHz.

AC Electrical Characteristics

| Symbol | Parameter | V _{CC} (V) ⁽⁵⁾ | T _A = +25°C, C _L = 50 pF | | | T _A = -40°C to +85°C, C _L = 50 pF | | Units |
|---------------------------------------|--------------------------------------|------------------------------------|---|------|------|--|-----|-------|
| | | | Min. | Typ. | Max. | Min | Max | |
| t _{PLH} | Propagation Delay, Data to Output | 5.0 | 2.5 | 6.0 | 6.5 | 2.5 | 7.0 | ns |
| t _{PHL} | Propagation Delay, Data to Output | 5.0 | 2.0 | 6.0 | 6.5 | 2.5 | 7.0 | ns |
| t _{OSSL} , t _{OSLH} | Output to Output Skew ⁽⁶⁾ | 5.0 | | 0.5 | 1.0 | | 1.0 | ns |

Notes:

- Voltage range 5.0 is 5.0V ± 0.5V.
- Skew is defined as the absolute value of the difference between the actual propagation delay for any two separate outputs of the same device. The specification applies to any outputs switching in the same direction, either HIGH-to-LOW (t_{OSSL}) or LOW-to-HIGH (t_{OSLH}). Parameter guaranteed by design.

Capacitance

| Symbol | Parameter | Conditions | Typ. | Units |
|-----------------|-------------------------------|------------------------|------|-------|
| C _{IN} | Input Capacitance | V _{CC} = OPEN | 4.5 | pF |
| C _{PD} | Power Dissipation Capacitance | V _{CC} = 5.0V | 68 | pF |

FACT Noise Characteristics

The setup of a noise characteristics measurement is critical to the accuracy and repeatability of the tests. The following is a brief description of the setup used to measure the noise characteristics of FACT.

Equipment

Hewlett Packard Model 8180A Word Generator

PC-163A Test Fixture

Tektronics Model 7854 Oscilloscope

Procedure:

1. Verify Test Fixture Loading: Standard Load 50pF, 500Ω.
2. Deskew the HFS generator so that no two channels have greater than 150ps skew between them. This requires that the oscilloscope be deskewed first. It is important to deskew the HFS generator channels before testing. This will ensure that the outputs switch simultaneously.
3. Terminate all inputs and outputs to ensure proper loading of the outputs and that the input levels are at the correct voltage.
4. Set the HFS generator to toggle all but one output at a frequency of 1MHz. Greater frequencies will increase DUT heating and effect the results of the measurement.

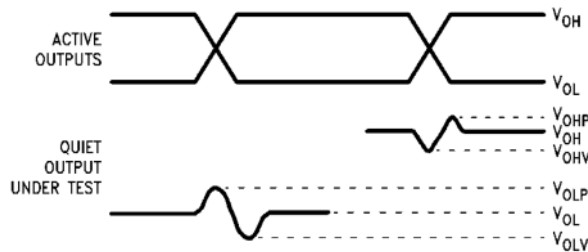

Notes:

7. V_{OHV} and V_{OLP} are measured with respect to ground reference.
8. Input pulses have the following characteristics:
 $f = 1\text{MHz}$, $t_r = 3\text{ns}$, $t_f = 3\text{ns}$, skew < 150ps.

Figure 1. Quiet Output Noise Voltage Waveforms

5. Set the HFS generator input levels at 0V LOW and 3V HIGH for ACTQ devices and 0V LOW and 5V HIGH for AC devices. Verify levels with an oscilloscope.

V_{OLP}/V_{OLV} and V_{OHP}/V_{OHV} :

- Determine the quiet output pin that demonstrates the greatest noise levels. The worst case pin will usually be the furthest from the ground pin. Monitor the output voltages using a 50Ω coaxial cable plugged into a standard SMB type connector on the test fixture. Do not use an active FET probe.
- Measure V_{OLP} and V_{OLV} on the quiet output during the worst case transition for active and enable. Measure V_{OHP} and V_{OHV} on the quiet output during the worst case transition.
- Verify that the GND reference recorded on the oscilloscope has not drifted to ensure the accuracy and repeatability of the measurements.

V_{ILD} and V_{IHD} :

- Monitor one of the switching outputs using a 50Ω coaxial cable plugged into a standard SMB type connector on the test fixture. Do not use an active FET probe.
- First increase the input LOW voltage level, V_{IL} , until the output begins to oscillate or steps out a min of 2ns. Oscillation is defined as noise on the output LOW level that exceeds V_{IL} limits, or on output HIGH levels that exceed V_{IH} limits. The input LOW voltage level at which oscillation occurs is defined as V_{ILD} .
- Next decrease the input HIGH voltage level, V_{IH} , until the output begins to oscillate or steps out a min of 2ns. Oscillation is defined as noise on the output LOW level that exceeds V_{IL} limits, or on output HIGH levels that exceed V_{IH} limits. The input HIGH voltage level at which oscillation occurs is defined as V_{IHD} .
- Verify that the GND reference recorded on the oscilloscope has not drifted to ensure the accuracy and repeatability of the measurements.

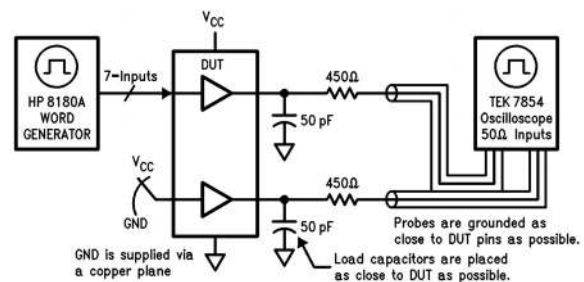
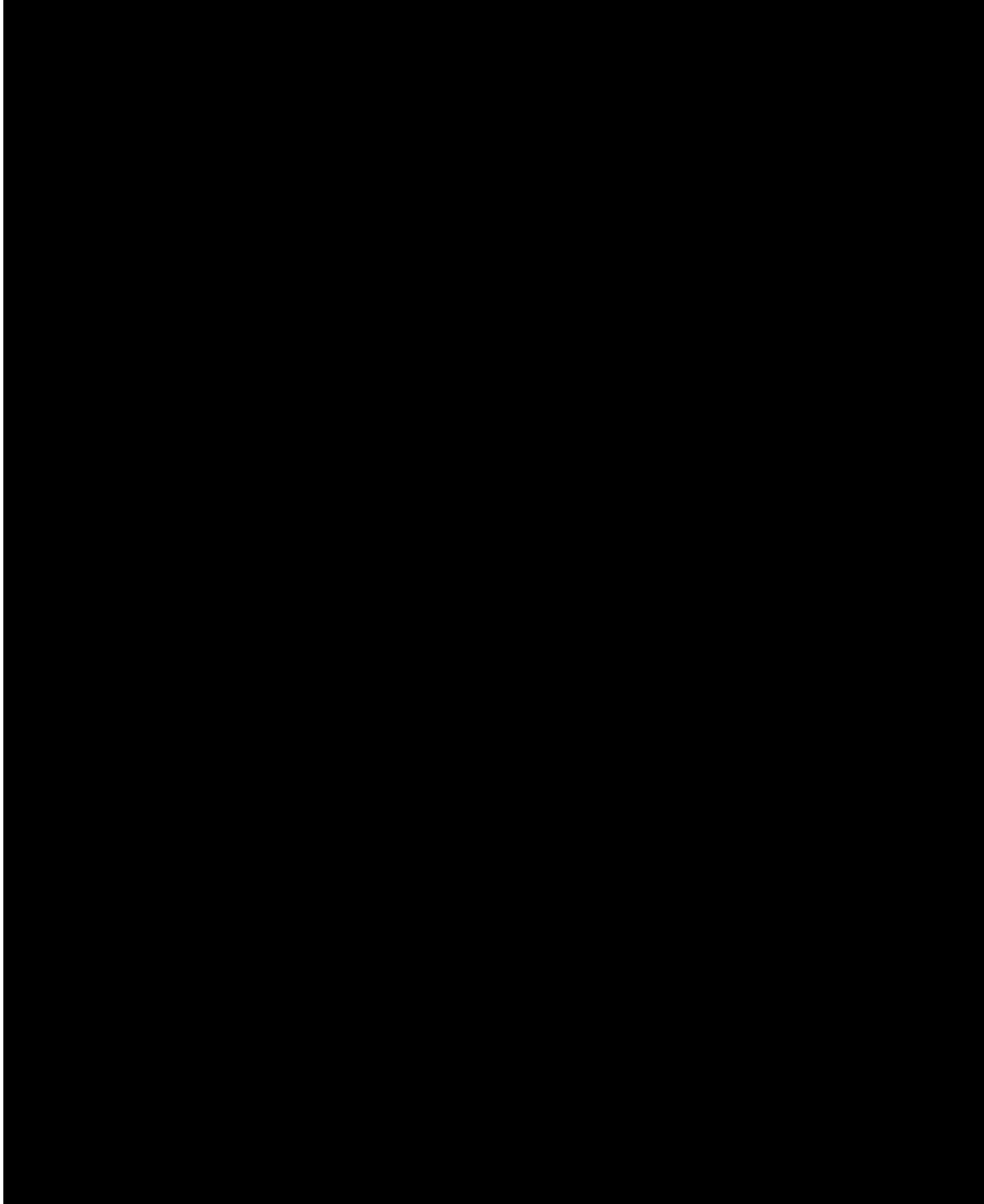

Figure 2. Simultaneous Switching Test Circuit

Physical Dimensions

Dimensions are in inches (millimeters) unless otherwise noted.



**Figure 3. 14-Lead Small Outline Integrated Circuit (SOIC), JEDEC MS-012, 0.150" Narrow
Package Number M14A**

Physical Dimensions (Continued)

Dimensions are in millimeters unless otherwise noted.

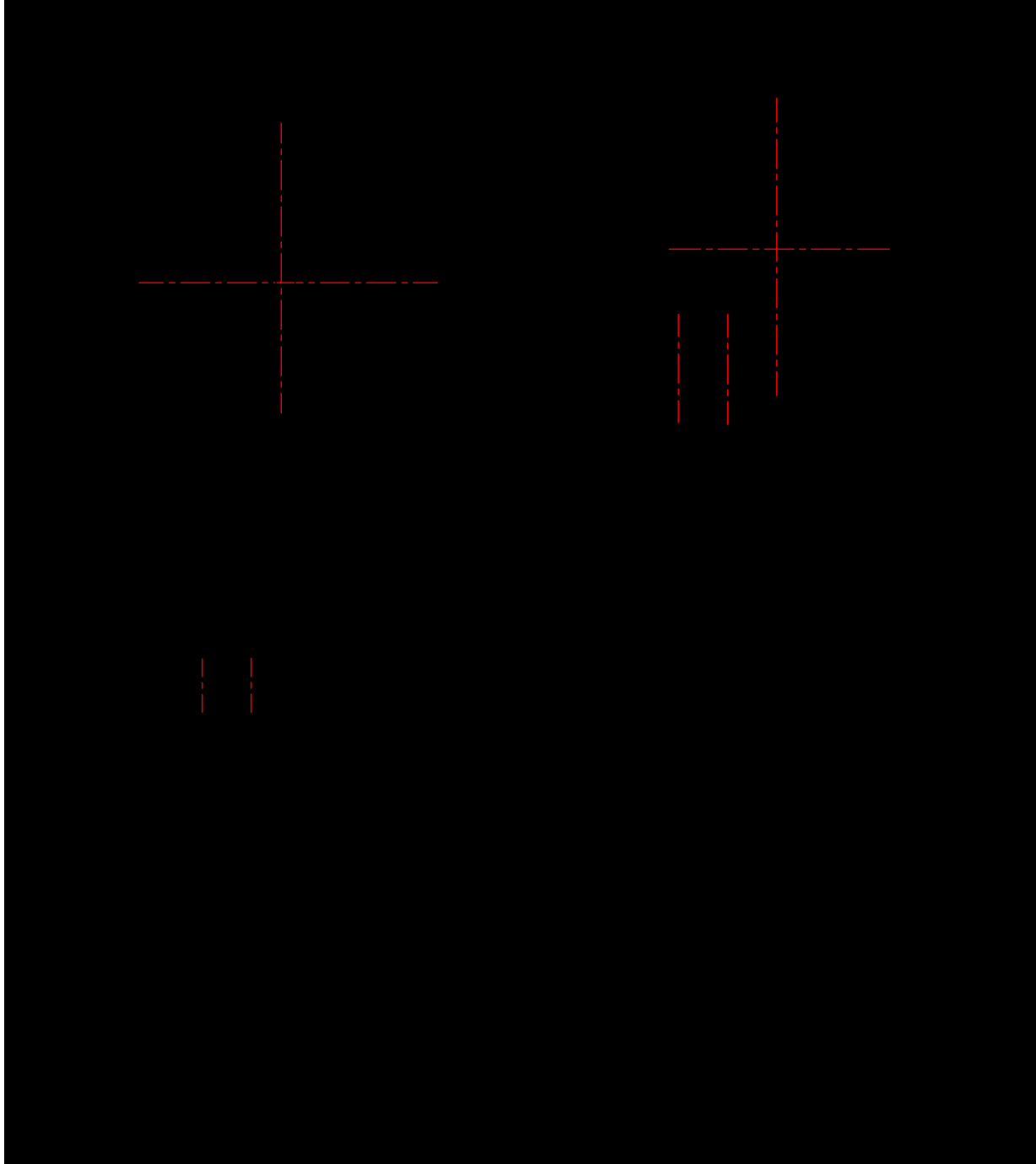

**Figure 4. 14-Lead Small Outline Package (SOP), EIAJ TYPE II, 5.3mm Wide
Package Number M14D**

