

Description

The AP2129 is a 300mA, positive Voltage regulator ICs fabricated by CMOS process. The AP2129 provides two kinds of output voltage operation modes for setting the output voltage. Fixed output voltage mode senses the output voltage on V_{OUT} , adjustable output voltage mode needs two resistors as a voltage divider.

The AP2129 series have features of low dropout voltage, low noise, high output voltage accuracy, and low current consumption which make them ideal for use in various battery-powered devices.

The AP2129 has 1.0V, 1.2V, 1.8V, 2.6V, 2.8V, 3.0V and 3.3V fixed voltage version and 0.8V to 4.5V adjustable voltage version.

The AP2129 series are available in DFN-1.5x2-6 (1.0V, 1.2V, 1.8V, 2.6V, 2.8V, 3.0V, 3.3V) and SOT-23-5 (1.0V, 1.2V, 3.3V, ADJ) packages.

Features

- Wide Operating Voltage: 1.8V to 6V
- High Output Voltage Accuracy: $\pm 2\%$
- High Ripple Rejection: 65dB@ $f = 1\text{kHz}$, 45dB@ $f = 10\text{kHz}$
- Low Standby Current: 0.1 μA
- Low Quiescent Current: 60 μA Typical
- Low Output Noise: 60 μVrms
- Short Current Limit: 50mA
- Over Temperature Protection
- Compatible with Low ESR Ceramic Capacitor: 1 μF for C_{IN} and C_{OUT}
- Excellent Line/Load Regulation
- Soft Start Time: 50 μs
- Auto Discharge Resistance: $R_{DS(ON)} = 60\Omega$

Pin Assignments

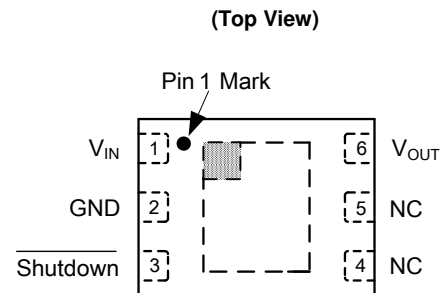

DFN-1.5x2-6

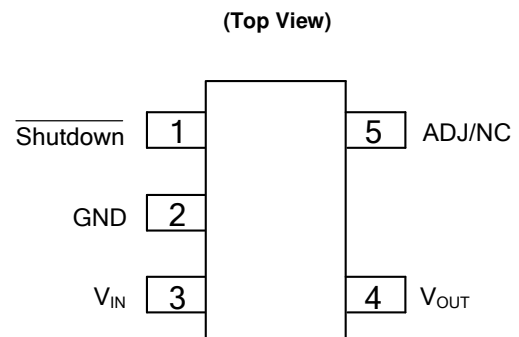

SOT-23-5

Applications

- Datacom
- Notebook Computers
- Mother Board

Typical Applications Circuit

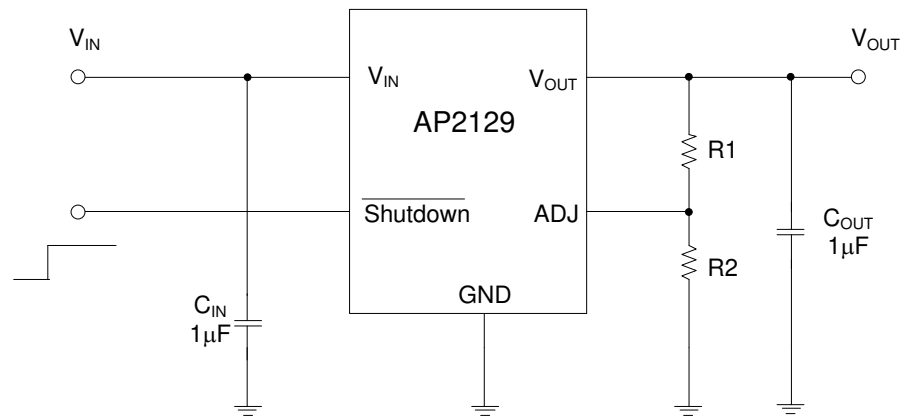

$$V_{OUT} = 0.8 \cdot (1 + R1/R2) V$$

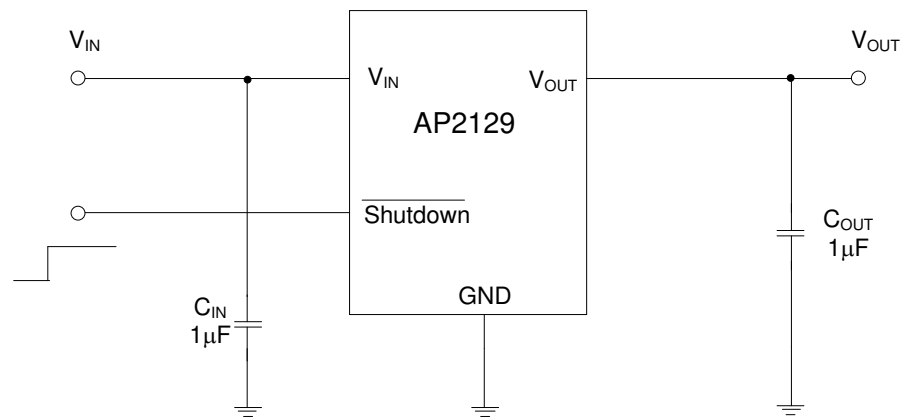

$$V_{OUT} = 1.0V, 1.2V, 1.8V, 2.6V, 2.8V, 3.0V, 3.3V$$

Pin Descriptions

Pin Number		Pin Name	Function
DFN-1.5x2-6	SOT-23-5		
1	3	V _{IN}	Input Voltage
2	2	GND	Ground
3	1	Shutdown	Active High Enable Input Pin. Logic high=enable, logic low=shutdown
4, 5	—	NC	No Connection
—	5	ADJ/NC	Adjust Output for ADJ version/No Connection for Fixed Version
6	4	V _{OUT}	Regulated Output Voltage

Functional Block Diagram

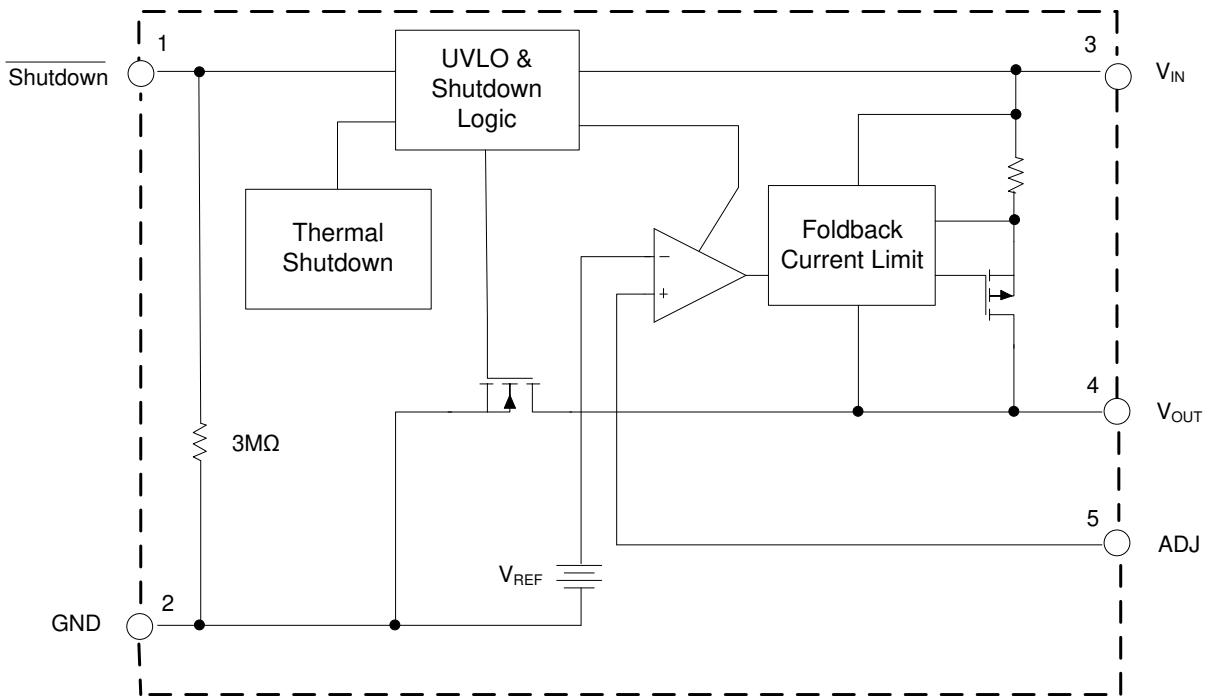
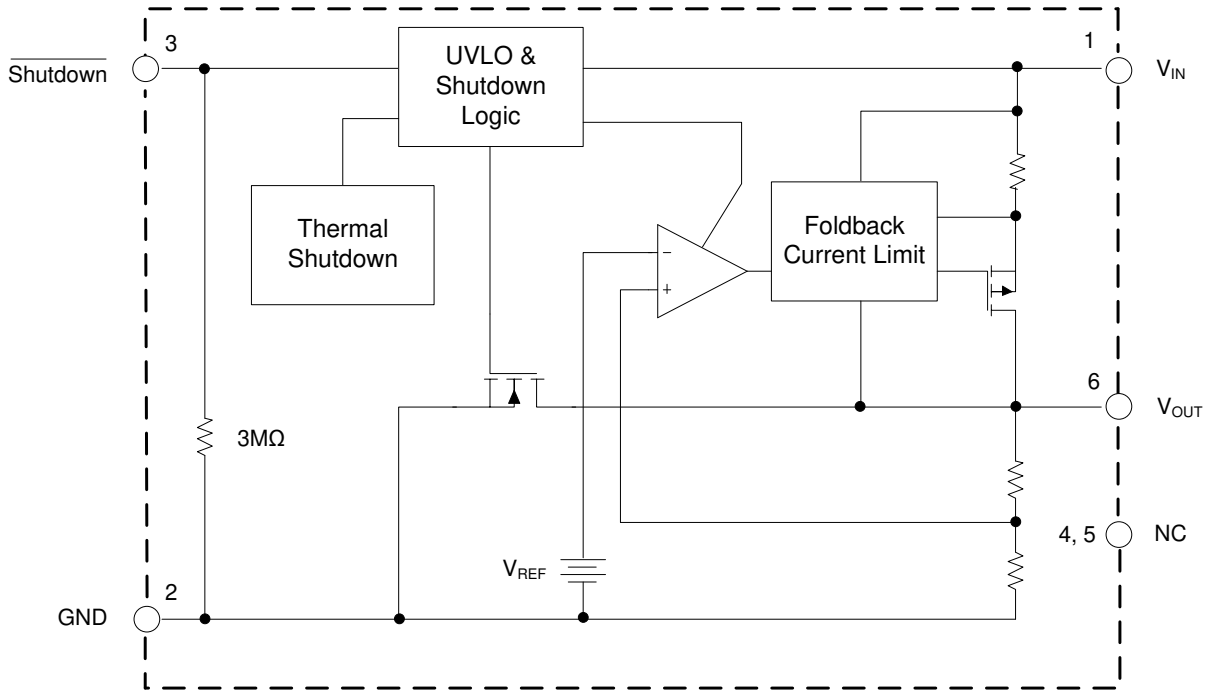

Absolute Maximum Ratings (Note 1)

Symbol	Parameter	Rating		Unit
V_{IN}	Input Voltage	6.5		V
V_{CE}	Shutdown Input Voltage	-0.3 to $V_{IN} + 0.3$		V
I_{OUT}	Output Current	450		mA
T_J	Junction Temperature	+150		°C
T_{STG}	Storage Temperature Range	-65 to +150		°C
T_{LEAD}	Lead Temperature (Soldering, 10sec)	+260		°C
θ_{JA}	Thermal Resistance (Junction to Ambient)	DFN-1.5x2-6	100	°C/W
		SOT-23-5	250	
ESD	ESD (Human Body Model)	6000		V
ESD	ESD (Machine Model)	200		V

Note 1: Stresses greater than those listed under “Absolute Maximum Ratings” may cause permanent damage to the device. These are stress ratings only, and functional operation of the device at these or any other conditions beyond those indicated under “Recommended Operating Conditions” is not implied. Exposure to “Absolute Maximum Ratings” for extended periods may affect device reliability.

Recommended Operating Conditions

Symbol	Parameter	Min	Max	Unit
V_{IN}	Input Voltage	1.8	6	V
T_A	Operating Ambient Temperature Range	-40	+85	°C

Electrical Characteristics
AP2129-1.0/1.2/1.8/2.6/2.8/3.0/3.3 Electrical Characteristics (@C_{IN} = 1μF, C_{OUT} = 1μF, **Bold** type applies over -40°C ≤ T_J ≤ +85°C, unless otherwise specified.)

Symbol	Parameter	Conditions	Min	Typ	Max	Unit	
V _{OUT}	Output Voltage	V _{IN} = V _{OUT} + 1V, (Note 2) 1mA ≤ I _{OUT} ≤ 300mA	98%* V _{OUT}	—	102%* V _{OUT}	V	
V _{IN}	Input Voltage	—	1.8	—	6	V	
I _{OUT(MAX)}	Maximum Output Current	—	—	450	—	mA	
ΔV _{OUT} /(ΔI _{OUT} *V _{OUT})	Load Regulation	V _{IN} -V _{OUT} = 1V, (Note 2), 1mA ≤ I _{OUT} ≤ 300mA	—	—	1.5	%/A	
ΔV _{OUT} /(ΔV _{IN} *V _{OUT})	Line Regulation	V _{OUT} + 0.5V ≤ V _{IN} ≤ 6V, (Note 2), I _{OUT} = 30mA	—	—	0.06	%/V	
V _{DROP}	Dropout Voltage	V _{OUT} = 1.0V, I _{OUT} = 300mA	—	800	—	mV	
		V _{OUT} = 1.2V, I _{OUT} = 300mA	—	600	—		
		V _{OUT} = 1.8V, I _{OUT} = 300mA	—	600	700		
		V _{OUT} = 2.6V/2.8V/3.0V/3.3V, I _{OUT} = 300mA	—	170	300		
I _Q	Quiescent Current	V _{IN} = V _{OUT} + 1V, I _{OUT} = 0mA	—	60	90	μA	
I _{STD}	Standby Current	V _{IN} = V _{OUT} + 1V, V _{Shutdown} in off mode	—	0.1	1.0	μA	
PSRR	Power Supply Rejection Ratio	Ripple 1Vp-p, V _{IN} = V _{OUT} + 1V	f = 100Hz	—	65	—	dB
			f = 1kHz	—	65	—	dB
			f = 10kHz	—	45	—	dB
(ΔV _{OUT} /V _{OUT})/ΔT	Output Voltage Temperature Coefficient	I _{OUT} = 30mA, -40°C ≤ T _J ≤ +85°C	—	±100	—	ppm/°C	
I _{LIMIT}	Output Current Limit	V _{IN} -V _{OUT} = 1V, V _{OUT} = 0.98*V _{OUT}	—	400	—	mA	
I _{SHORT}	Short Current Limit	V _{OUT} = 0V	—	50	—	mA	
t _{UP}	Soft Start Time	—	—	50	—	μs	
V _{NOISE}	RMS Output Noise	T _A = +25°C, 10Hz ≤ f ≤ 100kHz	—	60	—	μVrms	
—	Shutdown "High" Voltage	Shutdown Input Voltage "High"	1.5	—	6	V	
—	Shutdown "Low" Voltage	Shutdown Input Voltage "Low"	0	—	0.4	V	
—	V _{OUT} Discharge MOSFET R _{DS(ON)}	Shutdown Input Voltage "Low"	—	60	—	Ω	
—	Shutdown Pull Down Resistance	—	—	3	—	MΩ	
—	Thermal Shutdown	—	—	+165	—	°C	
—	Thermal Shutdown Hysteresis	—	—	+30	—	°C	
θ _{JC}	Thermal Resistance	DFN-1.5x2-6	—	20	—	°C/W	
		SOT-23-5	—	150	—		

 Note 2: V_{IN} = 2.8V for 1.0 and 1.2 version.

Electrical Characteristics (Cont.)

AP2129-ADJ Electrical Characteristics (@C_{IN} = 1μF, C_{OUT} = 1μF, **Bold** type applies over -40°C ≤ T_J ≤ +85°C, unless otherwise specified.)

Symbol	Parameter	Conditions	Min	Typ	Max	Unit	
V _{REF}	Reference Voltage	V _{IN} = 1.8V 1mA ≤ I _{OUT} ≤ 300mA	0.748	0.8	0.816	V	
V _{IN}	Input Voltage	—	1.8	—	6	V	
I _{OUT(MAX)}	Maximum Output Current	—	—	450	—	mA	
ΔV _{OUT} /(ΔI _{OUT} *V _{OUT})	Load Regulation	V _{IN} -V _{OUT} = 1V, 1mA ≤ I _{OUT} ≤ 300mA	—	—	1.5	%/A	
ΔV _{OUT} /(ΔV _{IN} *V _{OUT})	Line Regulation	V _{OUT} +0.5V ≤ V _{IN} ≤ 6V, I _{OUT} = 30mA	—	—	0.06	%/V	
I _Q	Quiescent Current	V _{IN} = V _{OUT} +1V, I _{OUT} = 0mA	—	60	90	μA	
I _{STD}	Standby Current	V _{IN} = V _{OUT} +1V, V _{Shutdown} in off mode	—	0.1	1.0	μA	
PSRR	Power Supply Rejection Ratio	Ripple 1Vp-p, V _{IN} = V _{OUT} +1V	f = 100Hz	—	65	—	dB
			f = 1kHz	—	65	—	dB
			f = 10kHz	—	45	—	dB
(ΔV _{OUT} /V _{OUT})/ΔT	Output Voltage Temperature Coefficient	I _{OUT} = 30mA, -40°C ≤ T _J ≤ +85°C	—	±100	—	ppm/°C	
I _{LIMIT}	Output Current Limit	—	—	400	—	mA	
I _{SHORT}	Short Current Limit	V _{OUT} = 0V	—	50	—	mA	
t _{UP}	Soft Start Time	—	—	50	—	μs	
V _{NOISE}	RMS Output Noise	T _A = +25°C, 10Hz ≤ f ≤ 100kHz	—	60	—	μVrms	
—	Shutdown "High" Voltage	Shutdown Input Voltage "High"	1.5	—	6	V	
—	Shutdown "Low" Voltage	Shutdown Input Voltage "Low"	0	—	0.4	V	
—	V _{OUT} Discharge MOSFET R _{DS(ON)}	Shutdown Input Voltage "Low"	—	60	—	Ω	
—	Shutdown Pull Down Resistance	—	—	3	—	MΩ	
—	Thermal Shutdown	—	—	+165	—	°C	
—	Thermal Shutdown Hysteresis	—	—	+30	—	°C	
θ _{JC}	Thermal Resistance	DFN-1.5x2-6	—	20	—	°C/W	
		SOT-23-5	—	150	—		

Performance Characteristics

Output Voltage vs. Output Current

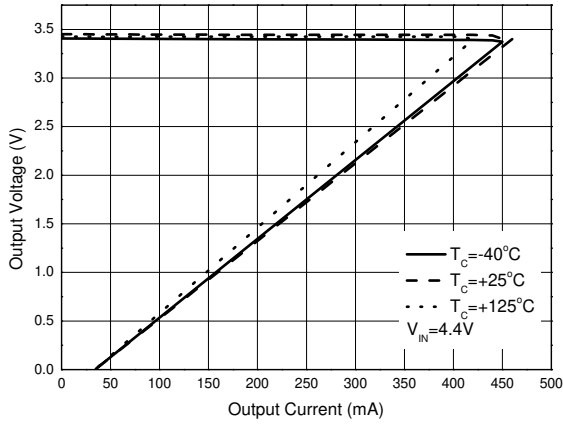

Supply Current vs. Input Voltage

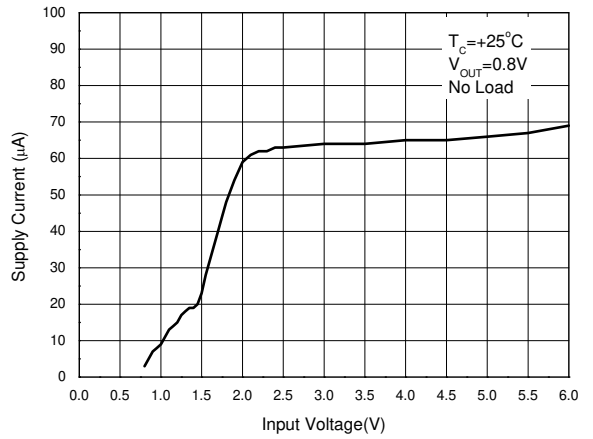

Supply Current vs. Output Current

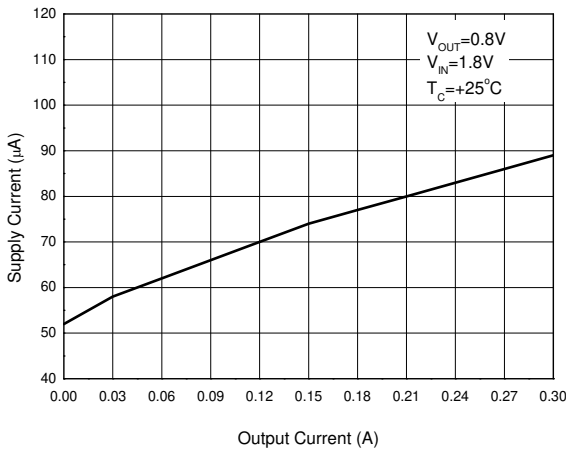

Supply Current vs. Case Temperature

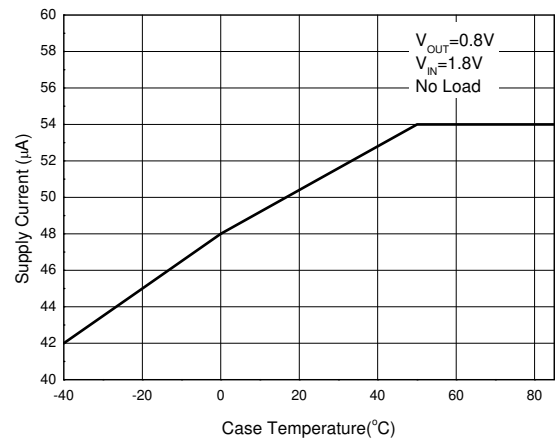

Short Current vs. Case Temperature

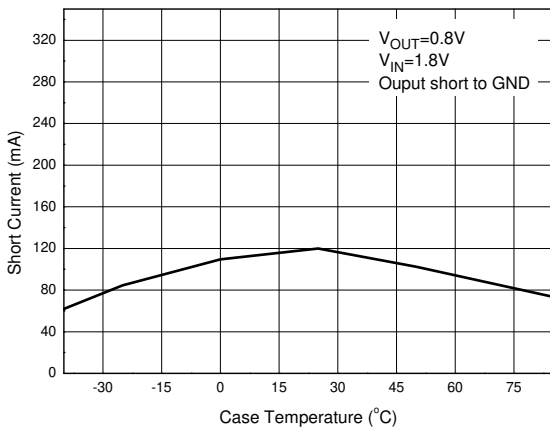

Output Voltage vs. Case Temperature

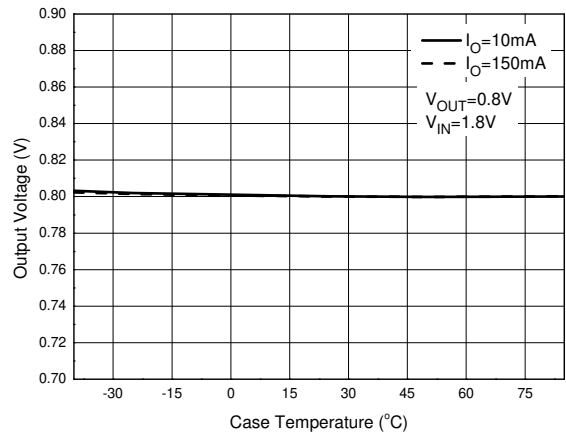

Performance Characteristics (Cont.)

Output Voltage vs. Output Current

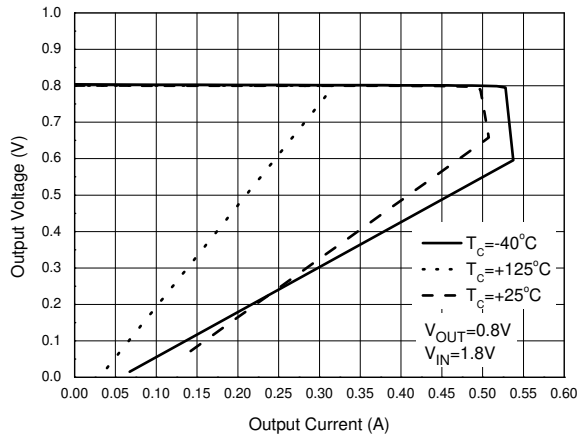

Output Voltage vs. Input Voltage

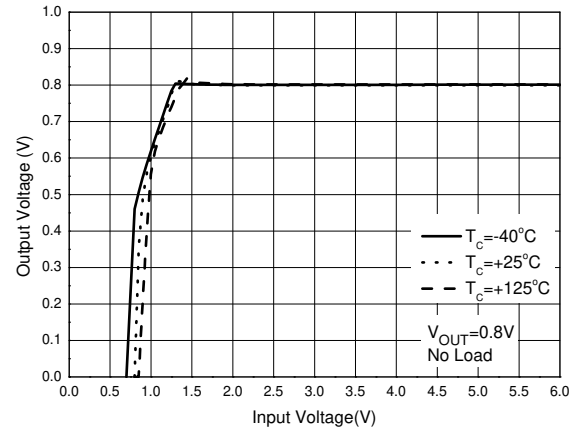

Output Voltage vs. Input Voltage (I_{OUT}=300mA)

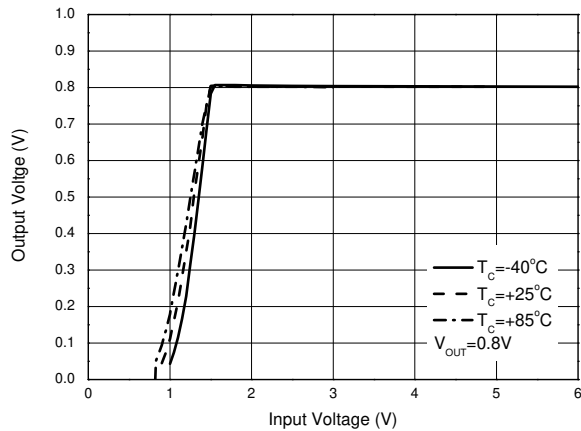

Load Transient
(Conditions: C_{IN}=C_{OUT}=1μF, V_{IN}=2.5V, V_{OUT}=0.8V)

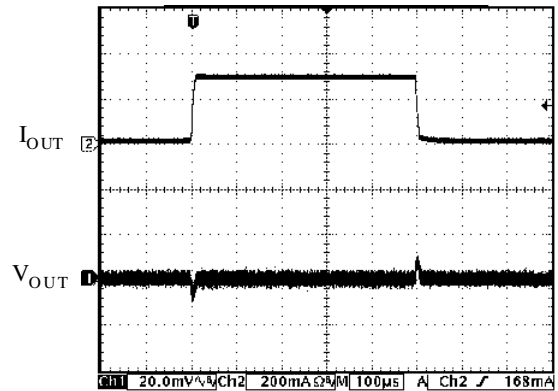

Load Transient
(Conditions: C_{IN}=C_{OUT}=1μF, V_{IN}=4.4V, V_{OUT}=3.3V)

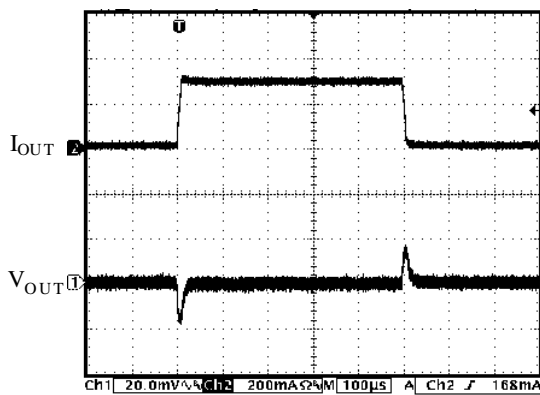

Line Transient
(Conditions: I_{OUT}=30mA, C_{IN}=C_{OUT}=1μF, V_{IN}=2.5 to 3.5V, V_{OUT}=0.8V)

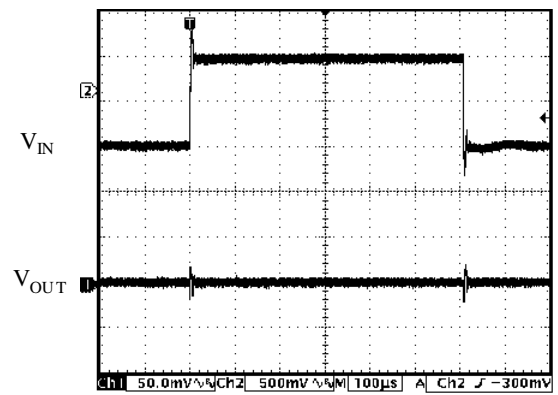

Performance Characteristics (Cont.)

Line Transient
(Conditions: $I_{OUT}=30mA$, $C_{IN}=C_{OUT}=1\mu F$,
 $V_{IN}=4$ to $5V$, $V_{OUT}=3.3V$)

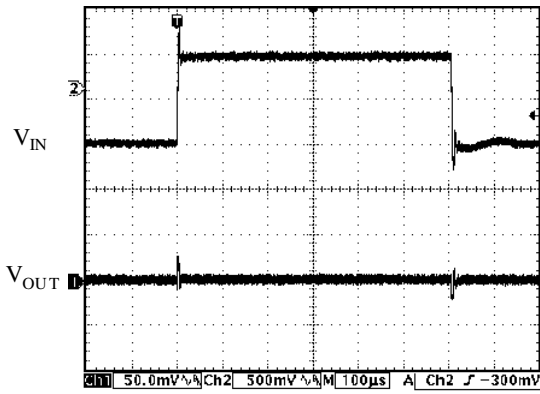

Soft Start Time
(Conditions: $I_{OUT}=0mA$, $C_{IN}=C_{OUT}=1\mu F$,
 $V_{Shutdown}=0$ to $2V$, $V_{OUT}=3.3V$)

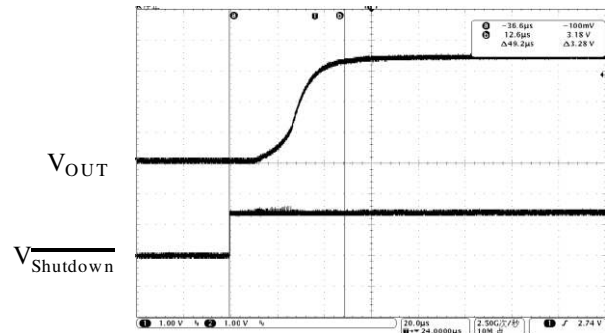

Soft Start Time
(Conditions: $I_{OUT}=0mA$, $C_{IN}=C_{OUT}=1\mu F$,
 $V_{Shutdown}=0$ to $2V$, $V_{OUT}=0.8V$)

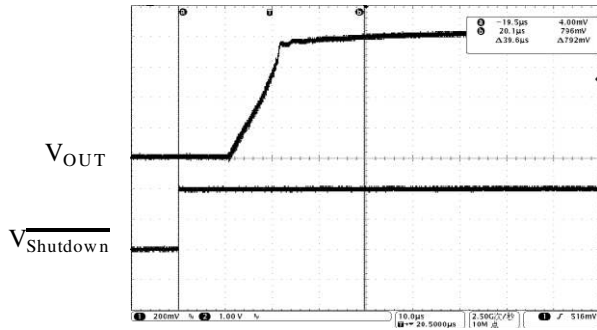

PSRR vs. Frequency

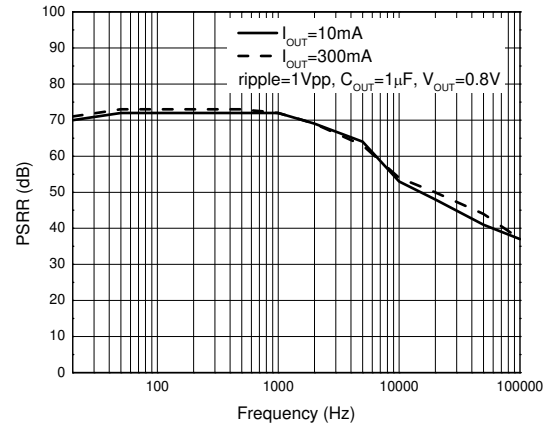

PSRR vs. Frequency

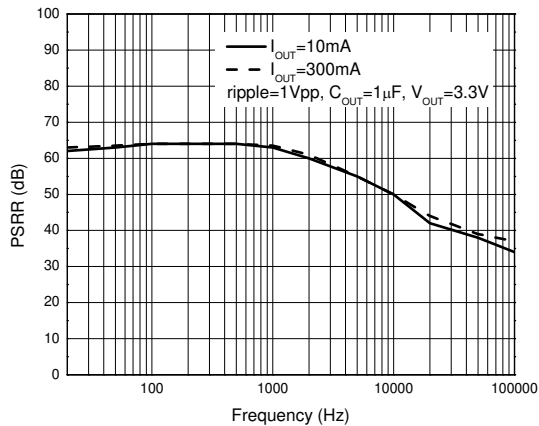

Power Dissipation vs. Case Temperature

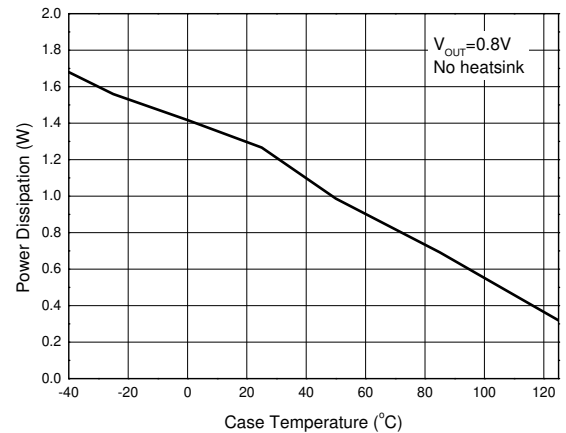

Ordering Information

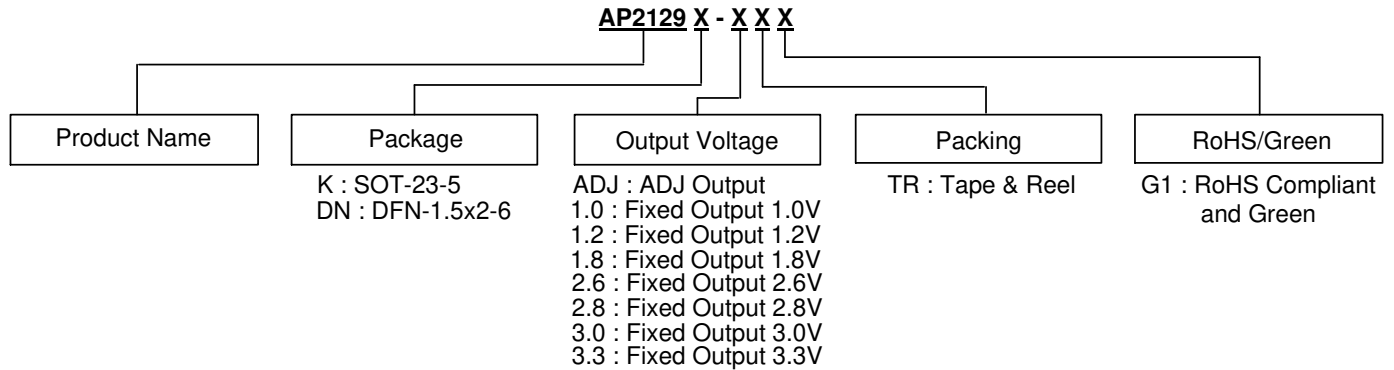

Package	Temperature Range	Part Number	Marking ID	Packing
SOT-23-5	-40 to +85°C	AP2129K- ADJTRG1	GEJ	Tape & Reel
		AP2129K-1.0TRG1	GEK	Tape & Reel
		AP2129K-1.2TRG1	GEL	Tape & Reel
		AP2129K-3.3TRG1	GEM	Tape & Reel
DFN-1.5x2-6	-40 to +85°C	AP2129DN-1.0TRG1	LA	Tape & Reel
		AP2129DN-1.2TRG1	MA	Tape & Reel
		AP2129DN-1.8TRG1	LB	Tape & Reel
		AP2129DN-2.6TRG1	MB	Tape & Reel
		AP2129DN-2.8TRG1	LC	Tape & Reel
		AP2129DN-3.0TRG1	MC	Tape & Reel
		AP2129DN-3.3TRG1	LD	Tape & Reel

Package Outline Dimensions (All dimensions in mm(inch).)

(1) Package Type: DFN-1.5x2-6

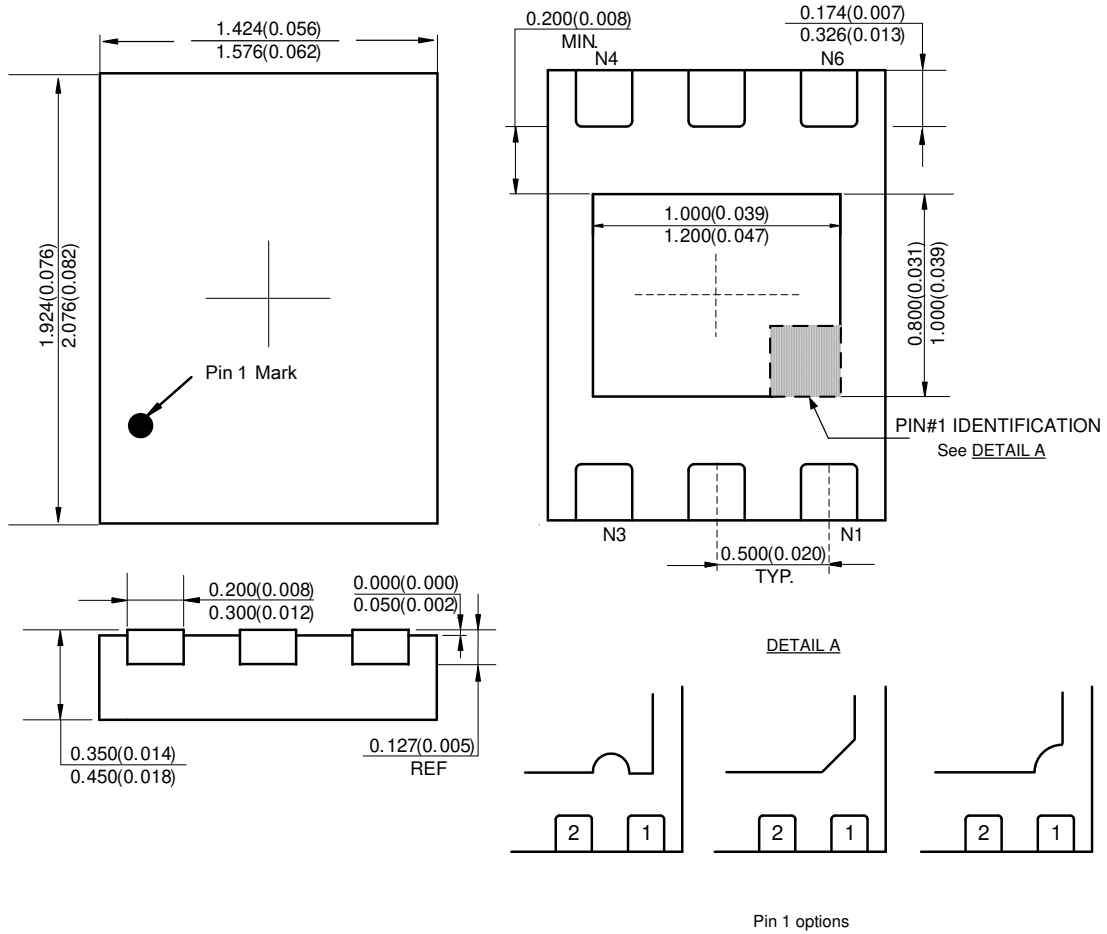

IMPORTANT NOTICE

DIODES INCORPORATED MAKES NO WARRANTY OF ANY KIND, EXPRESS OR IMPLIED, WITH REGARDS TO THIS DOCUMENT, INCLUDING, BUT NOT LIMITED TO, THE IMPLIED WARRANTIES OF MERCHANTABILITY AND FITNESS FOR A PARTICULAR PURPOSE (AND THEIR EQUIVALENTS UNDER THE LAWS OF ANY JURISDICTION).

Diodes Incorporated and its subsidiaries reserve the right to make modifications, enhancements, improvements, corrections or other changes without further notice to this document and any product described herein. Diodes Incorporated does not assume any liability arising out of the application or use of this document or any product described herein; neither does Diodes Incorporated convey any license under its patent or trademark rights, nor the rights of others. Any Customer or user of this document or products described herein in such applications shall assume all risks of such use and will agree to hold Diodes Incorporated and all the companies whose products are represented on Diodes Incorporated website, harmless against all damages.

Diodes Incorporated does not warrant or accept any liability whatsoever in respect of any products purchased through unauthorized sales channel. Should Customers purchase or use Diodes Incorporated products for any unintended or unauthorized application, Customers shall indemnify and hold Diodes Incorporated and its representatives harmless against all claims, damages, expenses, and attorney fees arising out of, directly or indirectly, any claim of personal injury or death associated with such unintended or unauthorized application.

Products described herein may be covered by one or more United States, international or foreign patents pending. Product names and markings noted herein may also be covered by one or more United States, international or foreign trademarks.

This document is written in English but may be translated into multiple languages for reference. Only the English version of this document is the final and determinative format released by Diodes Incorporated.

LIFE SUPPORT

Diodes Incorporated products are specifically not authorized for use as critical components in life support devices or systems without the express written approval of the Chief Executive Officer of Diodes Incorporated. As used herein:

A. Life support devices or systems are devices or systems which:

1. are intended to implant into the body, or
2. support or sustain life and whose failure to perform when properly used in accordance with instructions for use provided in the labeling can be reasonably expected to result in significant injury to the user.

B. A critical component is any component in a life support device or system whose failure to perform can be reasonably expected to cause the failure of the life support device or to affect its safety or effectiveness.

Customers represent that they have all necessary expertise in the safety and regulatory ramifications of their life support devices or systems, and acknowledge and agree that they are solely responsible for all legal, regulatory and safety-related requirements concerning their products and any use of Diodes Incorporated products in such safety-critical, life support devices or systems, notwithstanding any devices- or systems-related information or support that may be provided by Diodes Incorporated. Further, Customers must fully indemnify Diodes Incorporated and its representatives against any damages arising out of the use of Diodes Incorporated products in such safety-critical, life support devices or systems.

Copyright © 2018, Diodes Incorporated

www.diodes.com