

# DP83865

*DP83865 Gig PHYTER V 10/100/1000 Ethernet Physical Layer*



Literature Number: SNLS165B

# DP83865 Gig PHYTER® V

## 10/100/1000 Ethernet Physical Layer

### General Description

The DP83865 is a fully featured Physical Layer transceiver with integrated PMD sublayers to support 10BASE-T, 100BASE-TX and 1000BASE-T Ethernet protocols.

The DP83865 is an ultra low power version of the DP83861 and DP83891. It uses advanced 0.18 um, 1.8 V CMOS technology, fabricated at National Semiconductor's South Portland, Maine facility.

The DP83865 is designed for easy implementation of 10/100/1000 Mb/s Ethernet LANs. It interfaces directly to Twisted Pair media via an external transformer. This device interfaces directly to the MAC layer through the IEEE 802.3u Standard Media Independent Interface (MII), the IEEE 802.3z Gigabit Media Independent Interface (GMII), or Reduced GMII (RGMII).

The DP83865 is a fourth generation Gigabit PHY with field proven architecture and performance. Its robust performance ensures drop-in replacement of existing 10/100 Mbps equipment with ten to one hundred times the performance using the existing networking infrastructure.

### Applications

The DP83865 fits applications in:

- 10/100/1000 Mb/s capable node cards
- Switches with 10/100/1000 Mb/s capable ports
- High speed uplink ports (backbone)

### Features

- Ultra low power consumption typically 1.1 watt
- Fully compliant with IEEE 802.3 10BASE-T, 100BASE-TX and 1000BASE-T specifications

- Integrated PMD sublayer featuring adaptive equalization and baseline wander compensation according to ANSI X3.T12
- 3.3 V or 2.5 V MAC interfaces:
- IEEE 802.3u MII
- IEEE 802.3z GMII
- RGMII version 1.3
- User programmable GMII pin ordering
- IEEE 802.3u Auto-Negotiation and Parallel Detection
- Fully Auto-Negotiates between 1000 Mb/s, 100 Mb/s, and 10 Mb/s full duplex and half duplex devices
- Speed Fallback mode to achieve quality link
- Cable length estimator
- LED support for activity, full / half duplex, link1000, link100 and link10, user programmable (manual on/off), or reduced LED mode
- Supports 25 MHz operation with crystal or oscillator.
- Requires only two power supplies, 1.8 V (core and analog) and 2.5 V (analog and I/O). 3.3V is supported as an alternative supply for I/O voltage
- User programmable interrupt
- Supports Auto-MDIX at 10, 100 and 1000 Mb/s
- Supports JTAG (IEEE1149.1)
- 128-pin PQFP package (14mm x 20mm)

### SYSTEM DIAGRAM

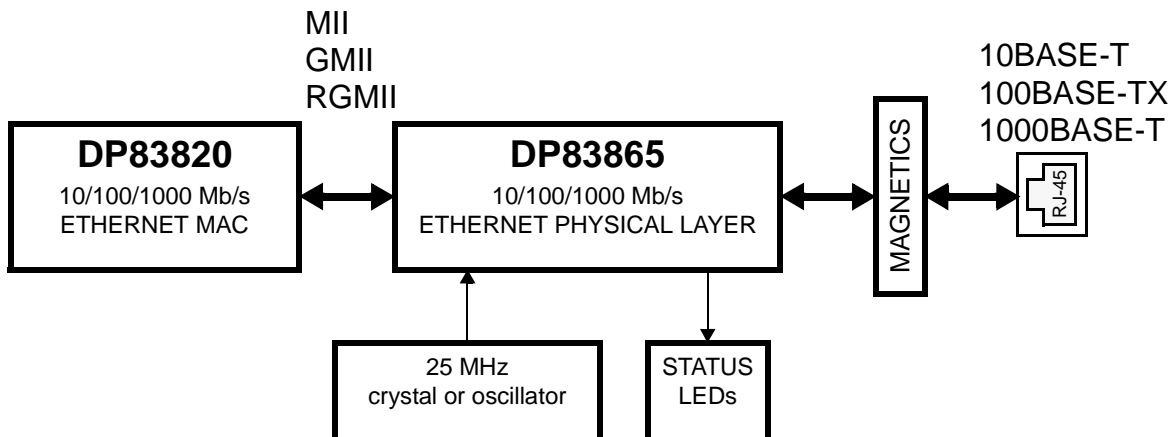

PHYTER® is a registered trademark of National Semiconductor Corporation

Block Diagram

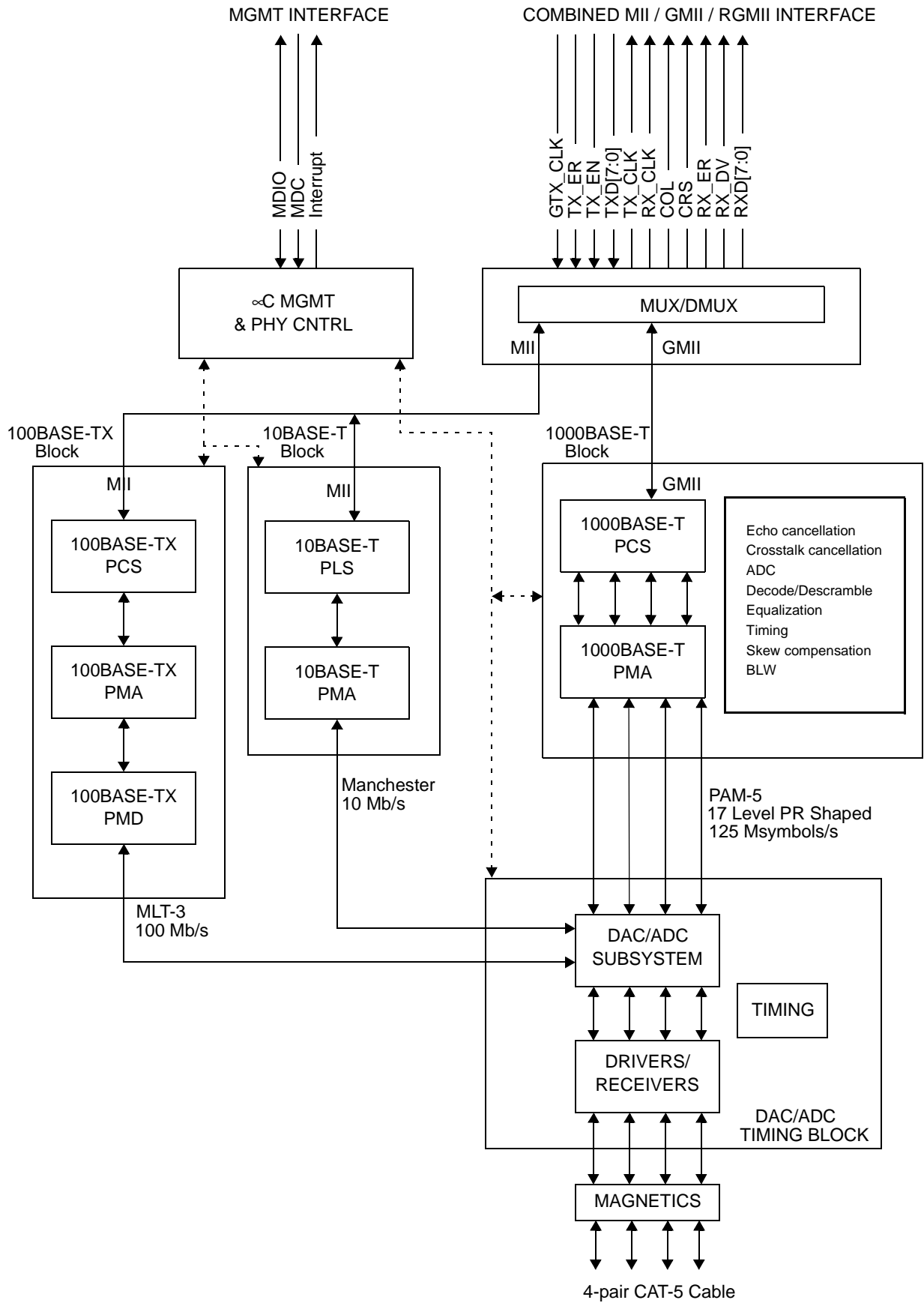

## Table of Contents

<b>1.0</b>	<b>Pin Description</b>	<b>5</b>	<b>6.0</b>	<b>Electrical Specifications</b>	<b>71</b>
1.1	MAC Interfaces (MII, GMII, and RGMII)	5	6.1	DC Electrical Specification	71
1.2	Management Interface	7	6.2	Reset Timing	73
1.3	Media Dependent Interface	7	6.3	Clock Timing	74
1.4	JTAG Interface	7	6.4	1000 Mb/s Timing	74
1.5	Clock Interface	8	6.5	RGMII Timing	76
1.6	Device Configuration and LED Interface	8	6.6	100 Mb/s Timing	77
1.7	Reset	10	6.7	10 Mb/s Timing	78
1.8	Power and Ground Pins	11	6.8	Loopback Timing	79
1.9	Special Connect Pins	11	6.9	Serial Management Interface Timing	80
1.10	Pin Assignments in the Pin Number Order	12	6.10	Power Consumption	81
<b>2.0</b>	<b>Register Block</b>	<b>18</b>	<b>7.0</b>	<b>Frequently Asked Questions</b>	<b>82</b>
2.1	Register Definitions	18	7.1	Do I need to access any MDIO register to start up the PHY?	82
2.2	Register Map	19	7.2	I am trying to access the registers through MDIO and I got invalid data. What should I do?	82
2.3	Register Description	21	7.3	Why can the PHY establish a valid link but can not transmit or receive data?	82
<b>3.0</b>	<b>Configuration</b>	<b>40</b>	7.4	What is the difference between TX_CLK, TX_TCLK, and GTX_CLK?	82
3.1	Accessing Expanded Memory Space	40	7.5	What happens to the TX_CLK during 1000 Mbps operation? Similarly what happens to RXD[4:7] during 10/100 Mbps operation?	82
3.2	Manual Configuration	40	7.6	What happens to the TX_CLK and RX_CLK during Auto-Negotiation and during idles?	82
3.3	Auto-Negotiation	41	7.7	Why doesn't the Gig PHYTER V complete Auto-Negotiation if the link partner is a forced 1000 Mbps PHY?	82
3.4	Auto-Negotiation Register Set	44	7.8	What determines Master/Slave mode when Auto-Negotiation is disabled in 1000Base-T mode?	82
3.5	Auto-MDIX resolution	44	7.9	How long does Auto-Negotiation take?	83
3.6	Polarity Correction	45	7.10	How do I measure FLP's?	83
3.7	PHY Address, Strapping Options and LEDs	45	7.11	I have forced 10 Mbps or 100 Mbps operation but the associated speed LED doesn't come on.	83
3.8	Reduced LED Mode	45	7.12	I know I have good link, but register 0x01, bit 2 "Link Status" doesn't contain value '1' indicating good link.	83
3.9	Modulate LED on Error	45	7.13	Your reference design shows pull-up or pull-down resistors attached to certain pins, which conflict with the pull-up or pull-down information specified in the datasheet?	83
3.10	MAC Interface	45	7.14	How is the maximum package case temperature calculated?	83
3.11	Clock to MAC Enable	46	7.15	The DP83865 will establish Link in 100 Mbps mode with a Broadcom part, but it will not establish link in 1000 Mbps mode. When this happens the DP83865's Link LED will blink on and off.	83
3.12	MII/GMII/RGMII Isolate Mode	46	7.16	How do I quickly determine the quality of the link over the cable ?	83
3.13	Loopback Mode	46	7.17	What is the power up sequence for DP83865?	83
3.14	IEEE 802.3ab Test Modes	46	7.18	What are some other applicable documents?	84
3.15	Interrupt	47	<b>8.0</b>	<b>Physical Dimensions</b>	<b>86</b>
3.16	Low Power Mode / WOL	47			
3.17	Power Down Mode	47			
3.18	BIST Configuration	47			
3.19	Cable Length Indicator	48			
3.20	10BASE-T Half Duplex Loopback	48			
3.21	I/O Voltage Selection	48			
3.22	Non-compliant inter-operability mode	48			
<b>4.0</b>	<b>Functional Description</b>	<b>49</b>			
4.1	1000BASE-T PCS Transmitter	49			
4.2	1000BASE-T PMA Transmitter	50			
4.3	1000BASE-T PMA Receiver	50			
4.4	1000BASE-T PCS Receiver	51			
4.5	Gigabit MII (GMII)	52			
4.6	Reduced GMII (RGMII)	53			
4.7	10BASE-T and 100BASE-TX Transmitter	54			
4.8	10BASE-T and 100BASE-TX Receiver	57			
4.9	Media Independent Interface (MII)	60			
<b>5.0</b>	<b>Design Guide</b>	<b>63</b>			
5.1	Hardware Reset	63			
5.2	Clocks	63			
5.3	Power Supply Decoupling	64			
5.4	Sensitive Supply Pins	64			
5.5	PCB Layer Stacking	64			
5.6	Layout Notes on MAC Interface	66			
5.7	Twisted Pair Interface	66			
5.8	RJ-45 Connections	67			
5.9	LED/Strapping Option	67			
5.10	Unused Pins and Reserved Pins	67			
5.11	I/O Voltage Considerations	68			
5.12	Power-up Recommendations	68			
5.13	Component Selection	68			

PQFP Pin Layout

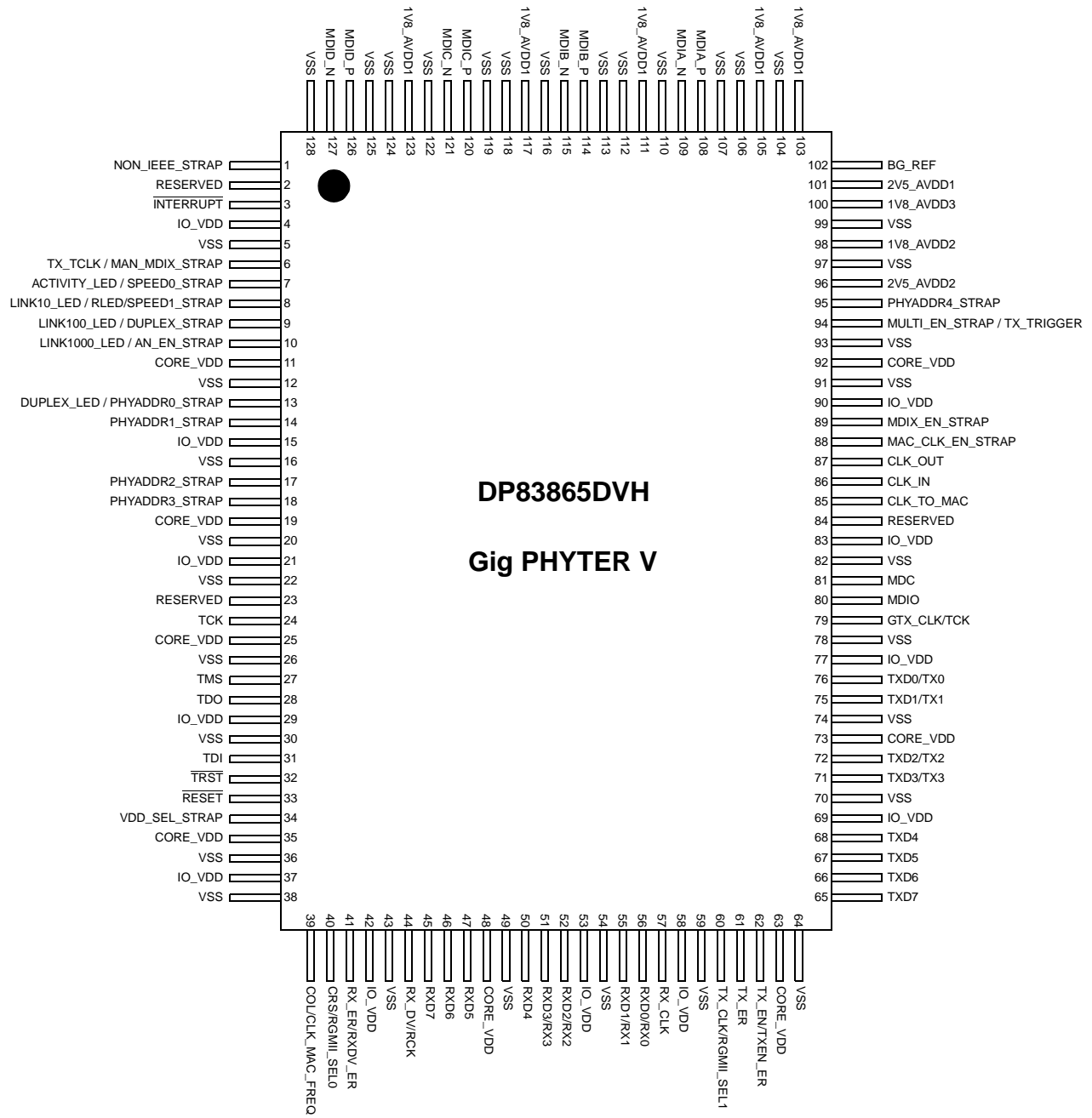

Figure 1. DP83865 Pinout  
Order Part Number: DP83865DVH

## 1.0 Pin Description

The DP83865 pins are classified into the following interface categories (each is described in the sections that follow):

— MAC Interfaces	Type: I	Inputs
— Management Interface	Type: O	Output
— Media Dependent Interface	Type: O_Z	Tristate Output
— JTAG Interface	Type: I/O_Z	Tristate Input_Output
— Clock Interface	Type: S	Strapping Pin
— Device Configuration and LED Interface	Type: PU	Internal Pull-up
— Reset	Type: PD	Internal Pull-down
— Power and Ground Pins		
— Special Connect Pins		

### 1.1 MAC Interfaces (MII, GMII, and RGMII)

Signal Name	Type	PQFP Pin #	Description															
CRS/RGMII_SEL0	O_Z, S, PD	40	<p><b>CARRIER SENSE or RGMII SELECT:</b> CRS is asserted high to indicate the presence of a carrier due to receive or transmit activity in Half Duplex mode. For 10BASE-T and 100BASE-TX Full Duplex operation CRS is asserted when a received packet is detected. This signal is not defined for 1000BASE-T Full Duplex mode.</p> <p>In RGMII mode, the CRS is not used. This pin can be used as a RGMII strapping selection pin.</p> <table border="1"> <thead> <tr> <th><u>RGMII_SEL1</u></th> <th><u>RGMII_SEL0</u></th> <th><u>MAC Interface</u></th> </tr> </thead> <tbody> <tr> <td>0</td> <td>0</td> <td>= GMII</td> </tr> <tr> <td>0</td> <td>1</td> <td>= GMII</td> </tr> <tr> <td>1</td> <td>0</td> <td>= RGMII - HP</td> </tr> <tr> <td>1</td> <td>1</td> <td>= RGMII - 3COM</td> </tr> </tbody> </table>	<u>RGMII_SEL1</u>	<u>RGMII_SEL0</u>	<u>MAC Interface</u>	0	0	= GMII	0	1	= GMII	1	0	= RGMII - HP	1	1	= RGMII - 3COM
<u>RGMII_SEL1</u>	<u>RGMII_SEL0</u>	<u>MAC Interface</u>																
0	0	= GMII																
0	1	= GMII																
1	0	= RGMII - HP																
1	1	= RGMII - 3COM																
COL/CLK_MAC_FREQ	O_Z, S, PD	39	<p><b>COLLISION DETECT:</b> Asserted high to indicate detection of a collision condition (assertion of CRS due to simultaneous transmit and receive activity) in Half Duplex modes. This signal is not synchronous to either MII clock (GTX_CLK, TX_CLK or RX_CLK). This signal is not defined and stays low for Full Duplex modes.</p> <p><b>CLOCK TO MAC FREQUENCY Select:</b>            1 = CLOCK TO MAC output is 125 MHz            0 = CLOCK TO MAC output is 25 MHz</p>															
TX_CLK/RGMII_SEL1	O_Z, S, PD	60	<p><b>TRANSMIT CLOCK or RGMII SELECT:</b> TX_CLK is a continuous clock signal generated from reference CLK_IN and driven by the PHY during 10 Mbps or 100 Mbps MII mode. TX_CLK clocks the data or error out of the MAC layer and into the PHY.</p> <p>The TX_CLK clock frequency is 2.5 MHz in 10BASE-T and 25 MHz in 100BASE-TX mode.</p> <p>Note: "TX_CLK" should not be confused with the "TX_TCLK" signal.</p> <p>In RGMII mode, the TX_CLK is not used. This pin can be used as a RGMII strapping selection pin. This pin should be pulled high for RGMII interface.</p>															

## 1.0 Pin Description (Continued)

Signal Name	Type	PQFP Pin #	Description
TXD0/TX0 TXD1/TX1 TXD2/TX2 TXD3/TX3 TXD4 TXD5 TXD6 TXD7	I	76 75 72 71 68 67 66 65	<b>TRANSMIT DATA:</b> These signals carry 4B data nibbles (TXD[3:0]) during 10 Mbps and 100 Mbps MII mode, 4-bit data (TX[3:0]) in RGMII mode, and 8-bit data (TXD[7:0]) in 1000 Mbps GMII mode. They are synchronous to the transmit clocks (TX_CLK, TCK, GTX_CLK).  Transmit data is input to PHY. In MII or GMII mode, the transmit data is enabled by TX_EN. In RGMII mode, the transmit data is enabled by TXEN_ER.
TX_EN/TXEN_ER	I	62	<b>TRANSMIT ENABLE or TRANSMIT ENABLE/ERROR:</b> In MII or GMII mode, it is an active high input sourced from MAC layer to indicate transmission data is available on the TXD.  In RGMII mode, it combines the transmit enable and the transmit error signals of GMII mode using both clock edges.
GTX_CLK/TCK	I	79	<b>GMII and RGMII TRANSMIT CLOCK:</b> This continuous clock signal is sourced from the MAC layer to the PHY. Nominal frequency is 125 MHz.
TX_ER	I	61	<b>TRANSMIT ERROR:</b> It is an active high input used in MII mode and GMII mode forcing the PHY to transmit invalid symbols. The TX_ER signal is synchronous to the transmit clocks (TX_CLK or GTX_CLK).  In MII 4B nibble mode, assertion of Transmit Error by the controller causes the PHY to issue invalid symbols followed by Halt (H) symbols until deassertion occurs.  In GMII mode, assertion causes the PHY to emit one or more code-groups that are invalid data or delimiter in the transmitted frame.  This signal is not used in the RGMII mode.
RX_CLK	O_Z	57	<b>RECEIVE CLOCK:</b> Provides the recovered receive clocks for different modes of operation: 2.5 MHz in 10 Mbps mode. 25 MHz in 100 Mbps mode. 125 MHz in 1000 Mps GMII mode.  This pin is not used in the RGMII mode.
RXD0/RX0 RXD1/RX1 RXD2/RX2 RXD3/RX3 RXD4 RXD5 RXD6 RXD7	O_Z	56 55 52 51 50 47 46 45	<b>RECEIVE DATA:</b> These signals carry 4-bit data nibbles (RXD[3:0]) during 10 Mbps and 100 Mbps MII mode and 8-bit data bytes (RXD[7:0]) in 1000 Mbps GMII mode. RXD is synchronous to the receive clock (RX_CLK). Receive data is sourced from the PHY to the MAC layer.  Receive data RX[3:0] is used in RGMII mode. The data is synchronous to the RGMII receive clock (RCK). The receive data available (RXDV_EN) indicates valid received data to the MAC layer.
RX_ER/RXDV_ER	O_Z	41	<b>RECEIVE ERROR or RECEIVE DATA AVAILABLE/ERROR:</b> In 10 Mbps, 100 Mbps and 1000 Mbps mode this active high output indicates that the PHY has detected a Receive Error. The RX_ER signal is synchronous with the receive clock (RX_CLK).  In RGMII mode, the receive data available and receive error is combined (RXDV_ER) using both rising and falling edges of the receive clock (RCK).
RX_DV/RCK	O_Z	44	<b>RECEIVE DATA VALID or RECEIVE CLOCK:</b> In MII and GMII modes, it is asserted high to indicate that valid data is present on the corresponding RXD[3:0] in MII mode and RXD[7:0] in GMII mode.  In RGMII mode, this pin is the recovered receive clock (125MHz).

## 1.0 Pin Description (Continued)

### 1.2 Management Interface

Signal Name	Type	PQFP Pin #	Description
MDC	I	81	<b>MANAGEMENT DATA CLOCK:</b> Synchronous clock to the MDIO serial management input/output data. This clock may be asynchronous to the MAC transmit and receive clocks. The maximum clock rate is 2.5 MHz and no minimum.
MDIO	I/O	80	<b>MANAGEMENT DATA I/O:</b> Bi-directional management instruction/data signal that may be sourced by the management station or the PHY. This pin requires a 2k $\Omega$ pullup resistor.
$\overline{\text{INTERRUPT}}$	O_Z, PU	3	<b>MANAGEMENT INTERRUPT:</b> It is an active-low open drain output indicating to the MAC layer or to a management interface that an interrupt has requested. The interrupt status can be read through the Interrupt Status Register. (See section "3.15 Interrupt" on page 47.)  If used this pin requires a 2k $\Omega$ pullup resistor. This pin is to be left floating if it is not used.

### 1.3 Media Dependent Interface

Signal Name	Type	PQFP Pin #	Description
MDIA_P	I/O	108	<b>Media Dependent Interface:</b> Differential receive and transmit signals.  The TP Interface connects the DP83865 to the CAT-5 cable through a single common magnetics transformer. These differential inputs and outputs are configurable to 10BASE-T, 100BASE-TX or 1000BASE-T signalling:  The DP83865 will automatically configure the driver outputs for the proper signal type as a result of either forced configuration or Auto-Negotiation. The automatic MDI / MDIX configuration allows for transmit and receive channel configuration and polarity configuration between channels A and B, and C and D.  <b>NOTE:</b> During 10/100 Mbps operation only MDIA_P, MDIA_N, MDIB_P and MDIB_N are active. MDIA_P and MDIA_N are transmitting only and MDIB_P and MDIB_N are receiving only. (See section "3.5 Auto-MDIX resolution" on page 44)
MDIA_N		109	
MDIB_P		114	
MDIB_N		115	
MDIC_P		120	
MDIC_N		121	
MDID_P		126	
MDID_N		127	

### 1.4 JTAG Interface

Signal Name	Type	PQFP Pin #	Description
$\overline{\text{TRST}}$	I, PD	32	<b>TEST RESET:</b> IEEE 1149.1 Test Reset pin, active low reset provides for asynchronous reset of the Tap Controller. This reset has no effect on the device registers.  This pin should be pulled down through a 2k $\Omega$ resistor if not used.
TDI	I, PU	31	<b>TEST DATA INPUT:</b> IEEE 1149.1 Test Data Input pin, test data is scanned into the device via TDI.  This pin should be left floating if not used.
TDO	O	28	<b>TEST DATA OUTPUT:</b> IEEE 1149.1 Test Data Output pin, the most recent test results are scanned out of the device via TDO.  This pin should be left floating if not used.
TMS	I, PU	27	<b>TEST MODE SELECT:</b> IEEE 1149.1 Test Mode Select pin, the TMS pin sequences the Tap Controller (16-state FSM) to select the desired test instruction.  This pin should be left floating if not used.



## 1.0 Pin Description (Continued)

Signal Name	Type	PQFP Pin #	Description
TCK	I	24	<b>TEST CLOCK:</b> IEEE 1149.1 Test Clock input, primary clock source for all test logic input and output controlled by the testing entity. This pin should be left floating if not used.

## 1.5 Clock Interface

Signal Name	Type	PQFP Pin #	Description
CLK_IN	I	86	<b>CLOCK INPUT:</b> 25 MHz oscillator or crystal input (50 ppm).
CLK_OUT	O	87	<b>CLOCK OUTPUT:</b> Second terminal for 25 MHz crystal. Must be left floating if a clock oscillator is used.
CLK_TO_MAC	O	85	<b>CLOCK TO MAC OUTPUT:</b> This clock output can be used to drive the clock input of a MAC or switch device. This output is available after power-up and is active during all modes except during hardware or software reset. Note that the clock frequency is selectable through CLK_MAC_FREQ between 25 MHz and 125 MHz. To disable this clock output the MAC_CLK_EN_STRAP pin has to be tied low.

## 1.6 Device Configuration and LED Interface

(See section “3.7 PHY Address, Strapping Options and LEDs” on page 45 and section “5.9 LED/Strapping Option” on page 67.)

Signal Name	Type	PQFP Pin #	Description
NON_IEEE_STRAP	I/O, S, PD	1	<b>NON IEEE COMPLIANT MODE ENABLE:</b> This mode allows interoperability with certain non IEEE compliant 100BASE-T transceivers. ‘1’ enables IEEE compliant operation and non-compliant operation ‘0’ enables IEEE compliant operation but inhibits non-compliant operation Note: The status of this bit is reflected in bit 10 of register 0x10. This pin also sets the default for and can be overwritten by bit 9 of register 0x12.
MAN_MDIX_STRAP / TX_TCLK	I/O, S, PD	6	<b>MANUAL MDIX SETTING:</b> This pin sets the default for manual MDI/MDIX configuration. ‘1’ PHY is manually set to cross-over mode (MDIX) ‘0’ PHY is manually set to straight mode (MDI) Note: The status of this bit is reflected in bit 8 of register 0x10. This pin also sets the default for and can be overwritten by bit 14 of register 0x12. <b>TX_TCLK:</b> TX_TCLK is enabled by setting bit 7 of register 0x12. It is used to measure jitter in Test Modes 2 and 3 as described in IEEE 802.3ab specification. TX_TCLK should not be confused with the TX_CLK signal. See Table 12 on page 29 regarding Test Mode setting. This pin should be left floating if not used.

## 1.0 Pin Description (Continued)

Signal Name	Type	PQFP Pin #	Description																														
ACTIVITY_LED / SPEED0_STRAP	I/O, S, PD	7	<p><b>SPEED SELECT STRAP:</b> These strap option pins have 2 different functions depending on whether Auto-Negotiation is enabled or not.</p> <p><u>Auto-Neg disabled:</u></p> <table border="1"> <thead> <tr> <th>Speed[1]</th> <th>Speed[0]</th> <th>Speed Enabled</th> </tr> </thead> <tbody> <tr> <td>1</td> <td>1</td> <td>= Reserved</td> </tr> <tr> <td>1</td> <td>0</td> <td>= 1000BASE-T</td> </tr> <tr> <td>0</td> <td>1</td> <td>= 100BASE-TX</td> </tr> <tr> <td>0</td> <td>0</td> <td>= 10BASE-T</td> </tr> </tbody> </table> <p><u>Auto-Neg enabled (Advertised capability):</u></p> <table border="1"> <thead> <tr> <th>Speed[1]</th> <th>Speed[0]</th> <th>Speed Enabled</th> </tr> </thead> <tbody> <tr> <td>1</td> <td>1</td> <td>= 1000BASE-T, 10BASE-T</td> </tr> <tr> <td>1</td> <td>0</td> <td>= 1000BASE-T</td> </tr> <tr> <td>0</td> <td>1</td> <td>= 1000BASE-T, 100BASE-TX</td> </tr> <tr> <td>0</td> <td>0</td> <td>= 1000BASE-T, 100BASE-TX, 10BASE-T</td> </tr> </tbody> </table> <p>Note: The status of this bit is reflected in register 0x10.12.</p> <p><b>ACTIVITY LED:</b> The LED output indicates the occurrence of either idle error or packet transfer.</p>	Speed[1]	Speed[0]	Speed Enabled	1	1	= Reserved	1	0	= 1000BASE-T	0	1	= 100BASE-TX	0	0	= 10BASE-T	Speed[1]	Speed[0]	Speed Enabled	1	1	= 1000BASE-T, 10BASE-T	1	0	= 1000BASE-T	0	1	= 1000BASE-T, 100BASE-TX	0	0	= 1000BASE-T, 100BASE-TX, 10BASE-T
Speed[1]	Speed[0]	Speed Enabled																															
1	1	= Reserved																															
1	0	= 1000BASE-T																															
0	1	= 100BASE-TX																															
0	0	= 10BASE-T																															
Speed[1]	Speed[0]	Speed Enabled																															
1	1	= 1000BASE-T, 10BASE-T																															
1	0	= 1000BASE-T																															
0	1	= 1000BASE-T, 100BASE-TX																															
0	0	= 1000BASE-T, 100BASE-TX, 10BASE-T																															
LINK10_LED /RLED/ SPEED1_STRAP	I/O, S, PD	8	<p><b>SPEED SELECT STRAP:</b> The strap option pins have 2 different functions depending on whether Auto-Neg is enabled or not. See SPEED0_STRAP for details.</p> <p>Note: The status of this bit is reflected in register 0x10.13.</p> <p><b>10M GOOD LINK LED:</b> In the standard 5-LED display mode, this LED output indicates that the PHY has established a good link at 10 Mbps.</p> <p><b>RLED MODE:</b> There are two reduced LED modes, the 3-in-1 and 4-in-1 modes. Each RLED mode is enabled in register 0x13.5 and 0x1A.0.</p> <ul style="list-style-type: none"> <li>- 3-in-1: 10, 100, and 1000 Mbps good links are combined into one LED.</li> <li>- 4-in-1: 3-in-1 and activity are combined.</li> </ul> <p>Note: LED steady on indicates good link and flashing indicates Tx/Rx activities.</p>																														
LINK100_LED / DUPLEX_STRAP	I/O, S, PU	9	<p><b>DUPLEX MODE:</b> This pin sets the default value for the duplex mode. '1' enables Full Duplex by default, '0' enables Half Duplex only.</p> <p>Note: The status of this bit is reflected in bit 14 of register 0x10.</p> <p><b>100M SPEED AND GOOD LINK LED:</b> The LED output indicates that the PHY has established a good link at 100 Mbps.</p> <p>In 100BASE-T mode, the link is established as a result of an input receive amplitude compliant with TP-PMD specifications which will result in internal generation of Signal Detect. LINK100_LED will assert after the internal Signal Detect has remained asserted for a minimum of 500 <math>\mu</math>s. LINK100_LED will de-assert immediately following the de-assertion of the internal Signal Detect.</p>																														
LINK1000_LED / AN_EN_STRAP	I/O, S, PU	10	<p><b>AUTO-NEGOTIATION ENABLE:</b> Input to initialize Auto-Negotiation Enable bit (register 0 bit-12).</p> <p>'1' enables Auto-Neg and '0' disables Auto-Neg.</p> <p>Note: The status of this bit is reflected in bit 15 of register 0x10. This pin also sets the default for and can be overwritten by bit 12 of register 0x00.</p> <p><b>1000M SPEED AND GOOD LINK LED:</b> The LED output indicates that the PHY has established a good link at 1000 Mbps.</p> <p>In 1000BASE-T mode, the link is established as a result of training, Auto-Negotiation completed, valid 1000BASE-T link established and reliable reception of signals transmitted from a remote PHY is received.</p>																														

## 1.0 Pin Description (Continued)

Signal Name	Type	PQFP Pin #	Description
DUPLEX_LED / PHYADDR0_STRAP	I/O, S, PU	13	<p><b>PHY ADDRESS [4:0]:</b> The DP83865 provides five PHY address-sensing pins for multiple PHY applications. The setting on these five pins provides the base address of the PHY.</p> <p>The five PHYAD[4:0] bits are registered as inputs at reset with PHYADDR4 being the MSB of the 5-bit PHY address.</p> <p>Note: The status of these bit is reflected in bits 4:0 of register 0x12.</p> <p><b>DUPLEX STATUS:</b> The LED is lit when the PHY is in Full Duplex operation after the link is established.</p>
PHYADDR1_STRAP	PD	14	
PHYADDR2_STRAP	PD	17	
PHYADDR3_STRAP	PD	18	
PHYADDR4_STRAP	PD	95	
MULTI_EN_STRAP / TX_TRIGGER	I/O, S, PD	94	<p><b>MULTIPLE NODE ENABLE:</b> This pin determines if the PHY advertises Master (multiple nodes) or Slave (single node) priority during 1000BASE-T Auto-Negotiation.</p> <p>'1' Selects multiple node priority (switch or hub) '0' Selects single node priority (NIC)</p> <p>Note: The status of this bit is reflected in bit 5 of register 0x10.</p> <p><b>TX_TRIGGER:</b> This output can be enabled during the IEEE 1000BASE-T test-modes. This signal is not required by IEEE to perform the tests, but will help to take measurements. TX_TRIGGER is only available in test modes 1 and 4 and provides a trigger to allow for viewing test waveforms on an oscilloscope.</p>
MDIX_EN_STRAP	I/O, S, PU	89	<p><b>AUTO MDIX ENABLE:</b> This pin controls the automatic pair swap (Auto-MDIX) of the MDI/MDIX interface.</p> <p>'1' enables pair swap mode '0' disables the Auto-MDIX and defaults the part into the mode preset by the MAN_MDIX_STRAP pin.</p> <p>Note: The status of this bit is reflected in bit 6 of register 0x10. This pin also sets the default for and can be overwritten by bit 15 of register 0x12.</p>
MAC_CLK_EN_STRAP / TX_SYN_CLK	I, S, PU	88	<p><b>CLOCK TO MAC ENABLE:</b></p> <p>'1' CLK_TO_MAC clock output enabled '0' CLK_TO_MAC disabled</p> <p>Note: This status of this pin is reflected in bit 7 of register 0x10.</p> <p><b>TX_SYN_CLK:</b> This output can be enabled during the IEEE 1000BASE-T test-modes. This signal is not required by IEEE to perform the tests, but will help to take measurements. TX_SYN_CLK is only available in test modes 1 and 4.</p> <p>TX_SYN_CLK = TX_TCLK / 4 in test mode 1 TX_SYN_CLK = TX_TCLK / 6 in test mode 4</p>
VDD_SEL_STRAP	I/O, S	34	<p><b>IO_VDD SELECT:</b> This pin selects between 2.5V or 3.3V for I/O VDD .</p> <p>'1' selects 3.3V mode '0' selects 2.5V mode</p> <p>This pin must either be connected directly to ground or directly to a supply voltage (2.5V to 3.3V).</p>

## 1.7 Reset

Signal Name	Type	PQFP Pin #	Description
RESET	I	33	<p><b>RESET:</b> The active low RESET input allows for hard-reset, soft-reset, and TRI-STATE output reset combinations. The RESET input must be low for a minimum of 150 ns.</p>

## 1.0 Pin Description (Continued)

### 1.8 Power and Ground Pins

(See section “5.3 Power Supply Decoupling” on page 64.)

Signal Name	PQFP Pin #	Description
IO_VDD	4, 15, 21, 29, 37, 42, 53, 58, 69, 77, 83, 90	2.5V or 3.3V I/O Supply for “MAC Interfaces”, “Management Interface”, “JTAG Interface”, “Clock Interface”, “Device Configuration and LED Interface” and “Reset”.
CORE_VDD	11, 19, 25, 35, 48, 63, 73, 92	1.8V Digital Core Supply
2V5_AVDD1	101	2.5V Analog Supply
2V5_AVDD2	96	2.5V Analog Supply
1V8_AVDD1	103, 105, 111, 117, 123	1.8V Analog Supply
1V8_AVDD2	98	1.8V Analog Supply - See section “5.4 Sensitive Supply Pins” on page 64 for low pass filter recommendation.
1V8_AVDD3	100	1.8V Analog Supply - See section “5.4 Sensitive Supply Pins” on page 64 for low pass filter recommendation.
VSS	5, 12, 16, 20, 22, 26, 30, 36, 38, 43, 49, 54, 59, 64, 70, 74, 78, 82, 91, 93, 97, 99, 104, 106, 107, 110, 112, 113, 116, 118, 119, 122, 124, 125, 128	Ground

### 1.9 Special Connect Pins

Signal Name	TYPE	PQFP Pin #	Description
BG_REF	I	102	<b>Internal Reference Bias:</b> See section “5.4 Sensitive Supply Pins” on page 64 for information on how to terminate this pin.
RESERVED		2, 23, 84	These pins are reserved and must be left floating.

## 1.0 Pin Description (Continued)

### 1.10 Pin Assignments in the Pin Number Order

Table 1.

Pin #	Data Sheet Pin Name	Type	Connection / Comment
1	NON_IEEE_STRAP	Strap	<b>Non IEEE Compliant Mode Enable:</b> Use a 2k $\Omega$ pull-up resistor to enable. Leave open to disable.
2	RESERVED	Reserved	<b>Reserved:</b> Leave floating.
3	INTERRUPT	Output	<b>INTERRUPT:</b> Connect to MAC or management IC. This is a tri-state pin and requires an external 2k $\Omega$ pull-up resistor if the pin is used.
4	IO_VDD	Power	<b>IO VDD:</b> (Digital) Connect to 2.5V or 3.3V. The VDD_SEL pin must be tied accordingly.
5	VSS	Ground	<b>Ground:</b> Connect to common ground plane.
6	TX_TCLK	Output	<b>Transmit Test Clock:</b> See section "1.9 Special Connect Pins" on page 11.
7	ACTIVITY_LED / SPEED0_STRAP	Strap / Output	<b>Activity LED / SPEED0 Select:</b> See section "5.9 LED/Strapping Option" on page 67 on how to connect this pin for speed selection and ACTIVITY_LED function.
8	LINK10_LED / RLED/SPEED1_STRAP	Strap / Output	<b>10M Link LED / RLED / SPEED1:</b> See section "5.9 LED/Strapping Option" on page 67 on how to connect this pin for speed selection and LINK10_LED function.
9	LINK100_LED / DUPLEX_STRAP	Strap / Output	<b>100M Link LED / Duplex Select:</b> See section "5.9 LED/Strapping Option" on page 67 on how to connect this pin for Duplex selection and 100_LED function.
10	LINK1000_LED / AN_EN_STRAP	Strap / Output	<b>1000M Link LED / Auto-Neg. Select:</b> See section "5.9 LED/Strapping Option" on page 67 on how to connect this pin for Auto-negotiation configuration and 1000_LED function.
11	CORE_VDD	Power	<b>Core VDD:</b> (Digital) Connect to 1.8V.
12	VSS	Ground	<b>Ground:</b> Connect to common ground plane.
13	DUPLEX_LED / PHYADDR0_STRAP	Strap / Output	<b>Duplex LED / PHY Address 0:</b> See section "5.9 LED/Strapping Option" on page 67 on how to connect this pin for PHY address configuration and DUPLEX_LED function.
14	PHYADDR1_STRAP	Strap	<b>PHY Address 1:</b> See section "5.9 LED/Strapping Option" on page 67 on how to connect this pin.
15	IO_VDD	Power	<b>IO VDD:</b> (Digital) Connect to 2.5V or 3.3V. The VDD_SEL pin must be tied accordingly.
16	VSS	Ground	<b>Ground:</b> Connect to common ground plane.
17	PHYADDR2_STRAP	Strap	<b>PHY Address 2:</b> See section "5.9 LED/Strapping Option" on page 67 on how to connect this pin
18	PHYADDR3_STRAP	Strap	<b>PHY Address 3:</b> See section "5.9 LED/Strapping Option" on page 67 on how to connect this pin
19	CORE_VDD	Power	<b>Core VDD:</b> (Digital) Connect to 1.8V.
20	VSS	Ground	<b>Ground:</b> Connect to common ground plane.
21	IO_VDD	Power	<b>IO VDD:</b> (Digital) Connect to 2.5V or 3.3V. The VDD_SEL pin must be tied accordingly.
22	VSS	Ground	<b>Ground:</b> Connect to common ground plane.

## 1.0 Pin Description (Continued)

Table 1.

Pin #	Data Sheet Pin Name	Type	Connection / Comment
23	RESERVED	Reserved	<b>Reserved:</b> Leave floating.
24	TCK	Input	<b>JTAG Test Clock:</b> This pin should be left floating if not used.
25	CORE_VDD	Power	<b>Core VDD:</b> (Digital) Connect to 1.8V.
26	VSS	Ground	<b>Ground:</b> Connect to common ground plane.
27	TMS	Input	<b>JTAG Test Mode Select:</b> This pin should be left floating if not used.
28	TDO	Output	<b>JTAG Test Data Output:</b> This pin should be left floating if not used.
29	IO_VDD	Power	<b>IO VDD:</b> (Digital) Connect to 2.5V or 3.3V. The VDD_SEL pin must be tied accordingly.
30	VSS	Ground	<b>Ground:</b> Connect to common ground plane.
31	TDI	Input	<b>JTAG Test Data Input:</b> This pin should be left floating if not used.
32	$\overline{\text{TRST}}$	Input	<b>JTAG Test Reset:</b> This pin should be pulled down through a 2k $\Omega$ resistor if not used.
33	$\overline{\text{RESET}}$	Input	<b>Reset:</b> Connect to board reset signal.
34	VDD_SEL_STRAP	Strap	<b>I/O VDD Select:</b> Pull high to select 3.3V or low to select 2.5V. The pin must be connected directly to power or ground (no pull-up/down resistor!).
35	CORE_VDD	Power	<b>Core VDD:</b> (Digital) Connect to 1.8V.
36	VSS	Ground	<b>Ground:</b> Connect to common ground plane.
37	IO_VDD	Power	<b>I/O VDD:</b> (Digital) Connect to 2.5V or 3.3V. The VDD_SEL pin must be tied accordingly.
38	VSS	Ground	<b>Ground:</b> Connect to common ground plane.
39	COL	Output	<b>Collision:</b> Connect to MAC chip through a single 50 $\Omega$ impedance trace. This output is capable of driving 35 pF load and is not intended to drive connectors, cables, backplanes or multiple traces. This applies if the part is in 100 Mbps mode or 1000 Mbps mode.
40	CRS/RGMII_SELO	Output	<b>Carrier Sense:</b> Connect to MAC chip through a single 50 $\Omega$ impedance trace. This output is capable of driving 35 pf load and is not intended to drive connectors, cables, backplanes or multiple traces. This applies if the part is in 100 Mbps mode or 1000 Mbps mode.
41	RX_ER/RXDV_ER	Output	<b>Receive Error:</b> Connect to MAC chip through a single 50 $\Omega$ impedance trace. This output is capable of driving 35 pf load and is not intended to drive connectors, cables, backplanes or multiple traces. This applies if the part is in 100 Mbps mode or 1000 Mbps mode.
42	IO_VDD	Power	<b>I/O VDD:</b> (Digital) Connect to 2.5V or 3.3V. The VDD_SEL pin must be tied accordingly.
43	VSS	Ground	<b>Ground:</b> Connect to common ground plane.
44	RX_DV/RCK	Output	<b>Receive Data Valid:</b> Connect to MAC chip through a single 50 $\Omega$ impedance trace. This output is capable of driving 35 pf load and is not intended to drive connectors, cables, backplanes or multiple traces. This applies if the part is in 100 Mbps mode or 1000 Mbps mode.

## 1.0 Pin Description (Continued)

Table 1.

Pin #	Data Sheet Pin Name	Type	Connection / Comment
45	RXD7	Output	<b>Receive Data 7:</b> Connect to MAC chip through a single 50 $\Omega$ impedance trace. This output is capable of driving 35 pf load and is not intended to drive connectors, cables, backplanes or multiple traces. This applies if the part is in 100 Mbps mode or 1000 Mbps mode.
46	RXD6	Output	<b>Receive Data 6:</b> Connect to MAC chip through a single 50 $\Omega$ impedance trace. This output is capable of driving 35 pf load and is not intended to drive connectors, cables, backplanes or multiple traces. This applies if the part is in 100 Mbps mode or 1000 Mbps mode.
47	RXD5	Output	<b>Receive Data 5:</b> Connect to MAC chip through a single 50 $\Omega$ impedance trace. This output is capable of driving 35 pf load and is not intended to drive connectors, cables, backplanes or multiple traces. This applies if the part is in 100 Mbps mode or 1000 Mbps mode.
48	CORE_VDD	Power	<b>Core VDD:</b> (Digital) Connect to 1.8V.
49	VSS	Ground	<b>Ground:</b> Connect to common ground plane.
50	RXD4	Output	<b>Receive Data 4:</b> Connect to MAC chip through a single 50 $\Omega$ impedance trace. This output is capable of driving 35 pf load and is not intended to drive connectors, cables, backplanes or multiple traces. This applies if the part is in 100 Mbps mode or 1000 Mbps mode.
51	RXD3/RX3	Output	<b>Receive Data 3:</b> Connect to MAC chip through a single 50 $\Omega$ impedance trace. This output is capable of driving 35 pf load and is not intended to drive connectors, cables, backplanes or multiple traces. This applies if the part is in 100 Mbps mode or 1000 Mbps mode.
52	RXD2/RX2	Output	<b>Receive Data 2:</b> Connect to MAC chip through a single 50 $\Omega$ impedance trace. This output is capable of driving 35 pf load and is not intended to drive connectors, cables, backplanes or multiple traces. This applies if the part is in 100 Mbps mode or 1000 Mbps mode.
53	IO_VDD	Power	<b>IO VDD:</b> (Digital) Connect to 2.5V or 3.3V. The VDD_SEL pin must be tied accordingly.
54	VSS	Ground	<b>Ground:</b> Connect to common ground plane.
55	RXD1/RX1	Output	<b>Receive Data 1:</b> Connect to MAC chip through a single 50 $\Omega$ impedance trace. This output is capable of driving 35 pf load and is not intended to drive connectors, cables, backplanes or multiple traces. This applies if the part is in 100 Mbps mode or 1000 Mbps mode.
56	RXD0/RX0	Output	<b>Receive Data 0:</b> Connect to MAC chip through a single 50 $\Omega$ impedance trace. This output is capable of driving 35 pf load and is not intended to drive connectors, cables, backplanes or multiple traces. This applies if the part is in 100 Mbps mode or 1000 Mbps mode.

## 1.0 Pin Description (Continued)

Table 1.

Pin #	Data Sheet Pin Name	Type	Connection / Comment
57	RX_CLK	Output	<b>Receive Clock/ Receive Byte Clock 1:</b> Connect to MAC chip through a single 50 $\Omega$ impedance trace. This output is capable of driving 35 pF load and is not intended to drive connectors, cables, backplanes or multiple traces. This applies if the part is in 100 Mbps mode or 1000 Mbps mode.
58	IO_VDD	Power	<b>I/O VDD:</b> (Digital) Connect to 2.5V or 3.3V. The VDD_SEL pin must be tied accordingly.
59	VSS	Ground	<b>Ground:</b> Connect to common ground plane.
60	TX_CLK/RGMII_SEL1	Output	<b>Transmit Clock:</b> Connect to MAC chip through a single 50 $\Omega$ impedance trace. This input has a typical input capacitance of 6 pF.
61	TX_ER	Input	<b>Transmit Error:</b> Connect to MAC chip through a single 50 $\Omega$ impedance trace. This input has a typical input capacitance of 6 pF.
62	TX_EN/TXEN_ER	Input	<b>Transmit Enable:</b> Connect to MAC chip through a single 50 $\Omega$ impedance trace. This input has a typical input capacitance of 6 pF.
63	CORE_VDD	Power	<b>Core VDD:</b> (Digital) Connect to 1.8V.
64	VSS	Ground	<b>Ground:</b> Connect to common ground plane.
65	TXD7	Input	<b>Transmit Data 7:</b> Connect to MAC chip through a single 50 $\Omega$ impedance trace. This input has a typical input capacitance of 6 pF.
66	TXD6	Input	<b>Transmit Data 6:</b> Connect to MAC chip through a single 50 $\Omega$ impedance trace. This input has a typical input capacitance of 6 pF.
67	TXD5	Input	<b>Transmit Data 5:</b> Connect to MAC chip through a single 50 $\Omega$ impedance trace. This input has a typical input capacitance of 6 pF.
68	TXD4	Input	<b>Transmit Data 4:</b> Connect to MAC chip through a single 50 $\Omega$ impedance trace. This input has a typical input capacitance of 6 pF.
69	IO_VDD	Power	<b>I/O VDD:</b> (Digital) Connect to 2.5V or 3.3V. The VDD_SEL pin must be tied accordingly.
70	VSS	Ground	<b>Ground:</b> Connect to common ground plane.
71	TXD3/TX3	Input	<b>Transmit Data 3:</b> Connect to MAC chip through a single 50 $\Omega$ impedance trace. This input has a typical input capacitance of 6 pF.
72	TXD2/TX2	Input	<b>Transmit Data 2:</b> Connect to MAC chip through a single 50 $\Omega$ impedance trace. This input has a typical input capacitance of 6 pF.
73	CORE_VDD	Power	<b>Core VDD:</b> (Digital) Connect to 1.8V.
74	VSS	Ground	<b>Ground:</b> Connect to common ground plane.
75	TXD1/TX1	Input	<b>Transmit Data 1:</b> Connect to MAC chip through a single 50 $\Omega$ impedance trace. This input has a typical input capacitance of 6 pF.
76	TXD0/TX0	Input	<b>Transmit Data 0:</b> Connect to MAC chip through a single 50 $\Omega$ impedance trace. This input has a typical input capacitance of 6 pF.
77	IO_VDD	Power	<b>I/O VDD:</b> (Digital) Connect to 2.5V or 3.3V. The VDD_SEL pin must be tied accordingly.
78	VSS	Ground	<b>Ground:</b> Connect to common ground plane.



## 1.0 Pin Description (Continued)

Table 1.

Pin #	Data Sheet Pin Name	Type	Connection / Comment
79	GTX_CLK/TCK	Input	<b>GMII Transmit Clock:</b> Connect to MAC chip through a single 50 $\Omega$ impedance trace. This input has a typical input capacitance of 6 pF
80	MDIO	Input / Output	<b>Management Data I/O:</b> This pin requires a 2k $\Omega$ parallel termination resistor (pull-up to VDD).
81	MDC	Input	<b>Management Data Clock:</b> Connect to MAC or controller using a 50 $\Omega$ impedance trace.
82	VSS	Ground	<b>Ground:</b> Connect to common ground plane.
83	IO_VDD	Power	<b>I/O VDD:</b> (Digital) Connect to 2.5V or 3.3V. The VDD_SEL pin must be tied accordingly.
84	RESERVED	Reserved	<b>Reserved:</b> Leave floating.
85	CLK_TO_MAC	Output	<b>Clock to MAC:</b> Connect to the reference clock input of a GMAC. Use pin MAC_CLK_EN_STRAP to disable this function.
86	CLK_IN	Input	<b>Clock Input:</b> Connect to external 25MHz reference clock source. If a crystal is used connect to first terminal of crystal.
87	CLK_OUT	Input	<b>Clock Output:</b> Connect to the second terminal of a crystal. Leave floating if an external clock source is used.
88	MAC_CLK_EN_STRAP	Strap	<b>Clock to MAC Enable:</b> Use a 2k $\Omega$ pull-down resistor to disable. Leave open to enable.
89	MDIX_EN_STRAP	Strap	<b>Automatic MDIX Enable:</b> Use a 2k $\Omega$ pull-down resistor to disable. Leave open to enable.
90	IO_VDD	Power	<b>I/O VDD:</b> (Digital) Connect to 2.5V or 3.3V. The VDD_SEL pin must be tied accordingly.
91	VSS	Ground	<b>Ground:</b> Connect to common ground plane.
92	CORE_VDD	Power	<b>Core VDD:</b> (Digital) Connect to 1.8V.
93	VSS	Ground	<b>Ground:</b> Connect to common ground plane.
94	MULTI_EN_STRAP	Strap	<b>Multiple Node Enable:</b> Use a 2k $\Omega$ pull-up resistor to enable. Leave open to disable.
95	PHYADDR4_STRAP	Strap	<b>PHY Address 4:</b> See section "5.9 LED/Strapping Option" on page 67 on how to connect this pin.
96	AFE_VDD	Power	<b>AFE VDD:</b> (Analog) Connect to 2.5V.
97	VSS	Ground	<b>Ground:</b> Connect to common ground plane.
98	PGM_VDD	Power	<b>PGM VDD:</b> Connect to 1.8V through a low pass filter. See section "5.4 Sensitive Supply Pins" on page 64 for details.
99	VSS	Ground	<b>Ground:</b> Connect to common ground plane.
100	1V8_AVDD3	Power	<b>Analog Supply:</b> Connect to 1.8V through a low pass filter. See section "5.4 Sensitive Supply Pins" on page 64 for details.
101	BG_VDD	Power	<b>BG VDD:</b> (Analog) Connect to 2.5V.
102	BG_REF	Input	<b>BG Reference:</b> See section "5.4 Sensitive Supply Pins" on page 64 on how to connect this pin.
103	RX_VDD	Power	<b>Receive VDD:</b> (Analog) Connect to 1.8V.
104	VSS	Ground	<b>Ground:</b> Connect to common ground plane.
105	RX_VDD	Power	<b>Receive VDD:</b> (Analog) Connect to 1.8V.
106	VSS	Ground	<b>Ground:</b> Connect to common ground plane.

## 1.0 Pin Description (Continued)

Table 1.

Pin #	Data Sheet Pin Name	Type	Connection / Comment
107	VSS	Ground	<b>Ground:</b> Connect to common ground plane.
108	MDIA_P	Input / Output	<b>MDI Channel A Positive:</b> Connect to TD+ of channel A of the magnetics.
109	MDIA_N	Input / Output	<b>MDI Channel A Negative:</b> Connect to TD- of channel A of the magnetics.
110	VSS	Ground	<b>Ground:</b> Connect to common ground plane.
111	RX_VDD	Power	<b>Receive VDD:</b> (Analog) Connect to 1.8 Volt.
112	VSS	Ground	<b>Ground:</b> Connect to common ground plane.
113	VSS	Ground	<b>Ground:</b> Connect to common ground plane.
114	MDIB_P	Input / Output	<b>MDI Channel B Positive:</b> Connect to TD+ of channel B of the magnetics.
115	MDIB_N	Input / Output	<b>MDI Channel B Negative:</b> Connect to TD- of channel B of the magnetics.
116	VSS	Ground	<b>Ground:</b> Connect to common ground plane.
117	RX_VDD	Power	<b>Receive VDD:</b> (Analog) Connect to 1.8V.
118	VSS	Ground	<b>Ground:</b> Connect to common ground plane.
119	VSS	Ground	<b>Ground:</b> Connect to common ground plane.
120	MDIC_P	Input / Output	<b>MDI Channel C Positive:</b> Connect to TD+ of channel C of the magnetics.
121	MDIC_N	Input / Output	<b>MDI Channel C Negative:</b> Connect to TD- of channel C of the magnetics.
122	VSS	Ground	<b>Ground:</b> Connect to common ground plane.
123	RX_VDD	Power	<b>Receive VDD:</b> (Analog) Connect to 1.8V.
124	VSS	Ground	<b>Ground:</b> Connect to common ground plane.
125	VSS	Ground	<b>Ground:</b> Connect to common ground plane.
126	MDID_P	Input / Output	<b>MDI Channel D Positive:</b> Connect to TD+ of channel D of the magnetics.
127	MDID_N	Input / Output	<b>MDI Channel D Negative:</b> Connect to TD- of channel D of the magnetics.
128	VSS	Ground	<b>Ground:</b> Connect to common ground plane.

## 2.0 Register Block

### 2.1 Register Definitions

Register maps and address definitions are given in the following table:

**Table 2. Register Block - DP83865 Register Map**

Offset		Access	Tag	Description
Hex	Decimal			
0x00	0	RW	BMCR	Basic Mode Control Register
0x01	1	RO	BMSR	Basic Mode Status Register
0x02	2	RO	PHYIDR1	PHY Identifier Register #1
0x03	3	RO	PHYIDR2	PHY Identifier Register #2
0x04	4	RW	ANAR	Auto-Negotiation Advertisement Register
0x05	5	RW	ANLPAR	Auto-Negotiation Link Partner Ability Register
0x06	6	RW	ANER	Auto-Negotiation Expansion Register
0x07	7	RW	ANNPTR	Auto-Negotiation Next Page TX
0x08	8	RW	ANNPRR	Auto-Negotiation Next Page RX
0x09	9	RW	1KTCR	1000BASE-T Control Register
0x0A	10	RO	1KSTSR	1000BASE-T Status Register
0x0B-0x0E	11-14	RO	Reserved	Reserved
0x0F	15	RO	1KSCR	1000BASE-T Extended Status Register
0x10	16	RO	STRAP_REG	Strap Options Register
0x11	17	RO	LINK_AN	Link and Auto-Negotiation Status Register
0x12	18	RW	AUX_CTRL	Auxiliary Control Register
0x13	19	RW	LED_CTRL	LED Control Register
0x14	20	RO	INT_STATUS	Interrupt Status Register
0x15	21	RW	INT_MASK	Interrupt Mask Register
0x16	22	RO	EXP_MEM_CTL	Expanded Memory Access Control
0x17	23	RW	INT_CLEAR	Interrupt Clear Register
0x18	24	RW	BIST_CNT	BIST Counter Register
0x19	25	RW	BIST_CFG1	BIST Configuration Register #1
0x1A	26	RW	BIST_CFG2	BIST Configuration Register #2
0x1B-0x1C	27-28	RO	Reserved	Reserved
0x1D	29	RW	EXP_MEM_DATA	Expanded Memory Data
0x1E	30	RW	EXP_MEM_ADDR	Expanded Memory Address
0x1F	31	RW	PHY_SUP	PHY Support Register

## 2.0 Register Block (Continued)

### 2.2 Register Map

Register Name	15	14	13	12	11	10	9	8	7	6	5	4	3	2	1	0
Register 0x00 Basic Mode Control Register (BMCR)	PHY Reset 0, SC	Loopback 0	Speed [0] Selection Strap[0]	Auto-Neg Enable Strap[1]	Power Down 0	Isolate 0	Restart Auto-Neg 0, SC	Duplex Mode Strap[1]	Collision Test 0	Speed[1] Selection Strap[1]	Reserved 0	Reserved 0	Reserved 0	Reserved 0	Reserved 0	Reserved 0
Register 0x01 Basic Mode Status Register (BMSR)	100BASE-T4 0	100BASE-X Full-Duplex 1	100BASE-X Half-Duplex 1	100BASE-T Full-Duplex 1	100BASE-T Half-Duplex 1	100BASE-T2 Full-Duplex 0	100BASE-T2 Half-Duplex 0	100BASE-T Ext'd Status 1	Reserved 0	Preamble Suppression 1	Auto-Neg Complete 0	Remote Fault 0, LH	Auto-Neg Ability 1	Link Status 0, LL	Jabber Detect 0, LH	Extended Capability 1
Register 0x02 PHY Identifier Register #1 (PHYIDR1)	OUI[3]	OUI[4]	OUI[5]	OUI[6]	OUI[7]	OUI[8]	OUI[9]	OUI[10]	OUI[11]	OUI[12]	OUI[13]	OUI[14]	OUI[15]	OUI[16]	OUI[17]	OUI[18]
Register 0x03 PHY Identifier Register #2 (PHYIDR2)	OUI[19]	OUI[20]	OUI[21]	OUI[22]	OUI[23]	OUI[24]	VMDR_MD[5]	VMDR_MD[4]	VMDR_MD[3]	VMDR_MD[2]	VMDR_MD[1]	VMDR_MD[0]	MDL_REV[3]	MDL_REV[2]	MDL_REV[1]	MDL_REV[0]
Register 0x04 Auto-Neg Advertisement Register (ANAR)	Next Page 0	Reserved 0	Remote Fault 0	Reserved 0	ASY_PAUSE 0	PAUSE 0	100BASE-T4 0	100BASE-TX Full-Duplex STRAP[1]	100BASE-TX Half-Duplex STRAP[1]	100BASE-T Full-Duplex STRAP[1]	100BASE-T Half-Duplex STRAP[1]	PSB[4]	PSB[3]	PSB[2]	PSB[1]	PSB[0]
Register 0x05 Auto-Neg Link Partner Ability Register (ANLPAR)	Next Page 0	ACK 0	Remote Fault 0	Reserved 0	Reserved 0	PAUSE 0	100BASE-T4 0	100BASE-TX Full-Duplex 0	100BASE-TX Half-Duplex 0	Reserved 0	Reserved 0	PDF 0, LH	LP_NP_Able 0	NP_Able 1	Page_RX 0, LH	LP_AN_Able 0
Register 0x06 Auto-Neg Expansion Register (ANER)	Reserved 0	Reserved 0	Reserved 0	Reserved 0	Reserved 0	Reserved 0	Reserved 0	Reserved 0	Reserved 0	Reserved 0	Reserved 0	Reserved 0	Reserved 0	Reserved 0	Reserved 0	Reserved 0
Register 0x07 Auto-Neg NP TX Register (ANNPTR)	Next Page 1	ACK 0	Message Page 1	ACK2 0	TOG_TX 0	NP_M[10]	NP_M[9]	NP_M[8]	NP_M[7]	NP_M[6]	NP_M[5]	NP_M[4]	NP_M[3]	NP_M[2]	NP_M[1]	NP_M[0]
Register 0x08 Auto-Neg NP RX Register (ANNPRR)	Next Page 0	ACK 0	Message Page 0	ACK2 0	TOG_RX 0	NP_M[10]	NP_M[9]	NP_M[8]	NP_M[7]	NP_M[6]	NP_M[5]	NP_M[4]	NP_M[3]	NP_M[2]	NP_M[1]	NP_M[0]
Register 0x09 100BASE-T Control Register (1KTCR)	Test Mode[2] 0	Test Mode[1] 0	Test Mode[0] 0	Master/Slave Config, Enable 0	Master/Slave Config, Value 0	Repeater DTE STRAP[0]	100BASE-T Full-Duplex STRAP[1]	100BASE-T Half-Duplex STRAP[1]	Reserved 0	Reserved 0	Reserved 0	Reserved 0	Reserved 0	Reserved 0	Reserved 0	Reserved 0
Register 0x0A (10'd) 100BASE-T Status Register (1KTSR)	Master/Slave Manual Config, Fault 0, LH, SC	Master/Slave, Config, Resol, 0	Local Receiver Status 0	Remote Re- ceiver Status 0	LP 100BASE-T Full-Duplex 0	LP 100BASE-T Half-Duplex 0	Reserved 0	Reserved 0	Idle Error Count[7] 0	Idle Error Count[6] 0	Idle Error Count[5] 0	Idle Error Count[4] 0	Idle Error Count[3] 0	Idle Error Count[2] 0	Idle Error Count[1] 0	Idle Error Count[0] 0
Register 0x0B (11'd) Reserved	Reserved 0	Reserved 0	Reserved 0	Reserved 0	Reserved 0	Reserved 0	Reserved 0	Reserved 0	Reserved 0	Reserved 0	Reserved 0	Reserved 0	Reserved 0	Reserved 0	Reserved 0	Reserved 0
Register 0x0C (12'd) Reserved	Reserved 0	Reserved 0	Reserved 0	Reserved 0	Reserved 0	Reserved 0	Reserved 0	Reserved 0	Reserved 0	Reserved 0	Reserved 0	Reserved 0	Reserved 0	Reserved 0	Reserved 0	Reserved 0
Register 0x0D (13'd) Reserved	Reserved 0	Reserved 0	Reserved 0	Reserved 0	Reserved 0	Reserved 0	Reserved 0	Reserved 0	Reserved 0	Reserved 0	Reserved 0	Reserved 0	Reserved 0	Reserved 0	Reserved 0	Reserved 0
Register 0x0E (14'd) Reserved	Reserved 0	Reserved 0	Reserved 0	Reserved 0	Reserved 0	Reserved 0	Reserved 0	Reserved 0	Reserved 0	Reserved 0	Reserved 0	Reserved 0	Reserved 0	Reserved 0	Reserved 0	Reserved 0
Register 0x0F (15'd) 100BASE-T Extended Status Register (1KSCR)	100BASE-X Full-Duplex 0	100BASE-X Half-Duplex 0	100BASE-T Full-Duplex 1	100BASE-T Half-Duplex 1	Reserved 0	Reserved 0	Reserved 0	Reserved 0	Reserved 0	Reserved 0	Reserved 0	Reserved 0	Reserved 0	Reserved 0	Reserved 0	Reserved 0

Key:

Bit Name Read/Writeable Default Value	Bit Name Read Only Value	Reserved
---	--------------------------------	----------

## 2.0 Register Block (Continued)

Register Name	15	14	13	12	11	10	9	8	7	6	5	4	3	2	1	0
Register 0x10 (16d) Strap Option Register (STRAP_REG)	AN Enable STRAP[1]	Full Duplex Enable STRAP[1]	Speed[1] STRAP[0]	Speed[0] STRAP[0]	Reserved (REF_SEL) STRAP[0]	Reserved (REF_SEL) STRAP[0]	Reserved (REF_SEL) STRAP[0]	Reserved (REF_SEL) STRAP[0]	MAC Clock Enable STRAP[1]	Auto MDIX Enable STRAP[1]	Multi Enable STRAP[0]	PHYADDR[4] STRAP[0]	PHYADDR[3] STRAP[0]	PHYADDR[2] STRAP[0]	PHYADDR[1] STRAP[0]	PHYADDR[0] STRAP[1]
Register 0x11 (17d) Link and Auto-Negotiation Status Register (LINK_AN)	TP_POL[3] 0	0	TP_POL[1] 0	TP_POL[0] 0	Reserved (Power Down Status) 0	MDIX Status 0	FIFO Error 0	Reserved (Power-On Init In Progress) 0	Reserved (Shallow Loop-back Status) 0	(Deep) Loop-back Status 0	NC Mode Status 0	Speed Status[1] 0	Speed Status[0] 0	Link Status 0	Duplex Status 0	Master/Slave Config. Status 0
Register 0x12 (18d) Auxiliary Control Register (AUX_CTRL)	Auto MDIX Enable STRAP[1]	Manual MDIX Mode STRAP[0]	RGML_EN[1] STRAP[0]	RGML_EN[0] STRAP[0]	Reserved (RGML Inband Sig. Enable) 0	Reserved (RGML Inband Sig. Enable) 0	NC Mode Enable STRAP[0]	RGML Inband Status Enable 0	TX_TCLK Enable 0	TX_TRIG /SYNC Enable 0	Shallow Loop-back Enable 0	X_Mac Enable 0	Reserved 0	Reserved 0	Reserved 0	Jabber Disable 0
Register 0x13 (19d) LED Control Register (LED_CTRL)	Act. LED[1] 0	Act. LED[0] 0	10BASE-T Link LED[1] 0	10BASE-T Link LED[0] 0	100BASE-TX Link LED[1] 0	100BASE-TX Link LED[0] 0	100BASE-T Link LED[1] 0	100BASE-T Link LED[0] 0	Duplex LED[1] 0	Duplex LED[0] 0	10M LED. RLED enable 0	Module LED on CRC Error 0	Module LED on Idle Error 0	AN Fallback on Gigabit Link 0	AN Fallback on CRC Error 0	AN Fallback on Idle Error 0
Interrupt Status Register (INT_STATUS)	Speed Change Int. 0	Link Change Int. 0	Duplex Change Int. 0	MDIX Change Int. 0	Polarity Change Int. 0	PDF Detection Fault Int. 0	Master/Slave Fail Int. 0	No HCD Int. 0	No Link Int. 0	Jabber Change Int. 0	Next Page Received Int. 0	Auto-Neg. Complete Int. 0	Remote Fault Change Int. 0	Reserved 0	Reserved 0	Reserved 0
Register 0x15 (21d) Interrupt Mask Register (INT_MASK)	Mask Int. 0	Mask Int. 0	Mask Int. 0	Mask Int. 0	Mask Int. 0	Mask Int. 0	Mask Int. 0	Mask Int. 0	Mask Int. 0	Mask Int. 0	Mask Int. 0	Mask Int. 0	Mask Int. 0	Mask Int. 0	Mask Int. 0	Reserved 0
Register 0x16 (22d) Exp. Memory Access Control (EXP_MEM_CTL)	Global Reset 0, SC	Reserved 0	Reserved 0	Reserved 0	Reserved 0	Reserved 0	Reserved (Broadcast Enable) 0	Reserved 0	Broadcast En. 0	Reserved 0	Reserved 0	Reserved 0	Reserved 0	Reserved 0	XMode[1] 0	XMode[0] 0
Register 0x17 (23d) Interrupt Clear Register (INT_CLEAR)	Clear Int. 0, SC	Clear Int. 0, SC	Clear Int. 0, SC	Clear Int. 0, SC	Clear Int. 0, SC	Clear Int. 0, SC	Clear Int. 0, SC	Clear Int. 0, SC	Clear Int. 0, SC	Clear Int. 0, SC	Clear Int. 0, SC	Clear Int. 0, SC	Clear Int. 0, SC	Clear Int. 0, SC	Reserved 0	Reserved 0
Register 0x18 (24d) BIST Counter Register (BIST_CNT)	Counter Bit[15] 0	Counter Bit[14] 0	Counter Bit[13] 0	Counter Bit[12] 0	Counter Bit[11] 0	Counter Bit[10] 0	Counter Bit[9] 0	Counter Bit[8] 0	Counter Bit[7] 0	Counter Bit[6] 0	Counter Bit[5] 0	Counter Bit[4] 0	Counter Bit[3] 0	Counter Bit[2] 0	Counter Bit[1] 0	Counter Bit[0] 0
Register 0x19 (25d) BIST Configuration Register #1 (BIST_CFG1)	BIST Counter Type 0	BIST Counter Clear 0	Transmit BIST Packet Length 0	Transmit BIST IPG Count[1] 0	Transmit BIST Enable 0	Transmit BIST Packet Type 0	Reserved 0	Reserved 0	Reserved 0	Transmit BIST Packet[6] 0	Transmit BIST Packet[5] 0	Transmit BIST Packet[4] 0	Transmit BIST Packet[3] 0	Transmit BIST Packet[2] 0	Transmit BIST Packet[1] 0	Transmit BIST Packet[0] 0
Register 0x1A (26d) BIST Configuration Register #2 (BIST_CFG2)	Receive BIST Enable 0	BIST Counter Select 0	Transmit BIST Packet Count[2] 0	Transmit BIST Packet Count[1] 0	Transmit BIST Packet Count[0] 0	Reserved 0	Reserved 0	Reserved 0	Reserved 0	Reserved 0	Reserved 0	Reserved 0	Reserved 0	Reserved 0	Reserved 0	10M LED ACT/LINK-LINK 0
Register 0x1B (27d) Reserved	Reserved 0	Reserved 0	Reserved 0	Reserved 0	Reserved 0	Reserved 0	Reserved 0	Reserved 0	Reserved 0	Reserved 0	Reserved 0	Reserved 0	Reserved 0	Reserved 0	Reserved 0	Reserved 0
Register 0x1C (28d) Reserved	Reserved 0	Reserved 0	Reserved 0	Reserved 0	Reserved 0	Reserved 0	Reserved 0	Reserved 0	Reserved 0	Reserved 0	Reserved 0	Reserved 0	Reserved 0	Reserved 0	Reserved 0	Reserved 0
Register 0x1D (29d) Exp. Memory Data (EXP_MEM_DATA)	Exp. Mem Data 15 0	Exp. Mem Data 14 0	Exp. Mem Data 13 0	Exp. Mem Data 12 0	Exp. Mem Data 11 0	Exp. Mem Data 10 0	Exp. Mem Data 9 0	Exp. Mem Data 8 0	Exp. Mem Data 7 0	Exp. Mem Data 6 0	Exp. Mem Data 5 0	Exp. Mem Data 4 0	Exp. Mem Data 3 0	Exp. Mem Data 2 0	Exp. Mem Data 1 0	Exp. Mem Data 0 0
Register 0x1E (30d) Exp. Memory Address Pointer (EXP_MEM_ADD)	Exp. Mem Addr 15 0	Exp. Mem Addr 14 0	Exp. Mem Addr 13 0	Exp. Mem Addr 12 0	Exp. Mem Addr 11 0	Exp. Mem Addr 10 0	Exp. Mem Addr 9 0	Exp. Mem Addr 8 0	Exp. Mem Addr 7 0	Exp. Mem Addr 6 0	Exp. Mem Addr 5 0	Exp. Mem Addr 4 0	Exp. Mem Addr 3 0	Exp. Mem Addr 2 0	Exp. Mem Addr 1 0	Exp. Mem Addr 0 0
Register 0x1F (31d) PHY Support Register (PHY_SUP)	Reserved 0	Reserved 0	Reserved 0	Reserved 0	Reserved BricSt_AD[3] 0	Reserved BricSt_AD[2] 0	Reserved BricSt_AD[1] 0	Reserved BricSt_AD[0] 0	Reserved 0	Reserved 0	Reserved 0	PHY ADDRESS[4] 0	PHY ADDRESS[3] 0	PHY ADDRESS[2] 0	PHY ADDRESS[1] 0	PHY ADDRESS[0] 1

Reserved

Bit Name  
Read Only  
Value

Bit Name  
Read/Writeable  
Default Value

Key:

## 2.0 Register Block (Continued)

### 2.3 Register Description

In the register description under the 'Default' heading, the following definitions hold true:

- RW = Read Write access
- RO = Read Only access
- LH = Latched High until read, based upon the occurrence of the corresponding event
- LL = Latched Low until read, based upon the occurrence of the corresponding event
- SC = Register sets on event occurrence (or is manually set) and Self-Clears when event ends
- P = Register bit is Permanently set to a default value
- STRAP[x] = Default value read from Strapped value at device pin at Reset, where x may take the values:
  - [0] internal pull-down
  - [1] internal pull-up

**Table 3. Basic Mode Control Register (BMCR) address 0x00**

Bit	Bit Name	Default	Description															
15	Reset	0, RW, SC	<p><b>Reset:</b></p> <p>1 = Initiate software Reset / Reset in Process. 0 = Normal operation.</p> <p>This bit sets the status and control registers of the PHY to their default states. This bit, which is self-clearing, returns a value of one until the reset process is complete (approximately 1.2 ms for reset duration). Reset is finished once the Auto-Negotiation process has begun or the device has entered it's forced mode.</p>															
14	Loopback	0, RW	<p><b>Loopback:</b></p> <p>1 = Loopback enabled. 0 = Normal operation.</p> <p>The loopback function enables MII/GMII transmit data to be routed to the MII/GMII receive data path. The data loops around at the DAC/ADC Subsystem (see block diagram page 2), bypassing the Drivers/Receivers block. This exercises most of the PHY's internal logic.</p>															
13	Speed[0]	STRAP[0], RW	<p><b>Speed Select:</b></p> <p>When Auto-Negotiation is disabled, bits 6 and 13 select device speed selection per table below:</p> <table style="margin-left: auto; margin-right: auto;"> <thead> <tr> <th><u>Speed[1]</u></th> <th><u>Speed[0]</u></th> <th><u>Speed Enabled</u></th> </tr> </thead> <tbody> <tr> <td>1</td> <td>1</td> <td>= Reserved</td> </tr> <tr> <td>1</td> <td>0</td> <td>= 1000 Mbps</td> </tr> <tr> <td>0</td> <td>1</td> <td>= 100 Mbps</td> </tr> <tr> <td>0</td> <td>0</td> <td>= 10 Mbps</td> </tr> </tbody> </table> <p>(The default value of this bit is = to the strap value of pin 7 during reset/power-on IF Auto-Negotiation is disabled.)</p>	<u>Speed[1]</u>	<u>Speed[0]</u>	<u>Speed Enabled</u>	1	1	= Reserved	1	0	= 1000 Mbps	0	1	= 100 Mbps	0	0	= 10 Mbps
<u>Speed[1]</u>	<u>Speed[0]</u>	<u>Speed Enabled</u>																
1	1	= Reserved																
1	0	= 1000 Mbps																
0	1	= 100 Mbps																
0	0	= 10 Mbps																
12	AN_EN	STRAP[1], RW	<p><b>Auto-Negotiation Enable:</b></p> <p>1 = Auto-Negotiation Enabled - bits 6, 8 and 13 of this register are ignored when this bit is set. 0 = Auto-Negotiation Disabled - bits 6, 8 and 13 determine the link speed and mode.</p> <p>(The default value of this bit is = to the strap value of pin 10 during reset/power-on.)</p>															

## 2.0 Register Block (Continued)

**Table 3. Basic Mode Control Register (BMCR) address 0x00**

Bit	Bit Name	Default	Description
11	Power_Down	0, RW	<p><b>Power Down:</b></p> <p>1 = Power down (only Management Interface and logic active.)            0 = Normal operation.</p> <p>Note: This mode is internally the same as isolate mode (bit 10).</p>
10	Isolate	0, RW	<p><b>Isolate:</b></p> <p>1 = Isolates the Port from the MII/GMII with the exception of the serial management. When this bit is asserted, the DP83865 does not respond to TXD[7:0], TX_EN, and TX_ER inputs, and it presents a high impedance on TX_CLK, RX_CLK, RX_DV, RX_ER, RXD[7:0], COL and CRS outputs.            0 = Normal operation.</p>
9	Restart_AN	0, RW, SC	<p><b>Restart Auto-Negotiation:</b></p> <p>1 = Restart Auto-Negotiation. Re-initiates the Auto-Negotiation process. If Auto-Negotiation is disabled (bit 12 = 0), this bit is ignored. This bit is self-clearing and will return a value of 1 until Auto-Negotiation is initiated, whereupon it will self-clear. Operation of the Auto-Negotiation process is not affected by the management entity clearing this bit.            0 = Normal operation.</p>
8	Duplex	STRAP[1], RW	<p><b>Duplex Mode:</b></p> <p>1 = Full Duplex operation. Duplex selection is allowed <u>only</u> when Auto-Negotiation is disabled (AN_EN = 0).            0 = Half Duplex operation.</p> <p>(The default value of this bit is = to the strap value of pin 9 during reset/power-on IF Auto-Negotiation is disabled.)</p>
7	Collision Test	0, RW	<p><b>Collision Test:</b></p> <p>1 = Collision test enabled.            0 = Normal operation.</p> <p>When set, this bit will cause the COL signal to be asserted in response to the assertion of TX_EN within TBD-bit times. The COL signal will be de-asserted within 4-bit times in response to the de-assertion of TX_EN.</p>
6	Speed[1]	STRAP[0], RW	<p><b>Speed Select:</b> See description for bit 13.            (The default value of this bit is = to the strap value of pin 8 during reset/power-on IF Auto-Negotiation is disabled.)</p>
5:0	Reserved	0, RO	<p><b>Reserved by IEEE:</b> Write ignored, read as 0.</p>

**Table 4. Basic Mode Status Register (BMSR) address 0x01**

15	100BASE-T4	0, P	<p><b>100BASE-T4 Capable:</b></p> <p>0 = Device not able to perform 100BASE-T4 mode.            DP83865 does not support 100BASE-T4 mode and bit should always be read back as "0".</p>
14	100BASE-X Full Duplex	1, P	<p><b>100BASE-X Full Duplex Capable:</b></p> <p>1 = Device able to perform 100BASE-X in Full Duplex mode.</p>
13	100BASE-X Half Duplex	1, P	<p><b>100BASE-X Half Duplex Capable:</b></p> <p>1 = Device able to perform 100BASE-X in Half Duplex mode.</p>

## 2.0 Register Block (Continued)

**Table 4. Basic Mode Status Register (BMSR) address 0x01**

12	10BASE-T Full Duplex	1, P	<b>10BASE-T Full Duplex Capable:</b> 1 = Device able to perform 10BASE-T in Full Duplex mode.
11	10BASE-T Half Duplex	1, P	<b>10BASE-T Half Duplex Capable:</b> 1 = Device able to perform 10BASE-T in Half Duplex mode.
10	100BASE-T2 Full Duplex	0, P	<b>100BASE-T2 Full Duplex Capable:</b> 0 = Device unable to perform 100BASE-T2 Full Duplex mode. DP83865 does not support 100BASE-T2 mode and bit should always be read back as "0".
9	100BASE-T2 Half Duplex	0, P	<b>100BASE-T2 Half Duplex Capable:</b> 0 = Device unable to perform 100BASE-T2 Half Duplex mode. DP83865 does not support 100BASE-T2 mode and bit should always be read back as "0".
8	1000BASE-T Extended Status	1, P	<b>1000BASE-T Extended Status Register:</b> 1 = Device supports Extended Status Register 0x0F.
7	Reserved	0, RO	<b>Reserved by IEEE:</b> Write ignored, read as 0.
6	Preamble Suppression	1, P	<b>Preamble suppression Capable:</b> 1 = Device able to perform management transaction with preamble suppressed, 32-bits of preamble needed only once after reset, invalid opcode or invalid turnaround.
5	Auto-Negotiation Complete	0, RO	<b>Auto-Negotiation Complete:</b> 1 = Auto-Negotiation process complete, and contents of registers 5, 6, 7, & 8 are valid. 0 = Auto-Negotiation process not complete.
4	Remote Fault	0, RO, LH	<b>Remote Fault:</b> 1 = Remote Fault condition detected (cleared on read or by reset). Fault criteria: Far End Fault Indication or notification from Link Partner of Remote Fault. 0 = No remote fault condition detected.
3	Auto-Negotiation Ability	1, P	<b>Auto Configuration Ability:</b> 1 = Device is able to perform Auto-Negotiation.
2	Link Status	0, RO, LL	<b>Link Lost Since Last Read Status:</b> 1 = Link was good since last read of this register. (10/100/1000 Mbps operation). 0 = Link was lost since last read of this register.  The occurrence of a link failure condition will causes the Link Status bit to clear. Once cleared, this bit may only be set by establishing a good link condition and a read via the management interface.  This bit doesn't indicate the link status, but rather if the link was lost since last read. For actual link status, either this register should be read twice, or register 0x11 bit 2 should be read.
1	Jabber Detect	0, RO, LH	<b>Jabber Detect:</b> Set to 1 if 10BASE-T Jabber detected locally. 1 = Jabber condition detected. 0 = No Jabber.
0	Extended Capability	1, P	<b>Extended Capability:</b> 1 = Extended register capable.



## 2.0 Register Block (Continued)

**Table 5. PHY Identifier Register #1 (PHYIDR1) address 0x02**

Bit	Bit Name	Default	Description
15:0	OUI[3:18]	16'b<0010_0000_0000_0000>, P	<b>OUI Bits 3:18:</b> Bits 3 to 18 of the OUI (0x080017h) are stored in bits 15 to 0 of this register. The most significant two bits of the OUI are ignored (the IEEE standard refers to these as bits 1 and 2).

The PHY Identifier Registers #1 and #2 together form a unique identifier for the DP83865. The Identifier consists of a concatenation of the Organizationally Unique Identifier (OUI), the vendor's model number and the model revision number. A PHY may return a value of zero in each of the 32 bits of the PHY Identifier if desired. The PHY Identifier is intended to support network management. National's IEEE assigned OUI is 0x080017h.

**Table 6. PHY Identifier Register #2 (PHYIDR2) address 0x03**

Bit	Bit Name	Default	Description
15:10	OUI[19:24]	6'b<01_0111>, P	<b>OUI Bits 19:24:</b> Bits 19 to 24 of the OUI (0x080017h) are mapped to bits 15 to 10 of this register respectively.
9:4	VNDR_MDL[5:0]	6'b <00_0111>, P	<b>Vendor Model Number:</b> The six bits of vendor model number are mapped to bits 9 to 4 (most significant bit to bit 9).
3:0	MDL_REV[3:0]	4'b <1010>, P	<b>Model Revision Number:</b> Four bits of the vendor model revision number are mapped to bits 3 to 0 (most significant bit to bit 3). This field will be incremented for all major device changes.

**Table 7. Auto-Negotiation Advertisement Register (ANAR) address 0x04**

Bit	Bit Name	Default	Description
15	NP	0, RW	<b>Next Page Indication:</b> 1 = Next Page Transfer desired. 0 = Next Page Transfer not desired.
14	Reserved	0, RO	<b>Reserved by IEEE:</b> Writes ignored, Read as 0.
13	RF	0, RW	<b>Remote Fault:</b> 1 = Advertises that this device has detected a Remote Fault. 0 = No Remote Fault detected.
12	Reserved	0, RO	<b>Reserved for Future IEEE use:</b> Write as 0, Read as 0.
11	ASY_PAUSE	0, RW	<b>Asymmetrical PAUSE:</b> 1 = MAC/Controller supports Asymmetrical Pause direction. 0 = MAC/Controller does not support Asymmetrical Pause direction.
10	PAUSE	0, RW	<b>PAUSE:</b> 1 = MAC/Controller supports Pause frames. 0 = MAC/Controller does not support Pause frames.
9	100BASE-T4	0, RO	<b>100BASE-T4 Support:</b> 1 = 100BASE-T4 supported. 0 = No support for 100BASE-T4. DP83865 does not support 100BASE-T4 mode and this bit should always be read back as "0".

## 2.0 Register Block (Continued)

Table 7. Auto-Negotiation Advertisement Register (ANAR) address 0x04

Bit	Bit Name	Default	Description															
8	100BASE-TX Full Duplex	STRAP[1], RW	<p><b>100BASE-TX Full Duplex Support:</b>            1 = 100BASE-TX Full Duplex is supported by the local device.            0 = 100BASE-TX Full Duplex not supported.</p> <p>The default value of this bit is determined by the combination of the Duplex Enable and Speed[1:0] strap pins during reset/power-on IF Auto-Negotiation is enabled.</p> <p>The advertised speed is determined by the Speed[1:0]:</p> <table border="1"> <thead> <tr> <th>Speed[1]</th> <th>Speed[0]</th> <th>Speeds Enabled</th> </tr> </thead> <tbody> <tr> <td>0</td> <td>0</td> <td>= 1000B-T, 100B-TX, 10B-T</td> </tr> <tr> <td>0</td> <td>1</td> <td>= 1000B-T, 100B-TX</td> </tr> <tr> <td>1</td> <td>0</td> <td>= 1000B-T</td> </tr> <tr> <td>1</td> <td>1</td> <td>= 1000B-T, 10B-T</td> </tr> </tbody> </table> <p>The advertised duplex mode is determined by Duplex Mode:            0 = Half Duplex            1 = Full Duplex</p>	Speed[1]	Speed[0]	Speeds Enabled	0	0	= 1000B-T, 100B-TX, 10B-T	0	1	= 1000B-T, 100B-TX	1	0	= 1000B-T	1	1	= 1000B-T, 10B-T
Speed[1]	Speed[0]	Speeds Enabled																
0	0	= 1000B-T, 100B-TX, 10B-T																
0	1	= 1000B-T, 100B-TX																
1	0	= 1000B-T																
1	1	= 1000B-T, 10B-T																
7	100BASE-TX (Half Duplex)	STRAP[1], RW	<p><b>100BASE-TX (Half Duplex) Support:</b>            1 = 100BASE-TX (Half Duplex) is supported by the local device.            0 = 100BASE-TX (Half Duplex) not supported.</p> <p>(The default value of this bit is determined by the combination of the Duplex Enable and Speed[1:0] strap pins during reset/power-on IF Auto-Negotiation is enabled. See bit 8 for details.)</p>															
6	10BASE-T Full Duplex	STRAP[1], RW	<p><b>10BASE-T Full Duplex Support:</b>            1 = 10BASE-T Full Duplex is supported.            0 = 10BASE-T Full Duplex is not supported.</p> <p>(The default value of this bit is determined by the combination of the Duplex Enable and Speed[1:0] strap pins during reset/power-on IF Auto-Negotiation is enabled. See bit 8 for details.)</p>															
5	10BASE-T (Half Duplex)	STRAP[1], RW	<p><b>10BASE-T (Half Duplex) Support:</b>            1 = 10BASE-T (Half Duplex) is supported by the local device.            0 = 10BASE-T (Half Duplex) is not supported.</p> <p>(The default value of this bit is determined by the combination of the Duplex Enable and Speed[1:0] strap pins during reset/power-on IF Auto-Negotiation is enabled. See bit 8 for details.)</p>															
4:0	PSB[4:0]	5'b<0_0001>, P	<p><b>Protocol Selection Bits:</b>            These bits contain the binary encoded protocol selector supported by this port. &lt;00001&gt; indicates that this device supports IEEE 802.3.</p>															

This register contains the advertised abilities of this device as they will be transmitted to its link partner during Auto-Negotiation.

## 2.0 Register Block (Continued)

**Table 8. Auto-Negotiation Link Partner Ability Register (ANLPAR) address 0x05**

Bit	Bit Name	Default	Description
15	NP	0, RO	<b>Next Page Indication:</b> 0 = Link Partner does not desire Next Page Transfer. 1 = Link Partner desires Next Page Transfer.
14	ACK	0, RO	<b>Acknowledge:</b> 1 = Link Partner acknowledges reception of the ability data word. 0 = Not acknowledged.  The Device's Auto-Negotiation state machine will automatically control this bit based on the incoming FLP bursts. Software should not attempt to write to this bit.
13	RF	0, RO	<b>Remote Fault:</b> 1 = Remote Fault indicated by Link Partner. 0 = No Remote Fault indicated by Link Partner.
12	Reserved	0, RO	<b>Reserved for Future IEEE use:</b> Write as 0, read as 0.
11	ASY_PAUSE	0, RO	<b>Asymmetrical PAUSE:</b> 1 = Link Partner supports Asymmetrical Pause direction. 0 = Link Partner does not support Asymmetrical Pause direction.
10	PAUSE	0, RO	<b>PAUSE:</b> 1 = Link Partner supports Pause frames. 0 = Link Partner does not support Pause frames.
9	100BASE-T4	0, RO	<b>100BASE-T4 Support:</b> 1 = 100BASE-T4 is supported by the Link Partner. 0 = 100BASE-T4 not supported by the Link Partner.
8	100BASE-TX Full Duplex	0, RO	<b>100BASE-TX Full Duplex Support:</b> 1 = 100BASE-TX Full Duplex is supported by the Link Partner. 0 = 100BASE-TX Full Duplex not supported by the Link Partner.
7	100BASE-TX (Half Duplex)	0, RO	<b>100BASE-TX (Half Duplex) Support:</b> 1 = 100BASE-TX (Half Duplex) is supported by the Link Partner. 0 = 100BASE-TX (Half Duplex) not supported by the Link Partner.
6	10BASE-T Full Duplex	0, RO	<b>10BASE-T Full Duplex Support:</b> 1 = 10BASE-T Full Duplex is supported by the Link Partner. 0 = 10BASE-T Full Duplex not supported by the Link Partner.
5	10BASE-T (Half Duplex)	0, RO	<b>10BASE-T (Half Duplex) Support:</b> 1 = 10BASE-T (Half Duplex) is supported by the Link Partner. 0 = 10BASE-T (Half Duplex) not supported by the Link Partner.
4:0	PSB[4:0]	5'b<0_0000>, RO	<b>Protocol Selection Bits:</b> Link Partners's binary encoded protocol selector.

This register contains the advertised abilities of the Link Partner as received during Auto-Negotiation

## 2.0 Register Block (Continued)

Table 9. Auto-Negotiate Expansion Register (ANER) address 0x06

Bit	Bit Name	Default	Description
15:5	Reserved	0, RO	<b>Reserved by IEEE:</b> Writes ignored, Read as 0.
4	PDF	0, RO, LH	<b>Parallel Detection Fault:</b> 1 = A fault has been detected via the Parallel Detection function. 0 = A fault has not been detected via the Parallel Detection function.
3	LP_NP Able	0, RO	<b>Link Partner Next Page Able:</b> 1 = Link Partner does support Next Page. 0 = Link Partner supports Next Page negotiation.
2	NP Able	1, RO	<b>Next Page Able:</b> 1 = Indicates local device is able to send additional "Next Pages".
1	PAGE_RX	0, RO, LH	<b>Link Code Word Page Received:</b> 1 = Link Code Word has been received, cleared on read of this register. 0 = Link Code Word has not been received.
0	LP_AN Able	0, RO	<b>Link Partner Auto-Negotiation Able:</b> 1 = Indicates that the Link Partner supports Auto-Negotiation. 0 = Indicates that the Link Partner does not support Auto-Negotiation.

This register contains additional Local Device and Link Partner status information.

Table 10. Auto-Negotiation Next Page Transmit Register (ANNPTR) address 0x07

Bit	Bit Name	Default	Description
15	NP	1, RW	<b>Next Page Indication:</b> 1 = Another Next Page desired. 0 = No other Next Page Transfer desired.
14	ACK	0, RO	<b>Acknowledge:</b> 1 = Acknowledge of 3 consecutive FLPs. 0 = No Link Code Word received.
13	MP	1, RW	<b>Message Page:</b> 1 = Message Page. 0 = Unformatted Page.
12	ACK2	0, RW	<b>Acknowledge2:</b> 1 = Will comply with message. 0 = Cannot comply with message. Acknowledge2 is used by the next page function to indicate that Local Device has the ability to comply with the message received.

## 2.0 Register Block (Continued)

**Table 10. Auto-Negotiation Next Page Transmit Register (ANNPTR) address 0x07**

Bit	Bit Name	Default	Description
11	TOG_TX	0, RO	<p><b>Toggle:</b></p> <p>1 = Value of toggle bit in previously transmitted Link Code Word was logic 0.</p> <p>0 = Value of toggle bit in previously transmitted Link Code Word was logic 1.</p> <p>Toggle is used by the Arbitration function within Auto-Negotiation to ensure synchronization with the Link Partner during Next Page exchange. This bit shall always take the opposite value of the Toggle bit in the previously exchanged Link Code Word.</p>
10:0	CODE[10:0]	11'b<000_0000_1000>, RW	<p>This field represents the code field of the next page transmission. If the MP bit is set (bit 13 of this register), then the code shall be interpreted as a "Message Page", as defined in annex 28C of IEEE 802.3u. Otherwise, the code shall be interpreted as an "Unformatted Page", and the interpretation is application specific.</p> <p>The default value of the CODE represents a Null Page as defined in Annex 28C of IEEE 802.3u.</p>

This register contains the next page information sent by this device to its Link Partner during Auto-Negotiation.

**Table 11. Auto-Negotiation Next Page Receive Register (ANNPRR) address 0x08**

Bit	Bit Name	Default	Description
15	NP	0, RO	<p><b>Next Page Indication:</b></p> <p>1 = Another Next Page desired.</p> <p>0 = No other Next Page Transfer desired.</p>
14	ACK	0, RO	<p><b>Acknowledge:</b></p> <p>1 = Link Partner acknowledges reception of the next page.</p> <p>0 = Not acknowledged.</p>
13	MP	0, RO	<p><b>Message Page:</b></p> <p>1 = Message Page.</p> <p>0 = Unformatted Page.</p>
12	ACK2	0, RO	<p><b>Acknowledge2:</b></p> <p>1 = Link Partner will comply with message.</p> <p>0 = Cannot comply with message.</p> <p>Acknowledge2 is used by the next page function to indicate that the Link Partner has the ability to comply with the message received.</p>

## 2.0 Register Block (Continued)

**Table 11. Auto-Negotiation Next Page Receive Register (ANNPRR) address 0x08**

Bit	Bit Name	Default	Description
11	TOG_RX	0, RO	<p><b>Toggle:</b></p> <p>1 = Value of toggle bit in previously transmitted Link Code Word was logic 0.</p> <p>0 = Value of toggle bit in previously transmitted Link Code Word was logic 1.</p> <p>Toggle is used by the Arbitration function within Auto-Negotiation to ensure synchronization with the Link Partner during Next Page exchange. This bit shall always take the opposite value of the Toggle bit in the previously exchanged Link Code Word.</p>
10:0	CODE[10:0]	11'b<000_000_0000>, RO	<p>This field represents the code field of the next page transmission. If the MP bit is set (bit 13 of this register), then the code shall be interpreted as a "Message Page", as defined in annex 28C of IEEE 802.3u. Otherwise, the code shall be interpreted as an "Unformatted Page", and the interpretation is application specific.</p> <p>The default value of the CODE represents a Reserved for future use as defined in Annex 28C of IEEE 802.3u.</p>

This register contains the next page information sent by its Link Partner during Auto-Negotiation.

**Table 12. 1000BASE-T Control Register (1KTCR) address 0x09**

Bit	Bit Name	Default	Description																								
15:13	Test Mode	0, RW	<p><b>Test Mode Select:</b></p> <table border="1"> <thead> <tr> <th>bit 15</th> <th>bit 14</th> <th>bit 13</th> <th>Test Mode Selected</th> </tr> </thead> <tbody> <tr> <td>1</td> <td>0</td> <td>0</td> <td>= Test Mode 4</td> </tr> <tr> <td>0</td> <td>1</td> <td>1</td> <td>= Test mode 3</td> </tr> <tr> <td>0</td> <td>1</td> <td>0</td> <td>= Test Mode 2</td> </tr> <tr> <td>0</td> <td>0</td> <td>1</td> <td>= Test Mode 1</td> </tr> <tr> <td>0</td> <td>0</td> <td>0</td> <td>= Normal Operation</td> </tr> </tbody> </table> <p>See IEEE 802.3ab section 40.6.1.1.2 "Test modes" for more information. Output for TX_TCLK when in Test Mode is on pin 6.</p>	bit 15	bit 14	bit 13	Test Mode Selected	1	0	0	= Test Mode 4	0	1	1	= Test mode 3	0	1	0	= Test Mode 2	0	0	1	= Test Mode 1	0	0	0	= Normal Operation
bit 15	bit 14	bit 13	Test Mode Selected																								
1	0	0	= Test Mode 4																								
0	1	1	= Test mode 3																								
0	1	0	= Test Mode 2																								
0	0	1	= Test Mode 1																								
0	0	0	= Normal Operation																								
12	Master / Slave Manual Config. Enable	0, RW	<p><b>Enable Manual Master / Slave Configuration:</b></p> <p>1 = Enable Manual Master/Slave Configuration control.</p> <p>0 = Disable Manual Master/Slave Configuration control.</p> <p>Using the manual configuration feature may prevent the PHY from establishing link in 1000Base-T mode if a conflict with the link partner's setting exists.</p>																								
11	Master / Slave Config. Value	0, RW	<p><b>Manual Master / Slave Configuration Value:</b></p> <p>1 = Set PHY as MASTER when register 09h bit 12 = 1.</p> <p>0 = Set PHY as SLAVE when register 09h bit 12 = 1.</p> <p>Using the manual configuration feature may prevent the PHY from establishing link in 1000Base-T mode if a conflict with the link partner's setting exists.</p>																								
10	Repeater / DTE	STRAP[0], RW	<p><b>Advertise Device Type: Multi or single port</b></p> <p>1 = Repeater or Switch.</p> <p>0 = DTE.</p> <p>(The default value of this bit is = to the strap value of pin 94 during reset/power-on IF Auto-Negotiation is enabled.)</p>																								

## 2.0 Register Block (Continued)

**Table 12. 1000BASE-T Control Register (1KTCCR) address 0x09**

Bit	Bit Name	Default	Description
9	1000BASE-T Full Duplex	STRAP[1], RW	<b>Advertise 1000BASE-T Full Duplex Capable:</b> 1 = Advertise DTE as 1000BASE-T Full Duplex Capable. 0 = Advertise DTE as not 1000BASE-T Full Duplex Capable. (The default value of this bit is determined by the combination of the Duplex Enable and Speed[1:0] strap pins during reset/power-on IF Auto-Negotiation is enabled. See register 0x04 bit 8 for details.)
8	1000BASE-T Half Duplex	STRAP[1], RW	<b>Advertise 1000BASE-T Half Duplex Capable:</b> 1 = Advertise DTE as 1000BASE-T Half Duplex Capable. 0 = Advertise DTE as not 1000BASE-T Half Duplex Capable. (The default value of this bit is determined by the combination of the Duplex Enable and Speed[1:0] strap pins during reset/power-on IF Auto-Negotiation is enabled. See register 0x04 bit 8 for details.)
7:0	Reserved	0, RW	<b>Reserved by IEEE:</b> Writes ignored, Read as 0.

**Table 13. 1000BASE-T Status Register (1KSTSR) address 0x0A (10'd)**

Bit	Bit Name	Default	Description
15	Master / Slave Manual Config. Fault	0, RO, LH, SC	<b>MASTER / SLAVE manual configuration fault detected:</b> 1 = MASTER/SLAVE manual configuration fault detected. 0 = No MASTER/SLAVE manual configuration fault detected.
14	Master / Slave Config. Resolution	0, RO	<b>MASTER / SLAVE Configuration Results:</b> 1 = Configuration resolved to MASTER. 0 = Configuration resolved to SLAVE.
13	Local Receiver Status	0, RO	<b>Local Receiver Status:</b> 1 = OK. 0 = Not OK.
12	Remote Receiver Status	0, RO	<b>Remote Receiver Status:</b> 1 = OK. 0 = Not OK.
11	LP 1000BASE-T Full Duplex	0, RO	<b>Link Partner 1000BASE-T Full Duplex:</b> 1 = Link Partner capable of 1000BASE-T Full Duplex. 0 = Link Partner not capable of 1000BASE-T Full Duplex.
10	LP 1000BASE-T Half Duplex	0, RO	<b>Link Partner 1000BASE-T Half Duplex:</b> 1 = Link Partner capable of 1000BASE-T Half Duplex. 0 = Link Partner not capable of 1000BASE-T Half Duplex.
9:8	Reserved	0, RO	<b>Reserved by IEEE:</b> Write ignored, read as 0.
7:0	IDLE ErrorCount[7:0]	0, RO, SC	<b>IDLE Error Count</b>

This register provides status for 1000BASE-T link.

**Note:** Registers 0x0B - 0x0E are Reserved by IEEE.

## 2.0 Register Block (Continued)

**Table 14. 1000BASE-T Extended Status Register (1KSCR) address 0x0F (15'd)**

Bit	Bit Name	Default	Description
15	1000BASE-X Full Duplex	0, P	<b>1000BASE-X Full Duplex Support:</b> 1 = 1000BASE-X is supported by the local device. 0 = 1000BASE-X is not supported. DP83865 does not support 1000BASE-X and bit should always be read back as "0".
14	1000BASE-X Half Duplex	0, P	<b>1000BASE-X Half Duplex Support:</b> 1 = 1000BASE-X is supported by the local device. 0 = 1000BASE-X is not supported. DP83865 does not support 1000BASE-X and bit should always be read back as "0".
13	1000BASE-T Full Duplex	1, P	<b>1000BASE-T Full Duplex Support:</b> 1 = 1000BASE-T is supported by the local device. 0 = 1000BASE-T is not supported.
12	1000BASE-T Half Duplex	1, P	<b>1000BASE-T Half Duplex Support:</b> 1 = 1000BASE-T is supported by the local device. 0 = 1000BASE-T is not supported.
11:0	Reserved	0, RO	<b>Reserved by IEEE:</b> Write ignored, read as 0.

**Table 15. Strap Option Register (STRAP\_REG) address 0x10 (16'd)**

Bit	Bit Name	Default	Description
15	AN Enable	STRAP[1], RO	<b>Auto-Negotiation Enable:</b> Pin 10. Default value for bit 12 of register 0x00.
14	Duplex Mode	STRAP[1], RO	<b>Duplex Mode:</b> Pin 9. Default value for bit 8 of register 0x00.
13:12	Speed[1:0]	STRAP[00], RO	<b>Speed Select:</b> Pins 8 and 7. Default value for bits 6 and 13 of register 0x00.
11	Reserved	0, RO	Write as 0, ignore on read.
10	NC Mode Enable	STRAP[0], RO	<b>Non-Compliant Mode:</b> Pin 1. Default value for bit 9 of register 0x12.
9	Reserved	0, RO	Write as 0, ignore on read.
8	Reserved	0, RO	Write as 0, ignore on read.
7	MAC Clock Enable	STRAP[1], RO	<b>MAC Clock Output Enable:</b> Pin 88.
6	MDIX Enable	STRAP[1], RO	<b>Auto MDIX Enable:</b> Pin 89. Default value for bit 15 of register 0x12.
5	Multi Enable	STRAP[0], RO	<b>Multi Port Enable:</b> Pin 94. Default value for bit 10 of register 0x09.
4:0	PHYADDR[4:0]	STRAP[0_0001], RO	<b>PHY Address:</b> Pins 95, 18, 17, 14, 13. Default for bits 4:0 of register 0x1F.

This register summarizes all the strap options. These can only be changed through restrapping and resetting the PHY.



## 2.0 Register Block (Continued)

Table 16. Link and Auto-Negotiation Status Register (LINK\_AN) address 0x11 (17'd)

Bit	Bit Name	Default	Description															
15:12	TP Polarity[3:0]	0, RO	<b>Twisted Pair Polarity Status:</b> Indicates a polarity reversal on pairs A to D ([15:12]). The PHY automatically detects this condition and adjusts for it. 1 = polarity reversed 0 = normal operation															
11	Reserved (Power Down Status)	0, RO	Write as 0, ignore on read. This bit is set to indicate that the PHY is in power down mode.															
10	MDIX Status	0, RO	<b>MDIX Status:</b> Indicates whether the PHY's MDI is in straight or cross-over mode. 1 = Cross-over mode 0 = Straight mode															
9	FIFO Error	0, RO	<b>Transmit FIFO Error:</b> Indicates whether a FIFO overflow or under-run has occurred. This bit is cleared every time link is lost. 1 = FIFO error occurred 0 = normal operation															
8	Reserved	0, RO	Write as 0, ignore on read.															
7	Shallow Loopback Status	0, RO	<b>Shallow Loopback Status:</b> (As set by bit 5, register 0x12) 1 = The PHY operates in shallow loopback mode 0 = Normal operation															
6	Deep Loopback Status	0, RO	<b>Deep Loopback Status:</b> (As set by bit 14, register 0x00) 1 = The PHY operates in deep loopback mode 0 = Normal operation															
5	Non-Compliant Mode Status	0, RO	<b>Non-compliant Mode Status:</b> '1' detects only in non-compliant mode '0' detects in both IEEE compliant and non-compliant mode															
4:3	Speed[1:0] Status	STRAP[00], RO	<b>Speed Resolved:</b> These two bits indicate the speed of operation as determined by Auto-negotiation or as set by manual configuration. <table border="1" style="margin-left: auto; margin-right: auto;"> <thead> <tr> <th>Speed[1]</th> <th>Speed[0]</th> <th>Speed of operation</th> </tr> </thead> <tbody> <tr> <td>1</td> <td>0</td> <td>= 1000 Mbps</td> </tr> <tr> <td>0</td> <td>1</td> <td>= 100 Mbps</td> </tr> <tr> <td>0</td> <td>0</td> <td>= 10 Mbps</td> </tr> <tr> <td>1</td> <td>1</td> <td>= reserved</td> </tr> </tbody> </table>	Speed[1]	Speed[0]	Speed of operation	1	0	= 1000 Mbps	0	1	= 100 Mbps	0	0	= 10 Mbps	1	1	= reserved
Speed[1]	Speed[0]	Speed of operation																
1	0	= 1000 Mbps																
0	1	= 100 Mbps																
0	0	= 10 Mbps																
1	1	= reserved																
2	Link Status	0, RO	<b>Link status:</b> 1 = indicates that a good link is established 0 = indicates no link.															
1	Duplex Status	0, RO	<b>Duplex status:</b> 1 = indicates that the current mode of operation is full duplex 0 = indicates that the current mode of operation is half duplex															
0	Master / Slave Config. Status	0, RO	<b>Master / Slave Configuration Status:</b> 1 = PHY is currently in Master mode 0 = PHY is currently in Slave mode															

## 2.0 Register Block (Continued)

Table 17. Auxiliary Control Register (AUX\_CTRL) address 0x12 (18'd)

Bit	Bit Name	Default	Description
15	Auto-MDIX Enable	STRAP[1], RW	<p><b>Automatic MDIX:</b> Indicates (sets) whether the PHY's capability to automatically detect swapped cable pairs is used.</p> <p>1 = Automatic MDIX mode, bit 14 is ignored 0 = Manual MDIX mode</p> <p>Note: This bit is ignored and the setting of bit 14 applies if Auto-Negotiation is disabled (AN_EN = 0). Bit 10 of register 0x11 should always be checked for the actual status of MDI/MDIX operation.</p>
14	Manual MDIX Value	STRAP[0], RW	<p><b>Manual MDIX Value:</b> If Manual MDIX mode is selected (Auto-MDIX selection is disabled, bit 15 = 0) this bit sets the MDIX mode of operation. If the PHY is in Auto-MDIX mode this bit has no effect.</p> <p>1 = cross-over mode (channels A and B are swapped) 0 = straight mode</p> <p>Note: Bit 10 of register 0x11 should always be checked for the actual status of MDI/MDIX operation.</p>
13:12	RGMII_EN[1:0]	STRAP[0]	<p><b>RGMII ENABLE:</b> These two bits enables RGMII mode or MII/GMII mode.</p> <p><b>RGMII_EN[1:0]</b> 11 = RGMII - 3COM mode 10 = RGMII - HP mode 01 = GMII mode 00 = GMII mode</p>
11:10	Reserved	0, RO	Write as 0, ignore on read.
9	Non-Compliant Mode	STRAP[0], RW	<p><b>Non-Compliant Mode Enable:</b> This bit enables the PHY to work in non-IEEE compliant mode. This allows interoperability with certain non-IEEE compliant 1000BASE-T transceivers.</p> <p>1 = enables IEEE compliant operation and non-compliant operation 0 = enables IEEE compliant operation but inhibits non-compliant operation</p>
8	RGMII InBand Status Enable	0, RW	<p><b>RGMII InBand Status Enable:</b></p> <p>1 = RGMII InBand Status enabled. 0 = RGMII InBand Status disabled.</p> <p>When InBand Status is enabled, PHY places link status, speed, and duplex mode information on RXD[3:0] between the data frames. The InBand Status may ease the MAC layer design.</p> <p>Note that this bit has no impact if bit 13 = 0.</p>
7	TX_TCLK Enable	0, RW	<p><b>TX_TCLK Enable:</b> This bit enables the TX_TCLK (pin 6) output during the IEEE 1000BASE-T test modes.</p> <p>1 = TX_TCLK output enabled during IEEE test modes 0 = No TX_TCLK output (default)</p>
6	TX_Trigger_Syn Enable	0, RW	<p><b>TX_TRIGGER and TX_SYNC Enable:</b> This bit enables the TX_SYNC_CLK (pin 88) and TX_TRIGGER (pin 94) output during the IEEE 1000BASE-T modes. These signals are not required by IEEE to perform the tests, but will help to take measurements.</p> <p>0 = No signal output 1 = Signal are output during IEEE test modes</p> <p>Note: TX_SYNC_CLK and TX_TRIGGER are only available in test mode 1 and 4 TX_SYNC_CLK = TX_TCLK / 4 in test mode 1 TX_SYNC_CLK = TX_TCLK / 6 in test mode 4</p>

## 2.0 Register Block (Continued)

**Table 17. Auxiliary Control Register (AUX\_CTRL) address 0x12 (18'd)**

Bit	Bit Name	Default	Description
5	Shallow Deep Loopback Enable	0, RW	<b>Shallow Deep Loopback Enable:</b> (Loopback status bit 7, register 0x11) This bit places PHY in the MAC side loopback mode. Any packet entering into TX side appears on the RX pins immediately. This operation bypasses all internal logic and packet does not appear on the MDI interface. 1 = The PHY operates in shallow deep loopback mode 0 = Normal operation
4	X_Mac	0, RW	<b>Reverse GMII Data Bit Order:</b> Setting this bit will reverse the pins of the TXD and RXD on the GMII interface, respectively. 1 = TXD[7:0]=>TXD[0:7], RXD[7:0]=>RXD[0:7] 0 = Normal operation
3:1	Reserved	0, RO	Write as 0, ignore on read.
0	Jabber Disable	0, RW	<b>Jabber Disable:</b> (Only in 10BASE-T mode) If this bit is set the PHY ignores all jabber conditions. 1 = disable jabber function 0 = normal operation

**Table 18. LED Control Register (LED\_CTRL) address 0x13 (19'd)**

Bit	Bit Name	Default	Description
15:14	Activity LED	0, RW	<b>Activity LED:</b> This LED is active when the PHY is transmitting data, receiving data, or detecting idle error. The following modes are available for the ACT LED: 00 = Register controlled 0x13.3:0 01 = Forced off 10 = Blink mode (blink rate approx. 750 ms) 11 = Forced on Note: Only in normal mode (00) LEDs reflect the actual status of the PHY. All other modes force the driver to a permanent on, off or blinking state.
13:12	Link10 LED	0, RW	<b>10BASE-T Link LED:</b> This LED is active when the PHY is linked in 10BASE-T mode. The following modes are available for LEDs: 00 = Normal (default) 01 = Forced off 10 = Blink mode (blink rate approx. 750 ms) 11 = Forced on Note: Only in normal mode (00) LEDs reflect the actual status of the PHY. All other modes force the driver to a permanent on, off or blinking state.
11:10	Link100 LED	0, RW	<b>100BASE-TX Link LED:</b> This LED is active when the PHY is linked in 100BASE-TX mode. See Activity LED for other settings.
9:8	Link1000 LED	0, RW	<b>1000BASE-T Link LED:</b> This LED is active when the PHY is linked in 1000BASE-T mode. See Activity LED for other settings.
7:6	Duplex LED	0, RW	<b>Duplex LED:</b> This LED is active when the PHY has established a link in Full Duplex mode. See Activity LED for other settings.

## 2.0 Register Block (Continued)

**Table 18. LED Control Register (LED\_CTRL) address 0x13 (19'd)**

Bit	Bit Name	Default	Description
5	reduced LED enable	0, RW	<p><b>Reduced LED Mode Enable:</b> This bit enables the reduced LED (RLED) mode that is different from the normal five-LED mode. In the RLED Mode, 10M Link LED is changed to link LED or Link and activity combined LED.</p> <p>When reg 0x13.5 is enabled:            Reg 0x1A.0 = 1 - 10M Link LED displays 10/100/1000 Link            Reg 0x1A.0 = 0 - 10M LED displays 10/100/1000 Link and ACT</p> <p>Note: In Link mode, the LED is steady on. In Link/ACT mode, LED is steady on when link is achieved, and LED blinks when there is link and activity.</p>
4	led_on_crc	0, RW	
3	led_on_ie	0, RW	
2	an_fallback_an	0, RW	
1	an_fallback_crc	0, RW	
0	an_fallback_ie	0, RW	

**Table 19. Interrupt Status Register (INT\_STATUS) address 0x14 (20'd)**

Bit	Bit Name	Default	Description
15	spd_cng_int	0, RO	<b>Speed Change:</b> Asserted when the speed of a link changes.
14	lnk_cng_int	0, RO	<b>Link Change:</b> Asserted when a link is established or broken.
13	dplx_cng_int	0, RO	<b>Duplex Change:</b> Asserted when the duplex mode of a link changes.
12	mdix_cng_int	0, RO	<b>MDIX Change:</b> Asserted when the MDIX status changes, i.e. a pair swap occurred.
11	pol_cng_int	0, RO	<b>Polarity Change:</b> Asserted when the polarity of any channel changes.
10	pri_det_flt_int	0, RO	<b>Parallel Detection Fault:</b> Asserted when a parallel detectin fault has been detected.
9	mas_sla_err_int	0, RO	<b>Master / Slave Error:</b> Asserted when the Master / Slave configuration in 1000BASE-T mode could not be resolved.
8	no_hcd_int	0, RO	<b>No HCD:</b> Asserted when Auto-Negotiation could not determine a Highest Common Denominator.
7	no_lnk_int	0, RO	<b>No Link after Auto-Negotiation:</b> Asserted when Auto-Negotiation has been completed successfully and no link could be established.
6	jabber_cng_int	0, RO	<b>Jabber Change:</b> Asserted in 10BASE-T mode when a Jabber condition has occurred or has been cleared.
5	nxt_pg_rcvd_int	0, RO	<b>Next Page Received:</b> Asserted when a Next Page has been received.
4	an_cmpl_int	0, RO	<b>Auto-negotiation complete:</b> Asserted when Auto-Negotiation has been completed.
3	rem_flt_cng_int	0, RO	<b>Remote Fault Change:</b> Asserted when the remote fault status changes.
2:0	Reserved	0, RO	Write as 0, ignore on read.

## 2.0 Register Block (Continued)

**Table 20. Interrupt Mask Register (INT\_MASK) address 0x15 (21'd)**

Bit	Bit Name	Default	Description
15	spd_cng_int_msk	0, RW	Setting this bit activates the spd_cng_int interrupt. The interrupt is masked if the bit is cleared.
14	lnk_cng_int_msk	0, RW	Setting this bit activates the lnk_cng_int interrupt. The interrupt is masked if the bit is cleared.
13	dplx_cng_int_msk	0, RW	Setting this bit activates the dplx_cng_int interrupt. The interrupt is masked if the bit is cleared.
12	mdix_cng_int_msk	0, RW	Setting this bit activates the mdix_cng_int interrupt. The interrupt is masked if the bit is cleared.
11	pol_cng_int_msk	0, RW	Setting this bit activates the pol_cng_int interrupt. The interrupt is masked if the bit is cleared.
10	prl_detflt_int_msk	0, RW	Setting this bit activates the prl_detflt_int interrupt. The interrupt is masked if the bit is cleared.
9	mas_sla_err_int_msk	0, RW	Setting this bit activates the mas_sla_err_int interrupt. The interrupt is masked if the bit is cleared.
8	no_hcd_int_msk	0, RW	Setting this bit activates the no_hcd_int interrupt. The interrupt is masked if the bit is cleared.
7	no_lnk_int_msk	0, RW	Setting this bit activates the no_lnk_int interrupt. The interrupt is masked if the bit is cleared.
6	jabber_cng_int_msk	0, RW	Setting this bit activates the jabber_cng_int interrupt. The interrupt is masked if the bit is cleared.
5	nxt_pg_rcvd_int_msk	0, RW	Setting this bit activates the nxt_pg_rcvd_int interrupt. The interrupt is masked if the bit is cleared.
4	an_cmpl_int_msk	0, RW	Setting this bit activates the an_cmpl_int interrupt. The interrupt is masked if the bit is cleared.
3	remflt_cng_int_msk	0, RW	Setting this bit activates the remflt_cng_int interrupt. The interrupt is masked if the bit is cleared.
2:0	Reserved	0, RO	Write as 0, ignore on read.

**Table 21. Expanded Memory Access Control (Exp\_mem\_ctl) address 0x16 (22'd)**

Bit	Bit Name	Default	Description
15	Global Reset	0, RW, SC	<b>Global Reset:</b> This bit resets the entire chip.
14:8	Reserved	0, RO	Write as 0, ignore on read.
7	Broadcast Enable	0, RW	<b>Broadcast Enable:</b> 1 = Respond to broadcast write at MDIO address 0 0 = Respond to MDIO address set in register 0x1F.4:0
6:2	Reserved	0, RO	Write as 0, ignore on read.
1:0	Address Control	[11], RW	<b>Address Control:</b> 00 = 8-bit expanded memory read/write (auto-incr disabled) 01 = 8-bit expanded memory read/write (auto-incr enabled) 10 = 16-bit expanded memory read/write (auto-incr enabled) 11 = 8-bit expanded memory write-only (auto-incr disabled)

## 2.0 Register Block (Continued)

**Table 22. Interrupt Clear Register (INT\_CLEAR) address 0x17 (23'd)**

Bit	Bit Name	Default	Description
15	spd_cng_int_clr	0, RW, SC	Setting this bit clears the spd_cng_int interrupt.
14	lnk_cng_int_clr	0, RW, SC	Setting this bit clears the lnk_cng_int interrupt.
13	dplx_cng_int_clr	0, RW, SC	Setting this bit clears the dplx_cng_int interrupt.
12	mdix_cng_int_clr	0, RW, SC	Setting this bit clears the mdix_cng_int interrupt.
11	pol_cng_int_clr	0, RW, SC	Setting this bit clears the pol_cng_int interrupt.
10	prl_detflt_int_clr	0, RW, SC	Setting this bit clears the prl_detflt_int interrupt.
9	mas_sla_err_int_clr	0, RW, SC	Setting this bit clears the mas_sla_err_int interrupt.
8	no_hcd_int_clr	0, RW, SC	Setting this bit clears the no_hcd_int interrupt.
7	no_lnk_int_clr	0, RW, SC	Setting this bit clears the no_lnk_int interrupt.
6	jabber_cng_int_clr	0, RW, SC	Setting this bit clears the jabber_cng_int interrupt.
5	nxt_pg_rcvd_int_clr	0, RW, SC	Setting this bit clears the nxt_pg_rcvd_int interrupt.
4	an_cmpl_int_clr	0, RW, SC	Setting this bit clears the an_cmpl_int interrupt.
3	rem_ftl_cng_int_clr	0, RW, SC	Setting this bit clears the rem_ftl_cng_int interrupt.
2:0	Reserved	0, RO	Write as 0, ignore on read.

**Table 23. BIST Counter Register (BIST\_CNT) address 0x18 (24'd)**

Bit	Bit Name	Default	Description
15:0	BIST Counter	0, RO	<b>BIST Counter:</b> This register counts receive packets or receive errors according to bit 15 in register BIST_CFG1. It shows either the upper or lower 16 bit of a 32 bit value which can be selected through bit 14 in register BIST_CFG2.

**Table 24. BIST Configuration Register 1 (BIST\_CFG1) address 0x19 (25'd)**

Bit	Bit Name	Default	Description
15	bist_cnt_type	0, RW	<b>Set BIST Counter Type:</b> 1 = BIST_CNT counts receive CRC errors 0 = BIST_CNT counts receive packets
14	bist_cnt_clr	0, RW, SC	<b>BIST Counter Clear:</b> Setting this bit clears the BIST_CNT register to 0.
13	tx_bist_pak_len	0, RW	<b>Transmit BIST Packet Length:</b> 1 = 1514 bytes 0 = 60 bytes
12	tx_bist_ifg	0, RW	<b>Transmit BIST Interframe Gap:</b> This bit sets the IFG for transmit BIST packets. 1 = 9.6 us 0 = 0.096us
11	tx_bist_en	0, RW, SC	<b>Transmit BIST Enable:</b> This bit starts the transmit BIST. The number of selected packets or a continuous data stream is sent out when set. This bit self-clears after the packets have been sent. 1 = Transmit BIST enabled 0 = Transmit BIST disabled

## 2.0 Register Block (Continued)

**Table 24. BIST Configuration Register 1 (BIST\_CFG1) address 0x19 (25'd)**

Bit	Bit Name	Default	Description
10	tx_bist_pak_type	0, RW	<b>Transmit BIST Packet Type:</b> 1 = PSR9 0 = User defined packet
9:8	Reserved	0, RO	Write as 0, ignore on read.
7:0	tx_bist_pak	0, RW	<b>User Defined Packet Content:</b> This field sets the packet content for the transmit BIST packets if the user defined packet type in bit 10 is selected.

**Table 25. BIST Configuration Register 2 (BIST\_CFG2) address 0x1A (26'd)**

Bit	Bit Name	Default	Description
15	rx_bist_en	0, RW	<b>Receive BIST Enable:</b> This bit enables the receive BIST counter. The BIST counter operation does not interfere with normal PHY operation. 0 = BIST counter disabled 1 = BIST counter enabled
14	bist_cnt_sel	0, RW	<b>BIST Counter Select:</b> This bit selects whether the upper or lower 16 bit of the 32 bit counter value are shown in the BIST_CNT register. 0 = displays lower 16 bit 1 = displays upper 16 bit
13:11	tx_bist_pak_cnt	0, RW	<b>Transmit BIST Packet Count:</b> Sets the number of transmit packets 000 = continuous transmit 001 = 1 packet 010 = 10 packets 011 = 100 packets 100 = 1,000 packets 101 = 10,000 packets 110 = 100,000 packets 111 = 10,000,000 packets
10:1	Reserved	0, RO	Write as 0, ignore on read.
0	Link/Link-ACT sel	0, RW	<b>Link/Link-ACT Select:</b> This bit has no impact when Reg 0x13.5 = 0. 1 = LINK only 0 = Combined Link/ACT

**Note:** Registers 0x1B and 0x1C are reserved.

**Table 26. Expanded Memory Data Register (Exp\_mem\_data) address 0x1D (29'd)**

Bit	Bit Name	Default	Description
15:0	Expanded Memory Data	0, RW	<b>Expanded Memory Data:</b> Data to be written to or read from expanded memory. Note that in 8-bit mode, the data resides at the LSB octet of this register.

**Table 27. Expanded Memory Address Register (Exp\_mem\_addr) address 0x1E (30'd)**

Bit	Bit Name	Default	Description
15:0	Expanded Memory Address	0, RW	<b>Expanded Memory Address:</b> Pointer to the address in expanded memory. The pointer is 16-bit wide.

## 2.0 Register Block (Continued)

Table 28. PHY Support Register #2 (PHY\_SUP) address 0x1F (31'd)

Bit	Bit Name	Default	Description
15:5	Reserved	0, RO	Write as 0, ignore on read.
4:0	PHY Address	STRAP[0_0001], RW	<b>PHY Address:</b> Defines the port on which the PHY will accept Serial Management accesses.



## 3.0 Configuration

This section includes information on the various configuration options available with the DP83865. The configuration options include:

- Accessing expanded memory space
- Manual configuration
  - Speed / Duplex selection
  - Forced Master / Slave
- Auto-Negotiation
  - Speed / Duplex selection
  - Gigabit speed fallback
  - Gigabit retry forced link
  - Master / Slave resolution
  - Next Page support
  - Parallel Detection
  - Pause and Asymmetrical Pause resolution
  - Restart Auto-Negotiation
  - Auto-Negotiation complete time
- Auto-Negotiation register set
- Auto-MDIX configuration
- Automatic polarity correction
- PHY address and LEDs
- Reduced LED mode
- Modulate LED on error
- MII / GMII / RGMII MAC interfaces
- Clock to MAC output
- MII / GMII /RGMII isolate mode
- Loopback mode
- IEEE 802.3ab test modes
- Interrupt
- Power down modes
  - Low power mode
  - BIST usage
  - Cable length indicator
  - 10BASE-T HDX loopback disable
  - I/O Voltage Selection
  - Non-compliant interoperability mode

The DP83865 supports six different Ethernet protocols: 10BASE-T Full Duplex and Half Duplex, 100BASE-TX Full Duplex and Half Duplex, 1000BASE-T Full Duplex and Half Duplex. There are three ways to select the speed and duplex modes, i.e. manual configuration with external strapping options or through management register write and Auto-Negotiation.

### 3.1 Accessing Expanded Memory Space

The 32 IEEE base page registers limits the number of functions and features to be accessed. The advanced proprietary features are implemented in the register located in the expanded memory space. The following are features and functions require access to expanded memory space:

- Gigabit Speed Fallback
- Gigabit Retry Forced Link
- Cable length indicator
- 10BASE-T HDX loopback

There are three registers used for accessing the expanded memory. The Expanded Memory Access Control register (0x16) sets up the memory access mode, for example, 8-bit or 16-bit data address, enable or disable automatic address increment after each access, and read/write or write-only operation. The Expanded Memory Address pointer register (0x1E) points the location of the expanded memory to be accessed. The Expanded Memory Data (0x1D) register contains the data read from or write to the expanded memory.

Note that the order of the writes to these registers is important. While register 0x1E points to the internal expanded address and register 0x1D contains the data to be written to or read from the expanded memory, the contents of register 0x1E automatically increments after each read or write to data register 0x1D when auto-increment is selected. Therefore, if data write need to be confirmed, address register 0x1E should be reloaded with the original address before reading from data register 0x1D (when auto-increment is selected).

The expanded memory space data is 8-bit wide. In the 8-bit read/write mode, the LSB 8 bits of the data register 0x1D.7:0 is mapped to the expanded memory.

The following is an example of step-by-step procedure enabling the Speed Fallback mode:

- 1) Power down the DP83865 by setting register 0x00.11 = 1. This is to ensure that the memory access does not interfere with the normal operation.
- 2) Write to register 0x16 the value 0x0000. This allows access to expanded memory for 8-bit read/write.
- 3) Write to register 0x1E the value 0x1C0.
- 4) Write to register 0x1D the value 0x0008.
- 5) Take the out of power down mode by resetting register 0x00.11.

### 3.2 Manual Configuration

For manual configuration of the speed and the duplex modes (also referred to as forced mode), the Auto-Negotiation function has to be disabled. This can be done in two ways. Strapping Auto-Negotiation Enable (AN\_EN) pin low disables the Auto-Negotiation. Auto-Negotiation can also be disabled by writing a “0” to bit 12 of the BMCR 0x00 to override the strapping option.

It should be noted that manual 1000BASE-T mode is not supported by IEEE. The DP83865, when in manual 1000BASE-T mode, only communicates with another National PHY. The manual 1000BASE-T mode is designed for test purposes only.

#### 3.2.1 Speed/Duplex Selection

In Manual mode, the strapping value of the SPEED[1:0] pins is used to determine the speed, and the strap value of the DUPLEX pin is used to determine duplex mode.

For all of the modes above, the DUPLEX strap value “1” selects Full Duplex (FD), while “0” selects Half Duplex (HD). The strap values are latched on during power-on reset and can be overwritten by access to the BMCR register 0x00 bits 13,12, 8 and 6.

### 3.0 Configuration (Continued)

**Table 29. Speed/Duplex Selection, AN\_EN = 0**

DUPLEX	SPEED[1]	SPEED[0]	Manual Mode
0	0	0	10BASE-T HD
0	0	1	100BASE-TX HD
0	1	0	1000BASE-T HD (Between National PHYs only)
0	1	1	Reserved
1	0	0	10BASE-T FD
1	0	1	100BASE-TX FD
1	1	0	1000BASE-T FD (Between National PHYs only)
1	1	1	Reserved

#### 3.2.2 Master/Slave

In 1000BASE-T the two link partner devices have to be configured, one as Master and the other as Slave. The Master device by definition uses a local clock to transmit data on the wire; the Slave device uses the clock recovered of the incoming data from the link partner for transmitting its data. The Master and Slave assignments can be manually set by using strapping options or register writes. When the AN\_EN pin is strapped low, strapping MULTI\_EN pin low selects Slave and high selects Master mode. Register 9 bits 12:11 allows software to overwrite the strapping Master/Slave setting (Table 30). Note that if both the link partner and the local device are manually given the same Master/Slave assignment, an error will occur as indicated in 1KSTSR 0x0A bit 15.

**Table 30. 1000BASE-T Master/Slave Sel., AN\_EN = 0**

MULTI_EN	Manual Mode
0	Slave mode
1	Master mode

Depending on what the link partner is configured to, the manual Master/Slave mode can be resolved to eight possible outcomes. Only two National PHYs will be able to link to each other in manual configuration mode. (Table 32)

### 3.3 Auto-Negotiation

All 1000BASE-T PHYs are required to support Auto-Negotiation. (The 10/100 Mbps Ethernet PHYs had an option to support Auto-Negotiation, as well as parallel detecting when a link partner did not support Auto-Neg.) The Auto-Negotiation function in 1000BASE-T has three primary purposes:

- Auto-Negotiation of Speed & Duplex Selection
- Auto-Negotiation of Master/Slave Resolution
- Auto-Negotiation of Pause/Asymmetrical Pause Resolution

**Table 31. Master/Slave Resolution, AN\_EN = 0**

DP83865 Advertise	Link Partner Advertise	DP83865 Outcome	Link Partner Outcome
Manual Master	Manual Master	Unresolved No Link	Unresolved No Link
Manual Master	Manual Slave	Master	Slave
Manual Master	Multi-node (Auto-neg)	Master	Slave
Manual Master	Single-node (Auto-neg)	Master	Slave
Manual Slave	Manual Master	Slave	Master
Manual Slave	Manual Slave	Unresolved No Link	Unresolved No Link
Manual Slave	Multi-node (Auto-neg)	Slave	Master
Manual Slave	Single-node (Auto-neg)	Slave	Master

The DP83865 also supports features such as:

- Next Page
- Parallel Detection for 10/100 Mbps
- Restart Auto-Negotiation through software

#### 3.3.1 Speed/Duplex Selection - Priority Resolution

The Auto-Negotiation function provides a mechanism for exchanging configuration information between the two ends of a link segment. This mechanism is implemented by exchanging Fast Link Pulses (FLP). FLP are burst pulses that provide the signalling used to communicate the abilities between two devices at each end of a link segment. For further details regarding Auto-Negotiation, refer to Clause 28 of the IEEE 802.3u specification. The DP83865 supports six different Ethernet protocols: 10BASE-T Full Duplex, 10BASE-T Half Duplex, 100BASE-TX Full Duplex, 100BASE-TX Half Duplex, 1000BASE-T Full Duplex, and 1000BASE-T Half Duplex. The process of Auto-Negotiation ensures that the highest performance protocol is selected (i.e., priority resolution) based on the advertised abilities of the Link Partner and the local device. (Table 33)

**Table 32. Master/Slave Resolution, AN\_EN = 0**

DP83865 Advertise	Link Partner Advertise	DP83865 Outcome	Link Partner Outcome
Manual Master	Manual Master	Unresolved No Link	Unresolved No Link
Manual Master	Manual Slave	Master	Slave
Manual Master	Multi-node (Auto-neg)	Master	Slave
Manual Master	Single-node (Auto-neg)	Master	Slave
Manual Slave	Manual Master	Slave	Master
Manual Slave	Manual Slave	Unresolved No Link	Unresolved No Link
Manual Slave	Multi-node (Auto-neg)	Slave	Master
Manual Slave	Single-node (Auto-neg)	Slave	Master

### 3.0 Configuration (Continued)

**Table 33. Speed/Duplex Selection, AN\_EN = 1**

DUP	Speed[1]	Speed[0]	Comments
0	0	0	1000/100/10 HDX
0	0	1	1000/100 HDX
0	1	0	1000 HDX
0	1	1	1000/10 HDX
1	0	0	1000/100/10 FDX + HDX
1	0	1	1000/100 FDX + HDX
1	1	0	1000 FDX + HDX
1	1	1	1000/10 FDX + HDX

The Auto-Negotiation priority resolution are as follows:

1. 1000BASE-T Full Duplex (Highest Priority)
2. 1000BASE-T Half Duplex
3. 100BASE-TX Full Duplex
4. 100BASE-TX Half Duplex
5. 10BASE-T Full Duplex
6. 10BASE-T Half Duplex (Lowest Priority)

#### 3.3.2 Gigabit Speed Fallback

When gigabit mode is advertised, the default auto-negotiation mode attempts to establish link at the highest common denominator advertised. However, there are situations that the cable media may not be appropriate for the gigabit speed communication. If achieving a quality link is the highest priority, the Speed Fallback Mode can be enabled. The Speed Fallback Mode allows auto-negotiation to link at the next lower speed advertised (100Mbps or 10Mbps) if the gigabit mode fails.

There are three criteria established to initiate the gigabit Speed Fallback.

1. Auto-negotiation failing to achieve a stable gigabit link
2. CRC error rate
3. Idle error rate

There are four basic control register bits used to configure the Speed Fallback. Expanded register 0x1C0.3 = 1 enables the Speed Fallback mode. LED Control Register 0x13.2:0 selects the criteria for the Speed Fallback.

**Table 34. LED Control Reg 0x13, Reg 0x1C0.3 = 1**

Bit 2, AN	Bit 1, CRC	Bit 0, IE	Comments
0	0	0	No Speed Fallback (SF)
0	0	1	SF on idle error
0	1	0	SF on CRC error
0	1	1	SF on idle and CRC
1	0	0	SF on failing AN
1	0	1	SF on AN and IE
1	1	0	SF on AN and CRC
1	1	1	SF on AN, CRC, and IE

The default for AN Speed Fallback is that after five tries to achieve a stable link, the link speed will drop down to the next lower advertised speed. The default CRC and IE Speed Fallback is that after five link drops due to increase error rate, the link speed drops down to the next lower advertised speed. If during the link retry stage that the link partner drops the link or the CAT5 cable is unplugged, the retry counter will reload the retry count with the default value of five.

Note that the Speed Fallback works only from gigabit mode to 100 Mbps or 10 Mbps.

#### 3.3.3 Gigabit Retry Forced Link

Under the situations that the cable media may not be appropriate for the gigabit transmission, it may take excessive number of retries to achieve a stable link. If achieving a stable link is the highest priority, the Retry Forced Link Mode can be enabled. Retry Forced Link Mode allows auto-negotiation to force link at the highest common link speed after five retries.

There are two criteria established to initiate the gigabit Retry Forced Link.

1. CRC error rate
2. Idle error rate

There are three basic control register bits used to configure the Speed Fallback and Retry Forced Link. Expanded register 0x1C0.3 = 0 enables the Retry Forced Link mode (i.e., the default mode upon power up). LED Control Register 0x13.1:0 selects the criteria for the Speed Fallback. Since Retry Forced Link does not work when AN fails to achieve stable link, LED Control Register 0x13.2 should be 0.

**Table 35. LED Control Reg 0x13, Reg 0x1C0.3 = 0**

Bit 2, AN	Bit 1, CRC	Bit 0, IE	Comments
0	0	0	No Retry Forced Link (RFL)
0	0	1	RFL on idle error
0	1	0	RFL on CRC error
0	1	1	RFL on idle and CRC

The default CRC and IE Retry Forced Link is that after five link drops due to increase error rate, the link will be forced at the highest advertised speed. If during the link retry stage that the link partner drops the link or the CAT5 cable is unplugged, the retry counter will reload the retry count with the default value of five. Note that the retry may take forever to achieve a forced link when link partner drops the link or CAT5 cable is unplugged.

#### 3.3.4 Master/Slave Resolution

If 1000BASE-T mode is selected during the priority resolution, the second goal of Auto-Negotiation is to resolve Master/Slave configuration. The Master mode priority is given to the device that supports multiport nodes, such as switches and repeaters. Single node devices such as DTE or NIC card takes lower Master mode priority.

MULTI\_EN is a strapping option for advertising the Multi-node functionality. (Table 36) In the case when both PHYs advertise the same option, the Master/Slave resolution is

### 3.0 Configuration (Continued)

resolved by a random number generation. See IEEE 802.3ab Clause 40.5.1.2 for more details.

**Table 36. 1000BASE-T Single/Multi-Node, AN\_EN = 1**

MULTI_EN	Forced Mode
0	Single node, Slave priority mode
1	Multi-node, Master priority mode

Depending on what link the partner is configured to, the Auto-Negotiation of Master/Slave mode can be resolved to eight possible outcomes. (Table 37)

**Table 37. Master/Slave Resolution, AN\_EN = 1**

DP83865 Advertise	Link Partner Advertise	DP83865 Outcome	Link Partner Outcome
Multi-node	Manual Master	Slave	Master
Multi-node	Manual Slave	Master	Slave
Multi-node	Multi-node	M/S resolved by random seed	M/S resolved by random seed
Multi-node	Single-node	Master	Slave
Single-node	Manual Master	Slave	Master
Single-node	Manual Slave	Master	Slave
Single-node	Multi-node	Slave	Master
Single-node	Single-node	M/S resolved by random seed	M/S resolved by random seed

#### 3.3.5 Pause and Asymmetrical Pause Resolution

When Full Duplex operation is selected during priority resolution, the Auto-Negotiation also determines the Flow Control capabilities of the two link partners. Flow control was originally introduced to force a busy station's Link Partner to stop transmitting data in Full Duplex operation. Unlike Half Duplex mode of operation where a link partner could be forced to back off by simply generating collisions, the Full Duplex operation needed a mechanism to slow down transmission from a link partner in the event that the receiving station's buffers are becoming full. A new MAC control layer was added to handle the generation and reception of Pause Frames. Each MAC Controller has to advertise whether it is capable of processing Pause Frames. In addition, the MAC Controller advertises if Pause frames can be handled in both directions, i.e. receive and transmit. If the MAC Controller only generates Pause frames but does not respond to Pause frames generated by a link partner, it is called Asymmetrical Pause.

The advertisement of Pause and Asymmetrical Pause capabilities is enabled by writing '1' to bits 10 and 11 of ANAR 0x04. The link partner's Pause capabilities is stored ANLPAR 0x05 bits 10 and 11. The MAC Controller has to read from ANLPAR to determine which Pause mode to operate. The PHY layer is not involved in Pause resolution other than simply advertising and reporting of Pause capabilities.

#### 3.3.6 Next Page Support

The DP83865 supports the Auto-Negotiation Next Page protocol as required by IEEE 802.3u clause 28.2.4.1.7. The

ANNPTR 0x07 allows for the configuration and transmission of the Next Page. Refer to clause 28 of the IEEE 802.3u standard for detailed information regarding the Auto-Negotiation Next Page function.

#### 3.3.7 Parallel Detection

The DP83865 supports the Parallel Detection function as defined in the IEEE 802.3u specification. Parallel Detection requires the 10/100 Mbps receivers to monitor the receive signal and report link status to the Auto-Negotiation function. Auto-Negotiation uses this information to configure the correct technology in the event that the Link Partner does not support Auto-Negotiation, yet is transmitting link signals that the 10BASE-T or 100BASE-X PMA recognize as valid link signals.

If the DP83865 completes Auto-Negotiation as a result of Parallel Detection, without Next Page operation, bits 5 and 7 of ANLPAR 0x05 will be set to reflect the mode of operation present in the Link Partner. Note that bits 4:0 of the ANLPAR will also be set to 00001 based on a successful parallel detection to indicate a valid 802.3 selector field. Software may determine that the negotiation is completed via Parallel Detection by reading '0' in bit 0 of ANER 0x06 after the Auto-Negotiation Complete bit (bit 5, BMSR 0x01) is set. If the PHY is configured for parallel detect mode and any condition other than a good link occurs, the parallel detect fault bit will set (bit 4, ANER 0x06).

#### 3.3.8 Restart Auto-Negotiation

If a link is established by successful Auto-Negotiation and then lost, the Auto-Negotiation process will resume to determine the configuration for the link. This function ensures that a link can be re-established if the cable becomes disconnected and re-connected. After Auto-Negotiation is completed, it may be restarted at any time by writing '1' to bit 9 of the BMCR 0x00.

A restart Auto-Negotiation request from any entity, such as a management agent, will cause DP83865 to halt data transmission or link pulse activity until the break\_link\_timer expires (~1500 ms). Consequently, the Link Partner will go into link fail mode and the resume Auto-Negotiation. The DP83865 will resume Auto-Negotiation after the break\_link\_timer has expired by transmitting FLP (Fast Link Pulse) bursts.

#### 3.3.9 Enabling Auto-Negotiation via Software

If the DP83865 is initialized upon power-up with Auto-Negotiation disabled (forced technology) and the user may desire to restart Auto-Negotiation, this could be accomplished by software access. Bit 12 of BMCR 0x00 should be cleared and then set for Auto-Negotiation operation to take place.

#### 3.3.10 Auto-Negotiation Complete Time

Parallel detection and Auto-Negotiation take approximately 2-3 seconds to complete. In addition, Auto-Negotiation with next page exchange takes approximately 2-3 seconds to complete, depending on the number of next pages exchanged.

Refer to Clause 28 of the IEEE 802.3u standard for a full description of the individual timers related to Auto-Negotiation.

### 3.0 Configuration (Continued)

#### 3.4 Auto-Negotiation Register Set

The strapping option settings of Auto-Negotiation, speed, and duplex capabilities that initialized during power-up or at reset can be altered any time by writing to the BMCR 0x00, ANAR 0x04 or, to 1KTCR 0x09.

When Auto-Negotiation is enabled, the DP83865 transmits the abilities programmed in the ANAR 0x04, and 1KTCR 0x09 via FLP Bursts. The following combinations of 10 Mbps, 100 Mbps, 1000 Mbps, Half Duplex, and Full Duplex modes may be selected.

**Table 38. Advertised Modes during Auto-Negotiation, AN\_EN = 1**

SPEED1	SPEED0	DUPLEX	Adertised Modes
1	1	0	1000BASE-T HD, 10BASE-T HD
1	0	0	1000BASE-T HD
0	1	0	1000BASE-T HD, 100BASE-TX HD
0	0	0	1000BASE-T HD, 100BASE-TX HD, 10BASE-T HD
1	1	1	1000BASE-T FD, 10BASE-T FD
1	0	1	1000BASE-T FD
0	1	1	1000BASE-T FD, 100BASE-TX FD
0	0	1	1000BASE-T FD, 100BASE-TX FD, 10BASE-T FD

The Auto-Negotiation protocol compares the contents of the ANLPAR (received from link partner) and ANAR registers (for 10/100 Mbps operation) and the contents of 1000BASE-T status and control registers, and uses the results to automatically configure to the highest performance protocol (i.e., the highest common denominator) between the local and the link partner. The results of Auto-Negotiation may be accessed in registers BMCR 0x00 (Duplex Status and Speed Status), and BMSR 0x01 (Auto-Neg Complete, Remote Fault, Link).

The BMCR 0x00 provides control for enabling, disabling, and restarting the Auto-Negotiation process.

The BMSR 0x01 indicates the set of available abilities for technology types, Auto-Negotiation ability, and extended register capability. These bits are permanently set to indicate the full functionality of the DP83865. The BMSR also provides status on:

- Auto-Negotiation is completed on bit 5
- The Link Partner is advertising that a remote fault has occurred on bit 4
- A valid link has been established on bit 2

The ANAR 0x04 stores the capabilities advertised during Auto-Negotiation. All available capabilities are transmitted by default. However, the advertised capability can be suppressed by writing to the ANAR. This is a commonly used by a management agent to change (i.e., to force) the communication technology.

The ANLPAR 0x05 is used to store the received base link code word as well as all next page code words during the negotiation that is transmitted from the link partner.

If Next Page is NOT being used, then the ANLPAR will store the base link code word (link partner's abilities) and retain this information from the time the page is received, indicated by a '1' in bit 1 of the ANER 0x06, through the end of the negotiation and beyond.

During the next page exchange operation, the station manager can not wait till the end of Auto-Negotiation to read the ANLPAR because the register is used to store both the base and next pages. The next page content overwrites the base page content. The station manager needs to closely monitor the negotiation status and to perform the following tasks.

- ANER 0x06 bit 1 is '1' indicates a page is received. Station manager reads the base page information from ANLPAR0x05 and stores the content in the memory.
- After reading the base page information, software needs to write to ANNPTR 0x07 to load the next page information to be sent.
- The operation can be implemented as polled or interrupt driven. If another page is received by polling bit 1 in the ANER 0x06 or by interrupt, the station manager reads bit 15 of the ANLPAR indicating the partner has more next pages to send. If the partner has more pages to send, ANNPTR needs to be written to load another next page.

The ANER 0x06 indicates additional Auto-Negotiation status. The ANER provides status on:

- A Parallel Detect Fault has occurred (bit 4, ANER 0x06).
- The Link Partner supports the Next Page function (bit 3, ANER 0x06).
- The DP83865 supports the Next Page function (bit 2, ANER 0x06).
- The current page being exchanged by Auto-Negotiation has been received (bit1, ANER 0x06).
- The Link Partner supports Auto-Negotiation (bit 0, ANER 0x06).

The ANNPTR 0x07 contains the next page code word to be transmitted. See also Section "2.3 Register Description" for details.

#### 3.5 Auto-MDIX resolution

The GigPHYTER V can determine if a "straight" or "cross-over" cable is used to connect to the link partner. It can automatically re-assign channel A and B to establish link with the link partner, (and channel C and D in 1000BASE-T mode). Auto-MDIX resolution precedes the actual Auto-Negotiation process that involves exchange of FLPs to advertise capabilities. Automatic MDI/MDIX is described in IEEE 802.3ab Clause 40, section 40.8.2. It is not a required implementation for 10BASE-T and 100BASE-TX.

**Table 39. PMA signal to MDI and MDIX pin-out**

Contact	MDI	MDIX
1	MDI_A+	MDI_B+
2	MDI_A-	MDI_B-
3	MDI_B+	MDI_A+
4	MDI_C+	MDI_D+
5	MDI_C-	MDI_D-
6	MDI_B-	MDI_A-
7	MDI_D+	MDI_C+
8	MDI_D-	MDI_C-

### 3.0 Configuration (Continued)

To enable Auto-MDIX, strapping option pin MDIX\_EN should be pulled up or left floating. Auto-MDIX can be disabled by strapping MDIX\_EN pin low. When Auto-MDIX is disabled, the PMA is forced to either MDI ("straight") or MDIX ("crossed") - according to the setting of the MAN\_MDIX strapping option pin (high for MDIX and low for MDI).

The two strapping options for the MDI/MDIX configuration can be overwritten by writing to bits 14 and 15 of register AUX\_CTRL (0x12). Bit 15 disables the Auto-MDIX feature and bit 14 can change the straight/crossed and MDI/MDIX setting.

Auto-MDIX is independent of Auto-Negotiation. Auto-MDIX works in both AN mode and manual forced speed mode. The Auto-MDIX in forced speed mode is added to DP83865DVH revision and up.

### 3.6 Polarity Correction

The GigPHYTER V will automatically detect and correct for polarity reversal in wiring between the +/- wires for each pair of the 4 ports.

The current status of the polarity reversals is displayed in bit 15:12 of register LINK\_AN (0x11).

### 3.7 PHY Address, Strapping Options and LEDs

The PHY address can be set through external strapping resistors. If all PHY address pins are left floating, the PHY address is defaulted to 01h by internal pull up/down resistors.

The PHY address of DP83865 port can be configured to any of the 31 possible PHY addresses (except 00h which puts the PHY in isolation mode at power-up). However, if more than one DP83865 is used on a board and if MDIO is used in a system, each of the DP83865's address must be different.

PHY address strapping pin "0" is shared with the Duplex LED pin.

Strap option pins can be left floating which will result in the default for the particular pin to be set. External pull-up or pull-down resistors (2kΩ recommended) can be used to change the pre-set value.

The state of the strapping option pin inputs is latched (into Strap\_reg 0x10) at system power-on or reset. For further details relating to the latch-in timing requirements of the strapping option pins, as well as the other hardware configuration pins, refer to section "6.2 Reset Timing" on page 73.

Some strap option pins are shared with LED output pins. Since the strapping resistor could be a pull-up or a pull-down, an adaptive mechanism has been implemented to simplify the required external circuit. In case the LED/strapping pin is strapped high, the LED drive level is active low. In case the LED/strapping pin is strapped low, the LED drive level is active high. See section "5.9 LED/Strapping Option" on page 67 for details of the recommended external components.

### 3.8 Reduced LED Mode

The DP83865DVH has a standard five-LED set. In some applications, it is desirable to use fewer LED's. The "reduced LED mode" (RLED) is created to accommodate the need for combining the LED functions into fewer LED's

and it is implemented on DP83865DVH. Note that the reduced LED mode is in addition to the existing five-LED mode.

There are two reduced LED modes, the 3-in-1 mode and the 4-in-1 mode. The 3-in-1 mode combines 10/100/100 Mbps links status in one LED, the standard LINK10\_LED. In the 3-in-1 mode, the rest of the four LED's would still function in the standard mode. This would allow user to use one LED to indicate three-speed links, and other LED's to indicate 1000M link, TX/RX activity, or duplex.

Similar to 3-in-1 mode, the 4-in-1 mode combines an additional activity into the three-speed link modes. This mode would further reduce the number of LED's and still keep the same number of display types.

To enable the RLED mode, LED Control Register 0x13.5 = 1, and register 0x1A.0 selects 3-in-1 or 4-in-1 mode.

Table 40. Reduced LED Mode

RLED Ena	3/4-in-1 Sel	LINK10_LED
0	0	10M link
0	1	10M link
1	0	10/100/1000 link and ACT
1	1	10/100/1000 link

### 3.9 Modulate LED on Error

The DP83865DVH uses ACT LED to display activity under normal operation. The ACT LED is steady on when there is Tx or Rx activity. The ACT can also display gigabit idle error and CRC event. To differentiate ACT LED from normal Tx/Rx activity, the rate of the blink is faster when error occurs. To enable the idle error modulation, LED Control Register 0x13.3 = 1 and to enable CRC error modulation, 0x13.4 = 1.

Table 41. LED Control Reg 0x13

Bit 4	Bit 3	Activity LED
0	0	Normal ACT
0	1	ACT/Idle error
1	0	ACT/CRC error
1	1	ACT/Idle error/CRC error

### 3.10 MAC Interface

The DP83865 MAC interface can be configured to one of the following different modes:

- MII Mode: Supports 10/100 Mbps MACs.
- GMII Mode: Supports 802.3z compliant 1000 Mbps MACs.
- RGMII Mode: Supports RGMII version 1.3.

Only one mode is used at a time.

The interface is capable of driving 35 pF under worst conditions. Note that these outputs are not designed to drive multiple loads, connectors, backplanes, or cables. See section "5.6 Layout Notes on MAC Interface" on page 66 for design and layout details.

## 3.0 Configuration (Continued)

### 3.10.1 MII/GMII Interface

The link speed is determined by Auto-Negotiation, by strapping options, or by register writes. Based on the speed linked, an appropriate MAC interface is enabled.

**Table 42. Auto-Negotiation Disabled**

SPEED[1:0]	Link Strapped	Controller I/F
00	10BASE-T	MII
01	100BASE-TX	MII
10	1000BASE-T	GMII/RGMII
11	reserved	---

**Table 43. Auto-Negotiation Enabled**

Link Negotiated	Controller I/F
10BASE-T	MII
100BASE-TX	MII
1000BASE-T	GMII/RGMII

### 3.10.2 RGMII Interface

The Reduced Gigabit Media Independent Interface (RGMII) is a proposed standard by HP and 3Com. RGMII is an alternative data interface to GMII and MII. RGMII reduces the MAC interface pin count to 12.

The RGMII can be enabled either through strapping option or MDIO register write. The strapping pins are shared with CRS/RGMII\_SEL0 and TX\_CLK/RGMII\_SEL1 since CRS and TX\_CLK signals are not used in the RGMII mode.

**Table 44. RGMII Strapping for HP mode**

Signal	Pin	Strap
CRS/RGMII_SEL0	40	0
TX_CLK/RGMII_SEL1	60	1

**Table 45. RGMII Strapping for 3COM mode**

Signal	Pin	Strap
CRS/RGMII_SEL0	40	1
TX_CLK/RGMII_SEL1	60	1

To enable RGMII through software, Register AUX\_CTL 0x12.13:12 should be "10" or "11" binary. Note that enabling the RGMII interface disables GMII and MII interfaces.

### 3.11 Clock to MAC Enable

The DP83865 has a clock output (pin 85) that can be used as a reference clock for other devices such as MAC or switch silicon. The Clock to MAC output can be enabled through strapping pins.

The Clock to MAC Enable Strap (pin 88) enables the clock output. The output frequency can be selected between 25 MHz or 125 MHz. The frequency selection strapping pin is combined with COL (pin 39), CLK\_MAC\_FRQ.

Note that upon power up, the clock output is available after GPHY goes through its internal reset and initialization process. The clock output can be interrupted when GPHY is going through software reset.

### 3.12 MII/GMII/RGMII Isolate Mode

The DP83865 can be placed into MII/GMII/RGMII Isolate mode by writing to bit 10 of the BMCR 0x00.

#### 3.12.1 10/100 Mbps Isolate Mode

In Isolation Mode, the DP83865 does not respond to packet data present at TXD[3:0], TX\_EN, and TX\_ER inputs and presents a high impedance on the TX\_CLK, RX\_CLK, RX\_DV, RX\_ER, RXD[3:0], COL, and CRS outputs. The DP83865 will continue to respond to all management transactions through MDIO.

While in Isolate mode, all medium access operations are disabled.

#### 3.12.2 1000 Mbps Isolate Mode

During 1000 Mbps operation, the isolate mode will TRI-STATE the GMII outputs of the GigPHYTER V. The PHY also enters into the power down mode. All medium access operations are halted. The only way to communicate to the PHY is through MDIO management port.

### 3.13 Loopback Mode

The DP83865 includes a Loopback Test mode for easy board diagnostics. The Loopback mode is selected through bit 14 (Loopback) of BMCR 0x00. Writing 1 to this bit enables MII/GMII transmit data to be routed to the MII/GMII receive outputs. While in Loopback mode the data will not be transmitted onto the media. This is true for 10Mbps, 100 Mbps, as well 1000 Mbps data.

In 10BASE-T, 100BASE-TX, 1000BASE-T Loopback mode the data is routed through the PCS and PMA layers into the PMD sublayer before it is looped back. Therefore, in addition to serving as a board diagnostic, this mode serves as quick functional verification of the device.

### 3.14 IEEE 802.3ab Test Modes

IEEE 802.3ab specification for 1000BASE-T requires that the PHY layer be able to generate certain well defined test patterns on TX outputs. Clause 40 section 40.6.1.1.2 "Test Modes" describes these tests in detail. There are four test modes as well as the normal operation mode. These modes can be selected by writing to the 1KTCR 0x09 as shown.

**Table 46. IEEE Test Mode Select**

bit 15	bit 14	bit 13	Test Mode Selected
1	0	0	= Test Mode 4
0	1	1	= Test Mode 3
0	1	0	= Test Mode 2
0	0	1	= Test Mode 1
0	0	0	= Normal Operation

### 3.0 Configuration (Continued)

See IEEE 802.3ab section 40.6.1.1.2 “Test modes” for more information on the nature of the test modes.

The DP83865 provides a test clock synchronous to the IEEE test patterns. The test patterns are output on the MDI pins of the device and the test clock is output on the TX\_TCLK pin. There are also two support signals available which are intended to improve the viewability of the test patterns on an oscilloscope. TX\_TRIGGER marks the start of the test pattern and TX\_SYNC\_CLK provides an additional clock. Refer to section “1.6 Device Configuration and LED Interface” on page 8 for pin numbers.

TX\_TCLK, TX\_TRIGGER and TX\_SYNC\_CLK must be enabled through bits 6 and 7 of register AUX\_CTRL (0x12) before they can be used.

#### 3.15 Interrupt

The DP83865 can be configured to generate an interrupt on pin 3 when changes of internal status occur. The interrupt allows a MAC to act upon the status in the PHY without polling the PHY registers. The interrupt source can be selected through the interrupt register set. This register set consists of:

- Interrupt Status Register (INT\_STATUS 0x14)
- Interrupt Mask Register (INT\_MASK 0x15)
- Interrupt Clear Register (INT\_CLEAR 0x17)

Upon reset, the interrupt is disabled and the interrupt registers are cleared. Any interrupt source can be enabled in the INT\_MASK register.

The interrupt pin is active low. When the interrupt signal is asserted it will remain asserted until the corresponding status bit is cleared.

The interrupt pin is tri-stated when the interrupt is not enabled or no interrupt has occurred.

The status bits are the sources of the interrupt. These bits are mapped in INT\_STATUS. When the interrupt status bit is “1”, the interrupt signal is asserted if the corresponding INT\_MASK bit is enabled. An interrupt status bit can be cleared by writing a “1” to the corresponding bit in INT\_CLEAR. The clear bit returns to “0” automatically after the interrupt status bit is cleared.

#### 3.16 Low Power Mode / WOL

The GigPHYTER V supports the Wake on LAN (WOL) feature of a higher layer device. In order to achieve the least possible power consumption the DP83865 must be put in 10BASE-T mode (Half or Full Duplex). In this mode the device uses a maximum of 146mW of power.

#### 3.17 Power Down Mode

Register BMCR (0x00) bit 11 puts the GigPHYTER V in Power Down mode. Writing a ‘1’ to this location causes the DP83865 to deactivate everything but the management (MDC / MDIO) interface. During this mode the device consumes the least possible power.

#### 3.18 BIST Configuration

The BIST (Built-In Self Test) provides a test interface that allows to evaluate receive performance and to generate valid transmit packets. Registers 0x18 (BIST\_CNT), 0x19 (BIST\_CFG1) and 0x1A (BIST\_CFG2) contain the controls to two distinct BIST functions: Receive BIST and transmit

BIST. The receive BIST contains a receive error counter and receive packet counter and the transmit BIST is used to generate Ethernet packets.

The BIST can be used to verify operations of all three speed modes. The speed mode can be established through auto-negotiation or manual forced mode. The BIST may also be used in combination with the loopback mode to verify both the transmit and receive operations of the physical layer device.

##### Receive BIST

BIST\_CNT displays the upper or lower 16-bit of an internal 32-bit counter. Bit 14 of BIST\_CFG2 (bist\_cnt\_sel) selects which 16-bit portion is shown while bit 15 of BIST\_CFG1 (bist\_cnt\_type) selects whether the receive packet counter or the receive error counter is active. The active counter can be cleared by writing a ‘1’ to bit 14 of BIST\_CFG1. The receive BIST counter is disabled by default and can be enabled through bit 15 of BIST\_CFG2.

The receive BIST can be enabled during normal operation in order to monitor the incoming data stream. The BIST operation will not affect the PHY’s performance or behavior.

##### Transmit BIST

The transmit BIST allows the generation of packets with pseudo-random (PSR9) or user defined content (bit 10 of BIST\_CFG1), different packet lengths (bit 13 of BIST\_CFG1) and variable interframe gap (bit 12 of BIST\_CFG1). Bits 7:0 of BIST\_CFG1 contain the content of the packet as defined by the user if that option has been chosen.

The number of packets to be sent are specified through bits 13:11 of BIST\_CFG2. Setting the enable bit in bit 11 of BIST\_CFG1 starts the transmittal. After the last packet was sent this bit is automatically cleared. In case the ‘continuous transmit’ has been selected the enable bit must be cleared in order to stop the stream of packets.

**Table 47. BIST Configuration 1 Reg (0x19)**

Bit	Function
15	Set active counter: ‘1’ = Receive error counter ‘0’ = Receive packet counter
14	‘1’ = Clear counter
13	Packet length: ‘1’ = 1514 bytes ‘0’ = 60 bytes
12	Interframe gap: ‘1’ = 9.6 $\infty$ s ‘0’ = 0.096 $\infty$ s
11	‘1’ = Enable transmit BIST
10	Packet type: ‘1’ = PSR9 ‘0’ = User defined
7:0	User defined packet content.



### 3.0 Configuration (Continued)

During transmit BIST operation the transmit path (TXD[7:0]) of the GMII / MII is disabled. All generated packets will be sent out to the MDI path unless the loopback mode is enabled. In that case the generated packets will be presented at the receive path (RXD[7:0]) of the GMII / MII.

**Table 48. BIST Configuration 2 Reg (0x1A)**

Bit	Function
15	'1' = Enable counter
14	Counter selection: '1' = upper 16-bit '0' = lower 16-bit
13:11	Number of packets to transmit: '000' = continuous transmit '001' = 1 packet '010' = 10 packets '011' = 100 packets '100' = 1,000 packets '101' = 10,000 packets '110' = 100,000 packets '111' = 10,000,000 packets

If BIST is operating the 1000BASE-T mode, active GTX\_CLK is required for the operation.

#### 3.19 Cable Length Indicator

The maximum CAT5 cable length specified in IEEE 802.3 is 100 meters. When cable length extended beyond the IEEE specified range, bit error rate (BER) will increase due to the degradation of signal-to-noise ratio. The DP83865 has enough margin built-in to work at extended cable reach.

When a 100BASE-TX or 1000BASE-T link is established, the cable length is determined from adaptation parameters. In 100BASE-TX mode, one cable length measurement is available since there is one receive channel. In 1000BASE-T mode, four cable length measurements are available since there are four receive channels. Each measurement is stored in an 8-bit register in the expanded memory space. User may choose to take the average of four measurement to achieve more accurate result. The number stored in the cable length registers are in meters, and the typical accuracy is  $\pm 5$  meters.

**Table 49. Cable Length Indicator Registers**

Registers	Addr	Description
Length_A	0x019F	Length, 100/1000 Mbps
Length_B	0x01A2	Length, 1000 Mbps
Length_C	0x01A5	Length, 1000 Mbps
Length_D	0x01A8	Length, 1000 Mbps

The error rate may be used in conjunction with the cable length measurement to determine if the link is within IEEE specifications. If the measurement shows that the cable length exceeds 130 meters, either the cable is too long or the cable quality is not meeting the CAT5 standard.

#### 3.20 10BASE-T Half Duplex Loopback

By default, the 10BASE-T half duplex transmitted packets are looped back to the receive side. This is a legacy implementation. However, in the latest MAC or switch design, the 10 Mbps loopback is desired to be turned off. The 10 Mbps HDX loopback can be disabled in the expanded memory register 0x1C0.1.

**Table 50. 10M FDX Loopback Disable, Reg 0x1C0**

Bit 1	10BASE-T HDX Loopback Mode
0	10BASE-T HDX loopback enabled
1	10BASE-T HDX loopback disabled

#### 3.21 I/O Voltage Selection

There are two options for the I/O voltage available. All IO\_VDD pins must be connected to the same power supply. It can either be 2.5V or 3.3V. The VDD\_SEL pin must be connected to ground in order to select 2.5V or to the 3.3V power supply to select 3.3 V. This pin must be connected directly to the respective power supply and must not use a pull-up/-down resistor.

Pin which are effected by IO\_VDD, i.e. will be driven at a different voltage level, are all pin on the GMII/MII interface, management interface, JTAG interface, clock interface, device configuration and reset pins.

#### 3.22 Non-compliant inter-operability mode

In this mode the DP83865 allows with other vendor's first generation 1000 Mbps PHYs. National's DP83865 is compliant to IEEE 802.3ab and optionally inter-operable with non-compliant PHYs.

To enter non-compliant inter-operability mode the user can use a 2k $\Omega$  resistor on NON\_IEEE\_STRAP (pin 1) or write '1' to bit 9 of register 0x12.

The non-compliant mode is functional in auto-negotiation configuration. It is not applicable in manual speed configuration.

## 4.0 Functional Description

The DP83865 is a full featured 10/100/1000 Ethernet Physical layer (PHY) chip. It consists of a digital 10/100/1000 Mb/s core with a common TP interface. It also has a combined versatile MAC interface that is capable of interfacing with MII and GMII controller interfaces. In this section, the following topics are covered:

- 1000BASE-T PCS Transmitter
- 1000BASE-T PMA Transmitter
- 1000BASE-T PMA Receiver
- 1000BASE-T PCS Receiver
- Gigabit MII (GMII)
- Reduced GMII (RGMII)
- 10BASE-T and 100BASE-TX Transmitter
- 10BASE-T and 100BASE-TX Receiver
- Media Dependent Interface (MII)

The 1000BASE-T transceiver includes PCS (Physical Coding Sublayer) Transmitter, PMA (Physical Medium Attachment) Transmitter, PMA Receiver and PCS Receiver. The 1000BASE-T functional block diagram is shown in section “Block Diagram” on page 2.

### 4.1 1000BASE-T PCS Transmitter

The PCS transmitter comprises several functional blocks that convert the 8-bit  $TxD_n$  data from the GMII to PAM-5 symbols passed onto the PMA function. The block diagram of the PCS transmitter data path in Figure 2 provides an overview of each of the architecture within the PCS transmitter.

The PCS transmitter consists of eight sub blocks:

- LFSR (Linear Feedback Shift Register)
- Data scrambler and symbol sign scrambler word generator
- Scrambler bit generator
- Data scrambler
- Convolutional encoder
- Bit-to-symbol quinary symbol mapping
- Sign scrambler nibble generator
- Symbol sign scrambler

The requirements for the PCS transmit functionality are also defined in the IEEE 802.3ab specification section 40.3.1.3 “PCS Transmit function”.

#### 4.1.1 Linear Feedback Shift Register (LFSR)

The side-stream scrambler function uses a LFSR implementing one of two equations based on the mode of operation, i.e., a master or a slave. For master operation, the equation is

$$g_M(x) = 1 + x^{13} + x^{33}$$

For slave operation, the equation is

$$g_S(x) = 1 + x^{20} + x^{33}$$

The 33-bit data output,  $Scr_n[32:0]$ , of this block is then fed to the data scrambler and symbol sign scrambler word generator.

#### 4.1.2 Data and Symbol Sign Scrambler Word Generator

The word generator uses the  $Scr_n[32:0]$  to generate further scrambled values. The following signals are generated:  $Sx_n[3:0]$ ,  $Sy_n[3:0]$ , and  $Sg_n[3:0]$ .

The 4-bit  $Sx_n[3:0]$  and  $Sy_n[3:0]$  values are then sent to the scrambler bit generator. The 4-bit  $Sg_n[3:0]$  sign values are provided to the sign scrambler nibble generator.

#### 4.1.3 Scrambler Bit Generator

This sub block uses the  $Sx_n$  and  $Sy_n$  signals along with the  $tx\_mode$  and  $tx\_enable$  signals to generate the  $Sc_n[7:0]$ , that is further scrambled based on the condition of the  $tx\_mode$  and  $tx\_enable$  signal. The  $tx\_mode$  signal indicates sending idles (SEND\_I), sending zeros (SEND\_Z) or sending idles/data (SEND\_N). The  $tx\_mode$  signal is generated by the micro controller function. The  $tx\_enable$  signal is either asserted to indicate data transmission is occurring or deasserted when there is no data transmission. The PCS Data Transmission Enable state machine generates the  $tx\_enable$  signal.

The 8-bit  $Sc_n[7:0]$  signals are then passed onto the data scrambler functional block.

#### 4.1.4 Data Scrambler

The Data Scrambler generates scrambled data by accepting the  $TxD_n[7:0]$  data from the GMII and scrambling it based on various inputs.

The data scrambler generates the 8-bit  $Sd_n[7:0]$  value, which scrambles the  $TxD_n$  data based primarily on the  $Sc_n$  values and the accompanying control signals.

All 8-bits of  $Sd_n[7:0]$  are passed onto the bit-to-quinary symbol mapping block, while 2-bits,  $Sd_n[7:6]$ , are fed into the convolutional encoder.

#### 4.1.5 Convolutional Encoder

The encoder uses  $Sd_n[7:6]$  bits and  $tx\_enable$  to generate an additional data bit, which is called  $Sd_n[8]$ .

The one clock delayed versions  $cs_{n-1}[1:0]$  are passed to the data scrambler block. This  $Sd_n[8]$  bit is then passed to the bit-to-symbol quinary symbol mapping function.

#### 4.1.6 Bit-to-Symbol Quinary Symbol Mapping

This block implements the IEEE 802.3ab specification Tables 40-1 and 40-2 Bit-to-Symbol Mapping for even and odd subsets. It takes the 9-bit  $Sd_n[8:0]$  data and converts it to the appropriate quinary symbols as defined by the tables.

The output of this block generates the  $TA_n$ ,  $TB_n$ ,  $TC_n$ , and  $TD_n$  symbols that passed onto the symbol sign scrambler.

#### 4.1.7 Sign Scrambler Nibble Generator

Sign Scrambler Nibble Generator performs some further scrambling of the sign values  $Sg_n[3:0]$  that are generated by the data and symbol sign scrambler word generator. The sign scrambling is dependent on the  $tx\_enable$  signal.

The  $S_nA_n$ ,  $S_nB_n$ ,  $S_nC_n$ , and  $S_nD_n$  outputs are then passed onto the symbol sign scrambler function.

## 4.0 Functional Description (Continued)

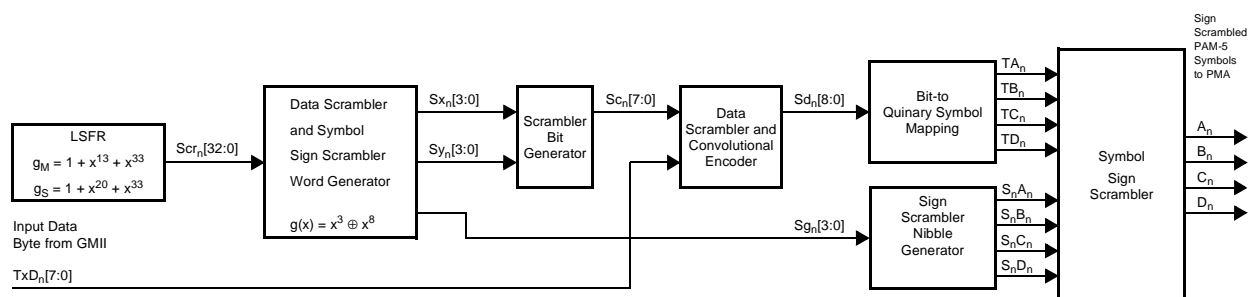

Figure 2. PCS TX Functional Block Diagram

### 4.1.8 Symbol Sign Scrambler

Symbol Sign Scrambler scrambles the sign of the  $TA_n$ ,  $TB_n$ ,  $TC_n$ , and  $TD_n$  input values from the bit-to-symbol quinary symbol mapping function by either inverting or not inverting the signs. This is done as follows:

$$A_n = TA_n \times S_nA_n$$

$$B_n = TB_n \times S_nB_n$$

$$C_n = TC_n \times S_nC_n$$

$$D_n = TD_n \times S_nD_n$$

The output of this block, namely  $A_n$ ,  $B_n$ ,  $C_n$ , and  $D_n$ , are the sign scrambled PAM-5 symbols. They are then passed onto the PMA for further processing.

### 4.2 100BASE-T PMA Transmitter

The PMA transmit block shown in Figure 3 contains the following blocks:

- Partial Response Encoder
- DAC and Line Driver

#### 4.2.1 Partial Response Encoder

Partial Response (PR) coding (or shaping) is used on the PAM-5 coded signals to spectrally shape the transmitted PAM-5 signal in order to reduce emissions in the critical frequency band ranging from 30 MHz to 60 MHz. The PR Z-transform implemented is

$$0.75 + 0.25 Z^{-1}$$

The PR coding on the PAM-5 signal results in 17-level PAM-5 or PAM-17 signal that is used to drive a common 10/100/1000 DAC and line driver. (Without the PR coding each signal can have 5 levels given by  $\pm 1$ ,  $\pm 0.5$  and 0 V. If all combinations of the 5 levels are used for the present and previous outputs, then there are 17 unique output levels when PR coding is used.)

Figure 3 shows the PMA Transmitter and the embedded PR encoder block with its inputs and outputs. Figure 4 shows the effect on the spectrum of PAM-5 after PR shaping.

#### 4.2.2 DAC and Line Driver

The PAM-17 information from the PR encoder is supplied to a common 10/100/1000 DAC and line driver that converts digitally encoded data to differential analog voltages.

### 4.3 100BASE-T PMA Receiver

The PMA Receiver (the “Receiver”) consists of several sub functional blocks that process the four digitized voltage waveforms representing the received quartet of quinary PAM-5 symbols. The DSP processing implemented in the receiver extracts a best estimate of the quartet of quinary symbols originated by the link partner and delivers them to the PCS Receiver block for further processing. There are four separate Receivers, one for each twisted pair.

The main processing sub blocks include:

- Adaptive Equalizer
- Echo and Crosstalk Cancellers
- Automatic Gain Control (AGC)
- Baseline Wander (BLW) Correction
- Slicer

#### 4.3.1 Adaptive Equalizer

The Adaptive Equalizer compensates for the frequency attenuation characteristics which results from the signal distortion of the CAT-5 cable. The cable has higher attenuates at the higher frequencies and this attenuation must be equalized. The Adaptive Equalizer is a digital filter with tap coefficients continually adapted to minimize the Mean Square Error (MSE) value of the slicer's error signal output. Continuous adaptation of the equalizer coefficients means that the optimum set of coefficients will always be achieved for maximum specified length or lower quality of cable.

#### 4.3.2 Echo and Crosstalk Cancellers

The Echo and Crosstalk Cancellers cancel the echo and crosstalk produced while transmitting and receiving simultaneously. Echo is produced when the transmitted signal interferes with the received signal on the same wire pair. Crosstalk is caused by the transmitted signal appearing on each of the other three wire pairs interfering with the receive signal on the fourth wire pair. An Echo and Crosstalk Canceller is needed for each of the wire pairs.

#### 4.3.3 Automatic Gain Control (AGC)

The Automatic Gain Control acts upon the output of the Echo and Crosstalk Cancellers to adjust the receiver gain. Different AGC methods are available within the chip and the optimum gain is selected based on the operational state the chip (master, slave, start-up, etc.).

## 4.0 Functional Description (Continued)

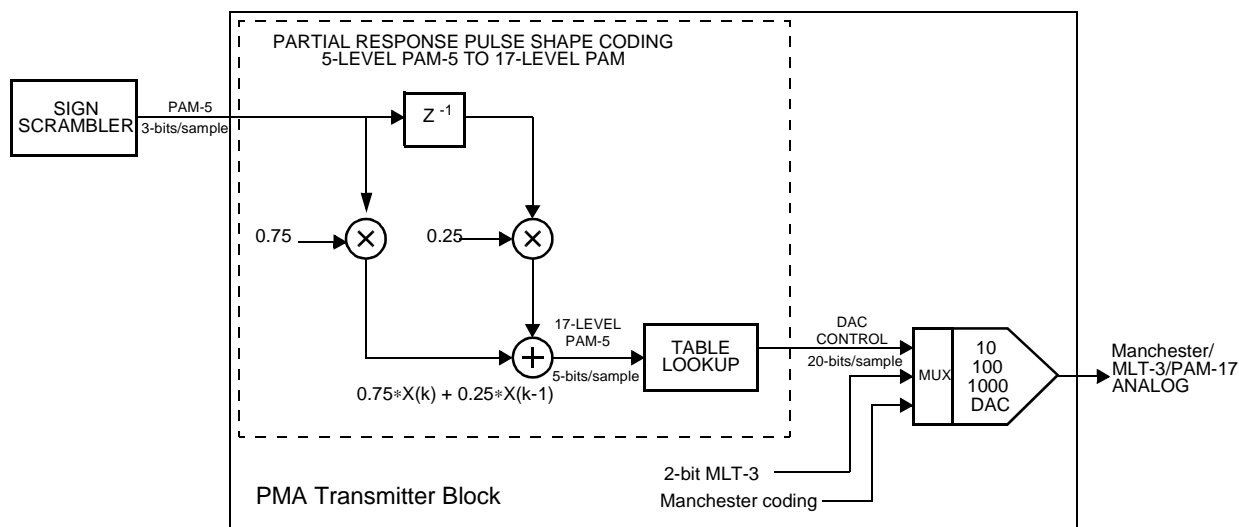

Figure 3. PMA Transmitter Block

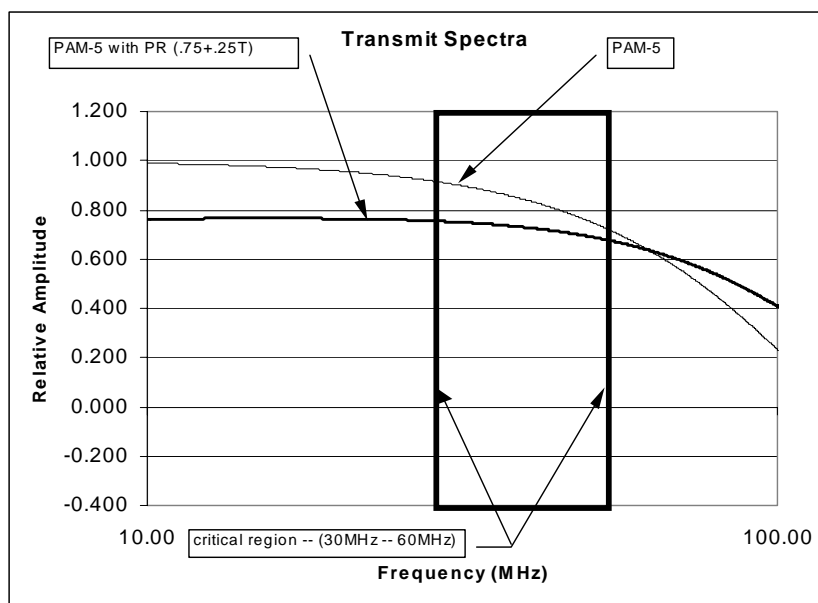

Figure 4. Effect on Spectrum of PR-shaped PAM-5 coding

### 4.3.4 Baseline Wander (BLW) Correction

Baseline wander is the slow variation of the DC level of the incoming signal due to the non-ideal electrical characteristics of the magnetics and the inherent DC component of the transmitted waveform. The BLW correction circuit utilizes the slicer error signal to estimate and correct for BLW.

### 4.3.5 Slicer

The Slicer selects the PAM-5 symbol value (+2,+1,0,-1,-2) closest to the voltage input value after the signal has been corrected for line Inter Symbol Interference (ISI), attenuation, echo, crosstalk and BLW.

The slicer produces an error output and symbol value decision output. The error output is the difference between the

actual voltage input and the ideal voltage level representing the symbol value. The error output is fed back to the BLW, AGC, Crosstalk Canceller and Echo Canceller sub blocks to be used in their respective algorithms.

### 4.4 1000BASE-T PCS Receiver

The PCS Receiver consists of several sub functional blocks that convert the incoming quartet of quinary symbols (PAM-5) data from the PMA Receiver A, B, C, and D to 8-bit receive data (RXD[7:0]), data valid (RX\_DV), and receive error (RX\_ER) signals on the GMII. The block diagram of the 1000BASE-T Functional Block in section "Block Diagram" on page 2 provides an overview of the

## 4.0 Functional Description (Continued)

1000BASE-T transceiver and shows the functionality of the PCS receiver.

The major sub functional blocks of the PCS Receiver include:

- Delay Skew Compensation
- Delay Skew Control
- Forward Error Correction (FEC)
- Descrambler Subsystem
- Receive State Machine
- ADC/DAC/Timing Subsystem

The requirements for the PCS receive functionality are defined in the IEEE 802.3ab specification in section 40.3.1.4 "PCS Receive function".

### 4.4.1 Delay Skew Compensation

This is a mechanism used to align the received data from the four PMA receivers and to determine the correct spacial ordering of the four incoming twisted pairs, i.e., which twisted pair carries  $A_n$ , which one carries  $B_n$ , etc. The de-skewed and ordered symbols are then presented to the Forward Error Correction (FEC) Decoder. The differential time or time delay skew is due to the differences in length of each of the four pairs of twisted wire in the CAT-5 cable, manufacturing variation of the insulation of the wire pairs, and in some cases, differences in insulation materials used in the wire pairs. Correct symbol order to the FEC is required, since the receiver does not have prior knowledge of the order of the incoming twisted pairs within the CAT-5 cable.

### 4.4.2 Delay Skew Control

This sub block controls the delay skew compensation function by providing the necessary controls to allow for compensation in two dimensions. The two dimensions are referring to time and position. The time factor is the delay skew between the four incoming data streams from the PMA RX A, B, C, and D. This delay skew originates back at the input to the ADC/DAC/TIMING subsystem. Since the receiver initially does not know the ordering of the twisted pairs, correct ordering must be determined automatically by the receiver during start-up. Delay skew compensation and twisted pair ordering is part of the training function performed during start-up mode of operation.

### 4.4.3 Forward Error Correction (FEC) Decoder

The FEC Decoder decodes the quartet of quinary (PAM-5) symbols and generates the corresponding  $Sd_n$  binary words. The FEC decoder uses a standard 8 state Trellis code operation. Initially,  $Sd_n[3:0]$  may not have the proper bit ordering, however, correct ordering is established by the reordering algorithm at start-up.

### 4.4.4 Descrambler Subsystem

The descrambler block performs the reverse scrambling function that was implemented in the transmit section. This sub block works in conjunction with the delay skew control. It provides the receiver generated  $Sd_n[3:0]$  bits for comparison in the delay skew control function.

### 4.4.5 Receive State Machine

The state machine operation is defined in IEEE 802.3ab section 40.3.1.4. In summary, it provides the necessary receive control signals of RX\_DV and RX\_ER to the GMII. In specific conditions defined in the IEEE 802.3ab specification, it generates RXD[7:0] data.

### 4.4.6 ADC/DAC/Timing Subsystem

The 1000BASE-T receive section consists of 4 channels, each receiving IEEE 802.3ab compliant PAM-5 coded data including Partial Response (PR) shaping at 125 MBaud over a maximum of a 100 m of CAT-5 cable. The 4 pairs of receive input pins are AC coupled through the magnetics to the CAT-5 cable. Each receive pin pair is differentially terminated into an external 100W resistor to match the cable impedance. Each receive channel consists of a high precision Analog to Digital data converter (ADC) which quantizes the incoming data into a digital word at the rate of 125 Mb/s. The ADC is sampled with a clock of 125 MHz which has been recovered from the incoming data stream.

The 1000BASE-T transmit section consists of 4 channels, each transmitting IEEE 802.3ab compliant 17-level PAM-5 data at 125 M symbols/second. The 4 pairs of transmit output pins are AC coupled through the magnetics to the CAT-5 cable. Each transmit pin pair is differentially terminated into an external 100W resistor to match the cable impedance. Each transmit channel consists of a Digital to Analog data converter (DAC) and line driver capable of producing 17 discrete levels corresponding to the PR shaping of a PAM-5 coded data stream. Each DAC is clocked with the internal 125 MHz clock in the MASTER mode, and the recovered receive clock in the SLAVE mode operation.

The DP83865 incorporates a sophisticated Clock Generation Module (CGM) which supports 10/100/1000 modes of operation with an external 25 MHz clock reference ( $\pm 50$  ppm). The Clock Generation module internally generates multiple phases of clocks at various frequencies to support high precision and low jitter Clock Recovery Modules (CRM) for robust data recovery, and to support accurate low jitter transmission of data symbols in the MASTER and SLAVE mode operations.

## 4.5 Gigabit MII (GMII)

The Gigabit Media Independent Interface (GMII) is intended for use between Ethernet PHYs and Station Management (STA) entities and is selected by either hardware or software configuration. The purpose of GMII is to make various physical media transparent to the MAC layer.

The GMII Interface accepts either GMII or MII data, control and status signals and routes them either to the 1000BASE-T, 100BASE-TX, or 10BASE-T modules, respectively.

## 4.0 Functional Description (Continued)

The mapping of the MAC interface is illustrated below in Table 51.

**Table 51. GMII/RGMII/MII Mapping**

GMII	RGMII	MII
RXD[3:0]	RX[3:0]	RXD[3:0]
RXD[4:7]		
RX_DV	RCK	RX_DV
RX_ER	RXDV_ER	RX_ER
RX_CLK		RX_CLK
	RGMII_SEL1	TX_CLK
TXD[3:0]	TX[3:0]	TXD[3:0]
TXD[4:7]		
TX_EN	TXEN_ER	TX_EN
TX_ER		TX_ER
GTX_CLK	TCK	
COL		COL
CRS	RGMII_SEL0	CRS

The GMII interface has the following characteristics:

- Supports 10/100/1000 Mb/s operation
- Data and delimiters are synchronous to clock references
- Provides independent 8-bit wide transmit and receive data paths
- Provides a simple management interface
- Uses signal levels that are compatible with common CMOS digital ASIC processes and some bipolar processes
- Provides for Full Duplex operation

The GMII interface is defined in the IEEE 802.3z document Clause 35. In each direction of data transfer, there are Data (an eight-bit bundle), Delimiter, Error, and Clock signals. GMII signals are defined such that an implementation may multiplex most GMII signals with the similar PCS service interface defined in IEEE 802.3u Clause 22.

Two media status signals are provided. One indicates the presence of carrier (CRS), and the other indicates the occurrence of a collision (COL). The GMII uses the MII management interface composed of two signals (MDC, MDIO) which provide access to management parameters and services as specified in IEEE 802.3u Clause 22.

The MII signal names have been retained and the functions of most signals are the same, but additional valid combinations of signals have been defined for 1000 Mb/s operation.

### 4.6 Reduced GMII (RGMII)

The Reduced Gigabit Media Independent Interface (RGMII) is designed to reduce the number of pins required to interconnect the MAC and PHY (Figure 5). To accomplish this goal, the data paths and all associated control signals are reduced and are multiplexed. Both rising and trailing edges of the clock are used. For Gigabit operation the clock is 125 MHz, and for 10 and 100 Mbps operation the clock frequencies are 2.5 MHz and 25 MHz, respectively. Please refer to the *RGMII Specification version 1.3* for detailed descriptions.

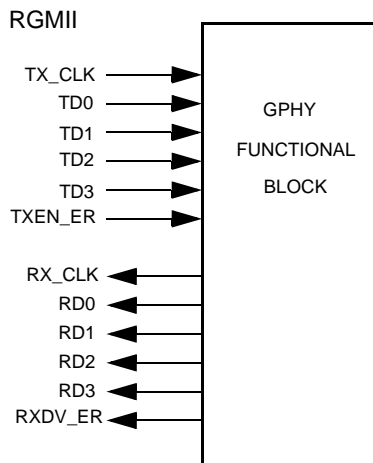

**Figure 5. RGMII Signals**

#### 4.6.1 1000 Mbps Mode Operation

All RGMII signals are positive logic. The 8-bit data is multiplexed by taking advantage of both clock edges. The lower 4 bits are latched on the positive clock edge and the upper 4 bits are latched on trailing clock edge. The control signals are multiplexed into a single clock cycle using the same technique.

To reduce power consumption of RGMII interface, TXEN\_ER and RXDV\_ER are encoded in a manner that minimize transitions during normal network operation. This is done by following encoding method. Note that the value of GMII\_TX\_ER and GMII\_TX\_EN are valid at the rising edge of the clock. In RGMII mode, GMII\_TX\_ER is resented on TXEN\_ER at the falling edge of the TCK clock. RXDV\_ER coding is implemented the same fashion.

$$TXEN\_ER \leq GMII\_TX\_ER \text{ (XOR) } GMII\_TX\_EN$$

$$RXDV\_ER \leq GMII\_RX\_ER \text{ (XOR) } GMII\_RX\_DV$$

When receiving a valid frame with no error, "RXDV\_ER = True" is generated as a logic high on the rising edge of RCK and "RXDV\_ER = False" is generated as a logic high at the falling edge of RCK. When no frame is being received, "RXDV\_ER = False" is generated as a logic low on the rising edge of RCK and "RXDV\_ER = False" is generated as a logic low on the falling edge of RCK.

When receiving a valid frame with error, "RXDV\_ER = True" is generated as logic high on the rising edge of RX\_CLK and "RXERR = True" is generated as a logic low on the falling edge of RCK.

TXEN\_ER is treated in a similar manner. During normal frame transmission, the signal stays at a logic high for both edges of TCK and during the period between frames where no error is indicated, the signal stays low for both edges.

#### 4.6.2 1000 Mbps Mode Timing

At the time of the publication of RGMII standard version 1.3, there are two different implementations of RGMII, HP and 3COM. The difference is in setup and hold timing. The DP83865 implemented the HP timing. The following is an explanation of the RGMII interface of the DP83865.

## 4.0 Functional Description (Continued)

### 1000 Mbps Mode Transmit Path Timing

In the transmit path, the TX signals are the output of the MAC and input of the PHY. The MAC output has a data to clock skew of -500 ps to +500 ps in both HP and 3COM mode. The PHY input, on the receiver side, requires data to clock input skew between 1.0 ns to 2.6 ns. To meet the minimum data skew of 1.0 ns at the PHY input while the MAC output skew is at -500 ps (i.e., the worst case), the clock signal (RGMII\_TCK) needs to be delayed by minimum of 1.5 ns. To meet the maximum data skew of 2.6 ns at the PHY input while MAC output skew is at +500 ps, the maximum clock delay (RGMII\_TCK) needs to be within 2.1 ns.

The 3COM mode clock delay is implemented internal in the DP83865DVH. The HP or 3COM mode can be selected at register 0x12.13:12.

### 1000 Mbps Mode Receive Path Timing

In the data receive path, the RX signals are the output of the PHY and input of the MAC. The PHY output has a data to clock skew of -500 ps to +500 ps (i.e., the HP mode).

If the MAC input, on the receiver side, is operating in 3COM mode that requires minimum of 1.0 ns setup time, the clock signal (RGMII\_RX\_CLK) needs to be delayed with minimum of 1.5 ns if the PHY output has a data to clock skew of -500 ps. The 3COM mode requires the MAC input has a minimum hold time of 0.8 ns. Meeting the 3COM minimum input hold time, the maximum clock signal delay while PHY output skew is at +500 ps would be 2.3 ns.

The 3COM mode clock delay is implemented internal in the DP83865DVH. The HP or 3COM mode can be selected at register 0x12.13:12.

### 4.6.3 10/100 Mbps Mode

When RGMII interface is working in the 100 Mbps mode, the Ethernet Media Independent Interface (MII) is implemented by reducing the clock rate to 25 MHz. For 10 Mbps operation, the clock is further reduced to 2.5 MHz. In the RGMII 10/100 mode, the transmit clock RGMII\_TX\_CLK is generated by the MAC and the receive clock RGMII\_RX\_CLK is generated by the PHY. During the packet receiving operation, the RGMII\_RX\_CLK may be stretched on either the positive or negative pulse to accommodate the transition from the free running clock to a data-synchronous clock domain. When the speed of the PHY changes, a similar stretching of the positive or negative pulses is allowed. No glitch is allowed on the clock signals during clock speed transitions.

This interface will operate at 10 and 100 Mbps speeds the same way it does at 1000 Mbps mode with the exception that the data may be duplicated on the falling edge of the appropriate clock.

The MAC will hold RGMII\_TX\_CLK low until it has ensured that it is operating at the same speed as the PHY.

### 4.7 10BASE-T and 100BASE-TX Transmitter

The 10BASE-T and 100BASE-TX transmitter consists of several functional blocks which convert synchronous 4-bit nibble data, as provided by the MII, to a 10 Mb/s MLT signal for 10BASE-T operation or scrambled MLT-3 125 Mb/s

serial data stream for 100BASE-TX operation. Since the 10BASE-T and 100BASE-TX transmitters are integrated with the 1000BASE-T, the differential output pins, TD+ /- are routed to channel A of the AC coupling magnetics.

The block diagram in Figure 6 provides an overview of each functional block within the 10BASE-T and 100BASE-TX transmit section. The Transmitter section consists of the following functional blocks:

#### 10BASE-T:

- NRZ to Manchester Encoder
- Link Pulse Generator
- Transmit Driver
- Jabber Detect

#### 100BASE-TX:

- Code-group Encoder and Injection block
- Parallel-to-Serial block
- Scrambler block
- NRZ to NRZI encoder block
- Binary to MLT-3 converter / DAC / Line Driver

In 10BASE-T mode the transmitter meets the IEEE 802.3 specification Clause 14.

The DP83865 implements the 100BASE-X transmit state machine diagram as specified in the IEEE 802.3u Standard, Clause 24.

#### 4.7.1 10BASE-T Manchester Encoder

The encoder begins operation when the Transmit Enable input (TXE) goes high. The encoder converts the clock and NRZ data to Manchester data for the transceiver. For the duration of TXE remaining high, the Transmit Data (TXD) is encoded for the transmit differential driver. TXD must be valid on the rising edge of Transmit Clock (TXC). Transmission ends when TXE goes low. The last transition is always positive; it occurs at the center of the bit cell if the last bit is a one, or at the end of the bit cell if the last bit is a zero.

#### 4.7.2 Link Pulse Generator

The link generator is a timer circuit that generates a normal link pulse (NLP) as defined by the 10 Base-T specification in 10BASE-T mode. The pulse which is 100ns wide is transmitted on the transmit output, every 16ms, in the absence of transmit data. The pulse is used to check the integrity of the connection to the remote MAU.

#### 4.7.3 Transmit Driver

The 10 Mb/s transmit driver in the DP83865 shares the 100/1000 Mb/s common driver.

#### 4.7.4 Jabber Detect

The Jabber Detect function disables the transmitter if it attempts to transmit a much longer than legal sized packet. The jabber timer monitors the transmitter and disables the transmission if the transmitter is active for greater than 20-30ms. The transmitter is then disabled for the entire time that the ENDEC module's internal transmit is asserted. The transmitter signal has to be deasserted for approximately 400-600ms (the unjab time) before the Jabber re-enables the transmit outputs.

Jabber status can be read from BMSR 0x01.1. For 100 Mb/s and 1000 Mb/s operations, Jabber Detect function is not incorporated so that BMSR 0x01.1 always returns "0".

## 4.0 Functional Description (Continued)

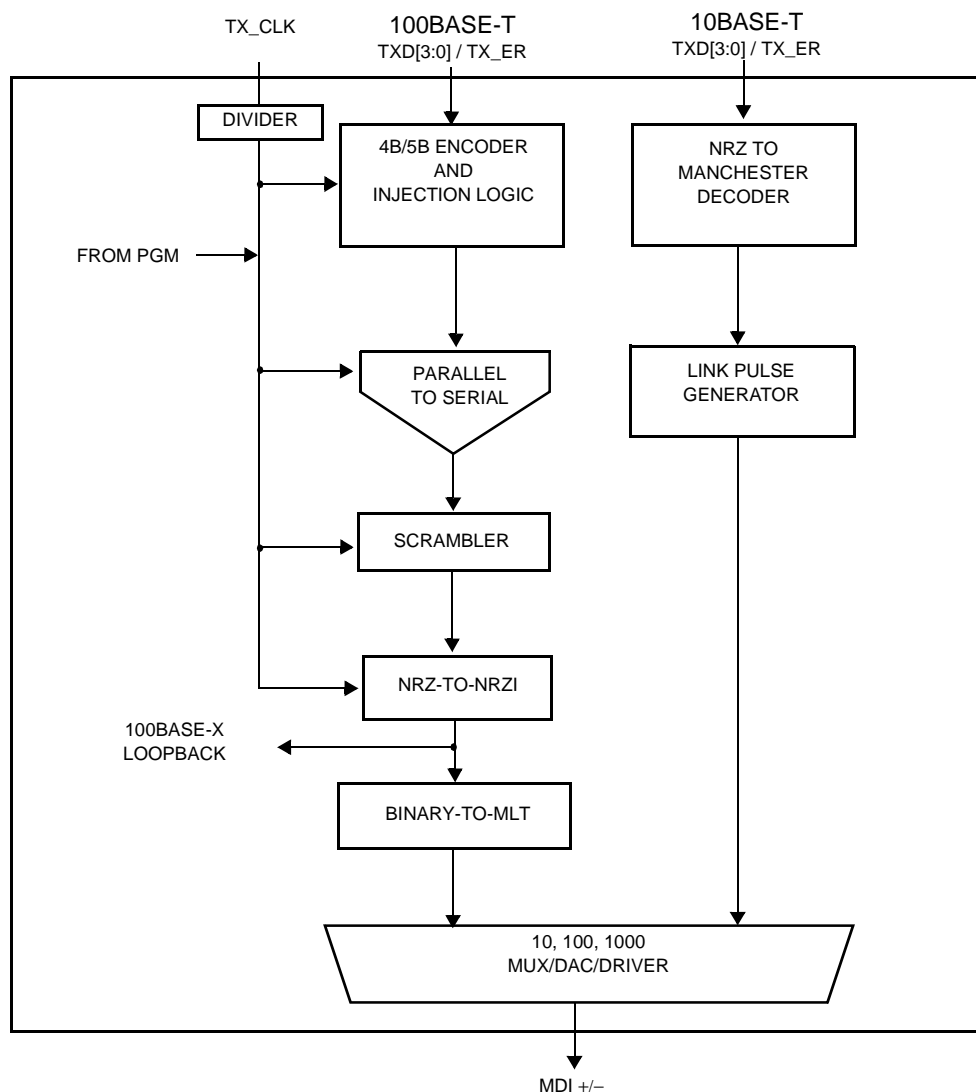

Figure 6. 10BASE-T/100BASE-TX Transmit Block Diagram

### 4.7.5 100BASE-T Code-group Encoding and Injection

The code-group encoder converts 4-bit (4B) nibble data generated by the MAC into 5-bit (5B) code-groups for transmission. This conversion is required to allow control data to be combined with packet data code-groups. Refer to Table 52 for 4B to 5B code-group mapping details.

The code-group encoder substitutes the first 8-bits of the MAC preamble with a /J/K/ code-group pair (11000 10001) upon transmission. The code-group encoder continues to replace subsequent 4B preamble and data nibbles with corresponding 5B code-groups. At the end of the transmit packet, upon the deassertion of Transmit Enable signal from the MAC, the code-group encoder injects the /T/R/ code-group pair (01101 00111) indicating the end of frame.

After the /T/R/ code-group pair, the code-group encoder continuously injects IDLEs into the transmit data stream until the next transmit packet is detected (reassertion of Transmit Enable).

### 4.7.6 Parallel-to-Serial Converter

The 5-bit (5B) code-groups are then converted to a serial data stream at 125 MHz.

### 4.7.7 Scrambler

The scrambler is required to control the radiated emissions at the media connector and on the twisted pair cable (for 100BASE-TX applications). By scrambling the data, the total energy launched onto the cable is randomly distributed over a wide frequency range. Without the scrambler, energy levels at the PMD and on the cable could peak beyond FCC limitations such as frequencies related to repeating 5B sequences (e.g., continuous transmission of IDLEs).

The scrambler is configured as a closed loop linear feedback shift register (LFSR) with an 11-bit polynomial. The output of the closed loop LFSR is X-ORed with the serial NRZ data from the serializer block. The result is a scrambled data stream with sufficient randomization to decrease radiated emissions at certain frequencies by as much as 20



## 4.0 Functional Description (Continued)

dB. The DP83865 uses the PHYADDR[4:0] value to set a unique seed value for the scramblers. The resulting energy generated by each channel is out of phase with respect to each channel, thus reducing the overall electro-magnetic radiation.

### 4.7.8 NRZ to NRZI Encoder

After the transmit data stream has been serialized and scrambled, the data is NRZI encoded to comply with the TP-PMD standard for 100BASE-TX transmission over Category-5 unshielded twisted pair cable. There is no ability to bypass this block within the DP83865.

**Table 52. 4B5B Code-Group Encoding/Decoding**

Name	PCS 5B Code-group	MII 4B Nibble Code
<b>DATA CODES</b>		
0	11110	0000
1	01001	0001
2	10100	0010
3	10101	0011
4	01010	0100
5	01011	0101
6	01110	0110
7	01111	0111
8	10010	1000
9	10011	1001
A	10110	1010
B	10111	1011
C	11010	1100
D	11011	1101
E	11100	1110
F	11101	1111
<b>IDLE AND CONTROL CODES</b>		
H	00100	HALT code-group - Error code
I	11111	Inter-Packet IDLE - 0000 (Note 1)
J	11000	First Start of Packet - 0101 (Note 1)
K	10001	Second Start of Packet - 0101 (Note 1)
T	01101	First End of Packet - 0000 (Note 1)
R	00111	Second End of Packet - 0000 (Note 1)
<b>INVALID CODES</b>		
V	00000	0110 or 0101 (Note 2)
V	00001	0110 or 0101 (Note 2)
V	00010	0110 or 0101 (Note 2)
V	00011	0110 or 0101 (Note 2)
V	00101	0110 or 0101 (Note 2)
V	00110	0110 or 0101 (Note 2)
V	01000	0110 or 0101 (Note 2)
V	01100	0110 or 0101 (Note 2)
V	10000	0110 or 0101 (Note 2)
V	11001	0110 or 0101 (Note 2)

**Note 1:** Control code-groups I, J, K, T and R in data fields will be mapped as invalid codes, together with RX\_ER asserted.

**Note 2:** Normally, invalid codes (V) are mapped to 6h on RXD[3:0] with RX\_ER asserted.

## 4.0 Functional Description (Continued)

### 4.7.9 MLT-3 Converter / DAC / Line Driver

The Binary to MLT-3 conversion is accomplished by converting the serial NRZI data stream output from the NRZI encoder into two binary data streams with alternately

phased logic one events. These two binary streams are then passed to a 10/100/1000 DAC and line driver which converts the pulses to suitable analog line voltages. Refer to Figure 8.

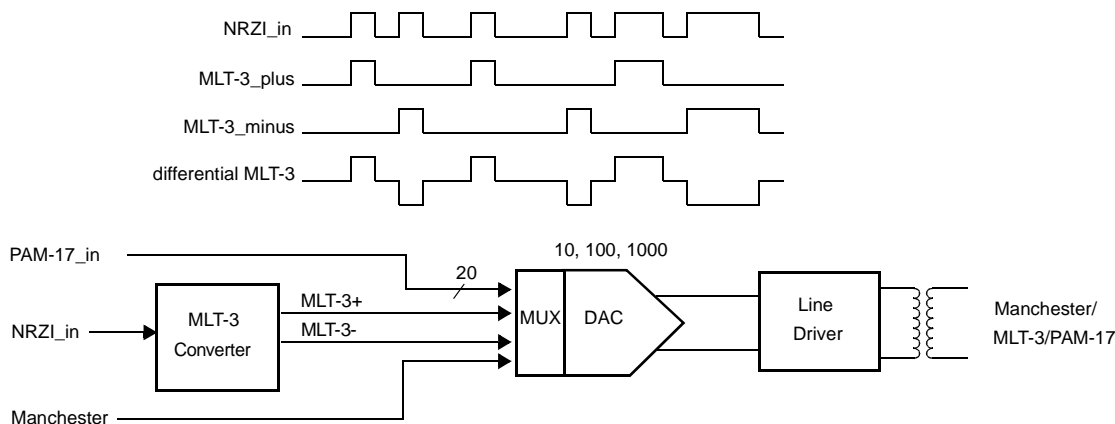

Figure 7. NRZI to MLT-3 conversion

The 100BASE-TX MLT-3 signal sourced by the MDI+/- line driver output pins is slew rate controlled. This should be considered when selecting AC coupling magnetics to ensure TP-PMD Standard compliant transition times ( $3 \text{ ns} < t_r < 5 \text{ ns}$ ).

The 100BASE-TX transmit TP-PMD function within the DP83865 outputs only MLT-3 encoded data. Binary data outputs is not available from the MDI+/- in the 100 Mb/s mode.

#### 4.7.10 TX\_ER

Assertion of the TX\_ER input while the TX\_EN is also asserted will cause the DP83865 to substitute HALT code-groups for the 5B data present at TXD[3:0]. However, the Start-of-Stream Delimiter (SSD) /J/K/ and End-of-Stream Delimiter (ESD) /T/R/ will not be substituted with HALT code-groups. As a result, the assertion of TX\_ER while TX\_EN is asserted will result in a frame properly encapsulated with the /J/K/ and /T/R/ delimiters which contains HALT code-groups in place of the data code-groups.

### 4.8 10BASE-T and 100BASE-TX Receiver

The 10BASE-T receiver converts Manchester coding to 4-bit nibble data to the MII. The 100BASE-TX receiver consists of several sub functional blocks which convert the scrambled MLT-3 125 Mb/s serial data stream to synchronous 4-bit nibble data that is provided to the MII. The 10/100 Mb/s TP-PMD is integrated with the 1000 Mb/s. The 10/100 differential input data MDI+/- is routed from channel B of the isolation magnetics.

See Figure 8 for a block diagram of the 10BASE-T AND 100BASE-TX receive function. It provides an overview of each functional block within the 10/100 receive section.

The 10BASE-T Receive section consists of the following functional blocks:

- Receiver
- Clock and Data Recovery

- Manchester Decoder
- Link Detect

The 100BASE-T Receive section consists of the following functional blocks:

- ADC Block
- Signal Detect
- BLW/EQ/AAC Correction
- Clock Recovery Module
- MLT-3 to NRZ Decoder
- Descrambler
- Serial to Parallel
- 5B/4B Decoder
- Code Group Alignment
- Link Integrity Monitor

Other topics discussed are:

- Bad SSD Detection
- Carrier Sense
- Collision Detect

#### 4.8.1 10BASE-T Receiver

The receiver includes differential buffer, offset and gain compensation. The receiver provides the signal conditioning to the Clock and Data Recovery block.

#### 4.8.2 Clock and Data Recovery

The Clock and Data Recovery block separates the Manchester encoded data stream into internal clock signals and data. Once the input exceeds the squelch requirements, Carrier Sense (CRS) is asserted off the first edge presented to the Manchester decoder.

#### 4.8.3 Manchester Decoder

Once the Manchester decoder locks onto the incoming data stream, it converts Manchester data to NRZ data. The decoder detects the end of a frame when no more mid-bit transitions are detected. Within one and a half bit times

## 4.0 Functional Description (Continued)

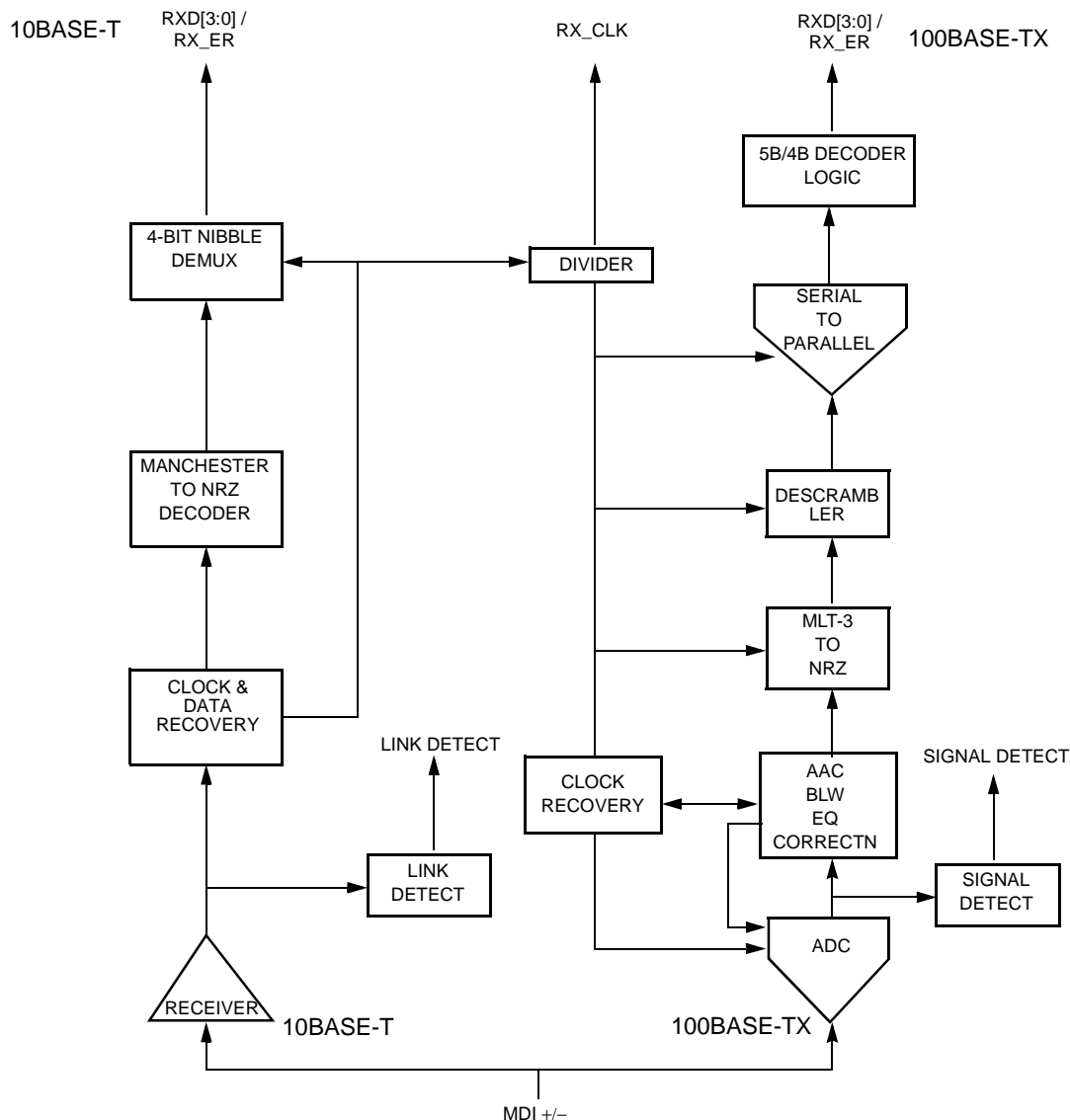

Figure 8. 10BASE-T/100BASE-T Receive Block Diagram

after the last bit, carrier sense is de-asserted. Receive clock stays active for at least five more bit times after CRS goes low, to guarantee the receive timings of the controller.

The aligned NRZ data is then parallelized and aligned to 4-bit nibbles that is presented to the MII.

### 4.8.4 Link Detector

In 10 BASE-T mode, the link detection circuit checks for valid NLP pulses transmitted by the remote link partner. If valid link pulses are not received the link detector will disable the twisted pair transmitter, receiver and collision detection functions.

### 4.8.5 100 BASE-TX ADC Block

The DP83865 requires no external attenuation circuitry at its receive inputs, MDI+/- . It accepts TP-PMD compliant waveforms directly from a 1:1 transformer. The analog MLT-3 signal (with noise and system impairments) is received and converted to the digital domain via an Analog

to Digital Converter (ADC) to allow for Digital Signal Processing (DSP) to take place on the received signal.

### 4.8.6 BLW / EQ / AAC Correction

The digital data from the ADC block flows into the DSP Block (BLW/EQ/AAC Correction) for processing. The DSP block applies proprietary processing algorithms to the received signal and are all part of an integrated DSP receiver. The primary DSP functions applied are:

- BLW is defined as the change in the average DC content, over time, of an AC coupled digital transmission over a given transmission medium. (i.e. copper wire). BLW results from the interaction between the low frequency components of a transmitted bit stream and the frequency response of the AC coupling component(s) within the transmission system. If the low frequency content of the digital bit stream goes below the low frequency pole of the AC coupling transformer then the droop characteristics of the transformer will dominate resulting

## 4.0 Functional Description (Continued)

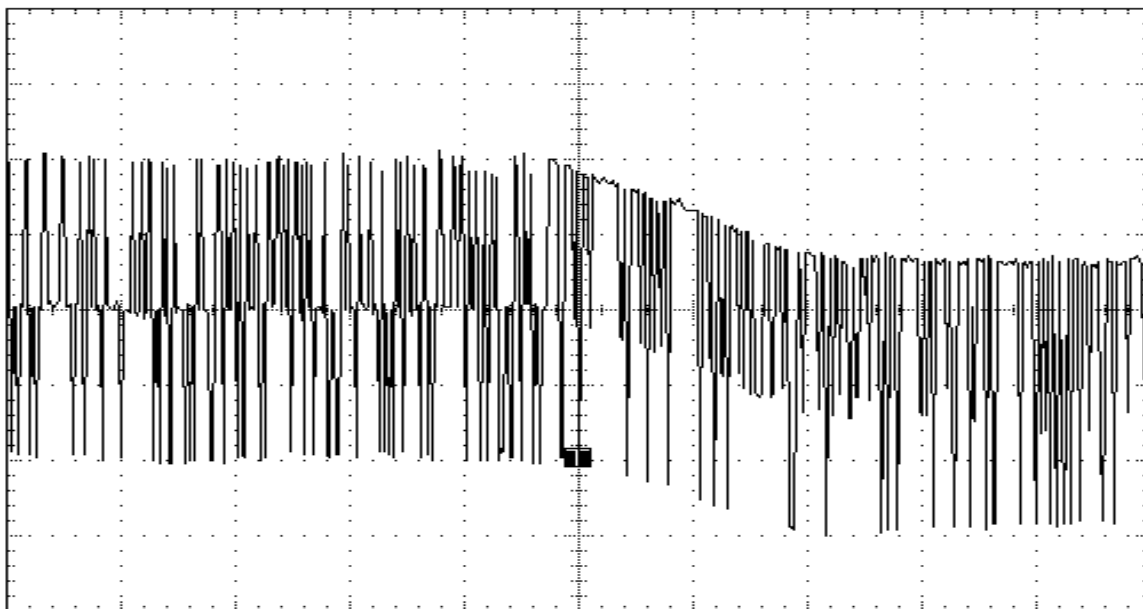

**Figure 9. 100BASE-TX BLW Event**

in potentially serious BLW. The digital oscilloscope plot provided in Figure 9 illustrates the severity of the BLW event that can theoretically be generated during 100BASE-TX packet transmission. This event consists of approximately 800 mV of DC offset for a period of 120 ms. Left uncompensated, events such as this can cause packet loss.

- In high-speed twisted pair signalling, the frequency content of the transmitted signal can vary greatly during normal operation based primarily on the randomness of the scrambled data stream and is thus susceptible to frequency dependent attenuation (see Figure 10). This variation in signal attenuation caused by frequency variations must be compensated to ensure the integrity of the transmission. In order to ensure quality transmission when using MLT-3 encoding, the compensation must be able to adapt to various cable lengths and cable types depending on the installed environment. The usage of long cable length requires significant compensation which will over-compensate for shorter and less attenuating lengths. Conversely, the usage of short or intermediate cable length requiring less compensation will cause serious under-compensation for longer length cables. Therefore, the compensation or equalization must be adaptive to ensure proper level of the received signal independent of the cable length.
- Automatic Attenuation Control (AAC) allows the DSP block to fit the resultant output signal to match the limit characteristic of its internal decision block to ensure error free sampling.

### 4.8.7 Signal Detect

In 100BASE-TX mode, the link is established by detecting the scrambled idles from the link partner.

In 100BASE-T mode, the signal detect function of the DP83865 meets the specifications mandated by the ANSI FDDI TP-PMD Standard as well as the IEEE 802.3

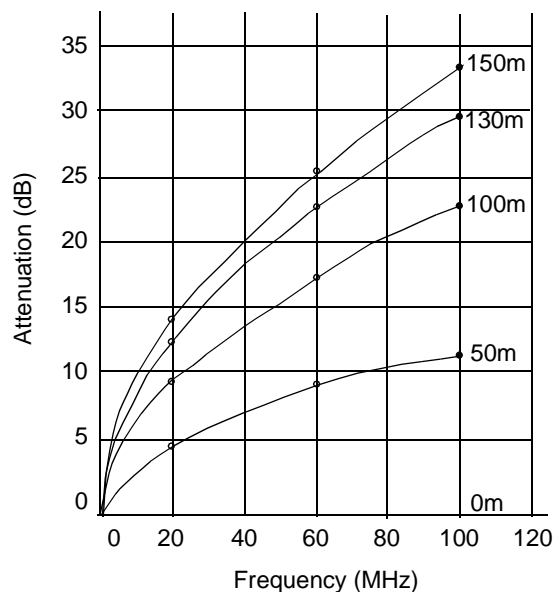

**Figure 10. EIA/TIA Attenuation vs. Frequency for 0, 50, 100, 130 & 150 meters of CAT 5 cable**

100BASE-TX Standard for both voltage thresholds and timing parameters.

Note that the reception of fast link pulses per IEEE 802.3u Auto-Negotiation by the 100BASE-X receiver will not cause the DP83865 to assert signal detect.

### 4.8.8 Clock Recovery Module

The Clock Recovery Module generates a phase corrected clocks for the 100BASE-T receiver.

## 4.0 Functional Description (Continued)

The CRM is implemented using an advanced digital Phase Locked Loop (PLL) architecture that replaces sensitive analog circuitry. Using digital PLL circuitry allows the DP83865 to be manufactured and specified to tighter tolerances.

### 4.8.9 MLT-3 to NRZ Decoder

The DP83865 decodes the MLT-3 information from the DSP block to binary NRZI form and finally to NRZ data.

### 4.8.10 Descrambler

A serial descrambler is used to de-scramble the received NRZ data. The descrambler has to generate an identical data scrambling sequence (N) in order to recover the original unscrambled data (UD) from the scrambled data (SD) as represented in the equations:

$$\begin{aligned}SD &= (UD \oplus N) \\UD &= (SD \oplus N)\end{aligned}$$

Synchronization of the descrambler to the original scrambling sequence (N) is achieved based on the knowledge that the incoming scrambled data stream consists of scrambled IDLE data. After the descrambler has recognized 12 consecutive IDLE code-groups, where an unscrambled IDLE code-group in 5B NRZ is equal to five consecutive ones (11111), it will synchronize to the receive data stream and generate unscrambled data in the form of unaligned 5B code-groups.

In order to maintain synchronization, the descrambler must continuously monitor the validity of the unscrambled data that it generates. To ensure this, a line state monitor and a hold timer are used to constantly monitor the synchronization status. Upon synchronization of the descrambler the hold timer starts a 722 ms countdown. Upon detection of sufficient IDLE code-groups (16 idle symbols) within the 722 ms period, the hold timer will reset and begin a new countdown. This monitoring operation will continue indefinitely given a properly operating network connection with good signal integrity. If the line state monitor does not recognize sufficient unscrambled IDLE code-groups within the 722 ms period, the entire descrambler will be forced out of the current state of synchronization and reset in order to re-acquire synchronization.

### 4.8.11 Serial to Parallel Converter

The 100BASE-X receiver includes a Serial to Parallel converter this operation also provides code-group alignment, and operates on unaligned serial data from the descrambler (or, if the descrambler is bypassed, directly from the MLT-3 to NRZ decoder) and converts it into 5B code-group data (5 bits). Code-group alignment occurs after the /J/K/ code-group pair is detected. Once the /J/K/ code-group pair (11000 10001) is detected, subsequent data is aligned on a fixed boundary.

### 4.8.12 5B/4B Decoder

The code-group decoder functions as a look up table that translates incoming 5B code-groups into 4B nibbles. The code-group decoder first detects the /J/K/ code-group pair preceded by IDLE code-groups and replaces the /J/K/ with MAC preamble. Specifically, the /J/K/ 10-bit code-group pair is replaced by the nibble pair (0101 0101). All subsequent 5B code-groups are converted to the corresponding 4B nibbles for the duration of the entire packet. This con-

version ceases upon the detection of the /T/R/ code-group pair denoting the End of Stream Delimiter (ESD) or with the reception of a minimum of two IDLE code-groups.

### 4.8.13 100BASE-X Link Integrity Monitor

The 100BASE-X Link monitor ensures that a valid and stable link is established before enabling both the Transmit and Receive PCS layer. Signal Detect must be valid for at least 500 ms to allow the link monitor to enter the "Link Up" state, and enable transmit and receive functions.

### 4.8.14 Bad SSD Detection

A Bad Start of Stream Delimiter (Bad SSD) is any transition from consecutive idle code-groups to non-idle code-groups which is not prefixed by the code-group pair /J/K/.

If this condition is detected, the DP83865 will assert RX\_ER and present RXD[3:0] = 1110 to the MII for the cycles that correspond to received 5B code-groups until at least two IDLE code groups are detected.

Once at least two IDLE code groups are detected, RX\_ER and CRS become de-asserted.

### 4.8.15 Carrier Sense

Carrier Sense (CRS) may be asserted due to receive activity once valid data is detected via the Smart squelch function.

For 10/100 Mb/s Half Duplex operation, CRS is asserted during either packet transmission or reception.

For 10/100 Mb/s Full Duplex operation, CRS is asserted only due to receive activity.

CRS is deasserted following an end of packet.

### 4.8.16 Collision Detect and Heartbeat

A collision is detected on the twisted pair cable when the receive and transmit channels are active simultaneously while in Half Duplex mode.

Also after each transmission, the 10 Mb/s block will generate a Heartbeat signal by applying a 1 us pulse on the COL lines which go into the MAC. This signal is called the Signal Quality Error (SQE) and its function as defined by IEEE 802.3 is to assure the continued functionality of the collision circuitry.

## 4.9 Media Independent Interface (MII)

The DP83865 incorporates the Media Independent Interface (MII) as specified in Clause 22 of the IEEE 802.3u standard. This interface may be used to connect PHY devices to a MAC in 10/100 Mb/s mode. This section describes both the serial MII management interface as well as the nibble wide MII data interface.

The serial management interface of the MII allows for the configuration and control of multiple PHY devices, gathering of status, error information, and the determination of the type and capabilities of the attached PHY(s).

The nibble wide MII data interface consists of a receive bus and a transmit bus each with control signals to facilitate data transfer between the PHY and the upper layer (MAC).

This section covers the following subjects:

- Serial Management Register Access
- Serial Management Access Protocol

## 4.0 Functional Description (Continued)

- Serial Management Preamble Suppression
- PHY Address Sensing
- MII Data Interface
- MII Isolate Mode
- Status LED's

### 4.9.1 Serial Management Register Access

The serial management MII specification defines a set of thirty-two 16-bit status and control registers that are accessible through the management interface pins MDC and MDIO for 10/100/1000 Mb/s operation. The DP83865 implements all the required MII registers as well as several optional registers. These registers are fully described in section "2.3 Register Description". Note that by default, the PHY base address is 01H that is the Port 1 address. If multiple PHY's are used, MDC and MDIO for each DP83865 may be connected together to simplify the interface. The base address for each single PHY should be different.

### 4.9.2 Serial Management Access Protocol

The serial control interface consists of two pins, Management Data Clock (MDC) and Management Data Input/Output (MDIO). MDC has a maximum clock rate of 2.5 MHz and no minimum rate. The MDIO line is bi-directional and is capable of addressing up to thirty-two PHY addresses. The MDIO frame format is shown below in Table 53.

The MDIO pin requires a pull-up resistor (2 kΩ). During IDLE and Turnaround, the MDIO signal is pulled high. In

order to initialize the MDIO interface, the station management entity sends a sequence of 32 contiguous logic ones on MDIO to provide the DP83865 with a sequence that can be used to establish synchronization. This preamble may be generated either by driving MDIO high for 32 consecutive MDC clock cycles, or by simply allowing the MDIO pull-up resistor to pull the MDIO pin high during which time 32 MDC clock cycles are provided. In addition 32 MDC clock cycles should be used to re-synchronize the device if an invalid start, op code, or turnaround bit is detected.

The DP83865 operation is pending until it receives the preamble sequence before responding to any other transaction. Once the DP83865 serial management port has been initialized no further preamble sequencing is required until after power-on, reset, invalid Start, invalid Opcode, or invalid turnaround bit occurs.

The Start code is indicated by a <01> pattern. This assures the MDIO line transitions from the default idle line state.

Turnaround is defined as an idle bit time inserted between the register address field and the data field. To avoid contention during a read transaction, no device shall actively drive the MDIO signal during the first bit of Turnaround. The addressed DP83865 drives the MDIO with a zero for the second bit of turnaround and follows this with the required data. Figure 11 shows the timing relationship between MDC and the MDIO as driven/received by the Station (STA) and the DP83865 (PHY) for a typical register read access.

Table 53. Typical MDIO Frame Format

MII Management Serial Protocol	<idle><start><op code><device addr><reg addr><turnaround><data><idle>
Read Operation	<idle><01><10><AAAAA><RRRRR><Z0><xxxx xxxx xxxx xxxx><idle>
Write Operation	<idle><01><01><AAAAA><RRRRR><10><xxxx xxxx xxxx xxxx><idle>

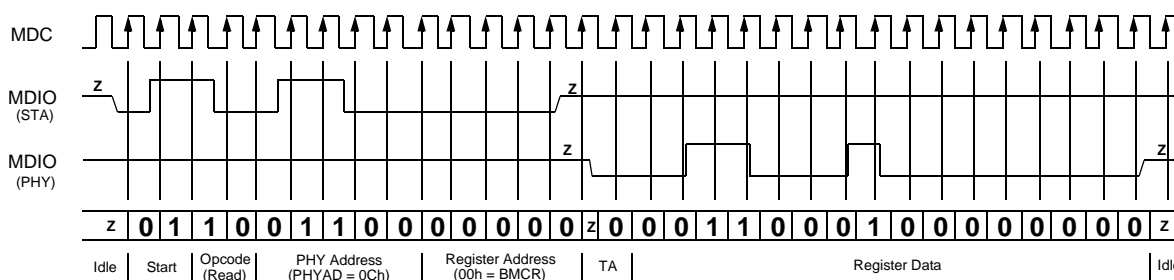

Figure 11. Typical MDC/MDIO Read Operation

For write transactions, the station management entity writes data to a PHY address thus eliminating the requirement for MDIO Turnaround. The Turnaround time is filled by the management entity by asserting <10>. Figure 12 shows the timing relationship for a typical MII register write access.

### 4.9.3 Serial Management Preamble Suppression

The DP83865 supports a Preamble Suppression mode as indicated by a one in bit 6 of the Basic Mode Status Register (BMSR 0x01). If the station management entity (i.e.,

MAC or other management controller) determines that all PHY's in the system support Preamble Suppression by returning a one in this bit, then the station management entity need not generate preamble for each management transaction. A *minimum of one idle bit between management transactions is required* as specified in IEEE 802.3u. After power-up, the DP83865 requires one idle bit prior to any management access.



## 5.0 Design Guide

The design guide in conjunction with the Reference Design Schematics/BOM is intended to provide information to assist in the design and layout of the DP83865 Gigabit Ethernet Transceiver. The design guide covers the following topics:

- Hardware Reset
- Clocks
- Power Supply Decoupling
- Sensitive Supply Pins
- PCB Layer Stacking
- Layout Notes on MAC Interface
- Twisted Pair Interface
- RJ-45 Connections
- Unused Pins / Reserved Pins
- LED/Strapping Configuration
- I/O Voltage Considerations
- Power-up Recommendations
- Component Selection

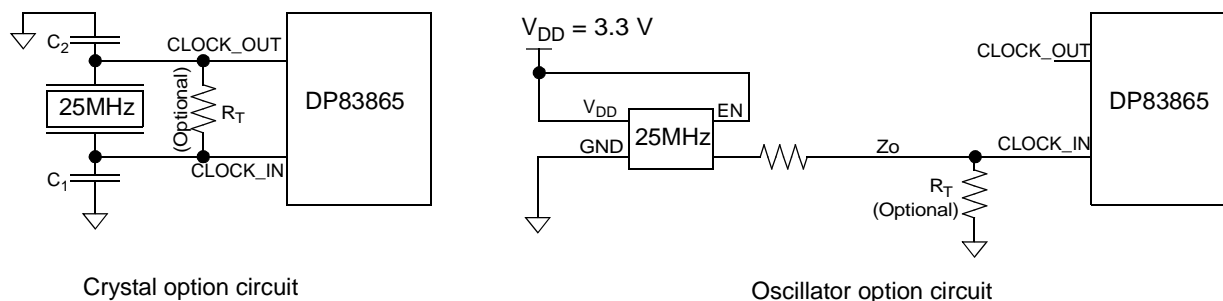

Figure 13. Clock Input Circuit

There are a number of ways to terminate clock traces when an oscillator is used. The commonly used types are series and parallel termination. Series termination consumes less power and it is the recommended termination. The value of the series termination resistor is chosen to match the trace characteristics impedance. For example, if the clock source has an output impedance of  $20\Omega$  and the clock trace has the characteristic impedance  $Z_0 = 50\Omega$  then  $R_s = 50 - 20 = 30\Omega$ . The series source termination  $R_s$  should be placed close to the output of the oscillator.

The parallel termination consumes more power than series termination, and yields faster rise and fall times. The value of the termination is equal to the trace characteristic impedance,  $R_T = Z_0$ . The parallel termination  $R_T$  should be placed close to the CLOCK\_IN pin to eliminate reflections.

In cases there are multiple PHY devices reside on the same board, it may be cost effective to use one oscillator with a high speed PLL clock distribution driver. Connecting multiple clock inputs in a daisy chained style should be avoided, especially when series termination is applied.

No termination is necessary if a crystal is used. The crystal should be placed as close as possible to the CLOCK pins. The capacitors C1 and C2 are used to adjust the load capacitance on these pins. (Figure 13.) The total load capacitance (C1, C2 and crystal) must be within a certain range for the DP83865 to function properly (see Table 55 for crystal requirements). The parallel resistor  $R_T$  is recom-

## 5.1 Hardware Reset

The active low  $\overline{\text{RESET}}$  pin 33 should be held low for a minimum of  $150\text{ ns}$  to allow hardware reset. For timing details see Section 6.2. There is no on-chip internal power-on reset and the DP83865 requires an external reset signal applied to the  $\overline{\text{RESET}}$  pin.

## 5.2 Clocks

The CLOCK\_IN pin is the 25 MHz clock input to the DP83865 used by the internal PLL. This input should come from a 25 MHz clock oscillator or a crystal. (Check Section 5.13.1 for component requirements.) When using a crystal, CLOCK\_OUT must be connected to the second terminal of the crystal. For usage with a oscillator the CLOCK\_OUT pin should be left floating.

The output of the clock signal requires termination consideration. The termination requirement depends on the trace length of the clock signal. No series or load termination is required for short traces less than 3 inches. For longer traces termination resistors are recommended.

mended by some crystal vendors. Refer to the vendor's crystal datasheet for details.

Adequate and proper decoupling is important to the clock oscillator performance. A multilayer ceramic chip capacitor should be placed as close to the oscillator's VDD pin as possible to supply the additional current during the transient switching.

EMI is another consideration when designing the clock circuitry. The EMI field strength is proportional to the current flow, frequency, and loop area. By applying series termination, the current flow is less than parallel termination and the edge speed is slower, making it desirable for EMI considerations. The loop area is defined as the trace length times the distance to the ground plane, i.e., the current return path. Keeping the clock trace as short as possible reduces the loop area that reduces EMI.

It is best to place the oscillator towards the center of the PCB rather than at the edge. The radiated magnetic field tends to be stronger when traces are running along the PCB edge. If the trace has to run along the edge of the board, make sure the trace to board edge distance is larger than the trace to ground plane distance. This makes the field around the trace more easily coupled to the ground than radiating off the edge. If the clock trace is placed on the surface layer, placing a parallel ground trace on each side of the clock trace localizes the EMI and also prevent crosstalk to adjacent traces. Burying the clock trace in



## 5.0 Design Guide (Continued)

between the ground and VDD plane also minimizes EMI radiation.

Any through-hole clock oscillator component should be mounted as flat and as close to the PCB as possible. Excessive leads should be trimmed. Provide a ground pad equal or larger than the oscillator foot print on the component side of the PCB. Tie this ground pad to the ground plane through multiple vias. This minimizes the distance to the ground plane and provide better coupling of the electromagnetic fields to the board.

### 5.3 Power Supply Decoupling

The capacitance between power and ground planes can provide appreciable power supply decoupling for high edge rate circuits. This "plane capacitor" has very low ESR and ESL so that the plane capacitance remains effective at the frequencies so high that chip capacitors become ineffective. It is strongly recommended that the PCB have one solid ground plane and at least one split power plane with 2.5V and 1.8V copper islands. Ideally the PCB should have solid planes for each of the supply voltages. The interplane capacitance between the supply and ground planes may be maximized by reducing the plane spacing. In addition, filling unused board areas on signal planes with copper and connecting them to the proper power plane will also increase the interplane capacitance.

The 2.5V and the 1.8V supply pins are paired with their corresponding ground pins. Every other paired supply pins need to be decoupled with Surface Mount Technology (SMT) capacitors. It's recommended that SMT capacitance alternates between 0.01  $\mu$ F and 0.1  $\mu$ F so that the resonance frequencies of the capacitors are "dispersed". The decoupling capacitors should be placed as close to the supply pin as possible. For optimal results, connect the decoupling capacitors directly to the supply pins where the capacitors are placed 0.010 inch to the power pins. For lowest ESL and best manufacturability, place the plane connecting via within 0.010 inch to the SMT capacitor pads (Figure 14).

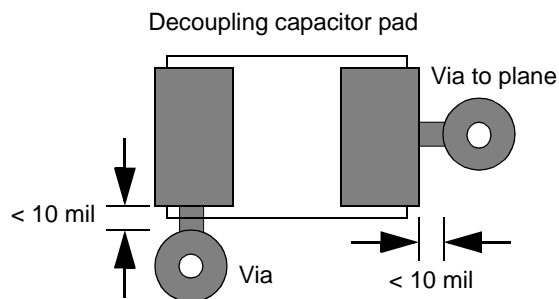

**Figure 14. Place via close to pad.**

Bulk capacitance supplies current and maintains the voltage level at frequencies above the rate that the power supply can respond to and below frequencies chip capacitors are effective. To supply lower speed transient current, a tantalum 10  $\mu$ F capacitor for each power plane and each port should also be placed near the DP83865.

Lowering the power supply plane and ground plane impedance will also reduce the power supply noise. 1 oz. copper is recommended for the power and ground planes. Avoid routing power or ground traces to the supply pins that could

introduce inductive coupling leading to ground bounce. Connect power and ground pins directly to the planes.

The power supply decoupling recommendations may be perceived conservative. However, for the early prototyping, please follow the guide lines and recommendations to assure first time success. To lower the manufacturing cost, the component count may be reduced by the designer after careful evaluation and extensive tests on EMI and bit-error-rate (BER) performance.

### 5.4 Sensitive Supply Pins

The Analog 1V8\_AVDD2 and 1V8\_AVDD3 supply are susceptible to noise and requires special filtering to attenuate high frequencies. A low pass filter for each of the supply pin is suggested (Figure 15).

A 1% 9.76 k $\Omega$  resistor is needed to connect to the BG\_REF pin. The connections to this resistor needs to be kept as short as possible (Figure 15).

Avoid placing noisy digital signal traces near these sensitive pins. It is recommended that the above mentioned components should be placed before other components.

The 1.8V supplies both the digital core and the analog. The analog power supply is sensitive to noise. To optimize the analog performance, it is best to locate the voltage regulator close to the analog supply pins. Avoid placing the digital core supply and GMAC in the analog return path. An example of voltage regulator placement is shown in Figure 16.

Ferrite beads could be used to isolate noisy VCC pins and preventing noise from coupling into sensitive VCC pins. This bead in conjunction with the bypass capacitors at the VCC pins form a low pass filter that prevents the high frequency noise from coupling into the quiet VCC. However, the use of ferrite beads may yield mixed results when the inductance resonates with the capacitance. To decrease the likelihood of resonance, a resistor in parallel with the ferrite bead may be used. The noise characteristics vary from design to design. Ferrite beads may not be effective in all cases. The decision is left to the board designer based on the evaluation of a specific case.

### 5.5 PCB Layer Stacking

To route traces for the DP83865 PQFP package, a minimum of four PCB layers is necessary. To meet performance requirements, a six layer board design is recommended. The following is the layer stacking recommendations for four and six-layer boards.

Four-layer board (typical application: NIC card):

1. Top layer - signal
2. GND
3. 3.3 Volt power plane
4. Bottom layer - signal, planes for 1.8 Volt and 2.5 Volt

Six-layer board:

1. Top layer - signal
2. 2.5 Volt power plane
3. GND
4. 1.8 Volt power plane
5. Power plane for IO\_VDD and/or 3.3 Volt
6. Bottom layer - signal

Note that signal traces crossing a plane split should be avoided (Figure 17). Signal crossing a plane split may cause unpredictable return path currents and would likely

5.0 Design Guide (Continued)

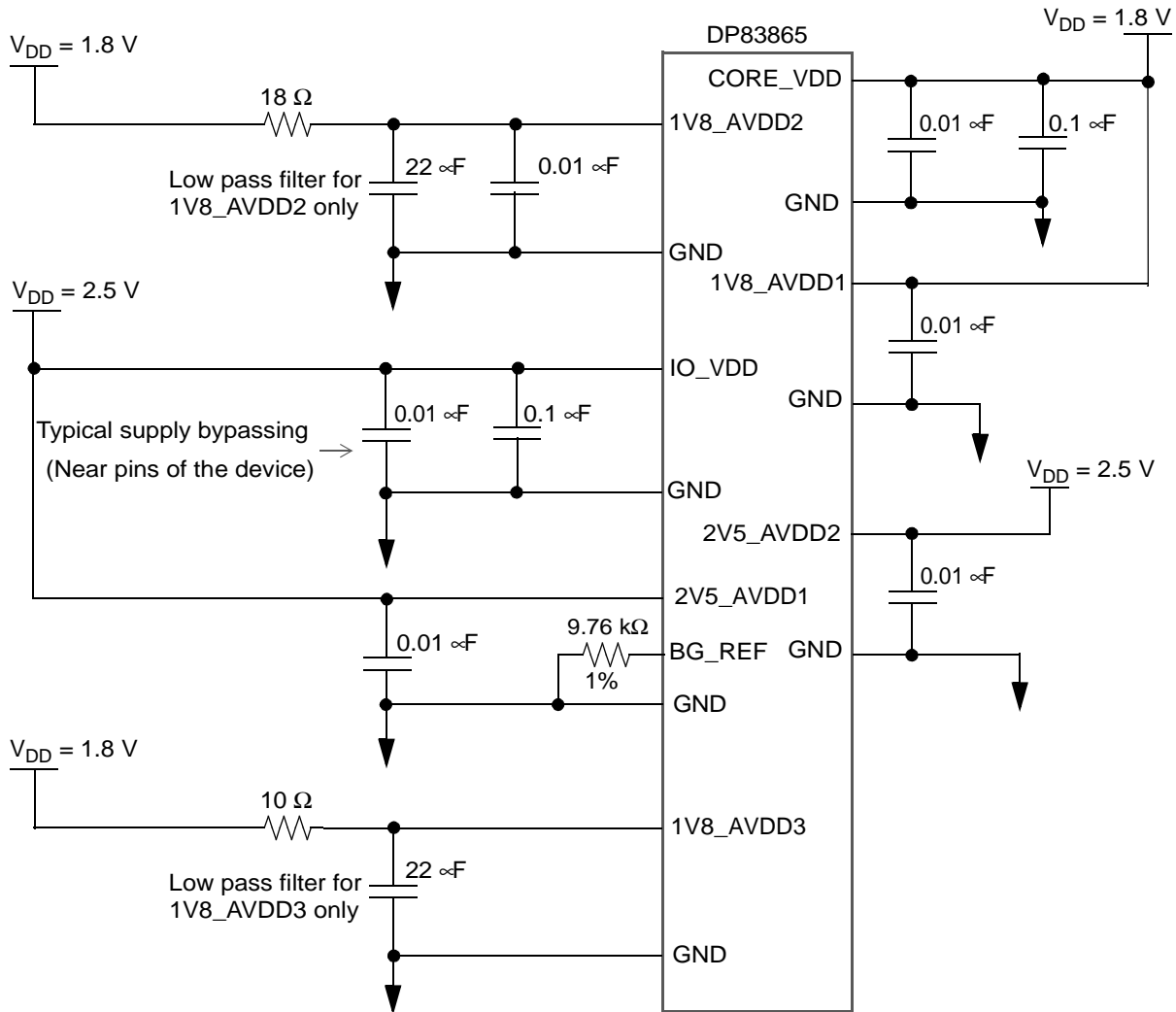

Figure 15. Power Supply Filtering

DP83865 and GMAC PCI NIC Card

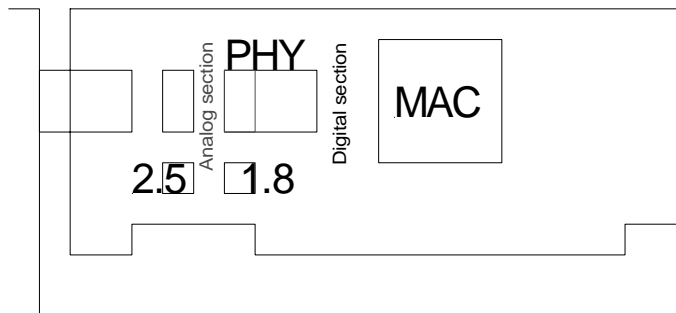

Figure 16. 1.8V voltage regulator placement.

to result in signal quality failure as well as creating EMI problems.

## 5.0 Design Guide (Continued)

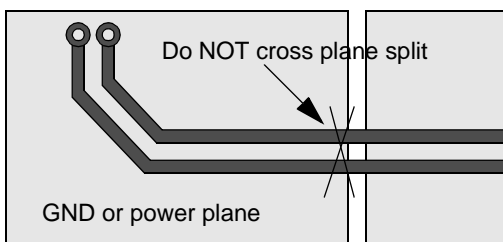

Figure 17. Signal crossing a plane split

### 5.6 Layout Notes on MAC Interface

#### Trace Impedance

All the signal traces of MII and GMII should be impedance controlled. The trace impedance reference to ground is 50 Ohms. Uncontrolled impedance runs and stubs should be kept to minimum.

#### 5.6.1 MII, GMII, and RGMII Interfaces

II and GMII are single ended signals. The output of these signals are capable of driving 35 pF under worst conditions. However, these outputs are not designed to drive multiple loads, connectors, backplanes, or cables.

#### Termination Requirement

The purpose of the series termination is to reduce reflections and to improve the signal quality. The board designer should evaluate the reflection and signal integrity to determine the need for the termination in each design. As a general rule, if the trace length is less than 1/6 of the equivalent length of the rise and fall times, the series termination is not needed. The following is an example of calculating the signal trace length.

The rise and fall times of GMII are in the order of 500 ps for RX\_CLK, and GTX\_CLK. Propagation Delay = 170 ps/inch on a FR4 board. Equivalent length of rise time = (1/6) Rise time (ps) / Delay (ps/inch) = (1/6) \* (500/ 170) = 0.5 inch. Thus, series termination is not needed for traces less than 0.5 inch long.

The value of the series termination depends on the driver output impedance and the characteristic impedance of the PCB trace. Termination value  $R_s = \text{characteristic impedance } Z_0 - \text{driver output impedance } R_o$ .

#### 5.7 Twisted Pair Interface

The Twisted Pair Interface consists of four differential media dependent I/O pairs (MDI\_A, MDI\_B, MDI\_C, and MDI\_D). Each signal is terminated with a 49.9  $\Omega$  resistor. Figure 18 shows a typical connection for channel A. The circuitry of channels A, B, C, and D are identical. The MDI signals are directly connect to 1:1 magnetics. To optimize the performance, National specifies the key parameters for the magnetics. Please refer to Section 5.13.2.

The following is a layout guide line for the MDI section.

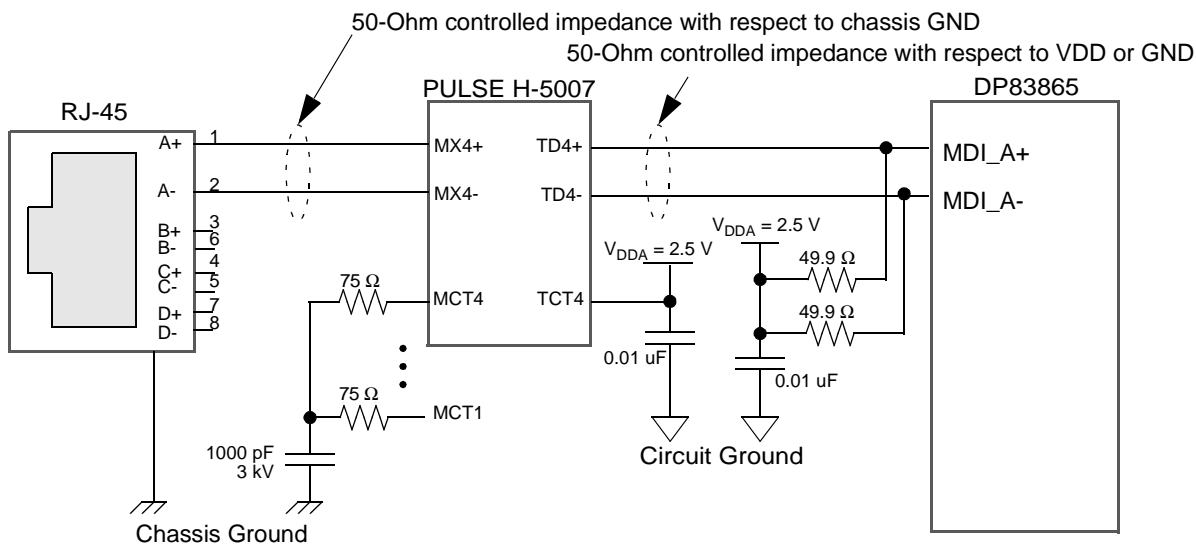

Figure 18. Twisted Pair/Magnetics interface (Channel A)

- Place the 49.9  $\Omega$  1% termination resistors as close as possible to the PHY. Place a 0.01  $\mu\text{F}$  decoupling capacitor for each channel between 2.5V plane and ground close to the termination resistor. Place a 0.01  $\mu\text{F}$  decoupling capacitor for each port at the transformer center tab.
- All the MDI interface traces should have a characteristic impedance of 50 Ohms to the GND or 2.5V plane. This is a strict requirement to minimize return loss.
- Each MDI pair should be placed as close as possible in parallel to minimize EMI and crosstalk. Each member of a pair should be matched in length to prevent mismatch in delay that would cause common mode noise.
- Ideally there should be no crossover or via on the signal paths.

## 5.0 Design Guide (Continued)

### 5.8 RJ-45 Connections

The magnetics isolates local circuitry from other equipment that Ethernet connects to. The IEEE isolation test places stress on the isolated side to test the dielectric strength of the isolation. The center tap of the isolated winding has a "Bob Smith" termination through a  $75\ \Omega$  resistor and 1000 pF cap to chassis ground. The termination capacitor should have voltage tolerance of 3 kV (Figure 18).

To pass EMI compliance tests, there are a few helpful recommendations to follow.

- The RJ-45 is recommended to have metal shielding that connects to chassis ground to reduce EMI emission.
- The isolated side should have the chassis ground "island" placed. The MDI pairs are placed above a continuous chassis ground plane.
- The MDI pairs are suggested to be routed close together in parallel to reduce EMI emission and common mode noise (Figure 19).

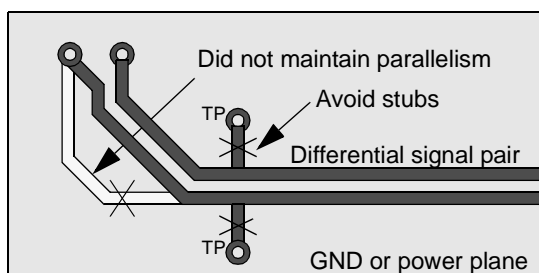

Figure 19. Differential signal pair

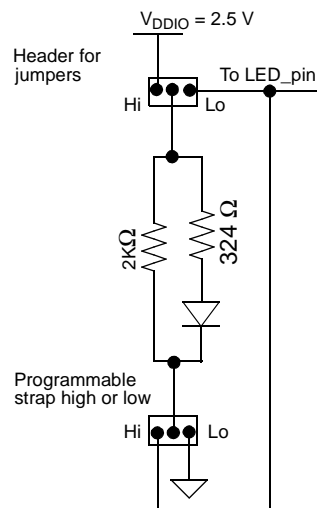
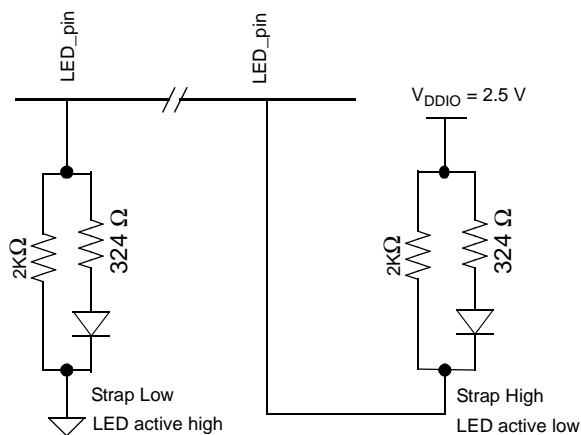

Figure 20. LED/strapping option examples.

### 5.10 Unused Pins and Reserved Pins

Unused CMOS input pins should not be left floating. Floating inputs could have intermediate voltages halfway between VCC and ground and, as a consequence, turning on both the NMOS and the PMOS transistors resulting in high DC current. Floating inputs could also cause oscillations. Therefore unused inputs should be tied high or low. In theory CMOS inputs can be directly tied to VCC or GND.

- The EMI can be further reduced by placing the traces in the inner layers and making the outer layers chassis ground.
- Generally, it is a good practice not to overlap the circuit ground plane with the chassis ground that creates coupling. Instead, make chassis ground an isolated island and make a void between the chassis and circuit ground. Place two or three 1206 pads across the chassis and circuit ground void. This will help when experimentally choosing the appropriate components to pass EMI emission test.

### 5.9 LED/Strapping Option

When the LED outputs are used to drive LEDs directly, the active state of each output driver depends on the logic level sampled by the corresponding strapping input upon power-up or reset. For example, if a given LED/strapping pin is resistively pulled low then the corresponding output is configured as an active high LED driver. Conversely, if a given LED/strapping pin is resistively pulled high then the corresponding output is configured as an active low LED driver. Figure 20 is an example of a LED/strapping configuration.

Care must be taken when the multi-function LED/strapping pins are desired to be programmable. Depending on the strap low or high state, two sets of jumpers could be used (Figure 20). The left side jumper position is connected for the high strap option, and the right side position is connected for the low strap option.

The value of all external pull-up and pull-down resistor should be  $2\ \text{k}\Omega$  in order to make absolutely certain that the correct voltage level is applied to the pin.

## 5.0 Design Guide (Continued)

board space, the adjacent unused input pins can be grouped and tied together with a single resistor.

The number of unused pins and which pins become unused pins highly depend on the individual application the DP83865 is used in. Refer to Section 1.0 for each individual pin that is not used.

Reserved pins must be left floating.

### 5.11 I/O Voltage Considerations

The VDD\_SEL\_STRAP pin selects which I/O voltage (IO\_VDD) is used in an application. The choice is between 2.5V and 3.3V. If the designer was to choose 2.5V an additional 3.3V supply could be saved. However, the decision should not be solely based on saving components but rather on the environment the DP83865 operates in.

IO\_VDD supplies the pins for “MAC Interfaces”, “Management Interface”, “JTAG Interface”, “Device Configuration and LED Interface” and “Reset”. All input pins are either 2.5V or 3.3V compatible. All output pins will have a high level equal to IO\_VDD. The designer must make sure that all connected devices are compatible with the logic ‘1’ state of the DP83865 (that is either 2.5V or 3.3V).

If 2.5V IOVDD is selected, do not over drive the GPHY input with 3.3V logic. The over driving may cause excessive EMI noise and reduce GPHY performance. Over driving may also cause higher power consumption.

### 5.12 Power-up Recommendations

During power-up, the power supply voltages are not available immediately but ramp up relatively slow compared to the clock period of the system clock (CLOCK\_IN). How quickly a supply voltage reaches the “power good” level of

typically 95% of its nominal voltage varies from design to design.

There is no specific requirement for power-up sequence for the DP83865. However, if it is desirable to control the power up order, it is theoretically advised to power up CORE\_VDD supply first. If there is no such ability all supplies can be powered up at the same time. There is no known sequence to date that can cause DP83865 in a latch-up or lock up condition.

In any event, the  $\overline{\text{RESET}}$  signal should be held low until after all power supplies have reached their nominal voltages. See Section 6.2 for additional requirements.

### 5.13 Component Selection

#### 5.13.1 Oscillator

The requirements of 25 Mhz oscillators and crystals are listed in Table 54 and Table 55. Some recommended manufacturers are listed in Table 56.

In the cases where multiple clock sources with the same frequency are needed, it is recommended to use a clock distribution circuit in conjunction with a single frequency generator. These devices may be obtained from vendors such as Texas Instrument, Pericom, and Integrated Device Technology.

Note that the jitter specification was derived from maximum capacitance load, worst case supply voltage, and wide temperature range. The actual allowable jitter number may be significantly higher when driving the DP83865 clock input under normal operating conditions. Please consult the respective vendors for specifics.

**Table 54. 25 MHz Oscillator Requirements**

Parameter	Min	Typ	Max	Units	Condition
Frequency	-	25	-	MHz	-
Frequency Tolerance	-	-	± 50	ppm	0 °C to 70 °C
Frequency Stability	-	-	± 50	ppm	1 year aging
Rise/Fall Time	-	-	6	ns	20 - 80 %
Jitter (short term)	-	-	25	ps	Cycle-to-cycle, driving 10 pF load
Jitter (long term)	-	-	200	ps	Accumulative over 10 $\infty$ s
Symmetry	40	-	60	%	-
Logic 0	-	-	10	%	IO_VDD = 2.5 or 3.3V nominal
Logic 1	90	-	-	%	IO_VDD = 2.5 or 3.3V nominal

**Table 55. 25 MHz Crystal Requirements**

Parameter	Min	Typ	Max	Units	Condition
Frequency	-	25	-	MHz	-
Frequency Tolerance	-	-	± 50	ppm	0 °C to 70 °C
Frequency Stability	-	-	± 50	ppm	1 year aging
Load Capacitance	15	-	40	pF	Total load capacitance including C1 and C2 (see Section 5.2 for dimensioning)

## 5.0 Design Guide (Continued)

**Table 56. Recommended Crystal Oscillators**

<b>Manufacturer</b>	<b>Description</b>	<b>Part Number</b>
Vite Technology www.viteonline.com	25 MHz 7.5 x 5 mm Oscillator	VCC1-B2B-25M000
Raltron www.raltron.com	25 MHz 7.5 x 5 mm Oscillator	C04305L-25.000MHz
Pericom www.saronix.com	25MHz Oscillator	NCH089B3-25.0000
Abrakon www.abrakon.com	25MHz Oscillator	ACSHL-25.0000-E-C-C4
Pletronics www.pletronics.com	25MHz Oscillator	SQ2245V-25.0M-30

**Note:** Contact Oscillator manufactures for latest information on part numbers and product specifications. All Oscillators should be thoroughly tested and validated before using them in production.

## 5.0 Design Guide (Continued)

### 5.13.2 Magnetics

It is important to select the component that meets the requirements. Per IEEE 802.3ab Clause 40.8, the component requirements are listed in Table 57. In addition, the transformer winding should have the configuration shown in Figure 21. The recommended magnetics has an isolation transformer followed by a common mode choke to reduce EMI. There is an additional auto-transformer which is center tapped. To save board space and reduce component count, RJ-45 with integrated magnetics may be used.

The following are magnetics meeting the requirements (Table 57).

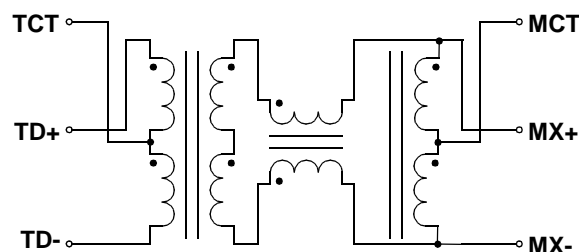

Figure 21. Transformer configuration (1 ch)

Table 57. Magnetics Requirements

Parameter	Min	Typ	Max	Units	Condition
Turn Ratio	-	1:1	-	-	± 1%
Insertion Loss	-	-	-1.1	dB	0.1 - 1 MHz
	-	-	-0.5	dB	1 - 60 MHz
	-	-	-1.0	dB	60 - 100 MHz
	-	-	-1.2	dB	100 - 125 MHz
Return Loss	-18	-	-	dB	1 - 30 MHz
	-14.4	-	-	dB	30 - 40 MHz
	-13.1	-	-	dB	40 - 50 MHz
	-12	-	-	dB	50 - 80 MHz
	-10	-	-	dB	80 - 100 MHz
Differential to Common Rejection Ration	-43	-	-	dB	1 - 30 MHz
	-37	-	-	dB	30 - 60 MHz
	-33	-	-	dB	60 - 100 MHz
Crosstalk	-45	-	-	dB	1 - 30 MHz
	-40	-	-	dB	30 - 60 MHz
	-35	-	-	dB	60 - 100 MHz
Isolation	1,500	-	-	Vrms	HPOT
Rise Time	-	1.6	1.8	ns	10 - 90 %
Primary Inductance	350	-	-	uH	-

Table 58. Recommended Magnetics

Manufacturer	Description	Part Number
Bel Fuse, Inc. www.belfuse.com	10/100/1000 Mbps Isolation Transformer	S558-5999-P3
	10/100/1000 Mbps Isolation Transformer	S558-5999-T3
	10/100/1000 Mbps2X1 Integrated Magnetics	0843-2B1T-33
Delta www.delta.tw	10/100/1000 Mbps Isolation Transformer	LF9203
Halo www.haloelectronics.com	10/100/1000 Mbps Isolation Transformer	TG1G-S002NZ
Midcom www.haloelectronics.com	10/100/1000 Mbps Isolation Transformer	000-7093-37R
Pulse Engineering, Inc. www.pulseeng.com	10/100/1000 Mbps Isolation Transformer	H5007
	10/100/1000 Mbps Isolation Transformer	H5008

**Note:** Contact Magnetics manufactures for latest part numbers and product specifications. All Magnetics should be thoroughly tested and validated before using them in production.

## 6.0 Electrical Specifications

### Absolute Maximum Ratings

Supply Voltage IO_VDD	-0.4V to 4.2 V
Supply Voltage CORE_VDD, 1V8_AVDD1, 1V8_AVDD2	-0.4V to 2.4V
Supply Voltage 2V5_AVDD1, 2V5_AVDD2	-0.4V to 3.6V
Input Voltage (DC <sub>IN</sub> )	-0.5V to IO_VDD + 0.5V
Output Voltage (DC <sub>OUT</sub> )	-0.5V to IO_VDD + 0.5V
Storage Temperature	-65°C to 150°C
ESD Protection	6000V

Note: Absolute maximum ratings are those values beyond which the safety of the device cannot be guaranteed. They are not meant to imply that the device should be operated at these limits.

### Recommended Operating Condition

	Min	Typ	Max	Units
Supply Voltage IO_VDD	3.135	3.3	3.465	V
Supply Voltage IO_VDD	2.375	2.5	2.625	V
Analog Voltages 2V5_AVDD1, 2V5_AVDD2				
Supply Voltage CORE_VDD	1.71	1.8	1.89	V
Analog Voltages 1V8_AVDD1, 1V8_AVDD2				
Ambient Temperature (T <sub>A</sub> )	0		70	°C
CLK_IN Input Freq. Stability (over temperature)	-50		+50	ppm
CLK_IN Input Jitter pk-pk			100	ps
CLK_IN Input Duty Cycle	40		60	%
Center Frequency (f <sub>c</sub> )		25		MHz

### Thermal Characteristics

	Max	Units
Maximum Case Temperature @ 1.0 W	110	°C
Theta Junction to Case (T <sub>jc</sub> ) @ 1.0 W	17	°C / W
Theta Junction to Ambient (T <sub>ja</sub> ) degrees Celsius/Watt - No Airflow @ 1.0 W	47	°C / W

### 6.1 DC Electrical Specification

Symbol	Pin Types	Parameter	Conditions	Min	Typ	Max	Units
V <sub>IH</sub> R/GMII inputs	I I/O I/O_Z	Input High Voltage	IO_VDD of 3.3V or 2.5 V	1.7			V
V <sub>IL</sub> R/GMII inputs	I I/O I/O_Z	Input Low Voltage	IO_VDD of 3.3V or 2.5 V	GND		0.9	V
I <sub>IH</sub> R/GMII	I I/O I/O_Z	Input High Current	V <sub>IN</sub> = IO_VDD			10	∞A
I <sub>IL</sub> R/GMII	I I/O I/O_Z	Input Low Current	V <sub>IN</sub> = GND			10	∞A
V <sub>OH</sub> R/GMII outputs	O, I/O I/O_Z	Output High Voltage	I <sub>OH</sub> = -1.0 mA	2.1		3.6	V
V <sub>OL</sub> R/GMII outputs	O, I/O I/O_Z	Output Low Voltage	I <sub>OL</sub> = 1.0 mA	GND		0.5	V
I <sub>OZ1</sub> R/GMII	I/O_Z	TRI-STATE Leakage	V <sub>OUT</sub> = IO_VDD			10	∞A
I <sub>OZ2</sub> R/GMII	I/O_Z	TRI-STATE Leakage	V <sub>OUT</sub> = GND			-10	∞A
V <sub>IH</sub> non-R/GMII	I I/O I/O_Z	Input High Voltage		2.0		IO_VDD	V



## 6.0 Electrical Specifications (Continued)

Symbol	Pin Types	Parameter	Conditions	Min	Typ	Max	Units
$V_{IL}$ non-R/GMII	I I/O I/O_Z	Input Low Voltage		GND		0.8	V
$V_{OH}$ non-R/GMII	O, I/O I/O_Z	Output High Voltage	IO_VDD = 2.5V IO_VDD = 3.3V $I_{OH} = -4.0$ mA for both	(IO_VDD - 0.5)		IO_VDD	V
$V_{OL}$ non-R/GMII	O, I/O I/O_Z	Output Low Voltage	$I_{OL} = 4.0$ mA	GND		0.4	V
R strap	Strap	PU/PD internal resistor value.			20 - 70		k $\Omega$
$C_{IN1}$	I	CMOS Input Capacitance			8		pF
$C_{OUT1}$	O, I/O I/O_Z	CMOS Output Capacitance			8		pF
$R_0$ R/GMII	O, I/O_Z	Output impedance	$V_{OUT} = IO\_VDD / 2$		35		Ohm
$V_{OD-10}$	(MDI)	10 M Transmit $V_{DIFF}$		2.2	2.5	2.8	V peak differential
$V_{OD-100}$	(MDI)	100 M Transmit $V_{DIFF}$	Note 1	0.950	1.0	1.050	V peak differential
$V_{OD-1000}$	(MDI)	1000 M Transmit $V_{DIFF}$		0.67	0.745	0.82	V peak differential

**Note 1:** Guaranteed by design.

## 6.0 Electrical Specifications (Continued)

### 6.2 Reset Timing

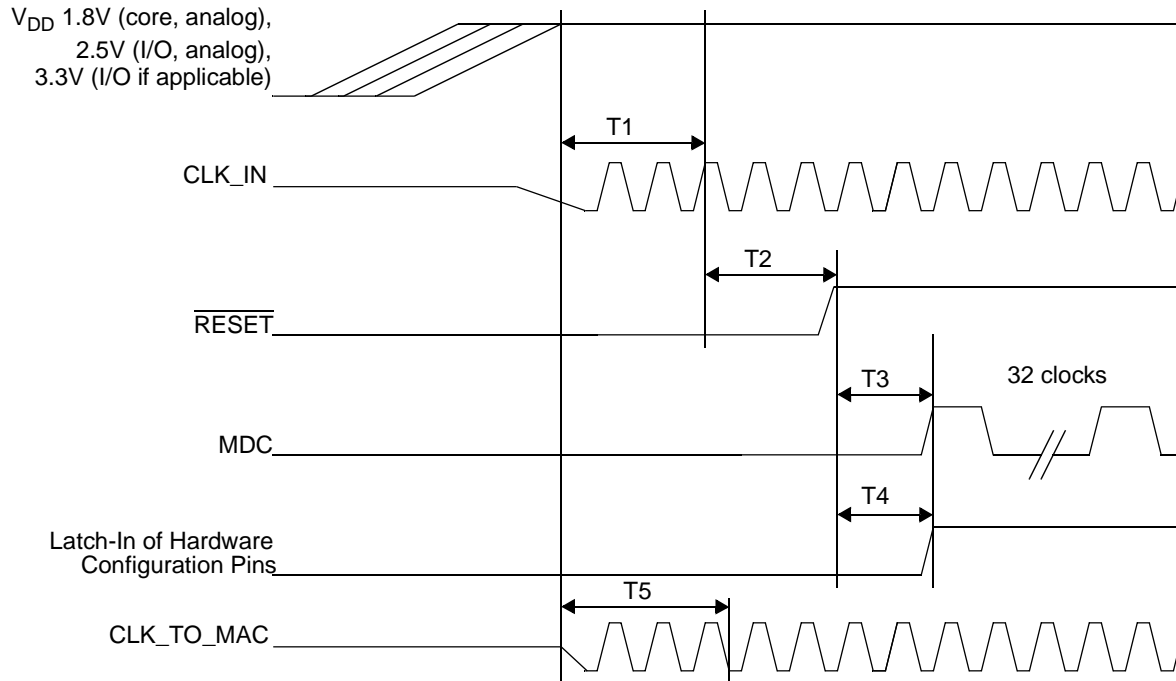

Parameter	Description	Notes	Min	Typ	Max	Units
T1	Reference clock settle time	The reference clock must be stable after the last power supply voltage has settled and before $\overline{\text{RESET}}$ is deasserted. (Note 1) Pins VDD_SEL and CLK_MAC_EN are latched in during this time.	0			$\infty$ s
T2	Hardware $\overline{\text{RESET}}$ Pulse Width	Power supply voltages and the reference clock (CLK_IN) have to be stable.	150			$\infty$ s
T3	Post $\overline{\text{RESET}}$ Stabilization time prior to MDC preamble for register accesses	MDIO is pulled high for 32-bit serial management initialization.	20			ms
T4	External pull configuration latch-in time from the deassertion of $\overline{\text{RESET}}$	Hardware Configuration Pins are described in the Pin Description section. Reset includes external hardware and internal software through registers. (Note 2)	20			ms
T5	CLK_TO_MAC Output Stabilization Time	If enabled, the CLK_TO_MAC output, being independent of $\overline{\text{RESET}}$ , power-down mode and isolation mode, is available after power-up. CLK_TO_MAC is a buffered output CLK_IN. (Note 1)	0 + T1			$\infty$ s

**Note 1:** Guaranteed by design. Not tested.

**Note 2:** It is recommended to use external pull-up and/or pull-down resistors for each of the hardware configuration pins that provide fast RC time constants in order to latch-in the proper value prior to the pin transitioning to an output driver. Unless otherwise noted in the Pin Description section all external pull-up or pull-down resistors are recommended to be 2k $\Omega$ .

## 6.0 Electrical Specifications (Continued)

### 6.3 Clock Timing

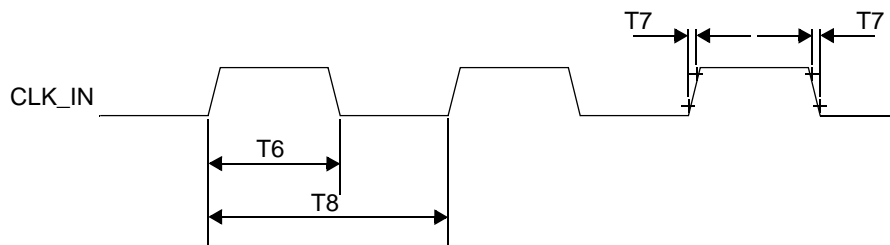

Parameter	Description	Notes	Min	Typ	Max	Units
T6	CLK_IN Duty Cycle		40		60	%
T7	CLK_IN $t_R/t_F$	10% to 90%		1.0 to 2.5		ns
T8	CLK_IN frequency (25 MHz +/-50 ppm)		24.99875	25.000000	25.001250	MHz

### 6.4 1000 Mb/s Timing

#### 6.4.1 GMII Transmit Interface Timing

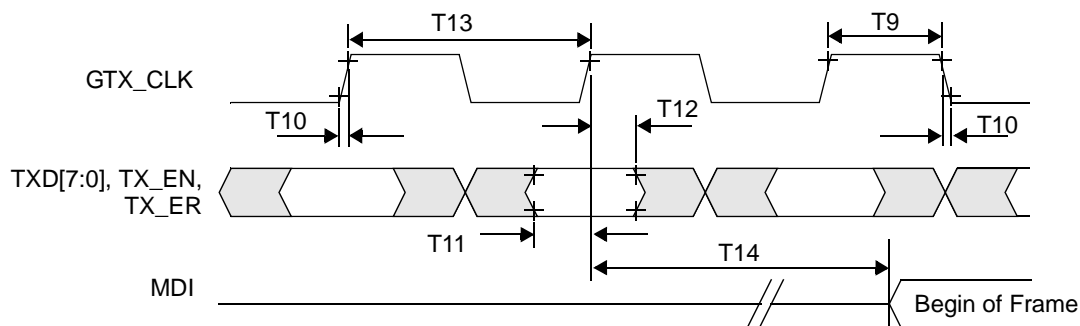

Parameter	Description	Notes	Min	Typ	Max	Units
T9	GTX_CLK Duty Cycle		40		60	%
T10	GTX_CLK $t_R/t_F$	Note 1,4,5			1	ns
T11	Setup from valid TXD, TX_EN and TXER to $\uparrow$ GTX_CLK	Note 2,4	2.0			ns
T12	Hold from $\uparrow$ GTX_CLK to invalid TXD, TX_EN and TXER	Note 3,4	0.0			ns
T13	GTX_CLK Stability	Note 5	-100		+100	ppm
T14	GMII to MDI latency			152		ns

**Note 1:**  $t_r$  and  $t_f$  are measured from  $V_{IL\_AC(MAX)} = 0.7V$  to  $V_{IH\_AC(MIN)} = 1.9V$ .

**Note 2:**  $t_{setup}$  is measured from data level of 1.9V to clock level of 0.7V for data = '1'; and data level = 0.7V to clock level 0.7V for data = '0'.

**Note 3:**  $t_{hold}$  is measured from clock level of 1.9V to data level of 1.9V for data = '1'; and clock level = 1.9V to data level 0.7V for data = '0'.

**Note 4:** GMII Receiver input template measured with "GMII point-to-point test circuit", see Test Conditions Section

**Note 5:** Guaranteed by design. Not tested.

## 6.0 Electrical Specifications (Continued)

### 6.4.2 GMII Receive Timing

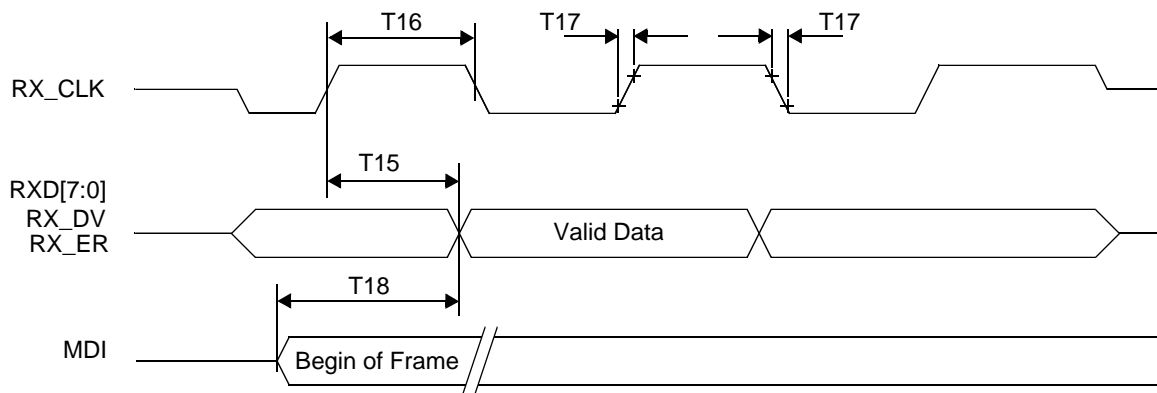

Parameter	Description	Notes	Min	Typ	Max	Units
T15	↑ RX_CLK to RXD, RX_DV and RX_ER delay	Note 2, 3, 4	0.5		5.5	ns
T16	RX_CLK Duty Cycle		40		60	%
T17	RX_CLK $t_R/t_F$	Note 1, 4, 5			1	ns
T18	MDI to GMII latency			384		ns

**Note 1:**  $t_r$  and  $t_f$  are measured from  $V_{IL\_AC(MAX)} = 0.7V$  to  $V_{IH\_AC(MIN)} = 1.9V$ .

**Note 2:**  $t_{delay\ max}$  is measured from clock level of 0.7V to data level of 1.9V for data = '1'; and clock level = 0.7V to data level 0.7V for data = '0'.

**Note 3:**  $t_{delay\ min}$  is measured from clock level of 1.9V to data level of 1.9V for data = '1'; and clock level = 1.9V to data level 0.7V for data = '0'.

**Note 4:** GMII Receiver input template measured with "GMII point-to-point test circuit", see Test Conditions Section.

**Note 5:** Guaranteed by design. Not tested.

## 6.0 Electrical Specifications (Continued)

### 6.5 RGMII Timing

#### 6.5.1 Transmit and Receive Multiplexing and Timing

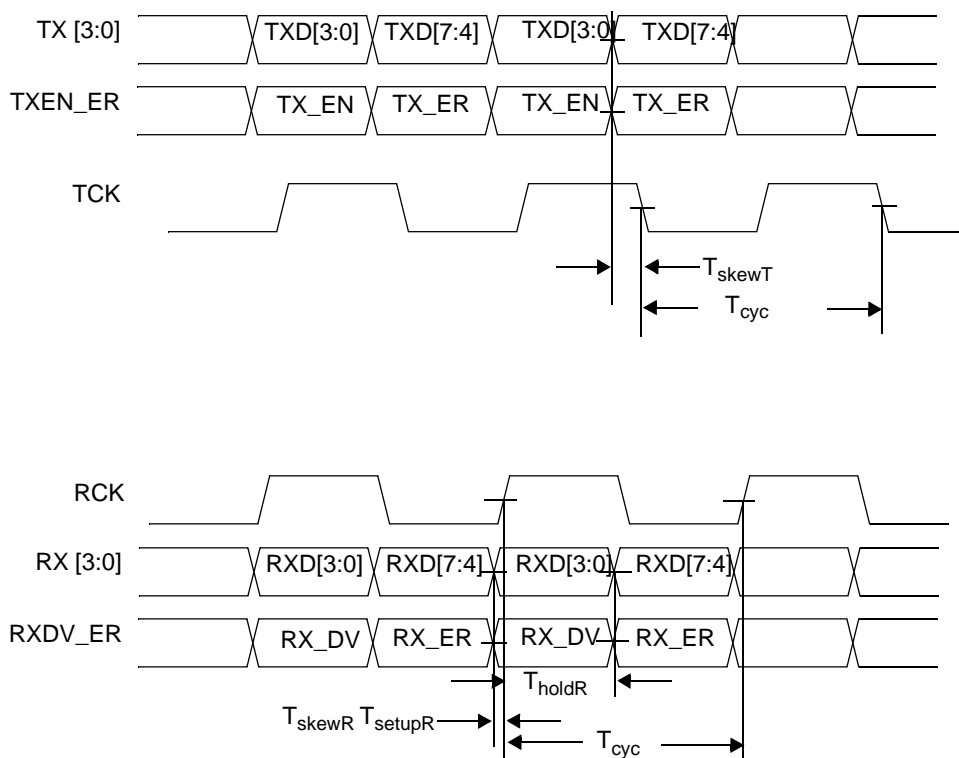

Parameter	Description	Notes	Min	Typ	Max	Units
$T_{skewT}$	TX to Clock skew (at receiver, PHY), HP mode	Note 1	1.0		2.0	ns
$T_{skewT}$	TX to Clock skew (at receiver, PHY), 3COM mode	Note 4	-900		900	ps
$T_{skewR}$	RX to Clock skew (at transmitter, PHY), HP mode	Note 4	-500		500	ps
$T_{setupR}$	RX to Clock setup (at transmitter, PHY), 3COM mode	Note 4	1.4			ns
$T_{holdR}$	RX to Clock hold (at transmitter, PHY), 3COM mode	Note 4	1.2			ns
$T_{cyc}$	Clock Period	Note 2, 4	7.2	8	8.8	ns
$T_{Duty\_G}$	Duty Cycle for gigabit	Note 3	45	50	55	%
$T_{Duty\_T}$	Duty Cycle for 10/100 BASE-T	Note 3	40	50	60	%
$T_r/T_f$	Rise/Fall Time (20 -80%)	Note 4			1.0	ns

**Note 1:** The PC board design requires clocks to be routed such that an additional trace delay of greater than 1.5 ns is added to the associated clock signal.

**Note 2:** For 10 Mbps and 100 Mbps,  $T_{cyc}$  will scale to 400ns +/-40ns and 40ns +/-4ns.

**Note 3:** Duty cycle may be stretched or shrunk during speed changes or while transitioning to a received packet's clock domain as long as minimum duty cycle is not violated and stretching occurs for no more that three  $T_{cyc}$  of the lowest speed transitioned between.

**Note 4:** Guaranteed by design. Not tested.

## 6.0 Electrical Specifications (Continued)

### 6.6 100 Mb/s Timing

#### 6.6.1 100 Mb/s MII Transmit Timing

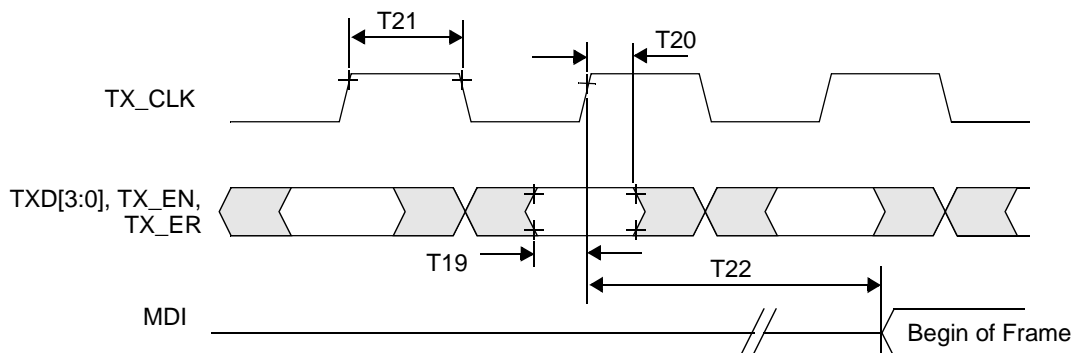

Parameter	Description	Notes	Min	Typ	Max	Units
T19	TXD[3:0], TX_EN and TX_ER Setup to $\uparrow$ TX_CLK		10			ns
T20	TXD[3:0], TX_EN and TX_ER Hold from $\uparrow$ TX_CLK		-1			ns
T21	TX_CLK Duty Cycle		40		60	%
T22	MII to MDI latency			136		ns

#### 6.6.2 100 Mb/s MII Receive Timing

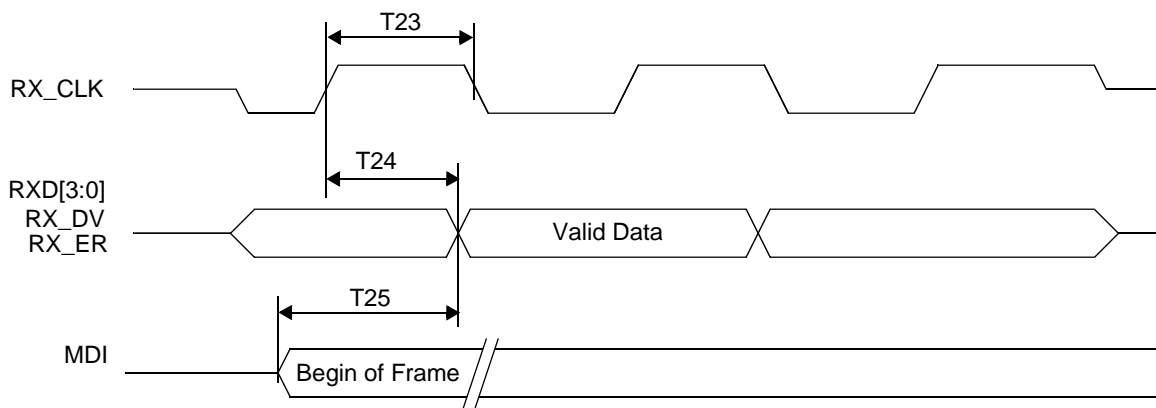

Parameter	Description	Notes	Min	Typ	Max	Units
T23	RX_CLK Duty Cycle		35		65	%
T24	$\uparrow$ RX_CLK to RXD[3:0], RX_DV, RX_ER Delay		10		30	ns
T25	MDI to MII latency			288		ns

## 6.0 Electrical Specifications (Continued)

### 6.7 10 Mb/s Timing

#### 6.7.1 10 Mb/s MII Transmit Timing

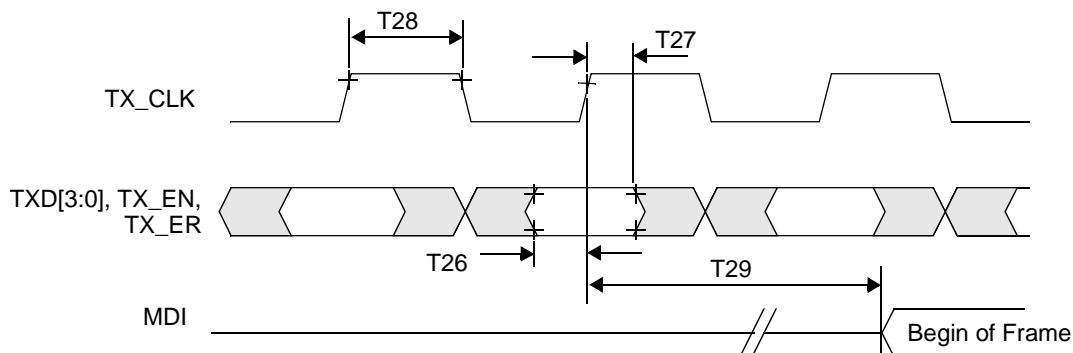

Parameter	Description	Notes	Min	Typ	Max	Units
T26	TXD[3:0], TX_EN and TX_ER Setup to $\uparrow$ TX_CLK		100			ns
T27	TXD[3:0], TX_EN and TX_ER Hold from $\uparrow$ TX_CLK		0			ns
T28	TX_CLK Duty Cycle		40		60	%
T29	MII to MDI latency			125		ns

#### 6.7.2 10 Mb/s MII Receive Timing

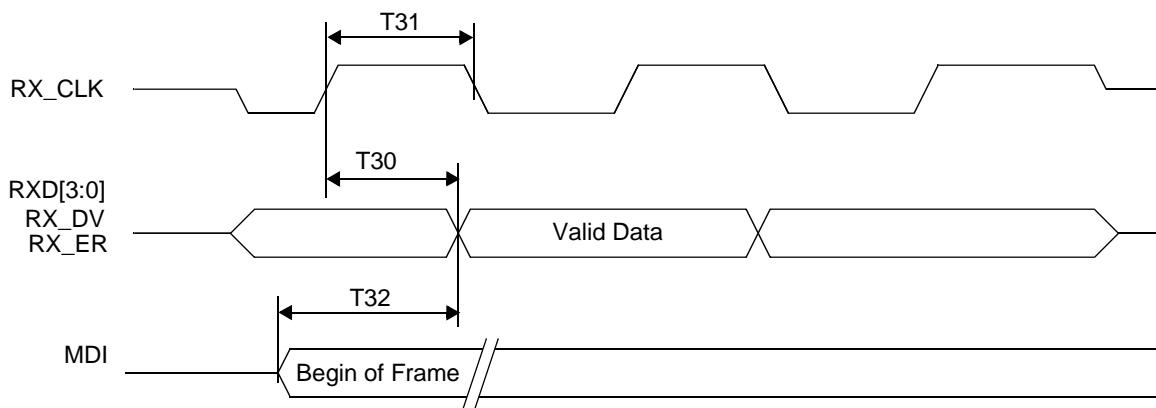

Parameter	Description	Notes	Min	Typ	Max	Units
T30	$\uparrow$ RX_CLK to RXD[3:0], RX_DV, RX_ER Delay		100		300	ns
T31	RX_CLK Duty Cycle		35		65	%
T32	MDI to MII latency			1125		ns

## 6.0 Electrical Specifications (Continued)

### 6.8 Loopback Timing

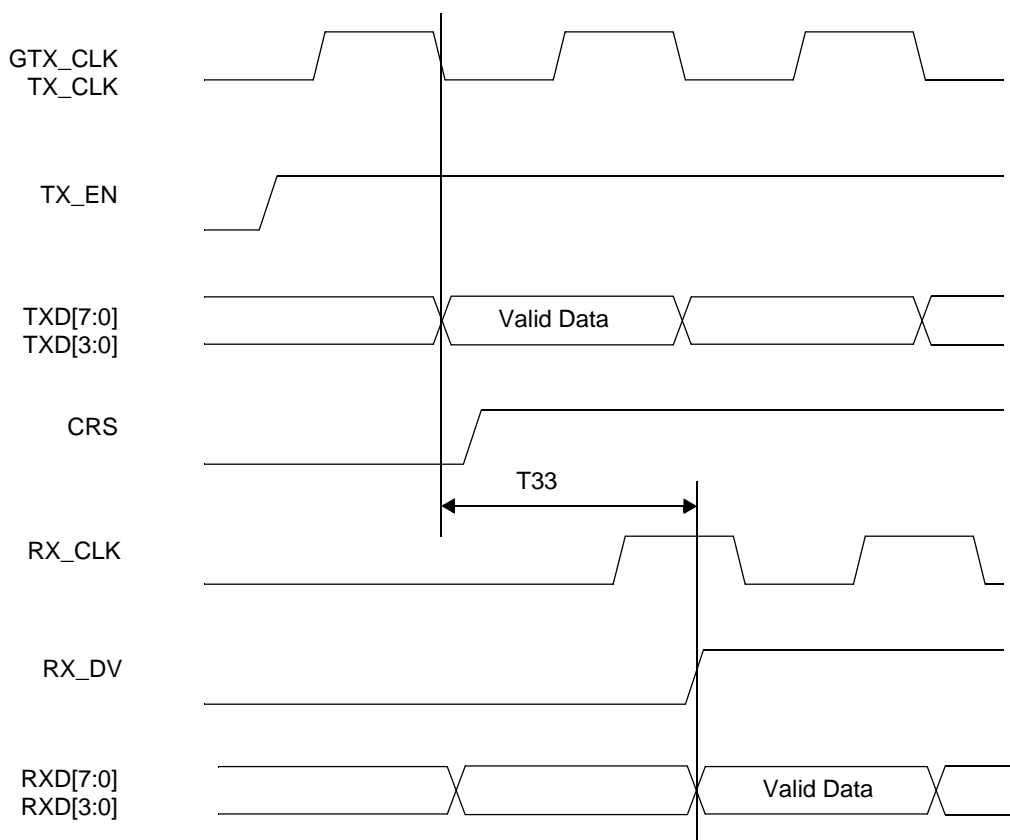

Parameter	Description	Notes	Min	Typ	Max	Units
T33	TX_EN to RX_DV Loopback	10 Mb/s 100 Mb/s 1000 Mb/s		2220 380 536		ns

**Note:** During loopback (all modes) both the TD± outputs remain inactive by default.



## 6.0 Electrical Specifications (Continued)

### 6.9 Serial Management Interface Timing

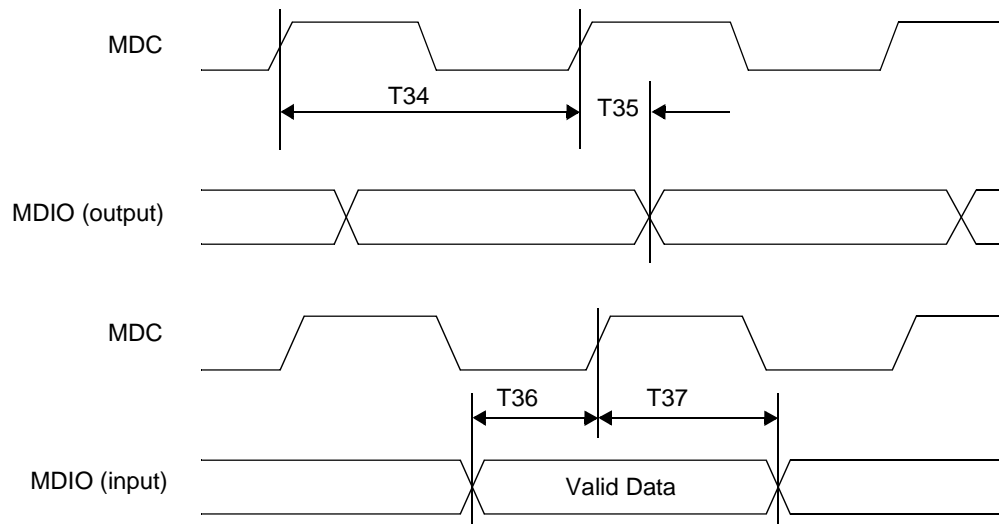

Parameter	Description	Notes	Min	Typ	Max	Units
T34	MDC Frequency				2.5	MHz
T35	MDC to MDIO (Output) Delay Time		0		300	ns
T36	MDIO (Input) to MDC Setup Time		10			ns
T37	MDIO (Input) to MDC Hold Time		10			ns

## 6.0 Electrical Specifications (Continued)

### 6.10 Power Consumption

Symbol	Pin Types	Parameter	Conditions	Min	Typ	Max	Units
$I_{1V8\_1000}$		1V8_AVDD, 1V8 Core_VDD current	Core_VDD = 1.8V, 1V8_AVDD = 1.8V, 1000 Mbps FDX		0.43		A
$I_{2V5\_1000}$		2V5_AVDD current	2V5_AVDD = 2.5V, 1000 Mbps FDX		0.19		A
$I_{2V5\_IO\_1000}$		IO_VDD current	IO_VDD = 2.5V, 1000 Mbps FDX		0.01		A
$I_{3V3\_IO\_1000}$		IO_VDD current	IO_VDD = 3.3V, 1000 Mbps FDX		0.01		A
$I_{1V8\_100}$		1V8_AVDD, 1V8 Core_VDD current	Core_VDD = 1.8V, 1V8_AVDD = 1.8V, 100 Mbps FDX		0.07		A
$I_{2V5\_100}$		2V5_AVDD, IO_VDD current	IO_VDD = 2.5V, 2V5_AVDD = 2.5V, 100 Mbps FDX		0.06		A
$I_{2V5\_IO\_100}$		IO_VDD current	IO_VDD = 2.5V, 100 Mbps FDX		0.01		A
$I_{3V3\_IO\_100}$		IO_VDD current	IO_VDD = 3.3V, 100 Mbps FDX		0.01		A

## 7.0 Frequently Asked Questions

### 7.1 Do I need to access any MDIO register to start up the PHY?

**A:** The answer is no. The PHY is a self contained device. The initial settings of the PHY are configured by the strapping option at the pins. The PHY will start normal operation based on the strapping options upon power up or reset.

### 7.2 I am trying to access the registers through MDIO and I got invalid data. What should I do?

- A:** There are a number of items that you need to check.
- Make sure the MDC frequency is not greater than 2.5 MHz.
  - Check if the MDIO data line has a 2K pull up resistor and the line is idling high.
  - Verify the data timing against the datasheet.
  - Be sure the turn around time (TA) is at least 1 bit long.

### 7.3 Why can the PHY establish a valid link but can not transmit or receive data?

**A:** PHY is a self contained device. The PHY can establish link by itself without any MAC and management involvement. Here are some suggestions to isolate the problem.

- Use MDIO management access to configure the BIST registers to transmit packet. If link partner can receive data, the problem may lie in the MAC interface.
- Check the MAC transmit timing against the PHY datasheet.
- Verify the receive timing of the MAC device to see if it matches the PHY datasheet.
- If the PHY receives the data correctly, the activity LED should turn on.
- Start the debugging at the slower 10 Mbps or 100 Mbps speed.
- Enable the loopback at register 0x00.14. Verify that you can receive the data that you transmit.

### 7.4 What is the difference between TX\_CLK, TX\_TCLK, and GTX\_CLK?

**A:** All the 3 clocks above are related to transmitting data. However, their functions are different:

**TX\_CLK:** The TX\_CLK is an output of the PHY and is part of the MII interface as described in IEEE 802.3u specification, Clause 28.

This is used for 10/100 Mbps transmit activity. It has two separate functions:

- It is used to synchronize the data sent by the MAC and to latch this data into the PHY.
- It is used to clock transmit data on the twisted pair.

**GTX\_CLK:** The GTX\_CLK is an output of the MAC and is part of the GMII interface as described in IEEE 802.3z specification, Clause 35.

This is used for 1000 Mbps transmit activity. It has only one function:

- It is used to synchronize the data sent by the MAC and to latch this data into the PHY.

The GTX\_CLK is NOT used to transmit data on the twisted pair wire. For 1000 Mbps operation, the Master PHY uses

the internal 125 MHz clock generated from the CLOCK\_IN clock to transmit data on the wire. The Slave PHY uses the clock recovered from the link partner's transmission as the transmit clock for all four pairs.

**TX\_TCLK:** The TX\_TCLK is an output of the PHY and can be enabled to come out on pin 6 (during Test Mode 2 and 3 it is automatically enabled). This is a requirement from the IEEE 802.3ab specification, Clause 40.6.1.2.5.

This is used for 1000 Mbps transmit activity. It has only one function:

- It is used in "Test Modes 2 & 3" to measure jitter in the data transmitted on the wire.

Either the reference clock or the clock recovered from received data is used for transmitting data; depending on whether the PHY is in MASTER or SLAVE mode. TX\_TCLK represents the actual clock being used to transmit data.

### 7.5 What happens to the TX\_CLK during 1000 Mbps operation? Similarly what happens to RXD[4:7] during 10/100 Mbps operation?

**A:** TX\_CLK is not used during the 1000 Mbps operation, and the RXD[4:7] lines are not used for the 10/100 operation. These signals are outputs of the Gig PHYTER V. To simplify the MII/GMII interface, these signals are driven actively to a zero volt level. This eliminates the need for pull-down resistors.

### 7.6 What happens to the TX\_CLK and RX\_CLK during Auto-Negotiation and during idles?

**A:** During Auto-Negotiation the Gig PHYTER V drives a 25 MHz clock on the TX\_CLK and RX\_CLK lines. After a valid link is established and during idle time, these lines are driven at 2.5 MHz in 10 Mbps, and at 25 MHz in 100 Mbps mode. In 1000 Mbps mode only RX\_CLK is driven at 125 MHz.

### 7.7 Why doesn't the Gig PHYTER V complete Auto-Negotiation if the link partner is a forced 1000 Mbps PHY?

**A:** IEEE specifications define "parallel detection" for 10/100 Mbps operation only. Parallel detection is the name given to the Auto-Negotiation process where one of the link partners is Auto-Negotiating while the other is in forced 10 or 100 Mbps mode. In this case, it is expected that the Auto-Negotiating PHY establishes half-duplex link at the forced speed of the link partner.

However, for 1000 Mbps operation this parallel detection mechanism is not defined. Instead, any 1000BASE-T PHY can establish 1000 Mbps operation with a link partner in the following two cases:

- When both PHYs are Auto-Negotiating,
- When both PHYs are forced 1000 Mbps. Note that one of the PHYs is manually configured as MASTER and the other is manually configured as SLAVE.

### 7.8 What determines Master/Slave mode when Auto-Negotiation is disabled in 1000Base-T mode?

**A:** Disabling 1000 Base-T Auto-Negotiation forces the PHY to operate in Master or Slave mode. The selection is through MULTI\_EN pin. Since there is no way of knowing

## 7.0 Frequently Asked Questions (Continued)

in advance what mode the link partner is operating, there could be conflict if both PHY are operating in Master or both in Slave mode. It is recommended that under normal operation, AN\_EN is enabled.

### 7.9 How long does Auto-Negotiation take?

**A:** Two PHY's typically complete Auto-Negotiation and establish 1000 Mbps operation in less than 5 seconds. 1000BASE-T Auto-Negotiation process takes longer than the 10/100 Mbps. The gigabit negotiation does Next Page exchanges and extensive line adaptation.

### 7.10 How do I measure FLP's?

**A:** In order measure FLP's Auto MDIX function must be disabled. When in Auto MDIX mode the DP83865 outputs link pulses every 150 ns. Note that MDIX pulse should not be confused with the FLP pulses which occur every 125 ns +/- 14 ns. To disable Auto MDIX, AUX\_CTL 0x12.15 = 0.

Once Auto MDIX is disabled register bit 0x12.14 specifies MDIX mode. '1' for MDIX cross over mode and '0' for straight mode. In crossover mode, the FLP appears on pins 3-6 of RJ-45 and in straight mode, the FLP appears on pins 1-2.

### 7.11 I have forced 10 Mbps or 100 Mbps operation but the associated speed LED doesn't come on.

**A:** Speed LEDs are actually an AND function of the speed and link status. Regardless of whether the speed is forced or Auto-Negotiated, there has to be good link for the speed LEDs to turn on.

### 7.12 I know I have good link, but register 0x01, bit 2 "Link Status" doesn't contain value '1' indicating good link.

**A:** This bit is defined by IEEE 802.3u Clause 22. It indicates if the link was lost since the last time this register was read. Its name (given by IEEE) is perhaps misleading. A more accurate name would have been the "Link lost" bit. If the actual present link status is desired, then either this register should be read twice, or register 0x11 bit 2 should be read. Register 0x11 shows the actual status of link, speed, and duplex regardless of what was advertised or what has happened in the interim.

### 7.13 Your reference design shows pull-up or pull-down resistors attached to certain pins, which conflict with the pull-up or pull-down information specified in the datasheet?

**A:** The pull-up or pull-down information specified in the pin description section of the datasheet, indicate if there is an internal pull-up or pull-down resistor at the IO buffer used for that specific pin. These resistors are between 25 - 80 kΩ. They will determine the default strap value when the pin is floating. If the default value is desired to be changed, an external 2 kΩ pull-up or pull-down resistor can be used.

### 7.14 How is the maximum package case temperature calculated?

**A:** The maximum die temperature is calculated using the following equations:

$$T_J = T_A + P_d(O_{JA})$$

$$T_J = T_C + P_d(O_C)$$

$$T_C = T_J - P_d(O_C)$$

Where:

$T_J$  = Junction temperature of the die in °C

$T_C$  = Case temperature of the package in °C

$P_d$  = Power dissipated in the die in Watts

$O_C$  = 17°C/watt

For reliability purposes the maximum junction should be kept below 120 °C. If the Ambient temperature is 70 °C and the power dissipation is 1.2 watts then the Maximum Case Temperature should be maintained at:

$$T_{C \max} = 120^\circ\text{C} - 1.1 \text{ watts} * (17^\circ\text{C/watt})$$

$$T_{C \max} = 101^\circ\text{C}$$

### 7.15 The DP83865 will establish Link in 100 Mbps mode with a Broadcom part, but it will not establish link in 1000 Mbps mode. When this happens the DP83865's Link LED will blink on and off.

**A:** We have received a number of questions regarding inter-operability of National's DP83865 with Broadcom's BCM5400 1000/100 Mbps PHY. National's DP83865 is compliant to IEEE 802.3ab and it is also inter-operable with the BCM5400 as well as other Gigabit Physical Layer products. However, there are certain situations that might require extra attention when inter-operating with the BCM5400.

There are two types of BCM5400's, those with silicon revisions earlier than C5 and those with silicon revisions of C5 and older. There is a fundamental problem with earlier silicon revisions of the BCM 5400, whereby the part was designed with faulty start-up conditions (wrong polynomials were used) which prevented the Broadcom BCM5400 from ever linking to an IEEE 802.3ab compliant part.

This problem was observed in early inter-operability testing at National Semiconductor. A solution was put together that allows the DP83865 to inter-operate with any IEEE 802.3ab compliant Gigabit PHY as well as with earlier revisions of the BCM5400 that are non compliant. To enter into this mode of operation you can either pull pin 1 (NON\_IEEE\_STRAP) high through a 2kΩ resistor or write '1' to bit 9 of register 0x12.

### 7.16 How do I quickly determine the quality of the link over the cable ?

**A:** Idle error indicates either that the cable length is beyond the specified limit or the cable plant does not meet the EIA 568 Category V requirements. The Activity LED indicates the occurrence of idle error or packet transfer. You monitor the quality of the link by viewing the Activity LED during idle.

### 7.17 What is the power up sequence for DP83865?

**A:** The DP83865 has two types of power supplies, core and I/O. Although there has not been revealing of power up sequence error such as latch up or dead lock, it is recommended that core power takes precedence over the I/O power when powering up. 1.8V should be up before 2.5V and 3.3V. When powering down, I/O takes precedence over core. 2.5V and 3.3V should be turned off before 1.8V.

## 7.0 Frequently Asked Questions (Continued)

### 7.18 What are some other applicable documents?

**A:** For updated collateral material, please go to “solutions.national.com” website.

- DP83865 Reference Design (Demo board, Schematics, BOM, Gerber files.)
- Application Note 1263 “DP83865 Gig PHYTER V 10/100/1000 Ethernet Physical Layer Design Guide”
- Application Note 1337 “Design Migration from DP83861 to DP83865”
- Application Note 1301 “Dual Foot Print Layout Notes for DP83865 Gig PHYTER V and DP83847 DS PHYTER II”
- Application Note 1329 “DP83865 and DP83864 Gigabit Physical Layer Device Trouble Shooting Guide”
- IEEE 802.3z “MAC Parameters, Physical Layer, Repeater and Management Parameters for 1000 Mbps Operation.”
- IEEE 802.3ab “Physical layer specification for 1000 Mbps operation on four pairs of category 5 or better balanced twisted pair cable (1000BASE-T)“.
- IEEE 802.3 and 802.3u (For 10/100 Mbps operation.)

**NOTES**

**8.0 Physical Dimensions** inches (millimeters) unless otherwise noted

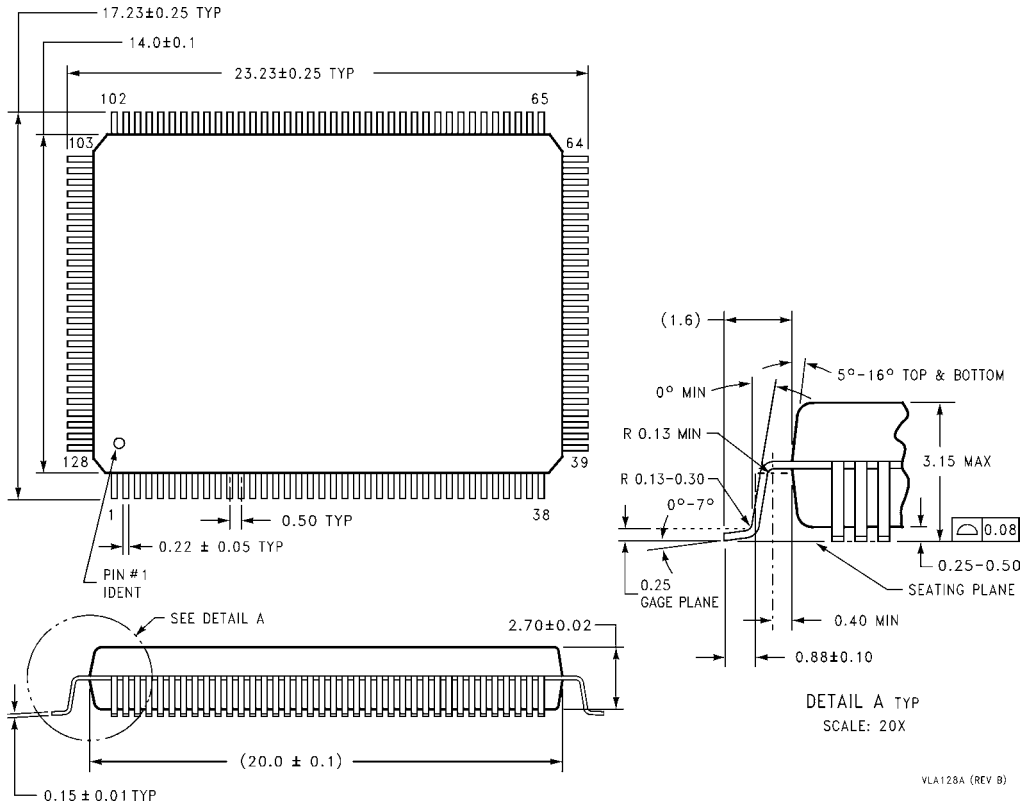

**128 Lead Plastic Flat Pack**

**LIFE SUPPORT POLICY**

NATIONAL'S PRODUCTS ARE NOT AUTHORIZED FOR USE AS CRITICAL COMPONENTS IN LIFE SUPPORT DEVICES OR SYSTEMS WITHOUT THE EXPRESS WRITTEN APPROVAL OF THE PRESIDENT AND GENERAL COUNSEL OF NATIONAL SEMICONDUCTOR CORPORATION. As used herein:

1. Life support devices or systems are devices or systems which, (a) are intended for surgical implant into the body, or (b) support or sustain life, and whose failure to perform, when properly used in accordance with instructions for use provided in the labeling, can be reasonably expected to result in a significant injury to the user.
2. A critical component is any component of a life support device or system whose failure to perform can be reasonably expected to cause the failure of the life support device or system, or to affect its safety or effectiveness.

**BANNED SUBSTANCE COMPLIANCE**

National Semiconductor certifies that the products and packing materials meet the provisions of the Customer Products Stewardship Specification (CSP-9-111C2) and the Banned Substances and Materials of Interest Specification (CSP-9-111S2) and contain no "Banned Substances" as defined in CSP-9-111S2.



**National Semiconductor Corporation**  
 Tel: 1-800-272-9959  
 Fax: 1-800-737-7018  
 Email: support@nsc.com

**National Semiconductor Europe**  
 Fax: +49 (0) 180-530 85 86  
 Email: europe.support@nsc.com  
 Deutsch Tel: +49 (0) 69 9508 6208  
 English Tel: +44 (0) 870 24 0 2171  
 Francais Tel: +33 (0) 1 41 91 8790

**National Semiconductor Asia Pacific Customer Response Group**  
 Tel: 65-254-4466  
 Fax: 65-250-4466  
 Email: ap.support@nsc.com

**National Semiconductor Japan Ltd.**  
 Tel: 81-3-5639-7560  
 Fax: 81-3-5639-7507

www.national.com

## IMPORTANT NOTICE

Texas Instruments Incorporated and its subsidiaries (TI) reserve the right to make corrections, modifications, enhancements, improvements, and other changes to its products and services at any time and to discontinue any product or service without notice. Customers should obtain the latest relevant information before placing orders and should verify that such information is current and complete. All products are sold subject to TI's terms and conditions of sale supplied at the time of order acknowledgment.

TI warrants performance of its hardware products to the specifications applicable at the time of sale in accordance with TI's standard warranty. Testing and other quality control techniques are used to the extent TI deems necessary to support this warranty. Except where mandated by government requirements, testing of all parameters of each product is not necessarily performed.

TI assumes no liability for applications assistance or customer product design. Customers are responsible for their products and applications using TI components. To minimize the risks associated with customer products and applications, customers should provide adequate design and operating safeguards.

TI does not warrant or represent that any license, either express or implied, is granted under any TI patent right, copyright, mask work right, or other TI intellectual property right relating to any combination, machine, or process in which TI products or services are used. Information published by TI regarding third-party products or services does not constitute a license from TI to use such products or services or a warranty or endorsement thereof. Use of such information may require a license from a third party under the patents or other intellectual property of the third party, or a license from TI under the patents or other intellectual property of TI.

Reproduction of TI information in TI data books or data sheets is permissible only if reproduction is without alteration and is accompanied by all associated warranties, conditions, limitations, and notices. Reproduction of this information with alteration is an unfair and deceptive business practice. TI is not responsible or liable for such altered documentation. Information of third parties may be subject to additional restrictions.

Resale of TI products or services with statements different from or beyond the parameters stated by TI for that product or service voids all express and any implied warranties for the associated TI product or service and is an unfair and deceptive business practice. TI is not responsible or liable for any such statements.

TI products are not authorized for use in safety-critical applications (such as life support) where a failure of the TI product would reasonably be expected to cause severe personal injury or death, unless officers of the parties have executed an agreement specifically governing such use. Buyers represent that they have all necessary expertise in the safety and regulatory ramifications of their applications, and acknowledge and agree that they are solely responsible for all legal, regulatory and safety-related requirements concerning their products and any use of TI products in such safety-critical applications, notwithstanding any applications-related information or support that may be provided by TI. Further, Buyers must fully indemnify TI and its representatives against any damages arising out of the use of TI products in such safety-critical applications.

TI products are neither designed nor intended for use in military/aerospace applications or environments unless the TI products are specifically designated by TI as military-grade or "enhanced plastic." Only products designated by TI as military-grade meet military specifications. Buyers acknowledge and agree that any such use of TI products which TI has not designated as military-grade is solely at the Buyer's risk, and that they are solely responsible for compliance with all legal and regulatory requirements in connection with such use.

TI products are neither designed nor intended for use in automotive applications or environments unless the specific TI products are designated by TI as compliant with ISO/TS 16949 requirements. Buyers acknowledge and agree that, if they use any non-designated products in automotive applications, TI will not be responsible for any failure to meet such requirements.

Following are URLs where you can obtain information on other Texas Instruments products and application solutions:

### Products

Audio	<a href="http://www.ti.com/audio">www.ti.com/audio</a>
Amplifiers	<a href="http://amplifier.ti.com">amplifier.ti.com</a>
Data Converters	<a href="http://dataconverter.ti.com">dataconverter.ti.com</a>
DLP® Products	<a href="http://www.dlp.com">www.dlp.com</a>
DSP	<a href="http://dsp.ti.com">dsp.ti.com</a>
Clocks and Timers	<a href="http://www.ti.com/clocks">www.ti.com/clocks</a>
Interface	<a href="http://interface.ti.com">interface.ti.com</a>
Logic	<a href="http://logic.ti.com">logic.ti.com</a>
Power Mgmt	<a href="http://power.ti.com">power.ti.com</a>
Microcontrollers	<a href="http://microcontroller.ti.com">microcontroller.ti.com</a>
RFID	<a href="http://www.ti-rfid.com">www.ti-rfid.com</a>
OMAP Mobile Processors	<a href="http://www.ti.com/omap">www.ti.com/omap</a>
Wireless Connectivity	<a href="http://www.ti.com/wirelessconnectivity">www.ti.com/wirelessconnectivity</a>

### Applications

Communications and Telecom	<a href="http://www.ti.com/communications">www.ti.com/communications</a>
Computers and Peripherals	<a href="http://www.ti.com/computers">www.ti.com/computers</a>
Consumer Electronics	<a href="http://www.ti.com/consumer-apps">www.ti.com/consumer-apps</a>
Energy and Lighting	<a href="http://www.ti.com/energy">www.ti.com/energy</a>
Industrial	<a href="http://www.ti.com/industrial">www.ti.com/industrial</a>
Medical	<a href="http://www.ti.com/medical">www.ti.com/medical</a>
Security	<a href="http://www.ti.com/security">www.ti.com/security</a>
Space, Avionics and Defense	<a href="http://www.ti.com/space-avionics-defense">www.ti.com/space-avionics-defense</a>
Transportation and Automotive	<a href="http://www.ti.com/automotive">www.ti.com/automotive</a>
Video and Imaging	<a href="http://www.ti.com/video">www.ti.com/video</a>

TI E2E Community Home Page

[e2e.ti.com](http://e2e.ti.com)

Mailing Address: Texas Instruments, Post Office Box 655303, Dallas, Texas 75265  
Copyright © 2011, Texas Instruments Incorporated