

TVS Diodes

Transient Voltage Suppressor Diodes

ESD0P2RF Series

Bi-directional Ultra-low Capacitance ESD / Transient Protection Diode

ESD0P2RF-02LS
ESD0P2RF-02LRH

Data Sheet

Rev. 1.2, 2012-10-01
Final

Edition 2012-10-01

**Published by
Infineon Technologies AG
81726 Munich, Germany**

**© 2012 Infineon Technologies AG
All Rights Reserved.**

Legal Disclaimer

The information given in this document shall in no event be regarded as a guarantee of conditions or characteristics. With respect to any examples or hints given herein, any typical values stated herein and/or any information regarding the application of the device, Infineon Technologies hereby disclaims any and all warranties and liabilities of any kind, including without limitation, warranties of non-infringement of intellectual property rights of any third party.

Information

For further information on technology, delivery terms and conditions and prices, please contact the nearest Infineon Technologies Office (www.infineon.com).

Warnings

Due to technical requirements, components may contain dangerous substances. For information on the types in question, please contact the nearest Infineon Technologies Office.

Infineon Technologies components may be used in life-support devices or systems only with the express written approval of Infineon Technologies, if a failure of such components can reasonably be expected to cause the failure of that life-support device or system or to affect the safety or effectiveness of that device or system. Life support devices or systems are intended to be implanted in the human body or to support and/or maintain and sustain and/or protect human life. If they fail, it is reasonable to assume that the health of the user or other persons may be endangered.

Revision History: Rev. 1.1, 2012-04-27

Page or Item	Subjects (major changes since previous revision)
Rev. 1.2, 2012-10-01 Page Nr.8 Package name corrected (mismatch)	
10	Table 2-4 updated

Trademarks of Infineon Technologies AG

AURIX™, BlueMoon™, C166™, CanPAK™, CIPOS™, CIPURSE™, COMNEON™, EconoPACK™, CoolMOS™, CoolSET™, CORECONTROL™, CROSSAVE™, DAVE™, EasyPIM™, EconoBRIDGE™, EconoDUAL™, EconoPIM™, EiceDRIVER™, eupec™, FCOS™, HITFET™, HybridPACK™, I²RF™, ISOFACE™, IsoPACK™, MIPAQ™, ModSTACK™, my-d™, NovalithIC™, OmniTune™, OptiMOS™, ORIGA™, PRIMARION™, PrimePACK™, PrimeSTACK™, PRO-SIL™, PROFET™, RASIC™, ReverSave™, SatRIC™, SIEGET™, SINDRION™, SIPMOS™, SMARTi™, SmartLEWIS™, SOLID FLASH™, TEMPFET™, thinQ!™, TRENCHSTOP™, TriCore™, X-GOLD™, X-PMU™, XMM™, XPOSYS™.

Other Trademarks

Advance Design System™ (ADS) of Agilent Technologies, AMBA™, ARM™, MULTI-ICE™, KEIL™, PRIMECELL™, REALVIEW™, THUMB™, μVision™ of ARM Limited, UK. AUTOSAR™ is licensed by AUTOSAR development partnership. Bluetooth™ of Bluetooth SIG Inc. CAT-ig™ of DECT Forum. COLOSSUS™, FirstGPS™ of Trimble Navigation Ltd. EMV™ of EMVCo, LLC (Visa Holdings Inc.). EPCOS™ of Epcos AG. FLEXGO™ of Microsoft Corporation. FlexRay™ is licensed by FlexRay Consortium. HYPERTERMINAL™ of Hilgraeve Incorporated. IEC™ of Commission Electrotechnique Internationale. IrDA™ of Infrared Data Association Corporation. ISO™ of INTERNATIONAL ORGANIZATION FOR STANDARDIZATION. MATLAB™ of MathWorks, Inc. MAXIM™ of Maxim Integrated Products, Inc. MICROTEC™, NUCLEUS™ of Mentor Graphics Corporation. Mifare™ of NXP. MIPI™ of MIPI Alliance, Inc. MIPS™ of MIPS Technologies, Inc., USA. muRata™ of MURATA MANUFACTURING CO., MICROWAVE OFFICE™ (MWO) of Applied Wave Research Inc., OmniVision™ of OmniVision Technologies, Inc. Openwave™ Openwave Systems Inc. RED HAT™ Red Hat, Inc. RFMD™ RF Micro Devices, Inc. SIRIUS™ of Sirius Satellite Radio Inc. SOLARIS™ of Sun Microsystems, Inc. SPANSION™ of Spansion LLC Ltd. Symbian™ of Symbian Software Limited. TAIYO YUDEN™ of Taiyo Yuden Co. TEAKLITE™ of CEVA, Inc. TEKTRONIX™ of Tektronix Inc. TOKO™ of TOKO KABUSHIKI KAISHA TA. UNIX™ of X/Open Company Limited. VERILOG™, PALLADIUM™ of Cadence Design Systems, Inc. VLYNQ™ of Texas Instruments Incorporated. VXWORKS™, WIND RIVER™ of WIND RIVER SYSTEMS, INC. ZETEX™ of Diodes Zetex Limited.

Last Trademarks Update 2010-10-26

1 Bi-directional Ultra-low Capacitance ESD / Transient Protection Diode

1.1 Features

- ESD / transient protection of RF signal lines according to:
 - IEC61000-4-2 (ESD): ± 20 kV (air/contact)
 - IEC61000-4-4 (EFT): 40 A (5/50 ns)
 - IEC61000-4-5 (surge): 3 A (8/20 μ s)
- Maximum working voltage: $V_{RWM} \pm 5.3$ V
- Extremely low capacitance: $C_L = 0.2$ pF (typical)
- Low clamping voltage: $V_{CL} = 29$ V at $I_{PP} = 16$ A (typical)
- Very low reverse current $I_R < 1$ nA typ.
- Very small form factor down to 0.62 x 0.32 x 0.31 mm³
- Pb-free (RoHS compliant) and halogen free package



1.2 Application Examples

- ESD protection of sensitive RF signal lines, Bluetooth Class 2, Automated Meter Reading
- RF antenna protection, frontend module, GPS, mobile TV, FM radio, UWB

1.3 Product Description

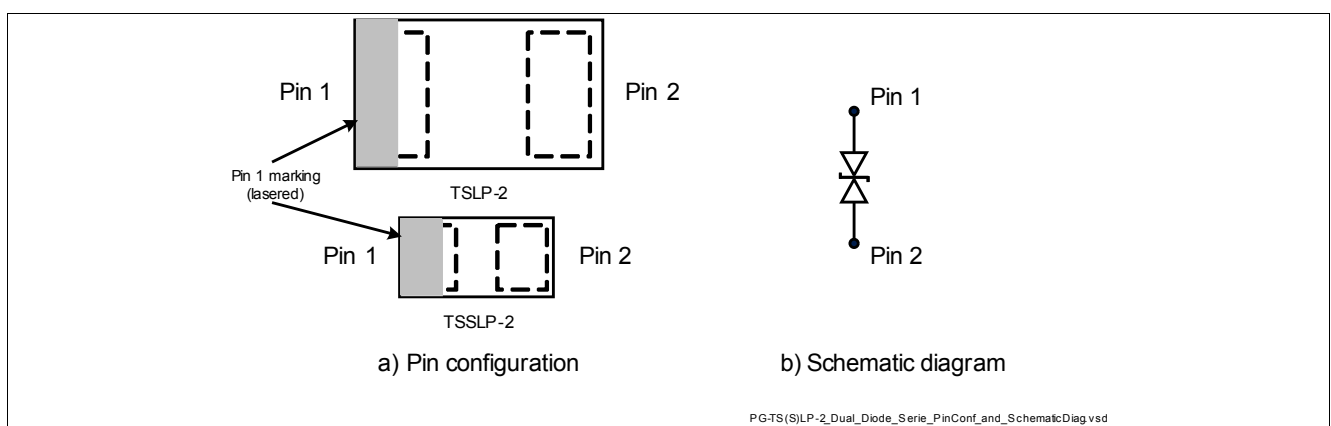

Figure 1-1 Pin Configuration and Schematic Diagram

Table 1-1 Ordering Information

Type	Package	Configuration	Marking code
ESD0P2RF-02LS	PG-TSSLP-2-1	1 line, bi-directional	T
ESD0P2RF-02LRH	PG-TSLP-2-17	1 line, bi-directional	T

2 Characteristics

Table 2-1 Maximum Ratings at $T_A = 25\text{ }^\circ\text{C}$, unless otherwise specified

Parameter	Symbol	Values			Unit
		Min.	Typ.	Max.	
ESD air / contact discharge ¹⁾	V_{ESD}	–	–	20	kV
Peak pulse current ($t_p = 8/20\text{ }\mu\text{s}$) ²⁾	I_{PP}	–	–	3	A
Operating temperature range	T_{OP}	-55	–	125	$^\circ\text{C}$
Storage temperature	T_{stg}	-65	–	150	$^\circ\text{C}$

1) V_{ESD} according to IEC61000-4-2

2) I_{PP} according to IEC61000-4-5

Attention: Stresses above the max. values listed here may cause permanent damage to the device. Exposure to absolute maximum rating conditions for extended periods may affect device reliability. Maximum ratings are absolute ratings; exceeding only one of these values may cause irreversible damage to the integrated circuit.

2.1 Electrical Characteristics at $T_A=25\text{ }^\circ\text{C}$, unless otherwise specified

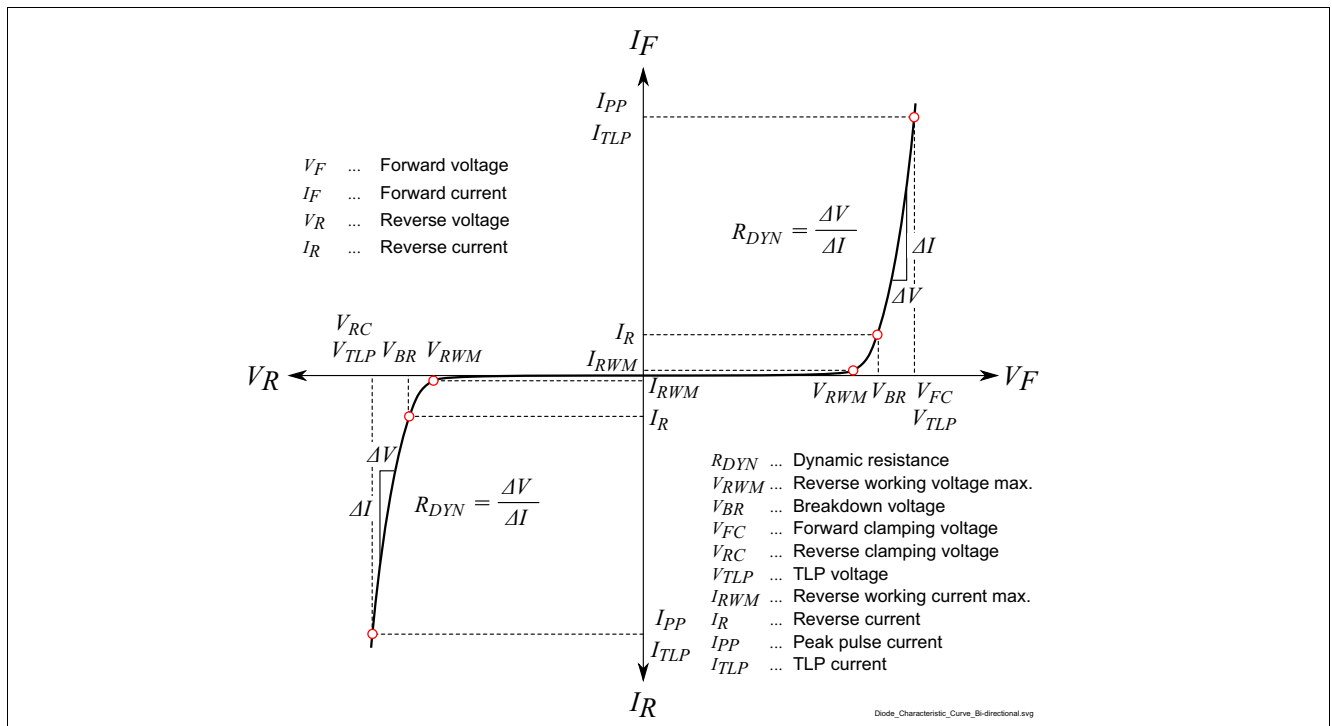

Figure 2-1 Definitions of electrical characteristics

Characteristics
Table 2-2 DC Characteristics at $T_A = 25\text{ }^\circ\text{C}$, unless otherwise specified

Parameter	Symbol	Values			Unit	Note / Test Condition
		Min.	Typ.	Max.		
Reverse working voltage	V_{RWM}	-5.3	-	5.3	V	
Breakdown voltage	V_{BR}	7	-	-	V	$I_R = 1\text{ mA}$, from pin 1 to pin 2, from pin 2 to pin 1
Reverse current	I_R	-	<1	50	nA	$V_R = 5.3\text{ V}$

Table 2-3 RF Characteristics at $T_A = 25\text{ }^\circ\text{C}$, unless otherwise specified

Parameter	Symbol	Values			Unit	Note / Test Condition
		Min.	Typ.	Max.		
Diode capacitance	C_L	-	0.23	0.4	pF	$V_R = 0\text{ V}, f = 1\text{ MHz}$
		-	0.2	0.4	pF	$V_R = 0\text{ V}, f = 1\text{ GHz}$

Table 2-4 ESD Characteristics at $T_A = 25\text{ }^\circ\text{C}$, unless otherwise specified

Parameter	Symbol	Values			Unit	Note / Test Condition
		Min.	Typ.	Max.		
Clamping voltage ²⁾	V_{CL}	-	29	-	V	$I_{TLP} = 16\text{ A}$
		-	38	-		$I_{TLP} = 30\text{ A}$
Clamping voltage ¹⁾		-	11	17		$I_{PP} = 1\text{ A}$
		-	15	21		$I_{PP} = 3\text{ A}$
Dynamic resistance ²⁾	R_{DYN}	-	1	-	Ω	
Series inductance	L_S	-	0.2	-	nH	ESD0P2RF-02LS
		-	0.4	-	nH	ESD0P2RF-02LRH

1) I_{PP} according to IEC61000-4-5 ($t_p = 8/20\text{ }\mu\text{s}$)

2) Please refer to Application Note AN210 [4]. TLP parameter: $Z_0 = 50\text{ }\Omega$, $t_p = 100\text{ ns}$, $t_r = 300\text{ ps}$, averaging window: $t_1 = 30\text{ ns}$ to $t_2 = 60\text{ ns}$, extraction of dynamic resistance using least squares fit of TLP characteristics between $I_{TLP1} = 10\text{ A}$ and $I_{TLP2} = 40\text{ A}$.

2.2 Typical Characteristics at $T_A = 25\text{ }^\circ\text{C}$, unless otherwise specified

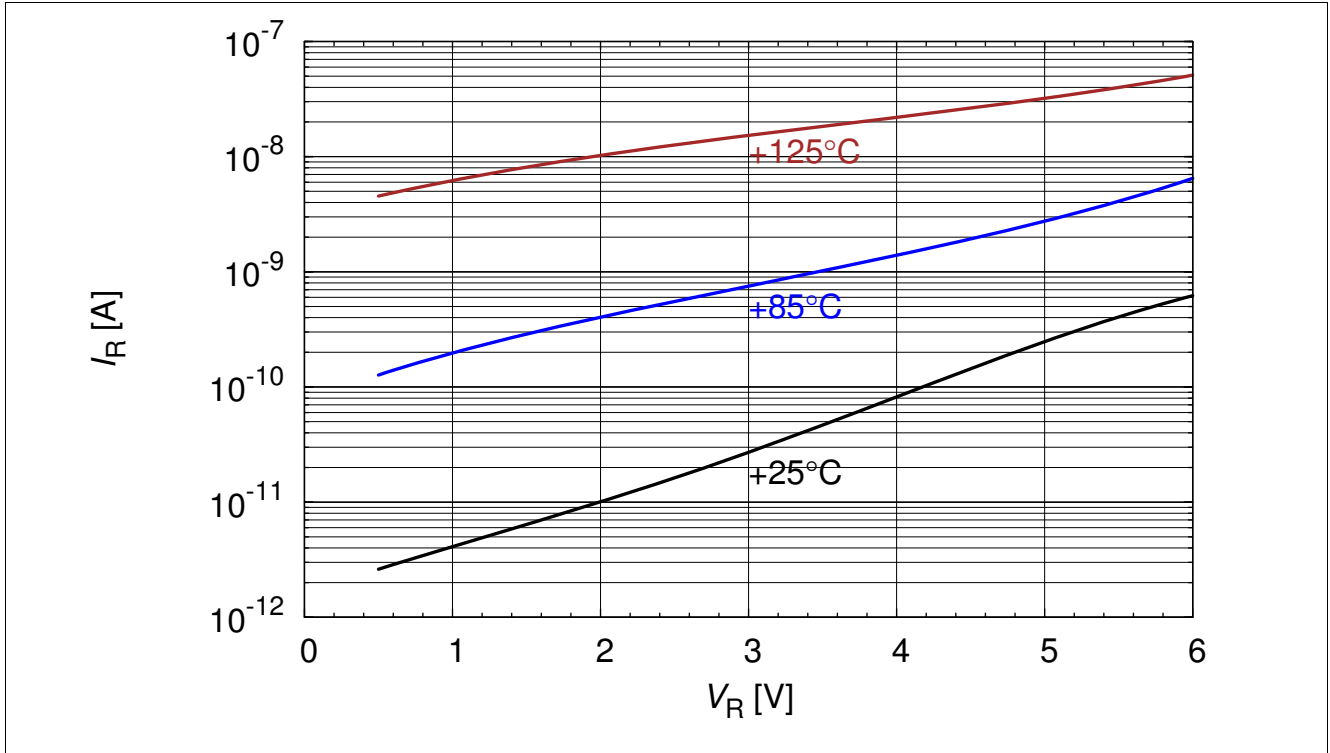

Figure 2-2 Reverse current: $I_R = f(V_R)$, $T_A = \text{parameter}$

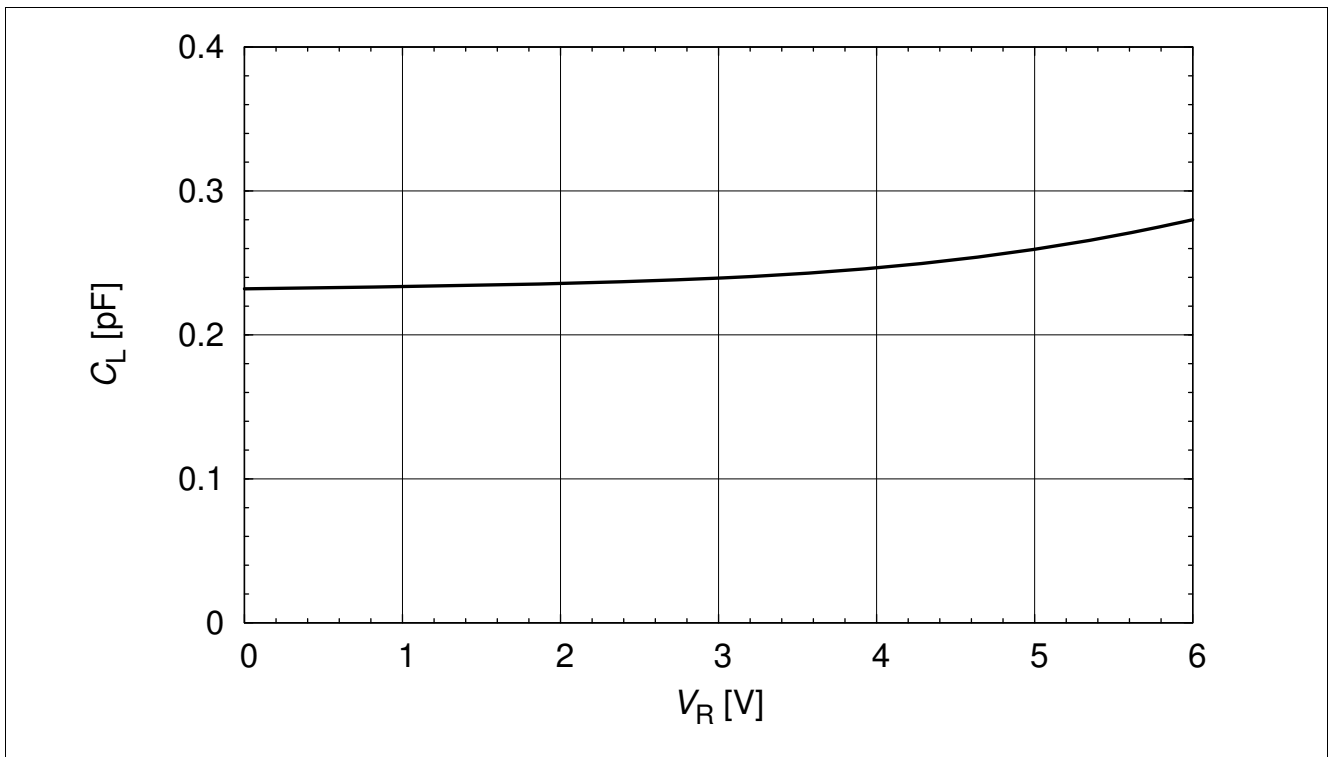

Figure 2-3 Line capacitance: $C_L = f(V_R)$, $f = 1\text{ MHz}$

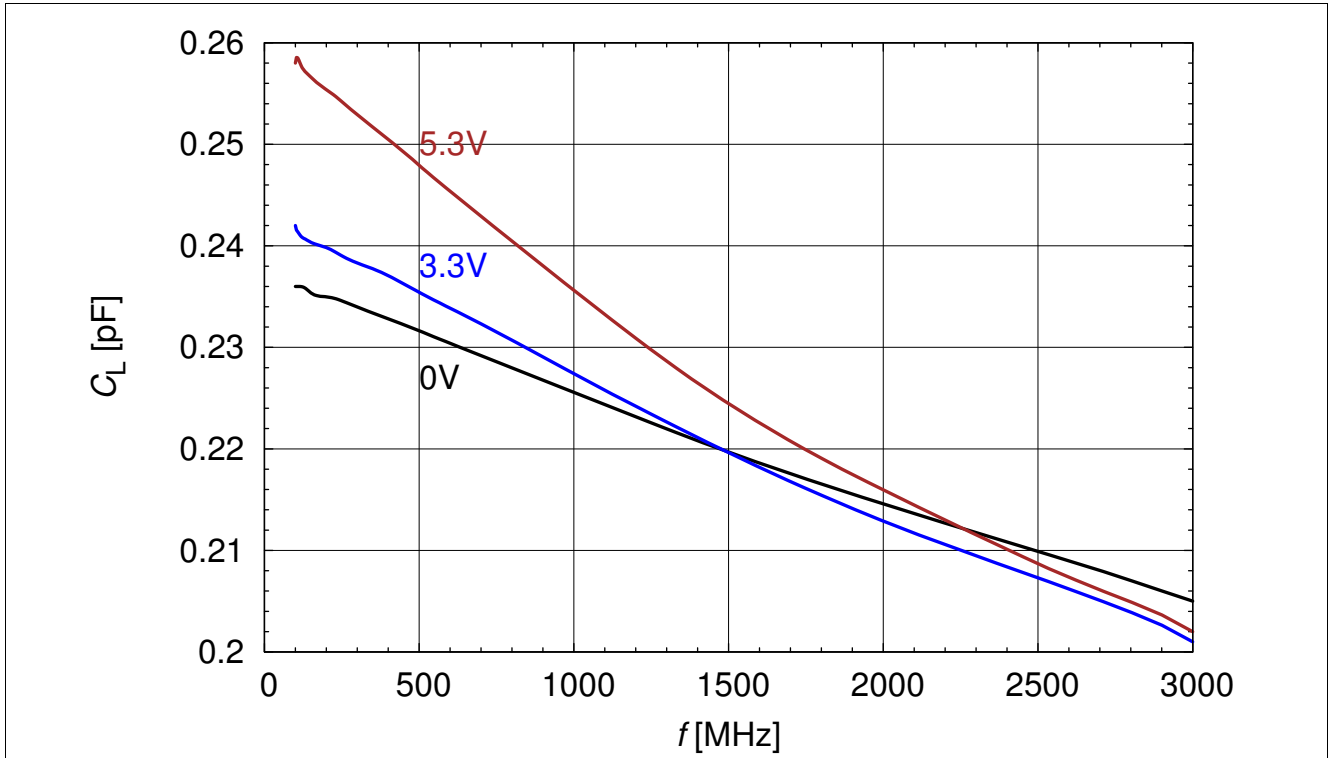

Figure 2-4 Line capacitance: $C_L = f(f)$, $V_R = \text{parameter}$

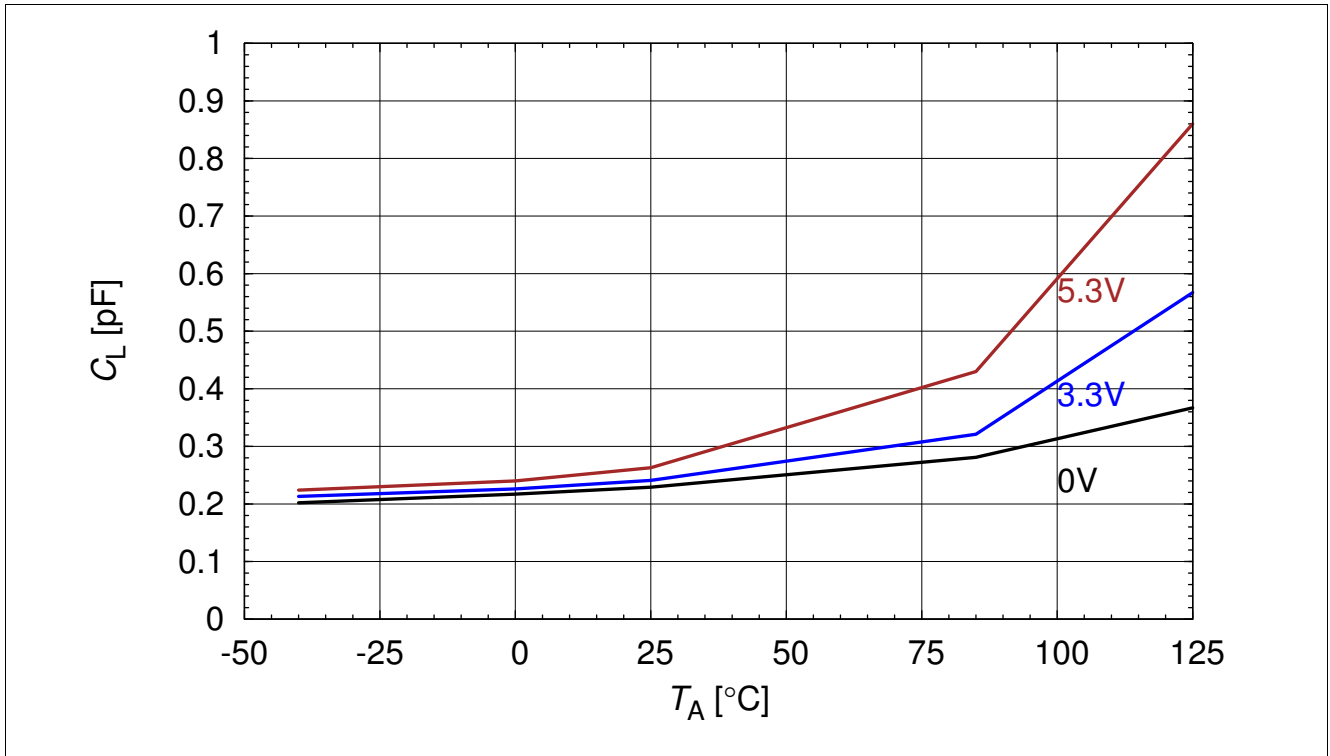

Figure 2-5 Line capacitance: $C_L = f(T_A)$, $V_R = \text{parameter}$

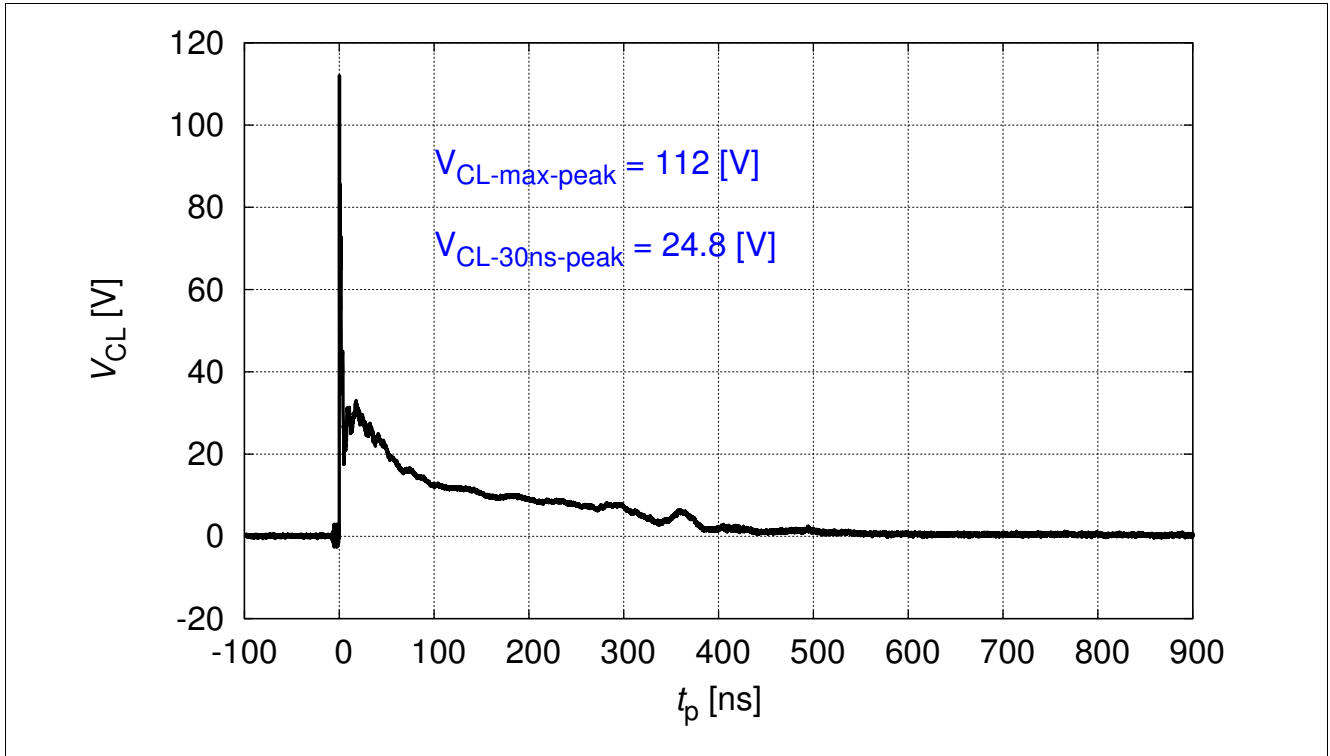

Figure 2-6 IEC61000-4-2 $V_{CL} = f(t)$, 8 kV positiv pulse from pin 1 to pin 2

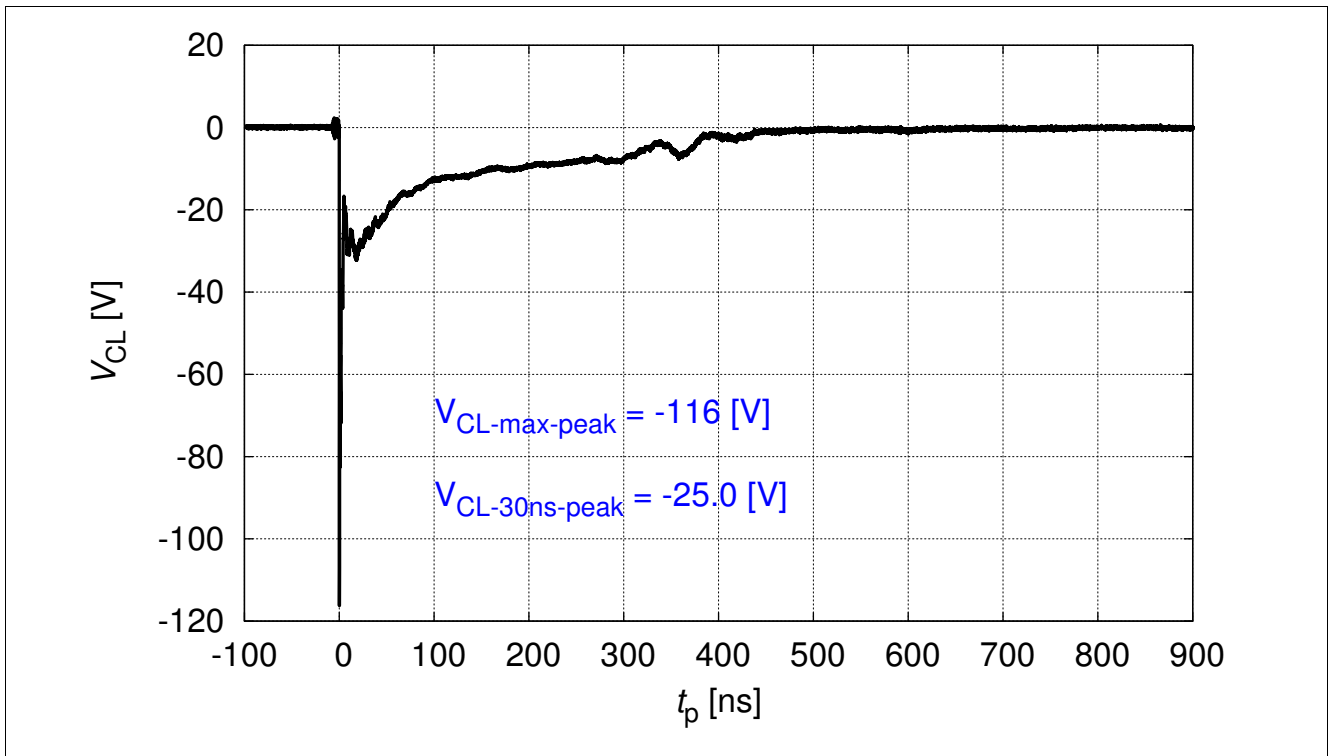

Figure 2-7 IEC61000-4-2 $V_{CL} = f(t)$, 8 kV negativ pulse from pin 1 to pin 2

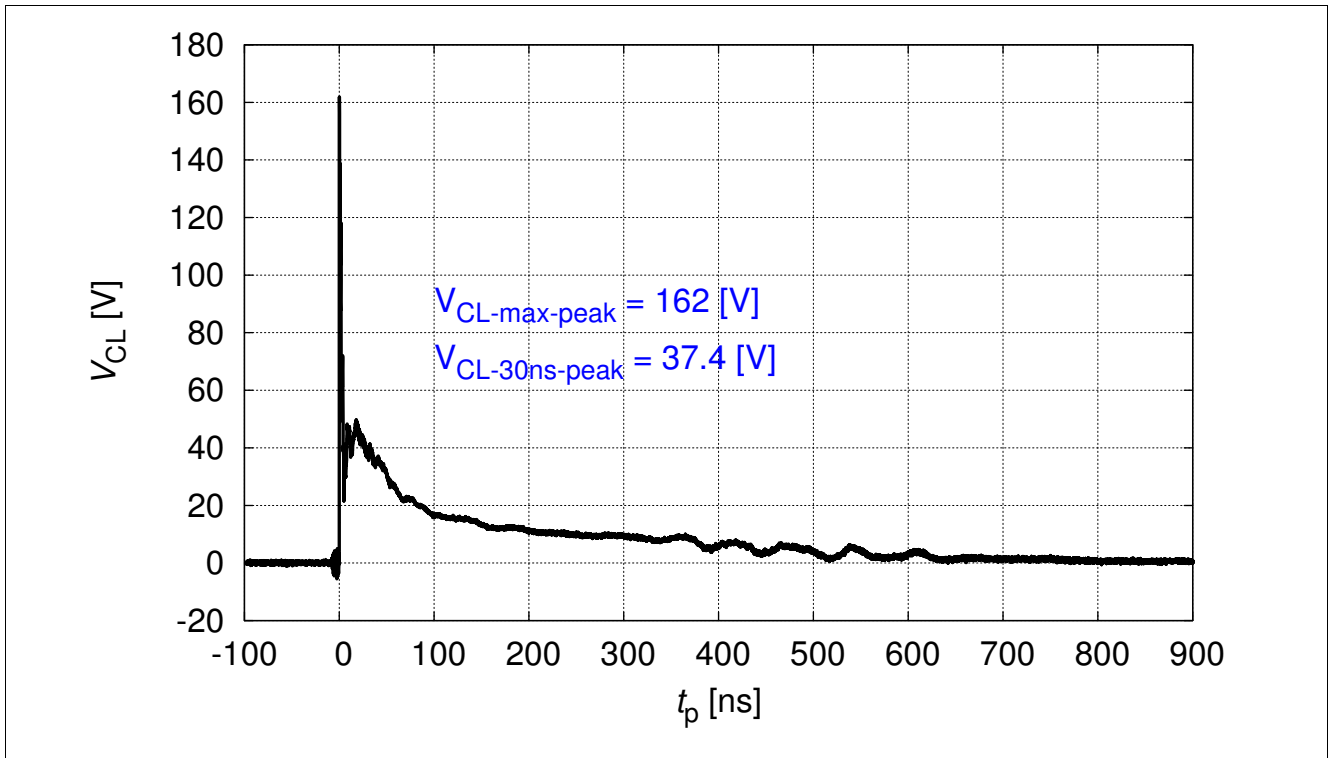

Figure 2-8 IEC61000-4-2 $V_{CL} = f(t)$, 15 kV positiv pulse from pin 1 to pin 2

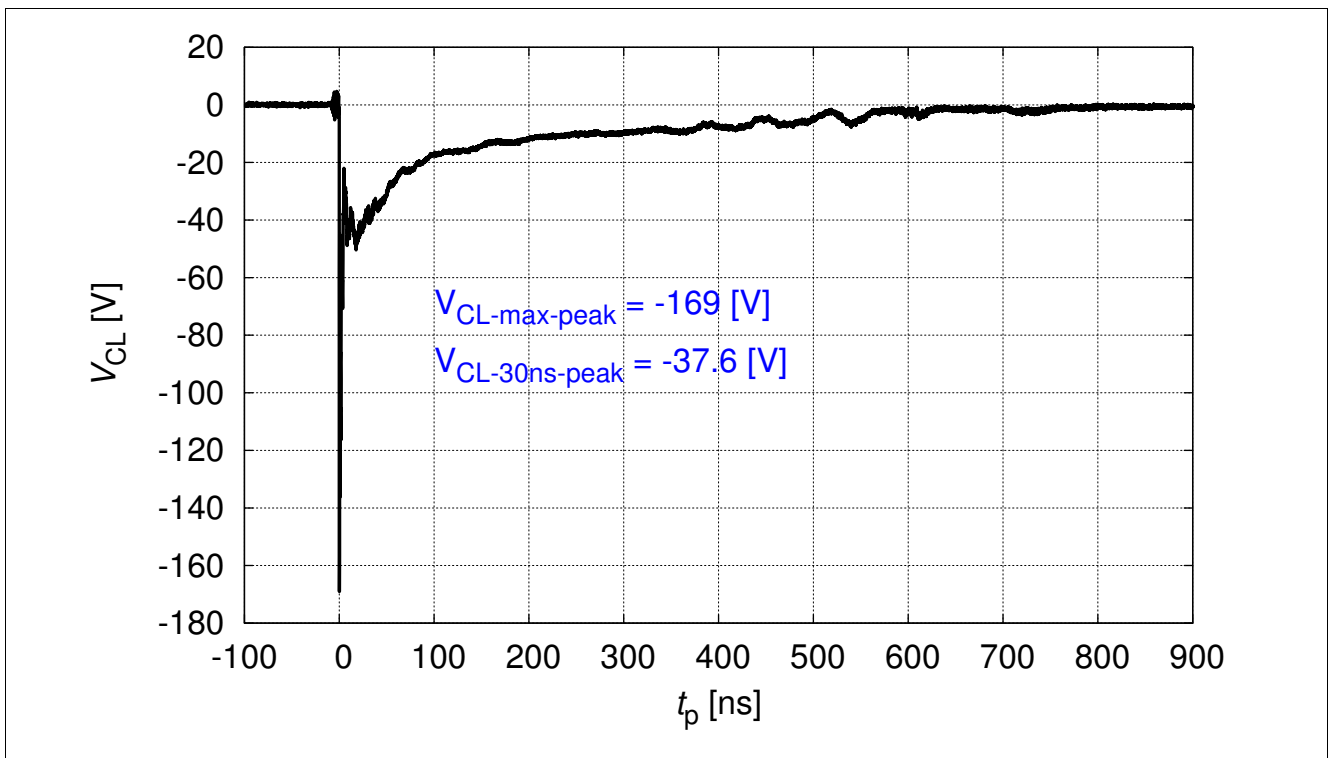

Figure 2-9 IEC61000-4-2 $V_{CL} = f(t)$, 15 kV negativ pulse from pin 1 to pin 2

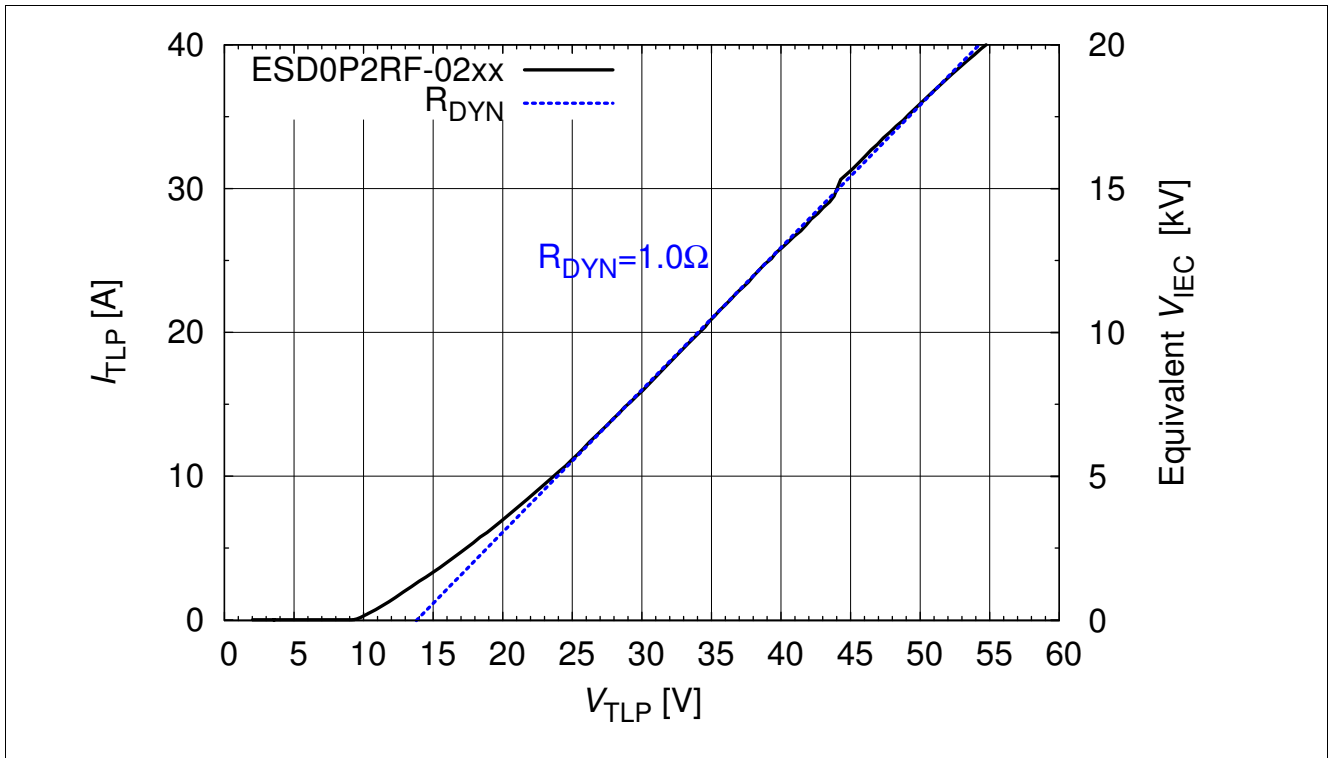

Figure 2-10 Clamping voltage : $I_{TLP} = f(V_{TLP})$ [4]

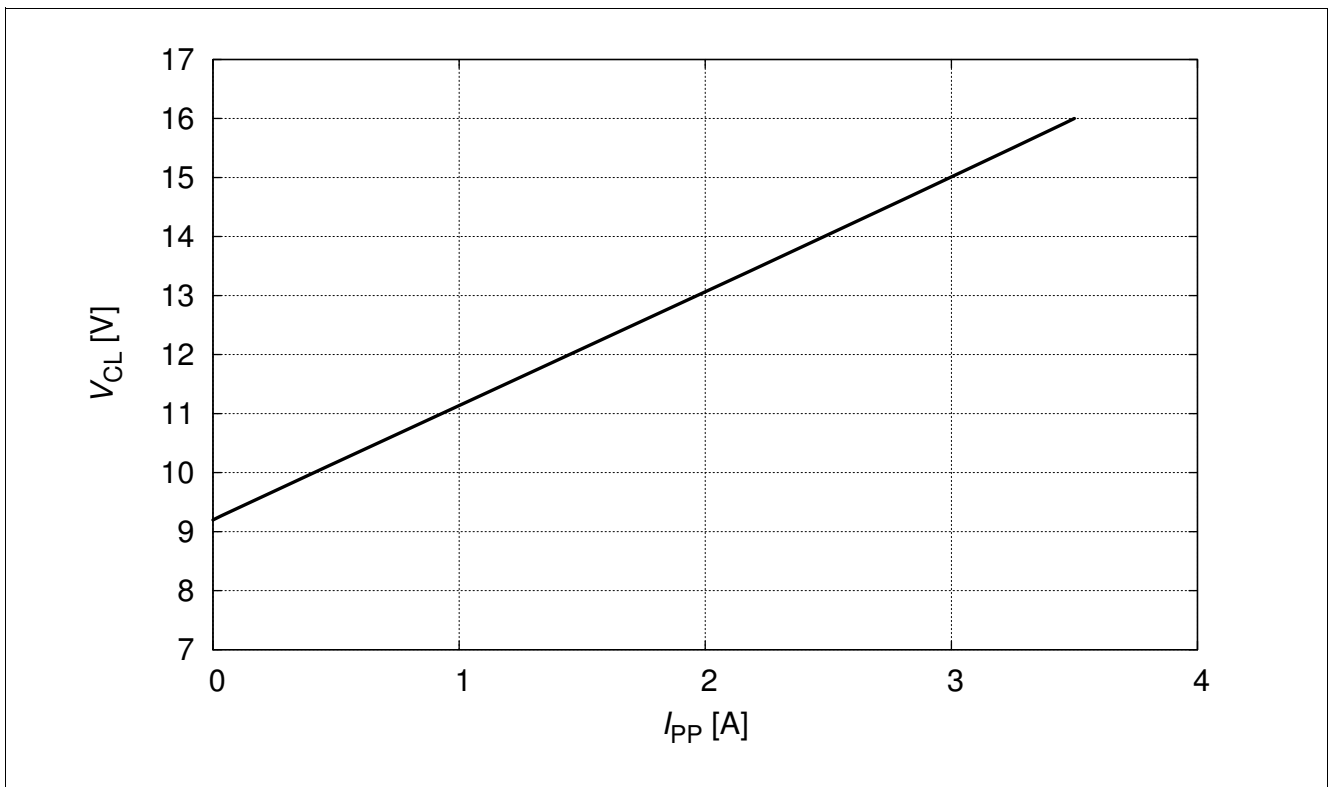

Figure 2-11 Clamp voltage: $V_{CL} = f(I_{PP})$, $t_p = 8/20 \mu s$

3 Application Information

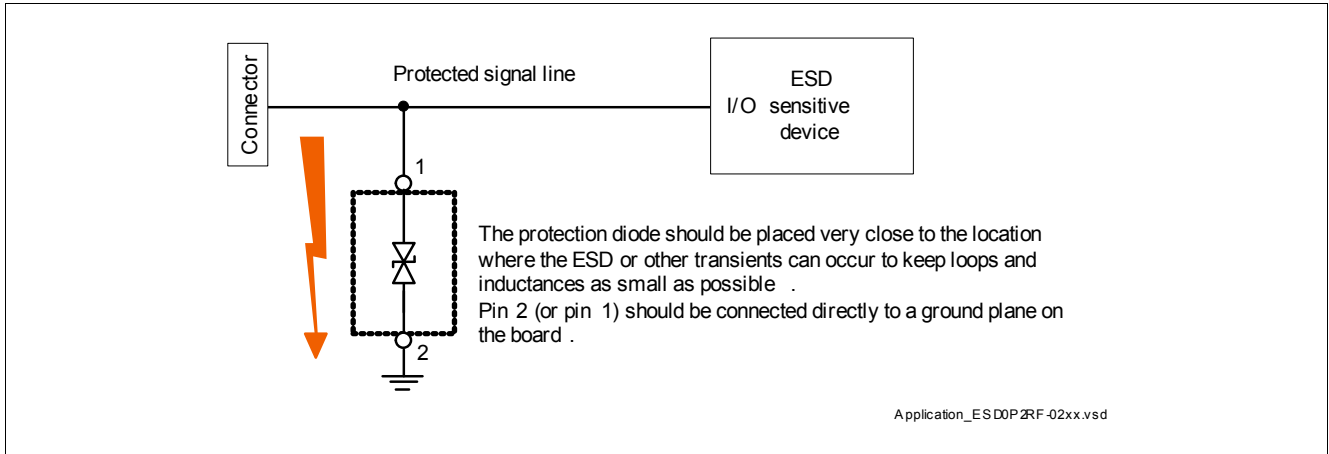

Figure 3-1 Single line, bi-directional ESD / Transient protection [1], [2]

4 Ordering Information Scheme (Examples)

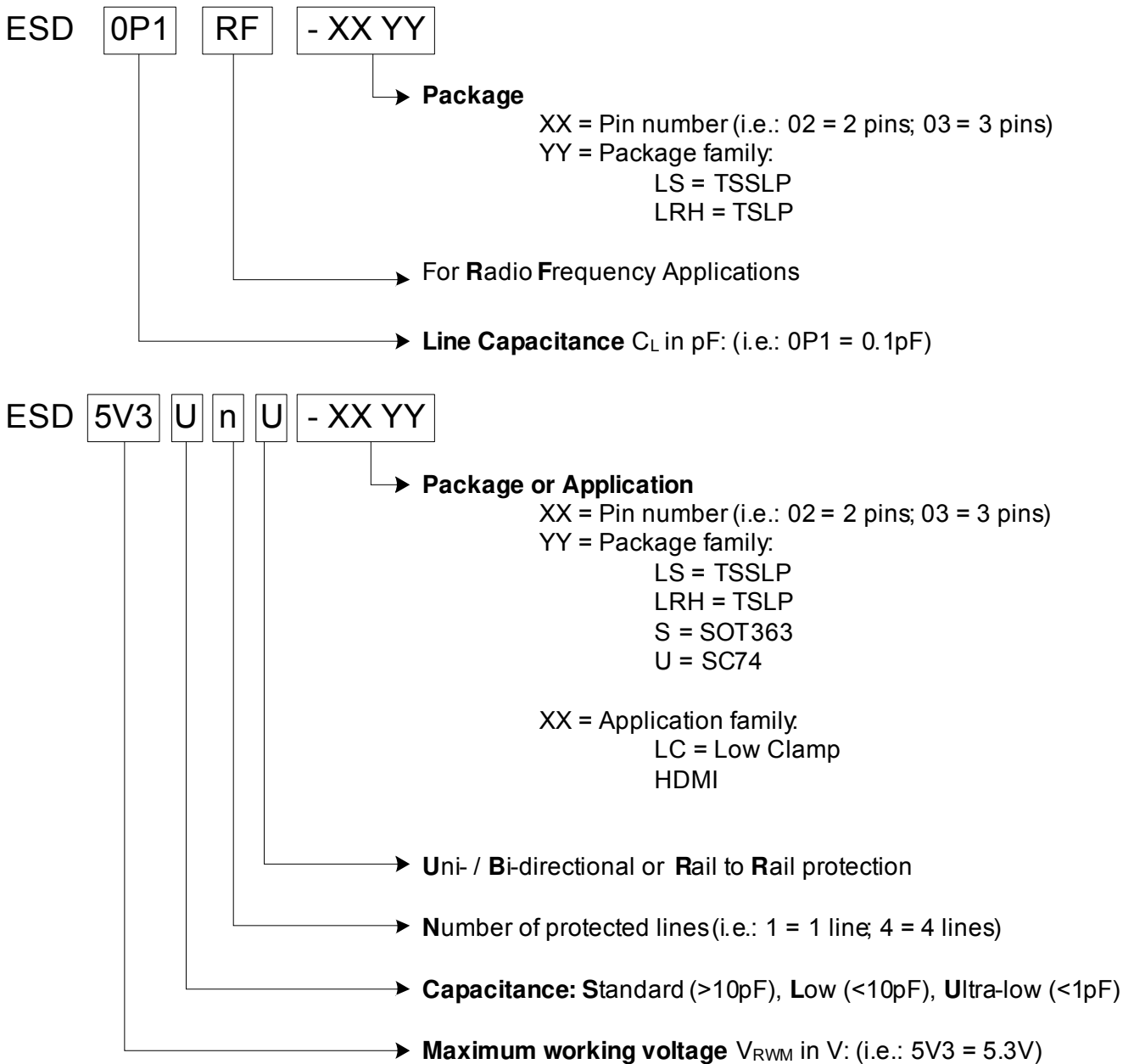

Figure 4-1 Ordering information scheme

5 Package Information

5.1 PG-TSLP-2-17 (mm) [5]

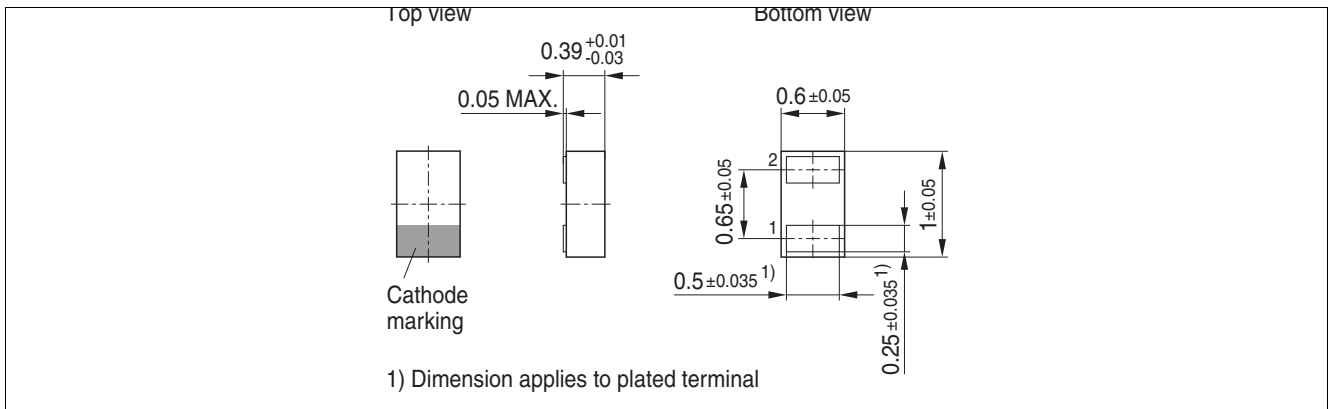

Figure 5-1 PG-TSLP-2-17: Package overview

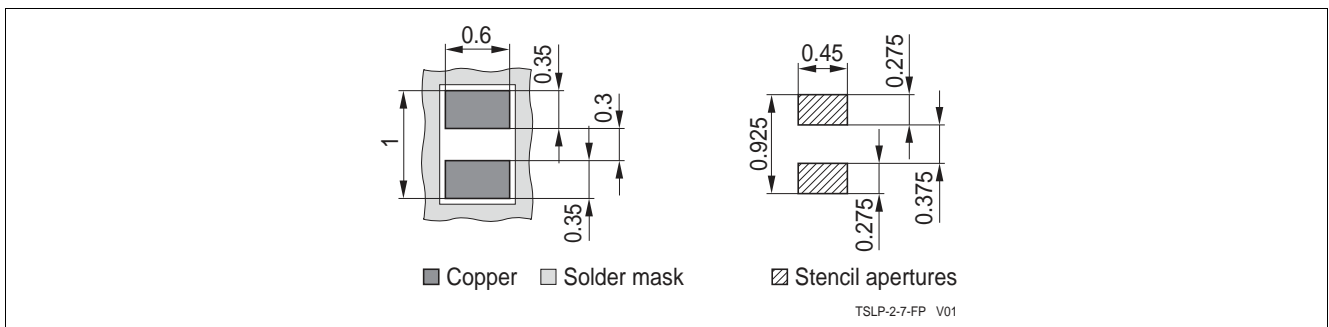

Figure 5-2 PG-TSLP-2-17: Footprint

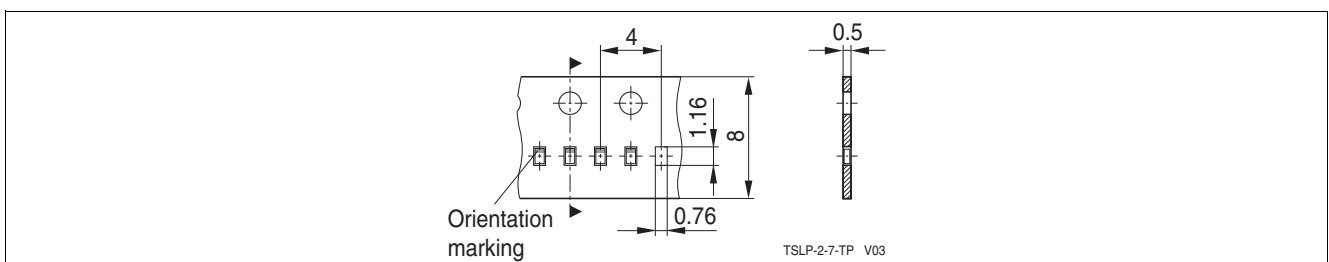

Figure 5-3 PG-TSLP-2-17: Packing

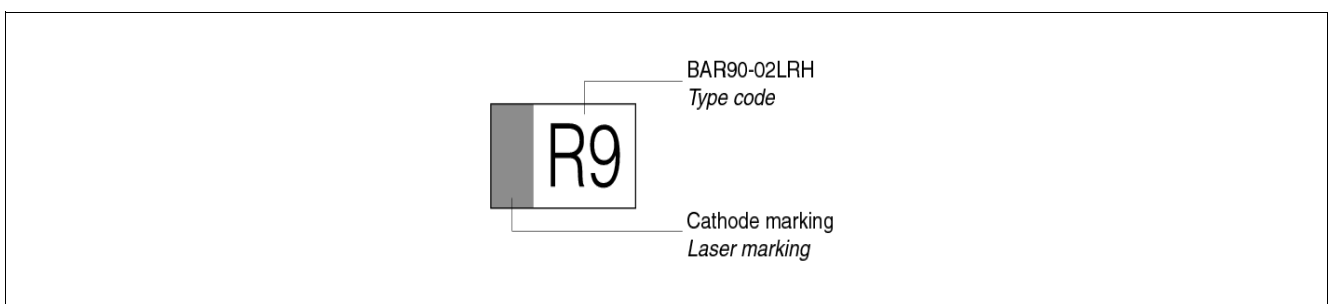

Figure 5-4 PG-TSLP-2-17: Marking (example)

6 Package Information

6.1 PG-TSSLP-2-1 (mm) [5]

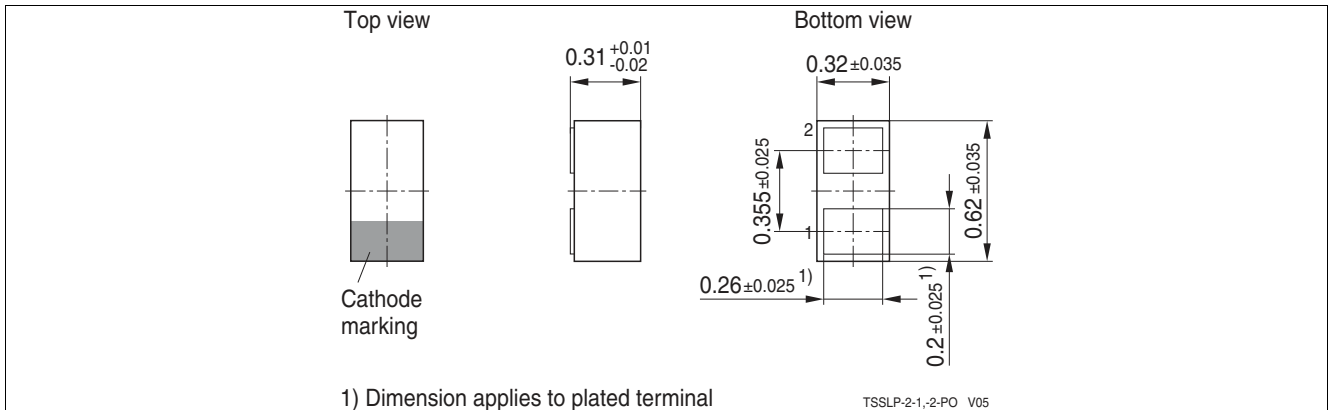

Figure 6-1 PG-TSSLP-2-1: Package overview

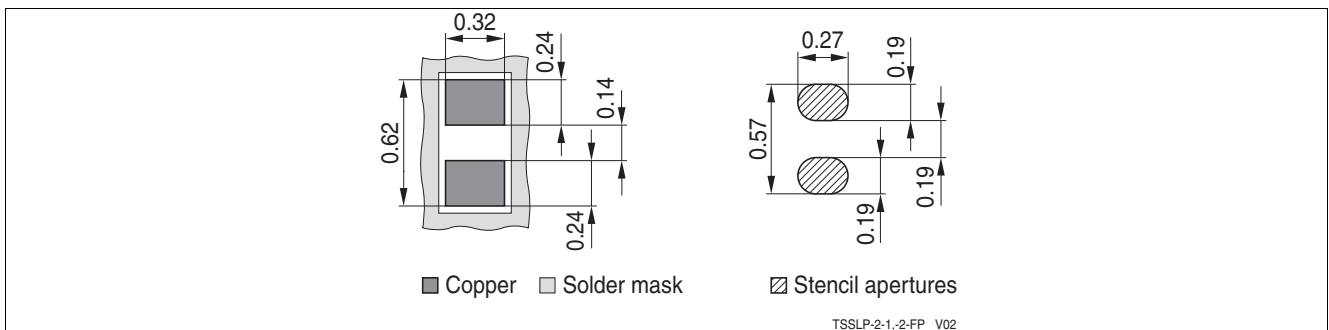

Figure 6-2 PG-TSSLP-2-1: Footprint

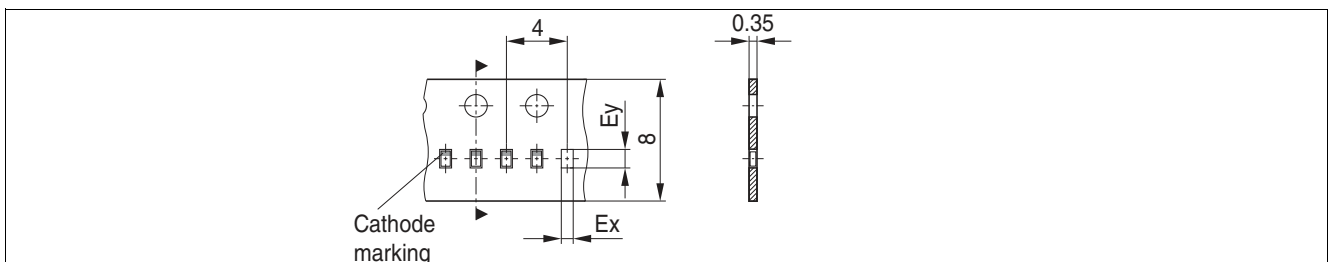

Figure 6-3 PG-TSSLP-2-1: Packing

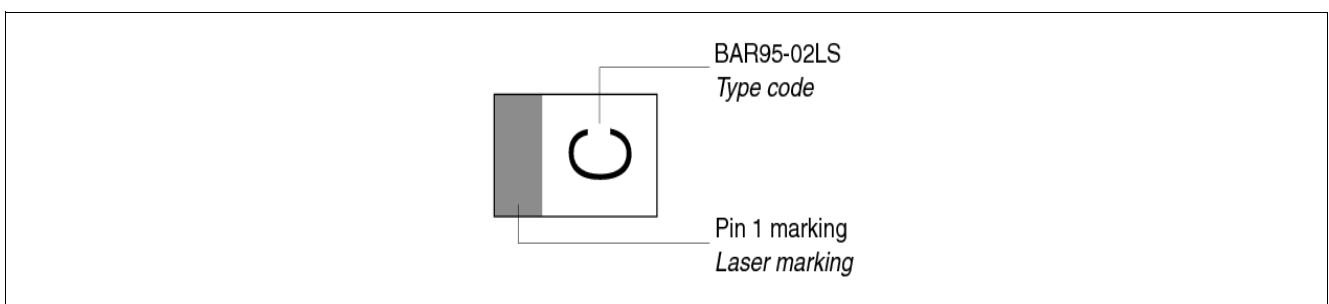

Figure 6-4 PG-TSSLP-2-1: Marking (example)

References

- [1] Infineon AG - **Application Note AN167**: ESD Protection for Broadband LNA BGA728L7 for Portable and Mobile TV Applications
- [2] Infineon AG - **Application Note AN178**: ESD Protection for RF Antennas using Infineon ESD0P4RFL and ESD0P2RF-xx
- [3] Infineon AG - **Application Note AN200**: Low Cost FM Radio LNA using BFR340F for Mobile Phone Applications
- [4] Infineon AG - **Application Note AN210**: Effective ESD Protection Design at System Level using VF-TLP Characterization Methodology
- [5] Infineon AG - Recommendations for PCB Assembly of Infineon TSLP and TSSLP Packages

www.infineon.com

Published by Infineon Technologies AG