

FEATURES

- Low Input Offset Voltage: 75 μV Max**
- Low Offset Voltage Drift, Over $-55^\circ\text{C} \leq T_A \leq +125^\circ\text{C}$:**
0.5 $\mu\text{V}/^\circ\text{C}$ Max
- Low Supply Current (Per Amplifier): 725 μA Max**
- High Open-Loop Gain: 5000 V/mV Min**
- Low Input Bias Current: 2 nA Max**
- Low Noise Voltage Density: 11 nV/ $\sqrt{\text{Hz}}$ at 1 kHz**
- Stable with Large Capacitive Loads: 10 nF Typ**
- Pin Compatible to OP221, MC1458, and LT1013 with Improved Performance**
- Available in Die Form**

GENERAL DESCRIPTION

The OP200 is the first monolithic dual operational amplifier to offer OP77 type precision performance. Available in the industry-standard 8-lead pinout, the OP200 combines precision performance with the space and cost savings offered by a dual amplifier.

The OP200 features an extremely low input offset voltage of less than 75 μV with a drift below 0.5 $\mu\text{V}/^\circ\text{C}$, guaranteed over the full military temperature range. Open-loop gain of the OP200 exceeds 5,000,000 into a 10 k Ω load; input bias current is under 2 nA; CMR is over 120 dB and PSRR below 1.8 $\mu\text{V}/\text{V}$. On-chip Zener zap trimming is used to achieve the extremely low input offset voltage of the OP200 and eliminates the need for offset pulling.

Power consumption of the OP200 is very low, with each amplifier drawing less than 725 μA of supply current. The total current drawn by the dual OP200 is less than one-half that of a single OP07, yet the OP200 offers significant improvements over this industry-standard op amp. The voltage noise density of the OP200, 11 nV/ $\sqrt{\text{Hz}}$ at 1 kHz, is half that of most competitive devices.

PIN CONNECTIONS

16-Lead SOIC (S-Suffix)

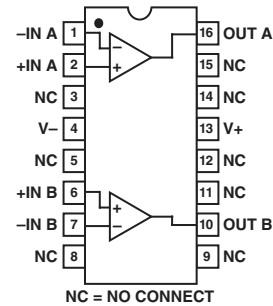

8-Lead PDIP (P-Suffix)

8-Lead CERDIP (Z-Suffix)

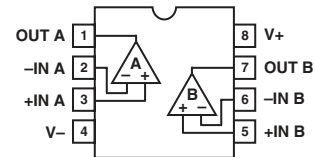

The OP200 is pin compatible with the OP221, LM158, MC1458/1558, and LT1013.

The OP200 is an ideal choice for applications requiring multiple precision op amps and where low power consumption is critical.

For a quad precision op amp, see the OP400.

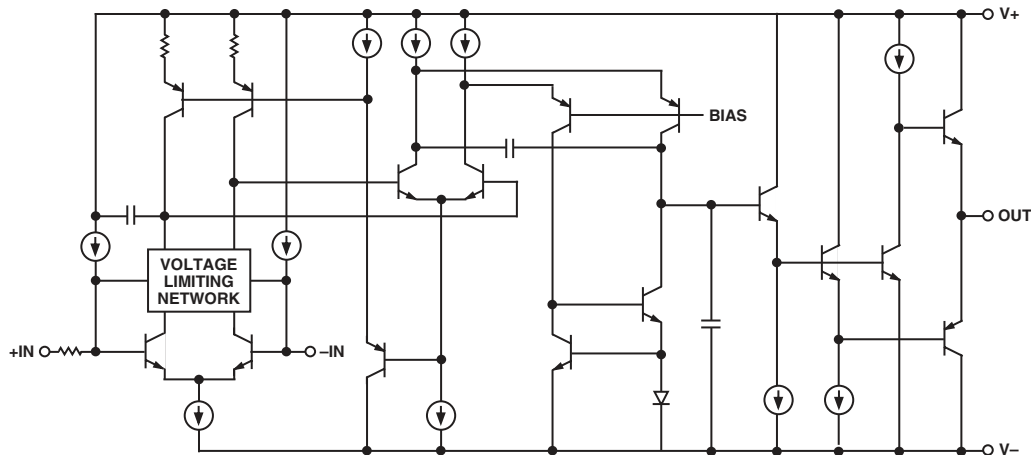

Figure 1. Simplified Schematic (One of two amplifiers is shown.)

REV. B

Information furnished by Analog Devices is believed to be accurate and reliable. However, no responsibility is assumed by Analog Devices for its use, nor for any infringements of patents or other rights of third parties that may result from its use. No license is granted by implication or otherwise under any patent or patent rights of Analog Devices. Trademarks and registered trademarks are the property of their respective owners.

OP200—SPECIFICATIONS

ELECTRICAL CHARACTERISTICS ($V_S = \pm 15\text{ V}$, $T_A = 25^\circ\text{C}$, unless otherwise noted.)

Parameter	Symbol	Conditions	OP200A/E			OP200G			Unit
			Min	Typ	Max	Min	Typ	Max	
Input Offset Voltage	V_{OS}			25	75		80	200	μV
Long-Term Input Voltage Stability				0.1			0.1		$\mu\text{V}/\text{mo}$
Input Offset Current	I_{OS}	$V_{CM} = 0\text{ V}$		0.05	1.0		0.05	3.5	nA
Input Bias Current	I_B	$V_{CM} = 0\text{ V}$		0.1	2.0		0.1	5.0	nA
Input Noise Voltage	$e_{n\text{ p-p}}$	0.1 Hz to 10 Hz		0.5			0.5		$\mu\text{V}_{\text{p-p}}$
Input Noise Voltage Density*	e_n	$f_O = 10\text{ Hz}$ $f_O = 1000\text{ Hz}$		22 11	36 18		22 11		$\text{nV}/\sqrt{\text{Hz}}$
Input Noise Current	$i_{n\text{ p-p}}$	0.1 Hz to 10 Hz		15			15		$\text{pA}_{\text{p-p}}$
Input Noise Current Density	i_n	$f_O = 10\text{ Hz}$		0.4			0.4		$\text{pA}/\sqrt{\text{Hz}}$
Input Resistance Differential Mode	R_{IN}			10			10		$\text{M}\Omega$
Input Resistance Common Mode	R_{INCM}			125			125		$\text{G}\Omega$
Large Signal Voltage Gain	A_{VO}	$V_O = \pm 10\text{ V}$ $R_L = 10\text{ k}\Omega$ $R_L = 2\text{ k}\Omega$	5000 2000	12000 3700		3000 1500	7000 3200		M/mV

*Sample tested.

Specifications subject to change without notice.

ELECTRICAL CHARACTERISTICS ($V_S = 15\text{ V}$, $-55^\circ\text{C} \leq T_A \leq +125^\circ\text{C}$ for OP200A, unless otherwise noted.)

Parameter	Symbol	Conditions	OP200A			Unit
			Min	Typ	Max	
Input Offset Voltage	V_{OS}			45	125	μV
Average Input Offset Voltage Drift	TCV_{OS}			0.2	0.5	$\mu\text{V}/^\circ\text{C}$
Input Offset Current	I_{OS}	$V_{CM} = 0\text{ V}$		0.15	2.5	nA
Input Bias Current	I_B	$V_{CM} = 0\text{ V}$		0.9	5.0	nA
Large Signal Voltage Gain	A_{VO}	$V_O = 10\text{ V}$ $R_L = 10\ \Omega$ $R_L = 2\text{ k}\Omega$	3000 1000	9000 2700		V/mV V/mV
Input Voltage Range*	IVR		± 12	± 12.5		V
Common-Mode Rejection	CMR	$V_{CM} = \pm 12\text{ V}$	115	130		dB
Power Supply Rejection Ratio	PSRR	$V_S = +3\text{ V to } +18\text{ V}$		0.2	3.2	$\mu\text{V}/\text{V}$
Output Voltage Swing	V_O	$R_L = 10\text{ k}\Omega$ $R_L = 2\text{ k}\Omega$	± 12 ± 11	± 12.4 ± 12		V V
Supply Current Per Amplifier	I_{SY}	No Load		600	775	μA
Capacitive Load Stability		$A_V = 1$		8		nF

*Guaranteed by CMR test.

Specifications subject to change without notice.

ELECTRICAL CHARACTERISTICS ($V_S = \pm 15\text{ V}$, $T_A = 25^\circ\text{C}$, unless otherwise noted.)

Parameter	Symbol	Conditions	OP200A/E			OP200G			Unit
			Min	Typ	Max	Min	Typ	Max	
Input Voltage Range ¹	IVR		± 12	± 13		± 12	± 13		V
Common-Mode Rejection	CMR	$V_{CM} = \pm 12\text{ V}$	120	135		110	130		dB
Power Supply Rejection Ratio	PSRR	$V_S = \pm 3\text{ V to } \pm 18\text{ V}$		0.4	1.8		0.6	5.6	$\mu\text{V}/\text{V}$
Output Voltage Swing	V_O	$R_L = 10\text{ k}\Omega$ $R_L = 2\text{ k}\Omega$	± 12 ± 11	± 12.6 ± 12.2		± 12 ± 11	± 12.6 ± 12.2		V V
Supply Current Per Amplifier	I_{SY}	No Load		570	725		570	725	μA
Slew Rate	SR		0.1	0.15		0.1	0.15		V/ μS
Gain Bandwidth Product	GBWP	$A_V = 1$		500			500		kHz
Channel Separation ²	CS	$V_O = 20\text{ V p-p}$ $f_O = 10\text{ Hz}$	123	145		123	145		dB
Input Capacitance	C_{IN}			3.2			3.2		pF
Capacitive Load Stability		$A_V = 1$ No Oscillations		10			10		nF

NOTES

¹Guaranteed by CMR test.

²Guaranteed but not 100% tested.

Specifications subject to change without notice.

OP200—SPECIFICATIONS

ELECTRICAL CHARACTERISTICS ($V_S = \pm 15\text{ V}$, $-40^\circ\text{C} \leq T_A \leq +85^\circ\text{C}$, unless otherwise noted.)

Parameter	Symbol	Conditions	OP200E			OP200G			Unit
			Min	Typ	Max	Min	Typ	Max	
Input Offset Voltage	V_{OS}			35	100		110	300	μV
Average Input Offset Voltage Drift	TCV_{OS}			0.2	0.5		0.6	2.0	$\mu\text{V}/^\circ\text{C}$
Input Offset Current	I_{OS}	$V_{CM} = 0\text{ V}$		0.08	2.5		0.1	6.0	nA
Input Bias Current	I_B	$V_{CM} = 0\text{ V}$		0.3	5.0		0.5	10.0	nA
Large-Signal Voltage Gain	A_{VO}	$V_O = \pm 10\text{ V}$ $R_L = 10\text{ k}\Omega$ $R_L = 2\text{ k}\Omega$	3000 1500	10000 3200		2000 1000	5000 2500		V/mV V/mV
Input Voltage Range*	IVR		± 12	± 12.5		± 12	± 12.5		V
Common-Mode Rejection	CMR	$V_{CM} = \pm 12\text{ V}$	115	130		105	130		dB
Power Supply Rejection Ratio	PSRR	$V_S = \pm 3\text{ V}$ to $\pm 18\text{ V}$		0.15	3.2		0.3	10.0	$\mu\text{V}/\text{V}$
Output Voltage Swing	V_O	$R_L = 10\text{ k}\Omega$ $R_L = 2\text{ k}\Omega$	± 12 ± 11	± 12.4 ± 12		± 12 ± 11	± 12.4 ± 12.2		V V
Supply Current Per Amplifier	I_{SY}	No Load		600	775		600	775	μA
Capacitive Load Stability		$A_V = 1$ No Oscillations		10 10			10 10		nF nF

*Guaranteed by CMR test.

Specifications subject to change without notice.

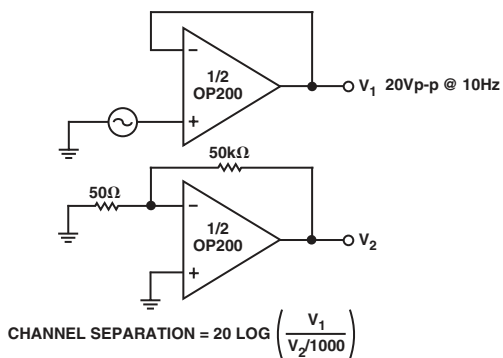

Figure 2. Channel Separation Test Circuit

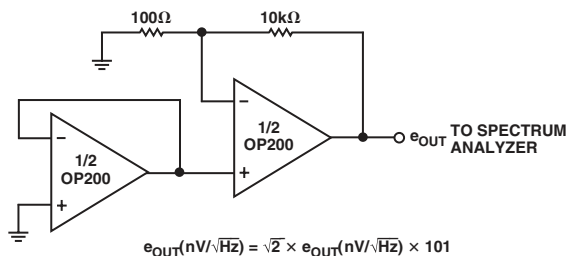

Figure 3. Noise Test Schematic

ABSOLUTE MAXIMUM RATINGS¹

Supply Voltage	±20 V
Differential Input Voltage	±30 V
Input Voltage	Supply Voltage
Output Short-Circuit Duration	Continuous
Storage Temperature Range	
P, S, Z-Package	-65°C to +150°C
Lead Temperature Range (Soldering, 60 sec)	300°C
Junction Temperature (T _J)	-65°C to +150°C
Operating Temperature Range	
OP200A	-55°C to +125°C
OP200E	-40°C to +85°C
OP200G	-40°C to +85°C

Package Type	θ _{JA} ²	θ _{JC}	Unit
8-Lead Cerdip (Z)	148	16	°C/W
8-Lead Plastic DIP (P)	96	37	°C/W
16-Lead SOIC (S)	92	27	°C/W

NOTES

¹Absolute maximum ratings apply to both DICE and packaged parts, unless otherwise noted.

²θ_{JA} is specified for worst-case mounting conditions, i.e., θ_{JA} is specified for device in socket for Cerdip and PDIP packages; θ_{JA} is specified for device soldered to printed circuit board for SOIC package.

CAUTION

ESD (electrostatic discharge) sensitive device. Electrostatic charges as high as 4000 V readily accumulate on the human body and test equipment and can discharge without detection. Although the OP200 features proprietary ESD protection circuitry, permanent damage may occur on devices subjected to high energy electrostatic discharges. Therefore, proper ESD precautions are recommended to avoid performance degradation or loss of functionality.

ORDERING GUIDE

T _A = 25°C V _{OS} Max (μV)	Package		Operating Temperature Range
	CERDIP 8-Lead	Plastic	
75	OP200AZ		MIL
75	OP200EZ		XIND
200		OP200GP	XIND
200		OP200GS	XIND
200		OP200GS-REEL	XIND

For military processed devices, please refer to the Standard Microcircuit Drawing (SMD) available at www.dsccl.dla.mil/programs/milspec/default.asp

SMD Part Number	ADI Equivalent
5962-8859301M2A	OP200ARCMDA
5962-8859301MPA	OP200AZMDA



OP200—Typical Performance Characteristics

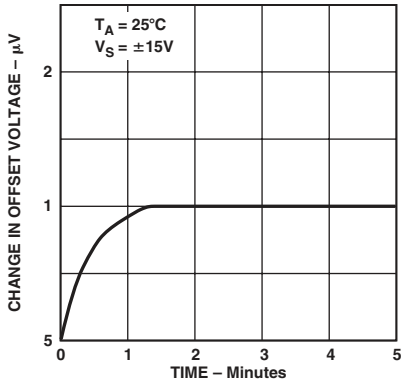

TPC 1. Warm-Up Drift

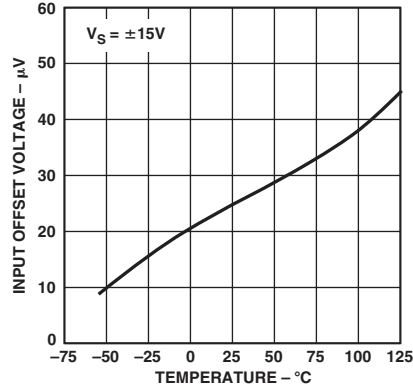

TPC 2. Input Offset Voltage vs. Temperature

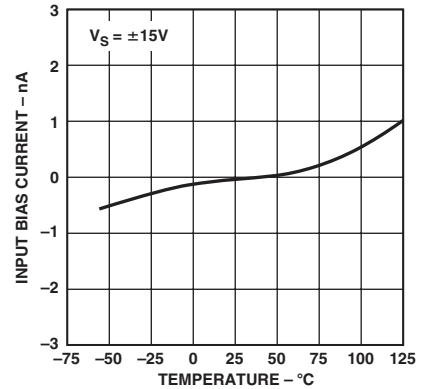

TPC 3. Input Bias Current vs. Temperature

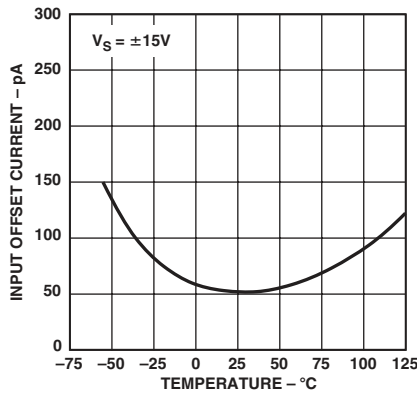

TPC 4. Input Offset Current vs. Temperature

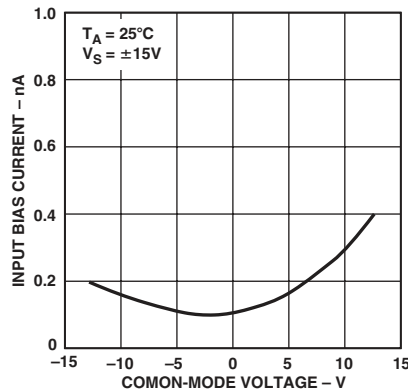

TPC 5. Input Bias Current vs. Common-Mode Voltage

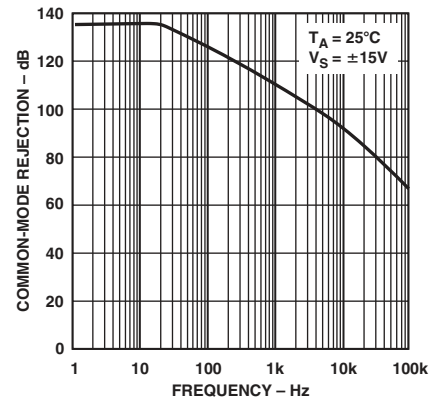

TPC 6. Common-Mode Rejection vs. Frequency

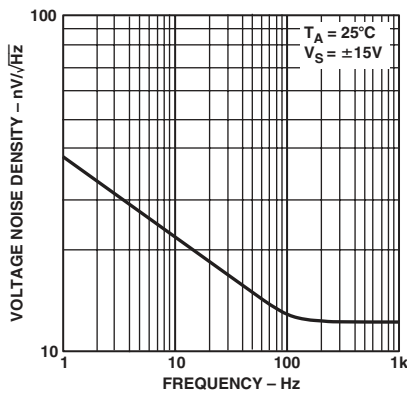

TPC 7. Voltage Noise Density vs. Frequency

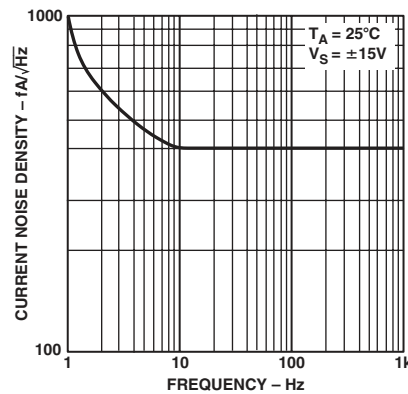

TPC 8. Current Noise Density vs. Frequency

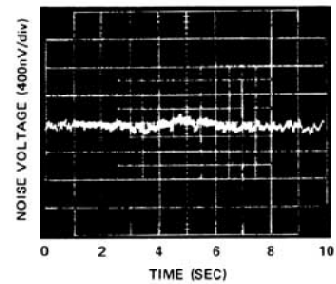

TPC 9. 0.1 to 10 Hz Noise

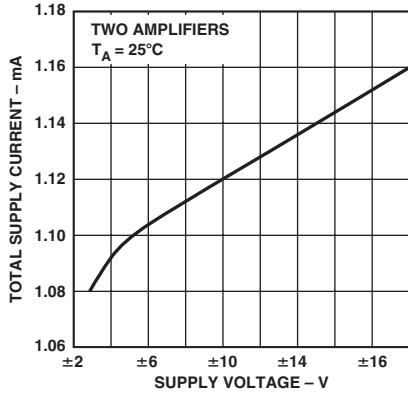

TPC 10. Total Supply Current vs. Supply Voltage

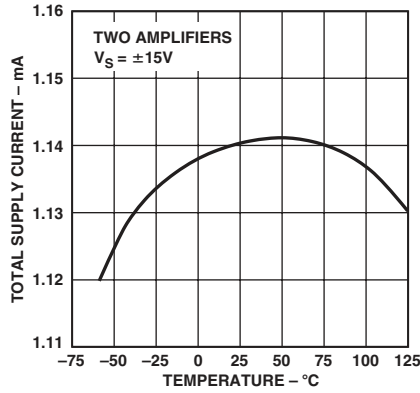

TPC 11. Total Supply Current vs. Temperature

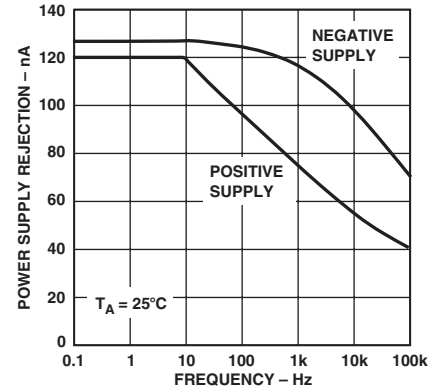

TPC 12. Power Supply Rejection vs. Frequency

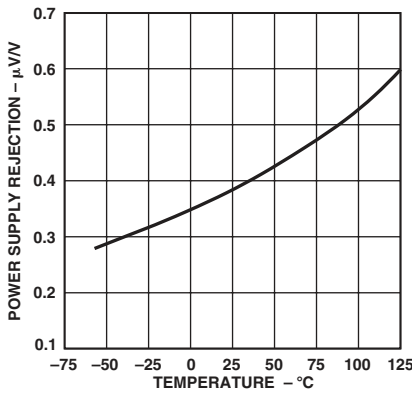

TPC 13. Power Supply Rejection vs. Temperature

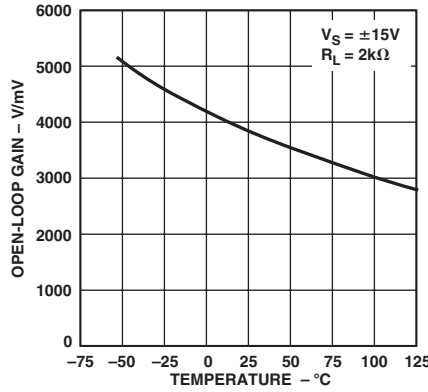

TPC 14. Open-Loop Gain vs. Temperature

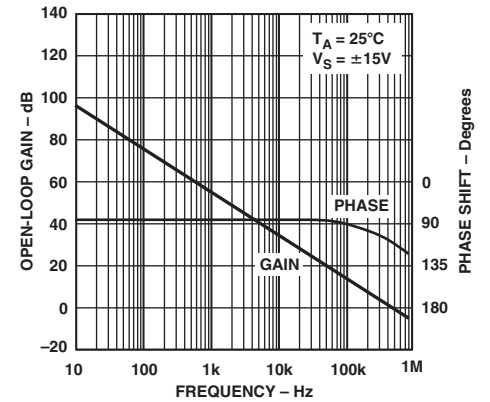

TPC 15. Open-Loop Gain and Phase Shift vs. Frequency

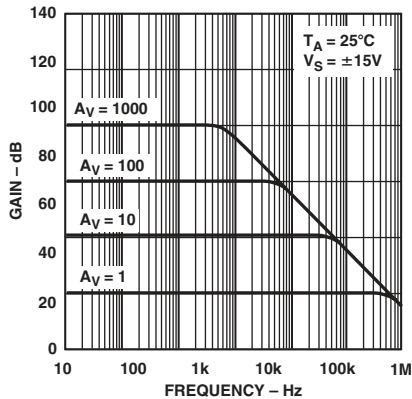

TPC 16. Closed-Loop Gain vs. Frequency

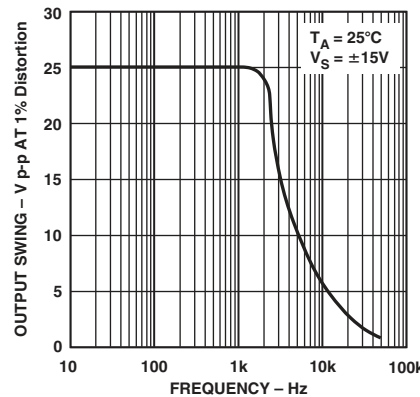

TPC 17. Maximum Output Swing vs. Frequency

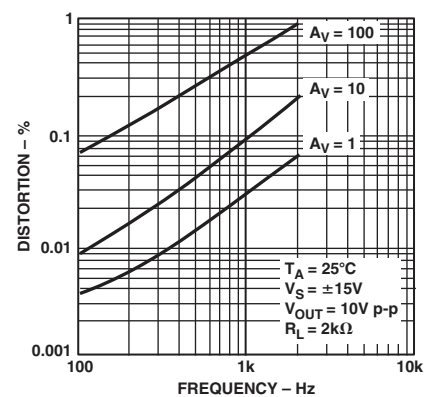

TPC 18. Total Harmonic Distortion vs. Frequency

OP200

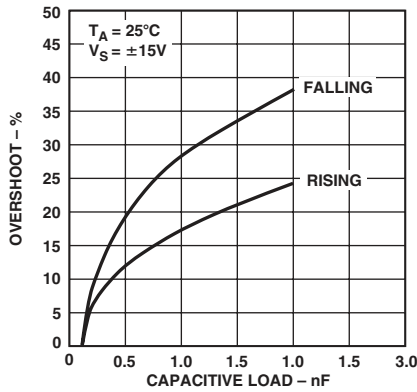

TPC 19. Overshoot vs. Capacitive Load

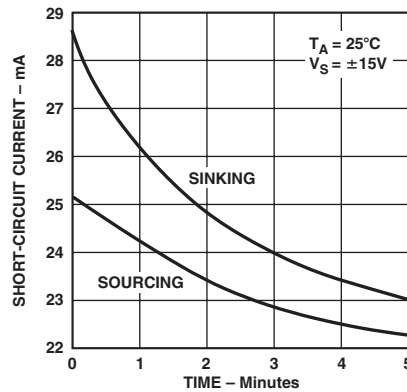

TPC 20. Short-Circuit Current vs. Time

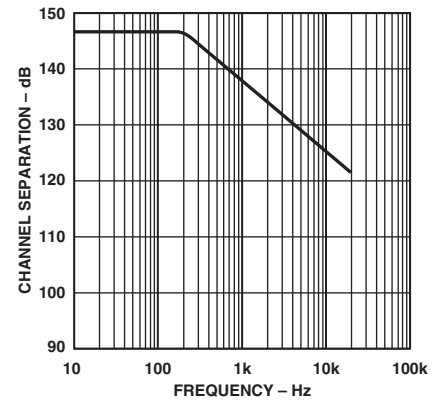

TPC 21. Channel Separation vs. Frequency

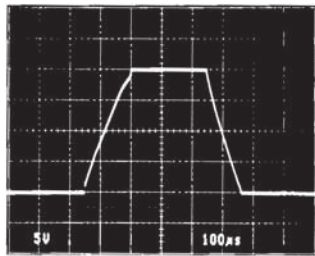

TPC 22. Large Signal Transient Response

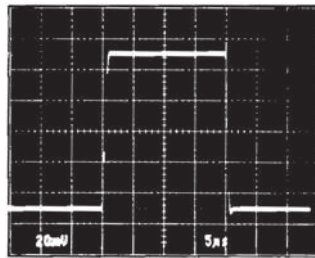

TPC 23. Small Signal Transient Response

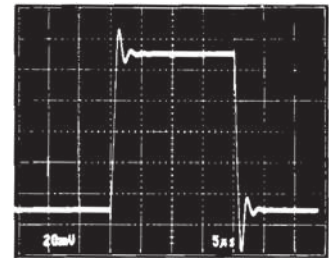

TPC 24. Small Signal Transient Response $C_{LOAD} = 1 \text{ nF}$

APPLICATIONS INFORMATION

The OP200 is inherently stable at all gains and is capable of driving large capacitive loads without oscillating. Nonetheless, good supply decoupling is highly recommended. Proper supply decoupling reduces problems caused by supply line noise and improves the capacitive load driving capability of the OP200.

APPLICATIONS

Dual Low-Power Instrumentation Amplifier

A dual instrumentation amplifier that consumes less than 33 mW of power per channel is shown in Figure 4. The linearity of the instrumentation amplifier exceeds 16 bits in gains of 5 to 200 and is better than 14 bits in gains from 200 to 1000. CMRR is above 115 dB (gain = 1000). Offset voltage drift is typically $0.2 \mu\text{V}/^\circ\text{C}$ over the military temperature range, which is comparable to the best monolithic instrumentation amplifiers. The bandwidth of the low power instrumentation amplifier is a function of gain and is shown below:

Gain	Bandwidth
5	150 kHz
10	67 kHz
100	7.5 kHz
1000	500 Hz

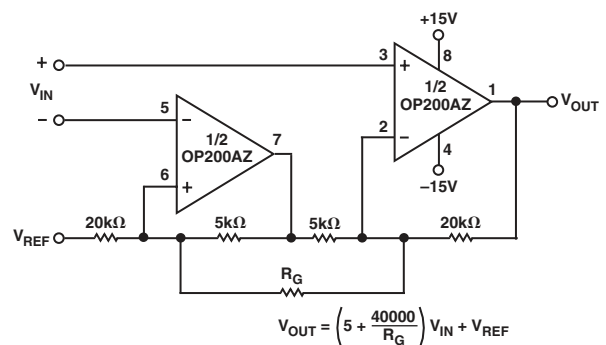

Figure 4. Dual Low Power Instrumentation Amplifier
The output signal is specified with respect to the reference input, which is normally connected to analog ground. The reference input can be used to offset the output from -10 V to $+10 \text{ V}$ if required.

Precision Absolute Value Amplifier

The circuit in Figure 5 is a precision absolute value amplifier with an input impedance of 10 MΩ. The high gain and low TCV_{OS} of the OP200 ensure accurate operation with microvolt input signals. In this circuit, the input always appears as a common-mode signal to the op amps. The CMR of the OP200 exceeds 120 dB, yielding an error of less than 2 ppm.

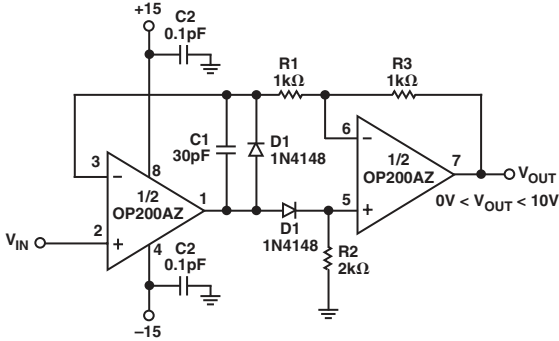

Figure 5. Precision Absolute Value Amplifier

Precision Current Pump

Maximum output current of the precision current pump shown in Figure 6 is ±10 mA. Voltage compliance is ±10 V with ±15 V supplies. Output impedance of the current transmitter exceeds 3 MΩ with linearity better than 16 bits.

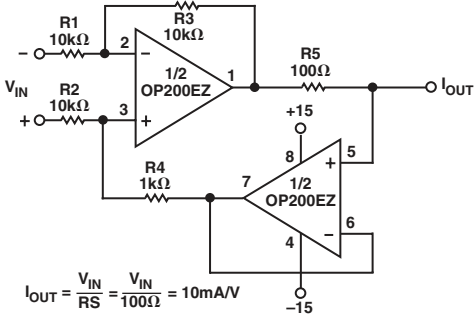

Figure 6. Precision Current Pump

Dual 12-Bit Voltage Output DAC

The dual output DAC shown in Figure 7 is capable of providing untrimmed 12-bit accurate operation over the entire military temperature range. Offset voltage, bias current, and gain errors of the OP200 contribute less than 1/10 of an LSB error at 12 bits over the military temperature range.

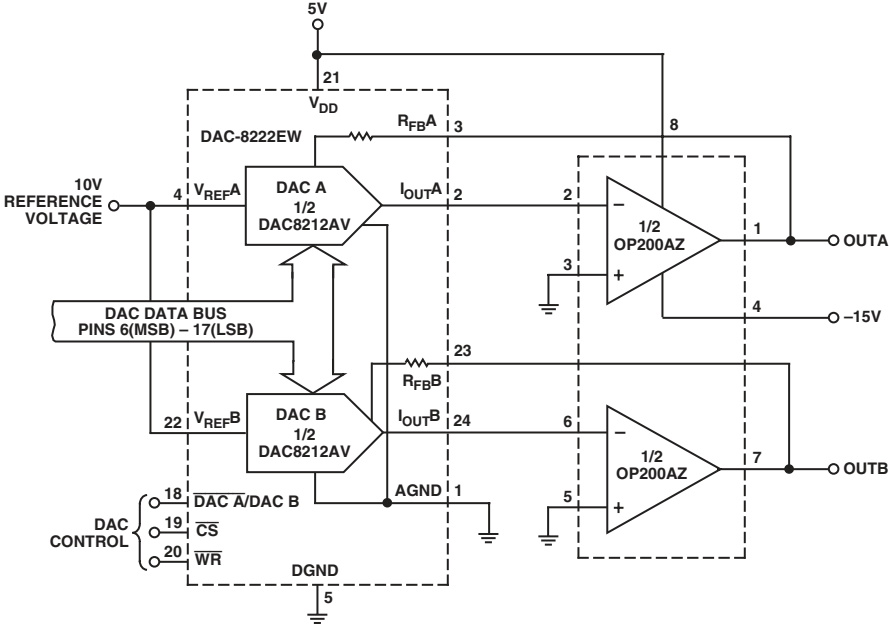

Figure 7. Dual 12-Bit Voltage Output DAC

OP200

Dual Precision Voltage Reference

A dual OP200 and a REF43, a 2.5 V reference, can be used to build a ± 2.5 V precision voltage reference. Maximum output current from each reference is ± 10 mA with load regulation under $25 \mu\text{V}/\text{mA}$. Line regulation is better than $15 \mu\text{V}/\text{V}$ and output voltage drift is under $20 \mu\text{V}/^\circ\text{C}$. Output voltage noise from 0.1 Hz to 10 Hz is typically $75 \mu\text{V}$ p-p. R1 and D1 ensure correct start-up.

Programmable High Resolution Window Comparator

The programmable window comparator shown in Figure 9 is easily capable of 12-bit accuracy over the full military temperature range. A dual CMOS 12-bit DAC, the DAC8212, is used in the voltage switching mode to set the upper and lower thresholds (DAC A and DAC B, respectively).

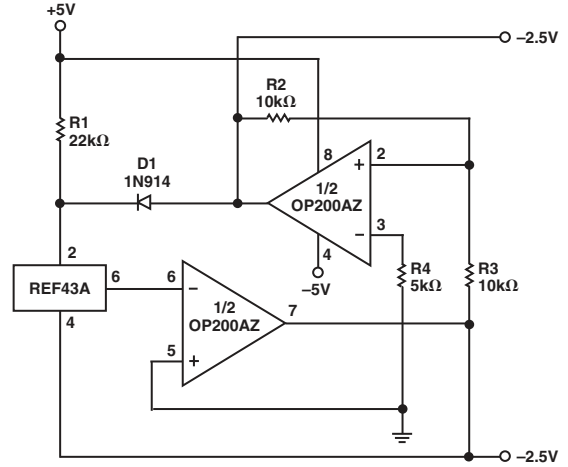

Figure 8. Dual Precision Voltage Reference

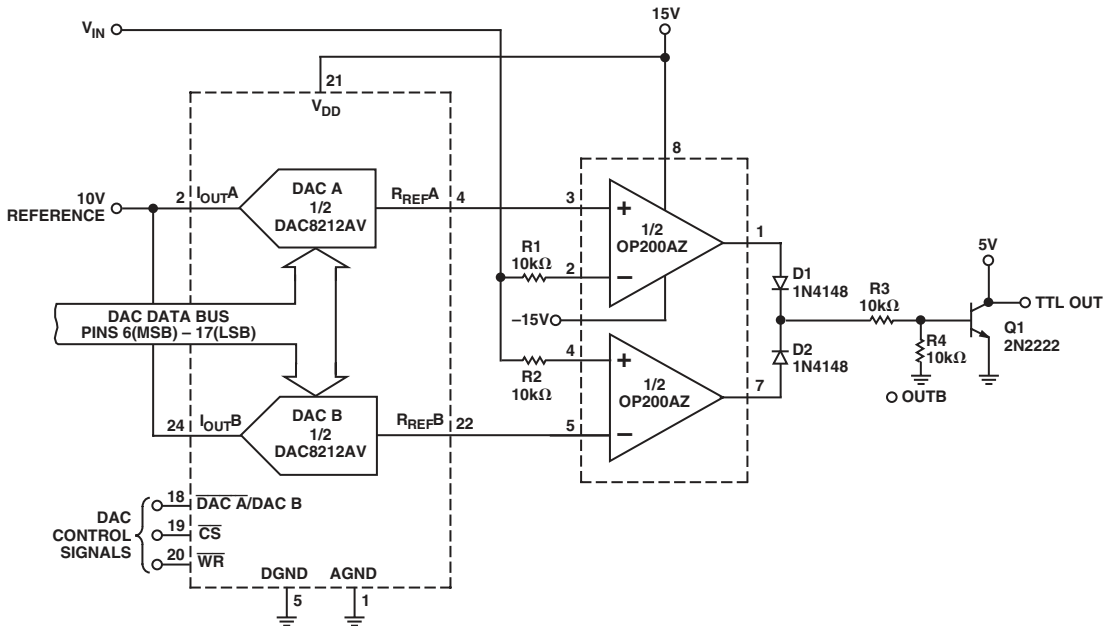
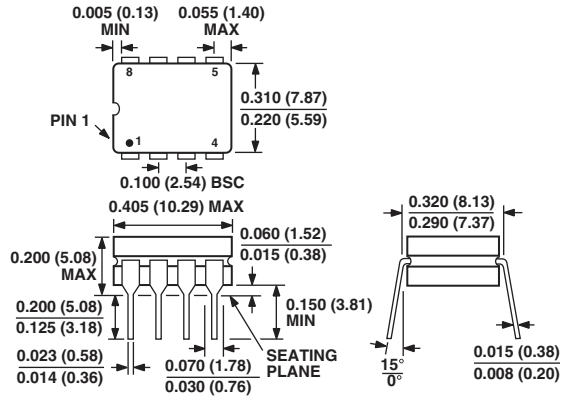

Figure 9. Programmable High Resolution Window Comparator

OUTLINE DIMENSIONS

8-Lead Ceramic Dual In-Line Package [CERDIP]
(Q-8)
Z-Suffix

Dimensions shown in inches and (millimeters)



CONTROLLING DIMENSIONS ARE IN INCHES; MILLIMETERS DIMENSIONS (IN PARENTHESES) ARE ROUNDED-OFF INCH EQUIVALENTS FOR REFERENCE ONLY AND ARE NOT APPROPRIATE FOR USE IN DESIGN

8-Lead Plastic Dual In-Line Package [PDIP]
(N-8)
P-Suffix

Dimensions shown in inches and (millimeters)

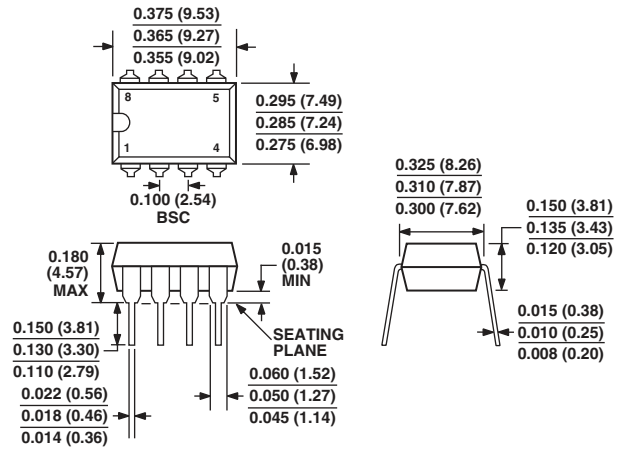

COMPLIANT TO JEDEC STANDARDS MO-095AA
CONTROLLING DIMENSIONS ARE IN INCHES; MILLIMETER DIMENSIONS (IN PARENTHESES) ARE ROUNDED-OFF INCH EQUIVALENTS FOR REFERENCE ONLY AND ARE NOT APPROPRIATE FOR USE IN DESIGN

16-Lead Standard Small Outline Package [SOIC]
Wide Body
(RW-16)
S-Suffix

Dimensions shown in millimeters and (inches)

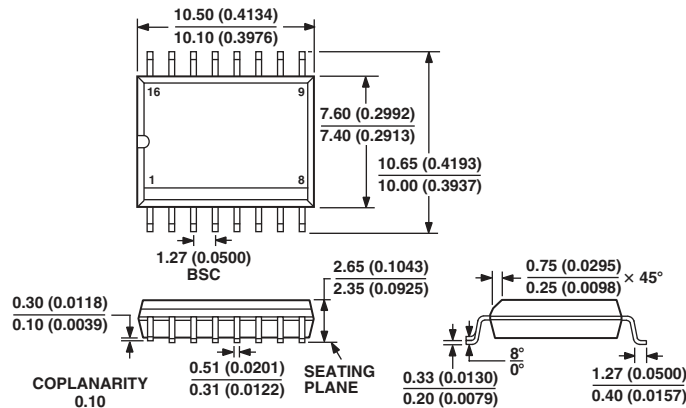

COMPLIANT TO JEDEC STANDARDS MS-013AA
CONTROLLING DIMENSIONS ARE IN MILLIMETERS; INCH DIMENSIONS (IN PARENTHESES) ARE ROUNDED-OFF MILLIMETER EQUIVALENTS FOR REFERENCE ONLY AND ARE NOT APPROPRIATE FOR USE IN DESIGN

OP200

Revision History

Location	Page
2/04—Data Sheet changed from REV. A to REV. B.	
OP200F deleted	Universal
Changes to ORDERING GUIDE	5
Changes to Figure 4	8
Updated OUTLINE DIMENSIONS	11
4/02—Data Sheet changed from REV. 0 to REV. A.	
Edits to FEATURES	1
Edits to GENERAL DESCRIPTION	1
Edits to ORDERING INFORMATION	1
Edits to PIN CONNECTIONS	1
Edits to ABSOLUTE MAXIMUM RATINGS	2
Edits to PACKAGE TYPE	2

C00322-0-2/04(B)