

THIS DRAWING IS UNPUBLISHED. RELEASED FOR PUBLICATION 20
 © COPYRIGHT 20 BY - ALL RIGHTS RESERVED.

REVISIONS							
LOC	DIST	P	LTR	DESCRIPTION	DATE	DWN	APVD
AF	50		B	REVISED PER ECR-16-008945	21NOV2016	BW	RS

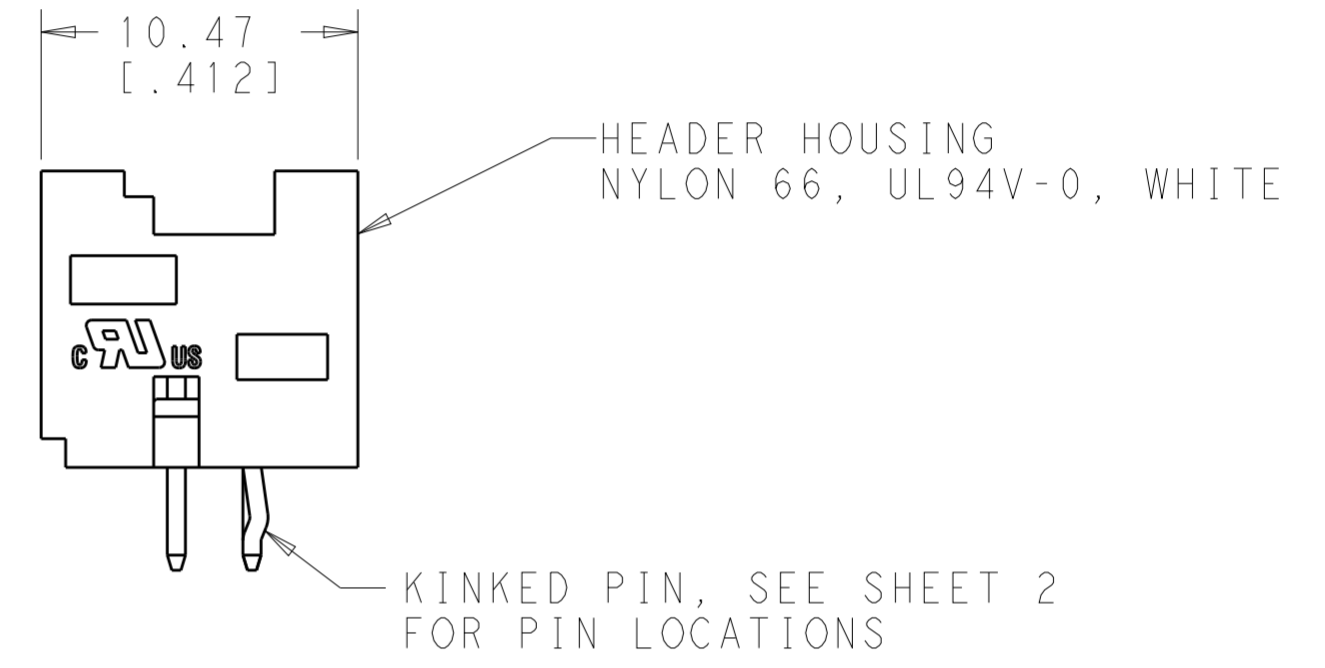

PIN, BRASS WITH
TIN PLATING OVER NICKEL

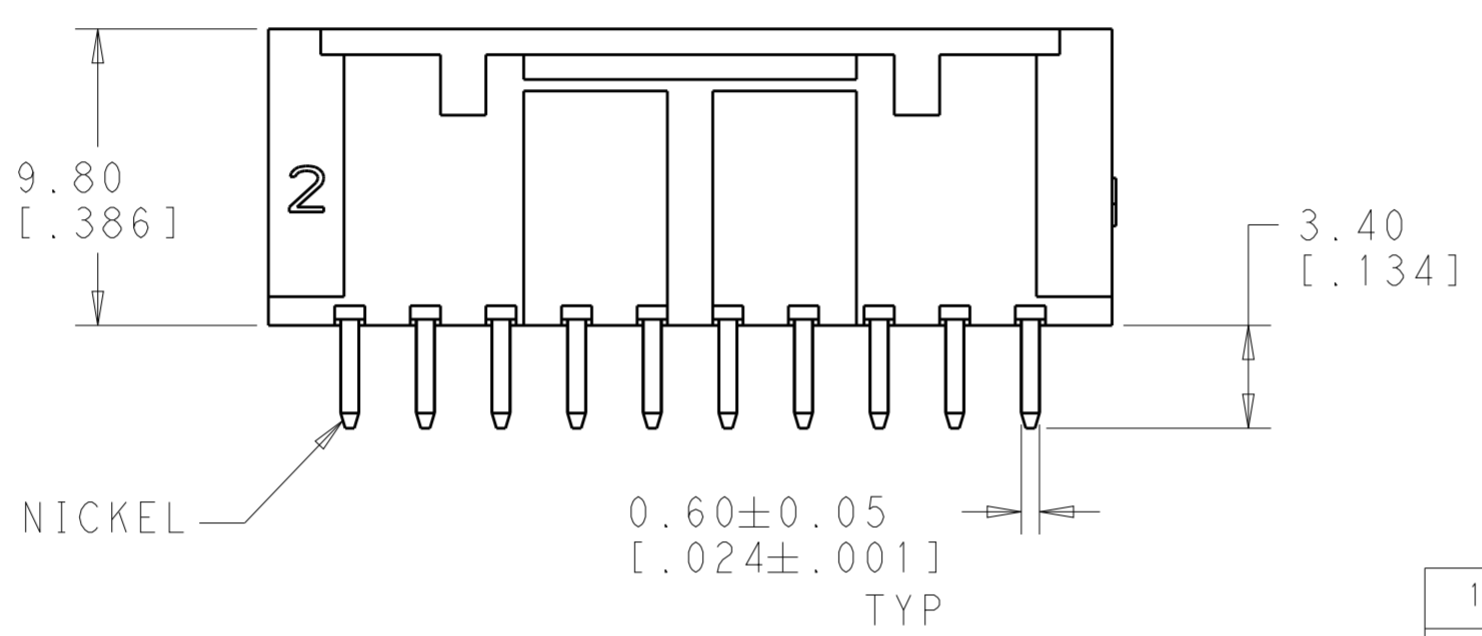
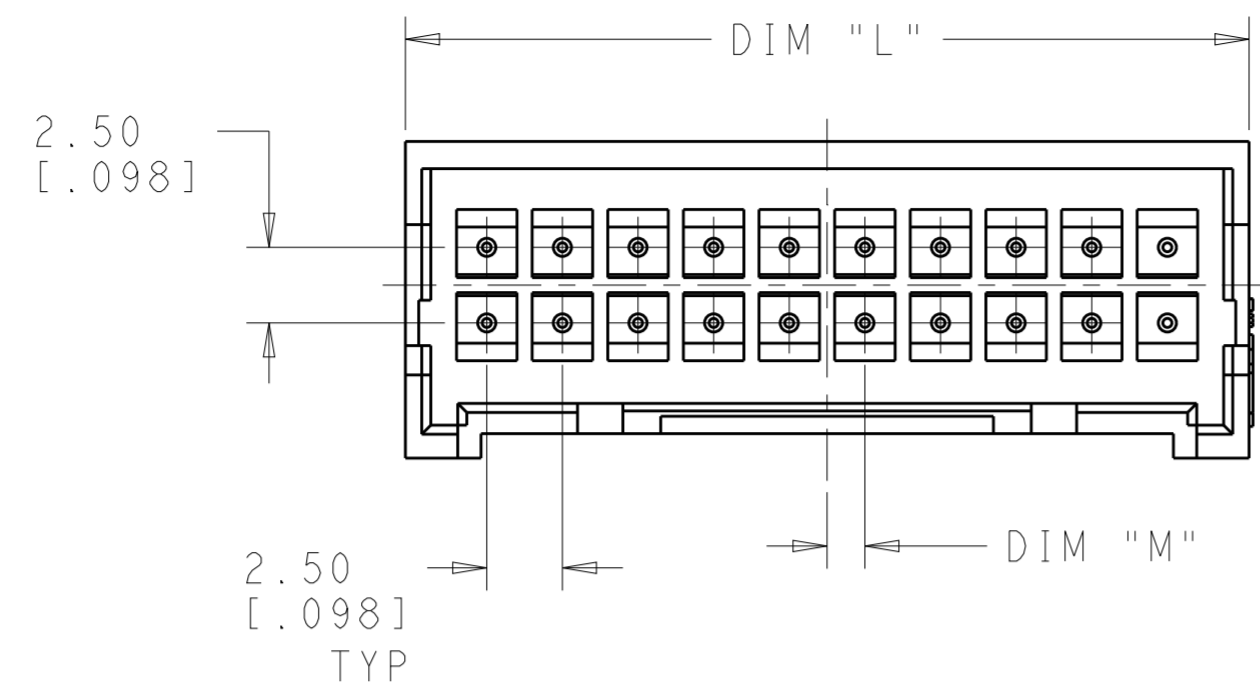
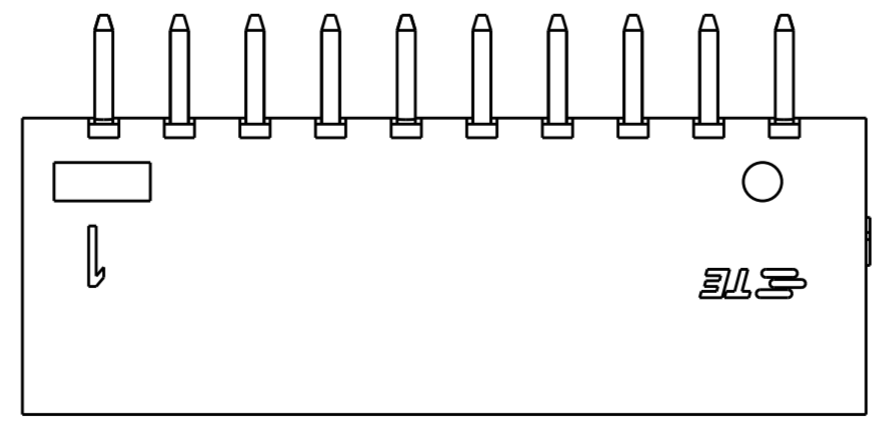
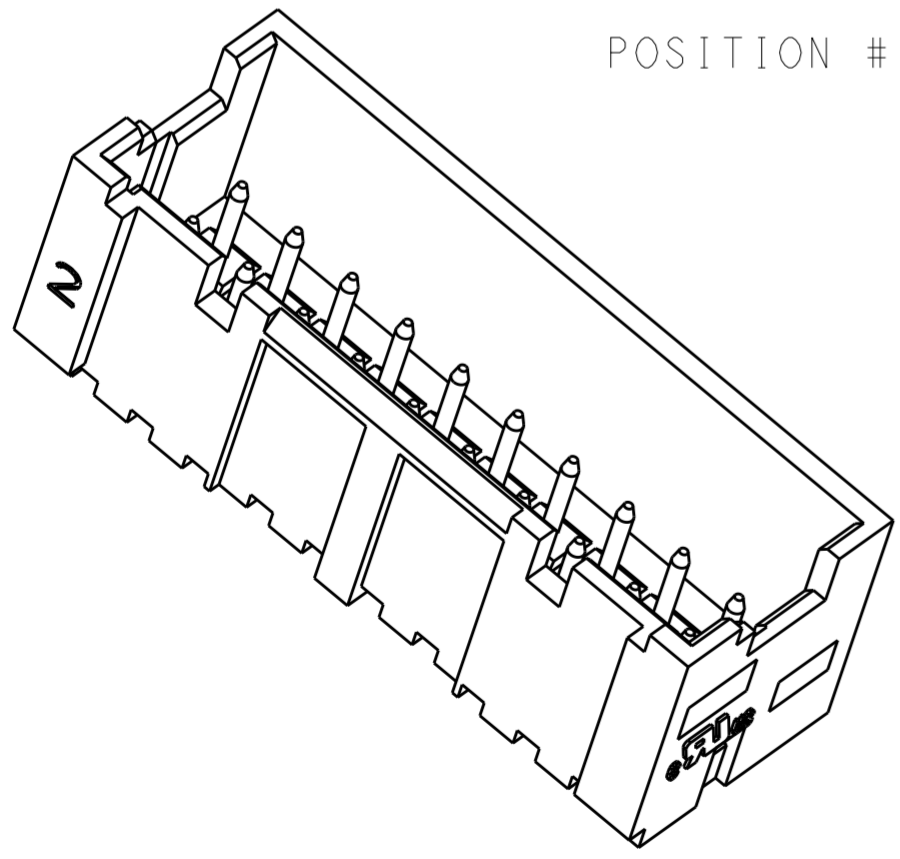
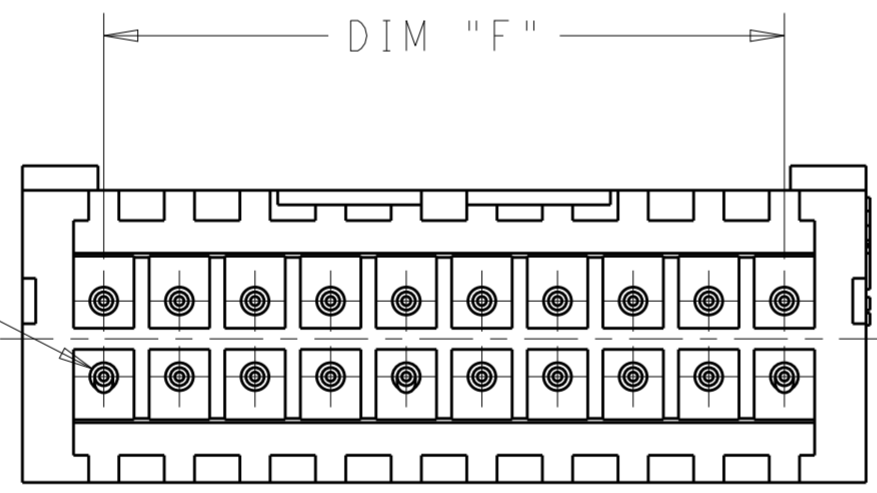

1.25 [.049]	2	47.50 [1.870]	52.89 [2.083]	40	4-1969582-0
0.00	2	45.00 [1.772]	50.39 [1.985]	38	3-1969582-8
1.25 [.049]	2	42.50 [1.673]	47.89 [1.886]	36	3-1969582-6
0.00	2	40.00 [1.575]	45.39 [1.788]	34	3-1969582-4
1.25 [.049]	2	37.50 [1.477]	42.89 [1.689]	32	3-1969582-2
0.00	2	35.00 [1.378]	40.39 [1.591]	30	3-1969582-0
1.25 [.049]	2	32.50 [1.280]	37.89 [1.492]	28	2-1969582-8
0.00	2	30.00 [1.181]	35.39 [1.394]	26	2-1969582-6
1.25 [.049]	2	27.50 [1.083]	32.89 [1.295]	24	2-1969582-4
0.00	2	25.00 [.984]	30.39 [1.197]	22	2-1969582-2
1.25 [.049]	2	22.50 [.886]	27.89 [1.098]	20	2-1969582-0
0.00	2	20.00 [.787]	25.39 [1.000]	18	1-1969582-8
1.25 [.049]	1	17.50 [.689]	22.89 [.901]	16	1-1969582-6
0.00	1	15.00 [.590]	20.39 [.803]	14	1-1969582-4
1.25 [.049]	1	12.50 [.492]	17.89 [.704]	12	1-1969582-2
0.00	1	10.00 [.394]	15.39 [.606]	10	1-1969582-0
1.25 [.049]	1	7.50 [.295]	12.89 [.507]	8	1969582-8
DIM "M"	NO. OF LATCH CUT-OUTS	DIM "F"	DIM "L"	NO. OF POSITIONS	PART NO.

THIS DRAWING IS A CONTROLLED DOCUMENT.

DWN: JR RUTH 06NOV12
 CHK: KURT RANDOLPH 06NOV12
 APVD: SAM MACE 06NOV12

STE TE Connectivity

NAME: ASSEMBLY, PIN HEADER, EP 2.5, DUAL ROW

PRODUCT SPEC: 108-2418
 APPLICATION SPEC: 114-13315

SIZE: A2 CAGE CODE: 00779 DRAWING NO: C-1969582 RESTRICTED TO: -

MATERIAL: SEE NOTES TOLERANCES UNLESS OTHERWISE SPECIFIED: SEE NOTES

Customer Drawing SCALE: 4:1 SHEET 1 OF 2 REV B

THIS DRAWING IS UNPUBLISHED. RELEASED FOR PUBLICATION 20
 © COPYRIGHT 20 BY - ALL RIGHTS RESERVED.

LOC	DIST	REVISIONS			
P	LTR	DESCRIPTION	DATE	DWN	APVD
AF	50	-	SEE SHEET 1	-	-

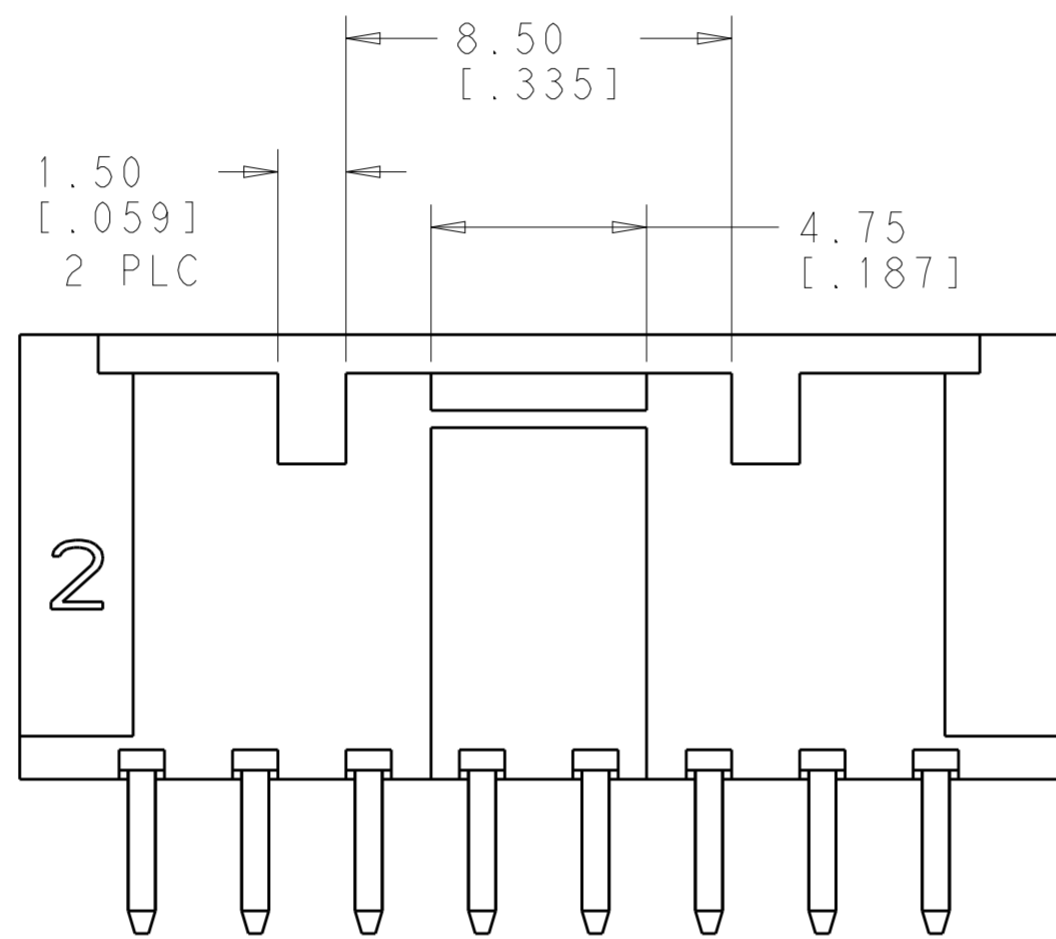
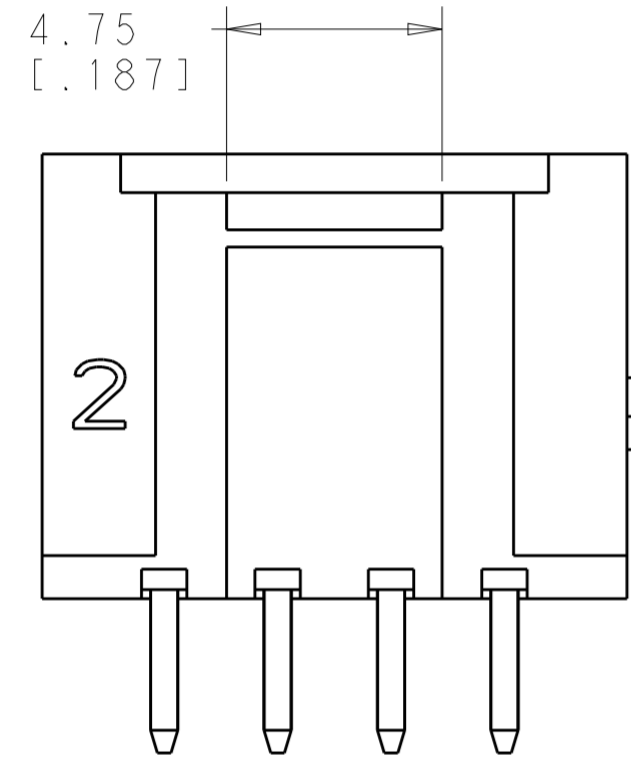
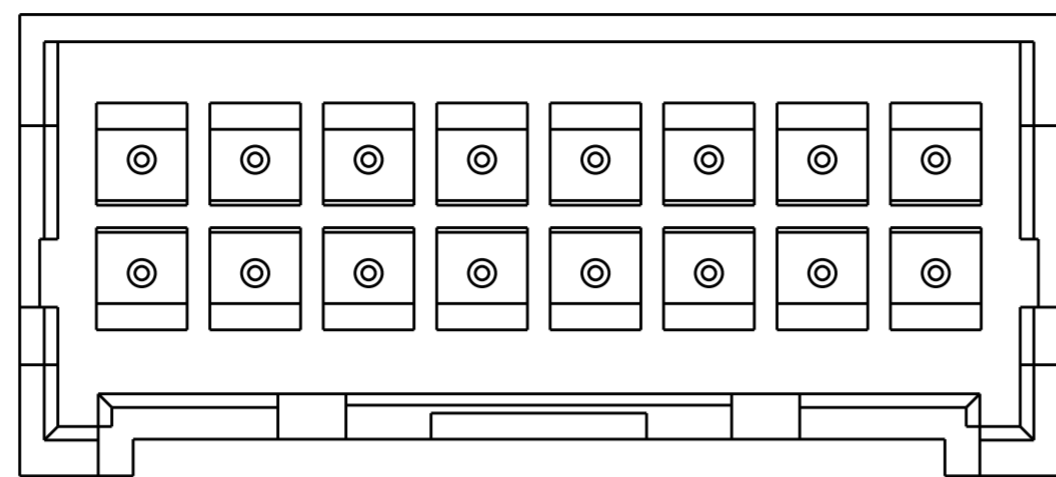
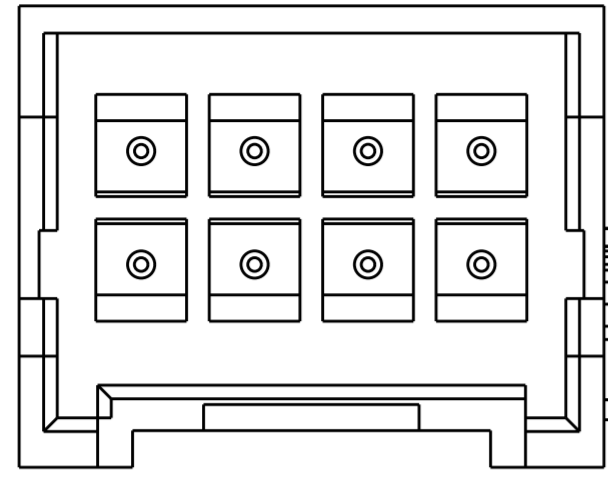

SINGLE LATCH DETAIL
 1969582-8 SHOWN HERE
 THESE DIM'S ARE FOR THE
 1969582-8 AND 1-1969582-0

SINGLE LATCH DETAIL
 1-1969582-6 SHOWN ON HERE
 THESE DIM'S ARE FOR THE
 1-1969582-2 THRU -16

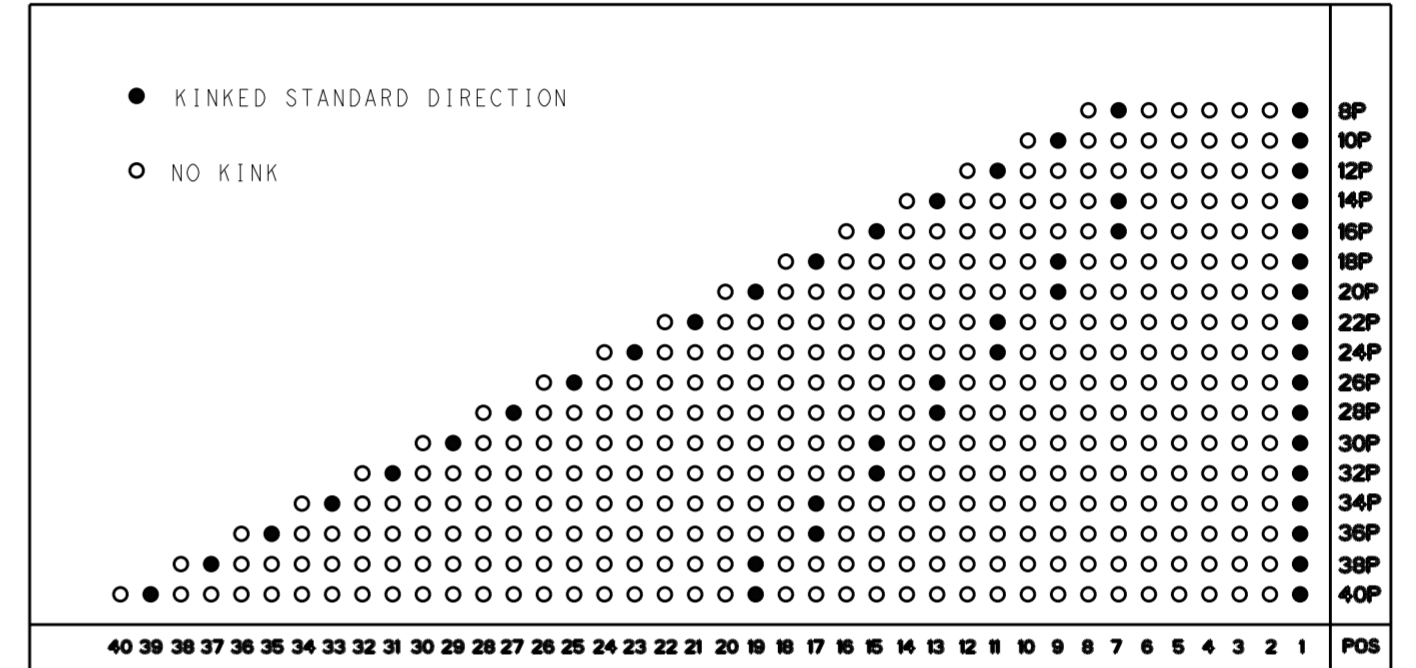

KINKED PIN CHART

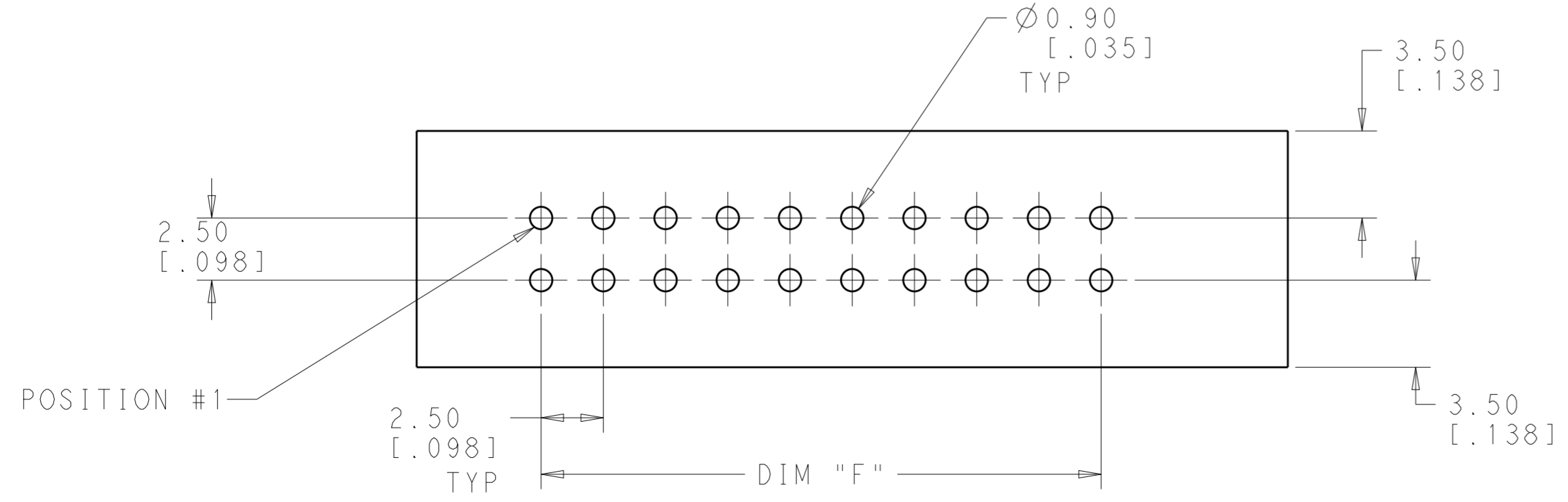

RECOMMENDED PCB LAYOUT

THIS DRAWING IS A CONTROLLED DOCUMENT.		DWN JR RUTH 06NOV12	TE Connectivity			
DIMENSIONS: mm[INCHES]		CHK KURT RANDOLPH 06NOV12				
TOLERANCES UNLESS OTHERWISE SPECIFIED:		APVD SAM MACE 06NOV12				
0 PLC ± 1 PLC ± 2 PLC ±0.25 [.010] 3 PLC ± 4 PLC ± ANGLES ± FINISH ±		NAME ASSEMBLY, PIN HEADER, EP 2.5, DUAL ROW	SIZE	CAGE CODE	DRAWING NO	RESTRICTED TO
SEE NOTES		PRODUCT SPEC 108-2418	A2	00779	C-1969582	-
MATERIAL		APPLICATION SPEC 114-13315	SCALE 4:1		SHEET 2 OF 2	REV B
Customer Drawing		WEIGHT -				