

7" Touchscreen HMI



- Security, Datalogging
- Trends, Plots
- Pass through mode
- Macros
- Serial & Ethernet

EasyAccess2.0

System	CPU	32-bit RISC Cortex-A8, 600 MHz
	Memory (RAM)	128 MB
	Memory (Flash)	128 MB
	RTC	Built-in
I/O Ports	Serial	1 x DE9P COM1: RS-232, COM2: RS-485 2 or 4 wire
	LAN	1 x 10/100 Base-T RJ-45
	CANbus	N/A
	USB Host	1 x USB 2.0
	USB Client	N/A
	Audio	N/A
	Video	N/A
	Wi-Fi	N/A
	HDMI®	N/A
	SD Card Slot	N/A
	Display	Display Type
Size (W x H)		5.98 x 3.58 inches [152 x 91 mm]
Resolution (pixels)		800 x 480
Max. Colors		16 M
Luminance (cd/m²)		300
Viewing Angle (H°/V°)		140/120
Contrast Ratio		500:1
Touch Screen	Type	4-wire resistive touch
	Active Area Accuracy	Length (X) ±2%, width (Y) ±2%
Electrical	Input Voltage	10.5 ~ 28.0 VDC
	Input Current	500 mA @ 24 VDC
	Input Power	12 W
	Power Isolation	Built-in
	Isolation Resistance	Exceed 50 MΩ at 500 VDC
Mechanical	Enclosure	Plastic, charcoal grey
	PCB Coating	N/A
	Dimensions (W x H x D)	7.89 x 5.77 x 1.34 inches [200.4 x 146.5 x 34 mm]
	Net Weight	Approx. 1.15 lbs. [0.52 kg]
Environmental	Mounting	Panel mounting
	Operating Temperature	32° ~ 122°F (0° ~ 50°C)
	Storage Temperature	-4° ~ 140°F (-20° ~ 60°C)
	Relative Humidity	10% ~ 90% (non-condensing)
	Vibration Endurance	10 to 25 Hz (X, Y, Z direction, 2G, 30 minutes)
	Ratings	NEMA 4, IP65 compliant front panel
Software	Certifications	CE, RoHS
		EBPro (v6.00.01.174 or later), Modbus, VNC Server
Notes	Specifications subject to change without notice	

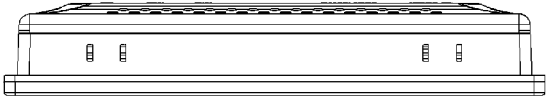

Top View

Dimensions are in inches [mm]

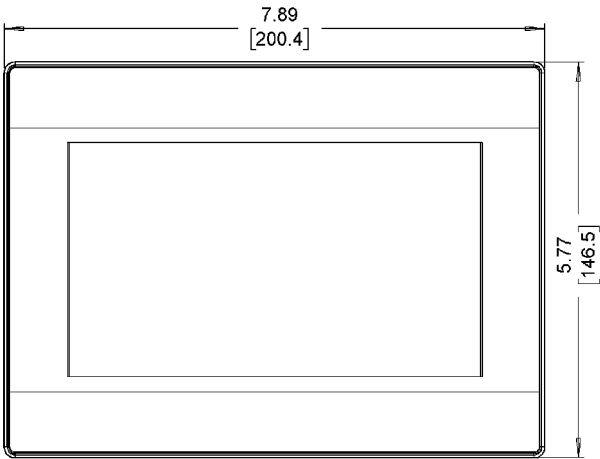

Front View

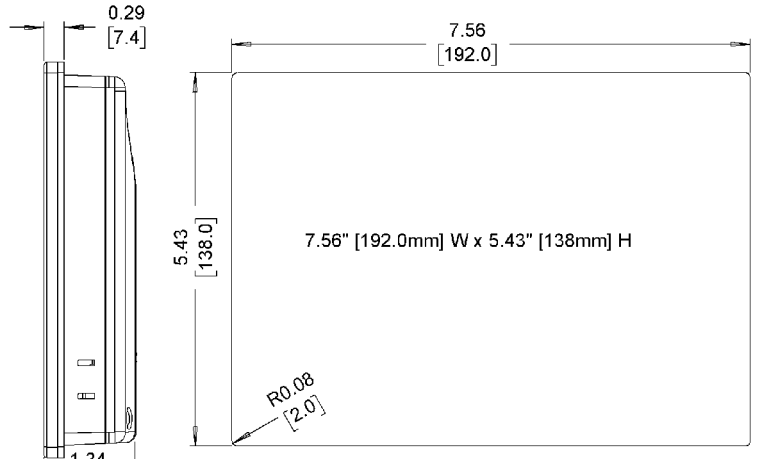

Side View

Cutout Dimensions

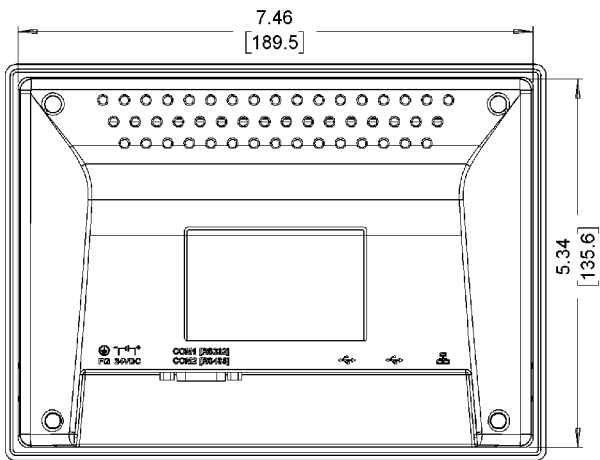

Rear View

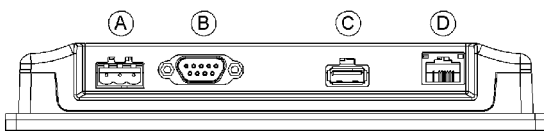

Bottom View

- A Power Connector
- B COM Port DE9P
- C USB 2.0 Host Port
- D Ethernet Port